

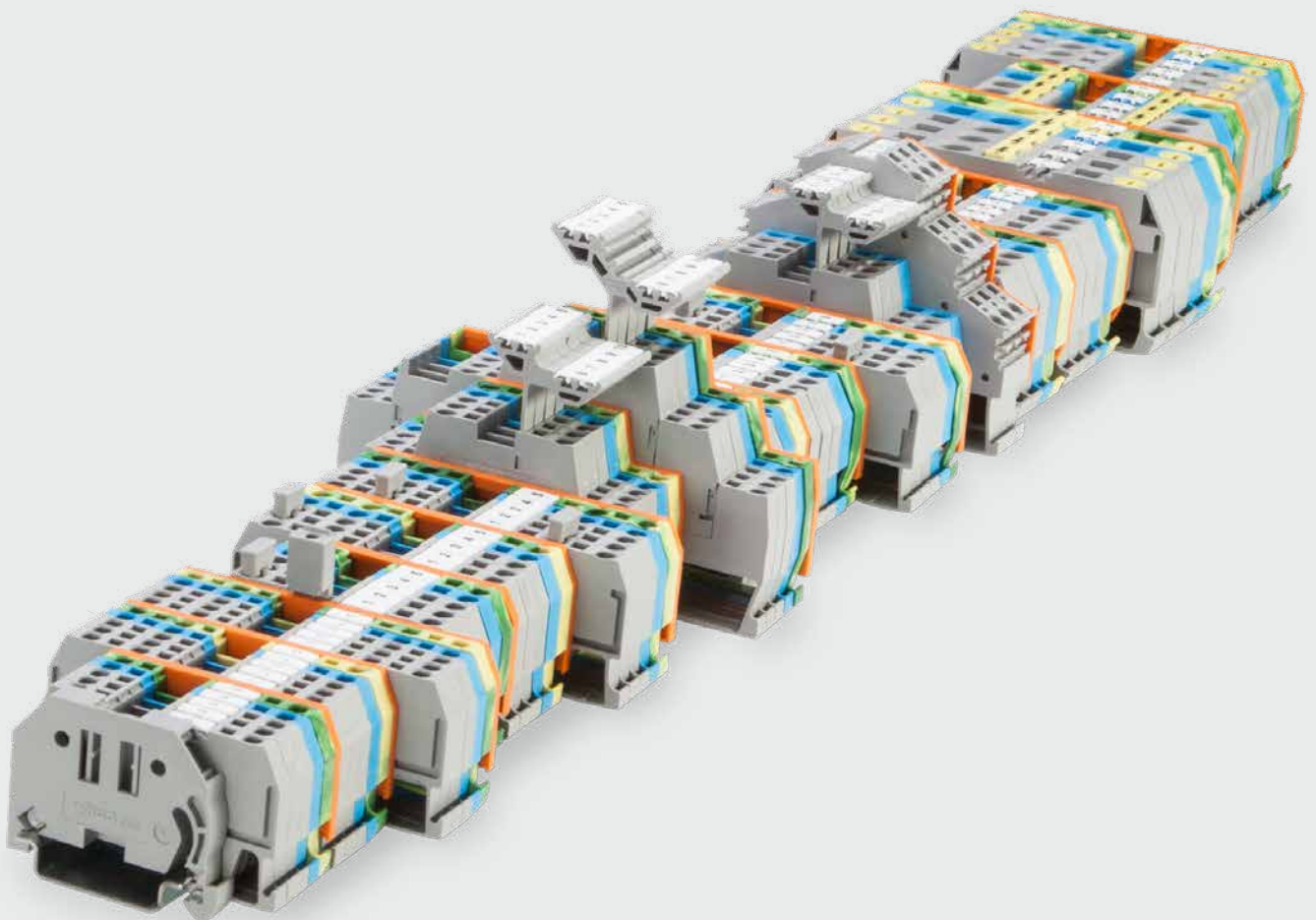

# WAGO Rail-Mount Terminal Blocks Classic

Edition 2025/1



# WAGO Full Line Catalogs



## WAGO Installation Connectors

- Splicing Connectors with Levers
- Inline Splicing Connectors with Levers
- Lighting Connectors
- PUSH WIRE® Splicing Connectors
- PUSH WIRE® Inline Splicing Connectors
- Luminaire Disconnect Connectors
- Gelboxes for Splicing Connectors
- Junction Box
- Cable Repair Set
- Splicing Connector Sets
- Accessories and Tools



## WAGO TOPJOB® S Rail-Mount Terminal Block Systems

- Rail-Mount Terminal Blocks TOPJOB® S
- Rail-Mount Terminal Blocks with a Pluggable Connector X-COM®-SYSTEM
- Installation Rail-Mount Terminal Blocks TOPJOB® S
- Miniature Rail-Mount Terminal Blocks TOPJOB® S
- High-Current Rail-Mount Terminal Blocks
- Accessories and Tools



## WAGO Rail-Mount Terminal Blocks Classic

- Rail-Mount Terminal Blocks Classic
- Rail-Mount Terminal Blocks with a Pluggable Connector X-COM®-SYSTEM
- Patchboard Systems
- Busbar Terminal Blocks
- Rail-Mount Terminal Blocks Mini
- Modular Terminal Blocks and WAGO Terminal Strips
- Chassis-Mount Terminal Strips
- Field-Wiring Terminal Blocks



## WAGO PCB Terminal Blocks and Connectors

- PCB Terminal Blocks (THT; THR; SMD)
- *MULTI CONNECTION SYSTEM (MCS)*
- *picoMAX®; picoMAX® eCom*
- Pluggable PCB Terminal Blocks
- Feedthrough Terminal Strips
- Special Connectors
- Modulare Empty Housing
- Accessories and Tools



## WAGO Pluggable Connection System WINSTA®

- Pluggable Connectors
- Snap-In Device Connectors
- Pluggable PCB Connectors
- Distribution Connectors
- Cable Assemblies
- Flat Cable Systems
- Distribution Boxes
- Accessories and Tools



#### WAGO Automation Technology

Edition 2023/1



### WAGO Automation Technology

- Solutions & Software
- Operating & Monitoring
- Controllers, Edge Devices
- Modular I/O-SYSTEM IP20, I/O-SYSTEM IP67
- Industrial Switches
- Radio Technology
- IP67 Sensor/Actuator Boxes, IP67 Cables and Connectors



#### WAGO Interface Electronics

Edition 2023/1



### WAGO Interface Electronics

- Coupler Relays
- Solid-State Relays
- Signal Conditioners and Isolation Amplifiers
- Energy Measurement Technology
- System Wiring
- Component Modules
- Empty Housing
- Protective Devices and Protective Electronics
- Accessories and Tools



#### WAGO Power Supply Systems

Edition 2023/1



### WAGO Power Supply Systems

- Power Supplies; 1-Phase
- Power Supplies; 3-Phase
- Special Supplies
- Circuit Protection
- DC/DC Converters
- UPS-Charger and Controllers and Capacitive Buffer Modules
- Redundancy Modules
- Energy Measurement Technology
- Potential Distribution
- Accessories and Tools



#### WAGO Marking

Edition 2023/1



### WAGO Marking

- Thermal Transfer Smart Printer
- Digital Engineering – Smart Data
- Products for the Smart Printer
- Printed Products
- Plain Products
- Marker Carriers

## About This Catalog

Our digital catalogs provide several search and navigation features to help you quickly find the information you need. This page introduces the key functions of the catalog.

### Searching the Catalog

To search for specific terms within the catalog, follow these steps:

- Open the search dialog via **Edit > Find** or by clicking the **magnifying glass icon**. Alternatively, use the **Ctrl + F** keyboard shortcut.
- Enter your search term in the search field.
- Click **Next** to move to the next search result.

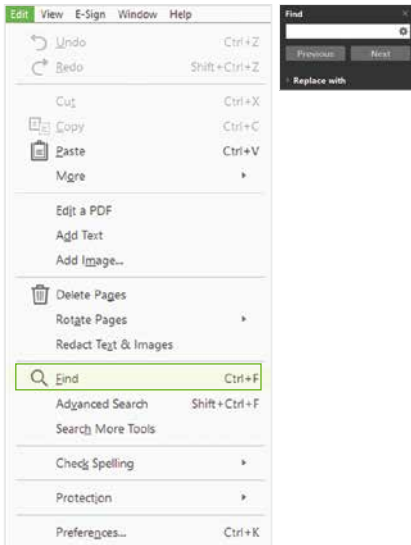

### Navigating with Bookmarks

This PDF includes bookmarks to help you quickly and easily find specific sections. With a single click, you can jump directly to a chapter in the catalog.

- Open the bookmark panel by clicking the **bookmark icon**.
- To navigate to a chapter, click the relevant bookmark in the bookmark panel. The corresponding catalog page will then be displayed.

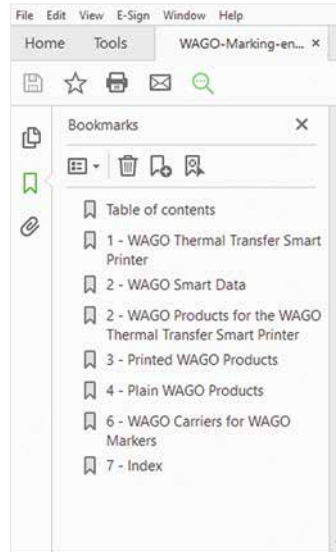

### Navigating with the Table of Contents

Our table of contents includes clickable page numbers, allowing you to jump directly to the corresponding catalog page.

WAGO Marking Accessories		Page
	WAGO Thermal Transfer Smart Printer	6
	Digital Engineering with WAGO	18
	WAGO Products for the WAGO Thermal Transfer Smart Printer	27
	Printed WAGO Products	48
	Plain WAGO Products	71
	WAGO Marker Carriers	79
	Index	87

You can also find additional clickable page numbers in the selection guides and the item number index.

### Links







To help you access additional information easily, this catalog includes links to various websites. These links may provide further product details, installation notes or quick access to important documents such as data sheets.

One example is our **item numbers**, which contain links to the corresponding product detail pages on our website. Simply click an item number to open the relevant product detail page.



You can identify links in this catalog by the presence of a URL in the link text (e.g., wago.com). In most cases, links are also underlined for easy recognition.

## WAGO Rail-Mount Terminal Blocks Classic

			Page	
	<b>WAGO Rail-Mount Terminal Blocks Classic</b> Front-Entry Wiring	CAGE CLAMP® 1,5 ... 35 mm <sup>2</sup> / 16 ... 2 AWG for DIN-35 rail	2	1
	<b>WAGO Rail-Mount Terminal Blocks with a Pluggable Connector X-COM®-SYSTEM</b> Front-Entry Wiring	CAGE CLAMP® 2,5 (4) mm <sup>2</sup> / 12 AWG for DIN-35 rail	22	2
	<b>WAGO Patchboard Systems</b> <b>WAGO Busbar Terminal Blocks</b>	CAGE CLAMP® 1,5 ... 16 mm <sup>2</sup> / 16 ... 6 AWG	30	3
	<b>WAGO Rail-Mount Terminal Blocks Mini</b> <b>WAGO Modular Terminal Blocks and</b> <b>WAGO Terminal Strips</b>	CAGE CLAMP® 2,5 (4) mm <sup>2</sup> / 12 AWG for DIN-35 and DIN-15 rails	34	4
	<b>WAGO Chassis-Mount Terminal Strips</b> <b>WAGO Field-Wiring Terminal Blocks</b> Side-Entry Wiring	Push-in CAGE CLAMP® 2,5 (4) mm <sup>2</sup> / 12 AWG for panel mounting	38	5
	<b>Technical Section</b>		42	6
	<b>Indexes</b> Current addresses at <a href="http://www.wago.com">www.wago.com</a>		44	7

# WAGO Rail-Mount Terminal Blocks "Classic" Operation

1



By snapping a ground conductor terminal block onto the DIN-rail, a direct electrical connection is automatically made to the rail.

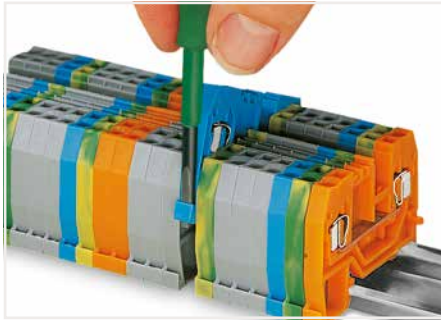

Removing a terminal block from the assembly.



**CAGE CLAMP® connection**  
Inserting a conductor.  
With ferruled conductors, it is necessary to use a terminal block one size larger than the conductor's nominal cross-section.

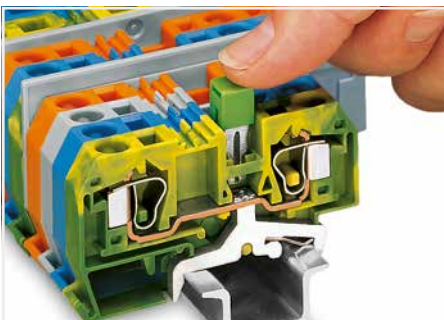

Commoning ground conductor terminal blocks with through terminal blocks is possible in one direction only (via rear side of terminal block) using adjacent jumpers. WAGO recommends using yellow-green adjacent jumpers in addition to the required marking of these blocks.

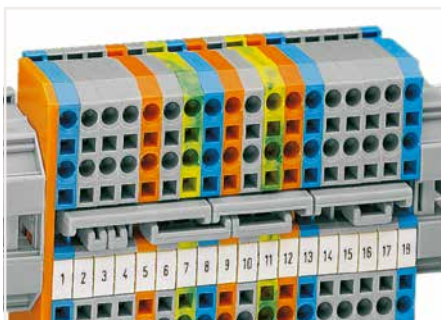

Staggered jumpers for sophisticated circuit requirements – push jumpers down until fully inserted.

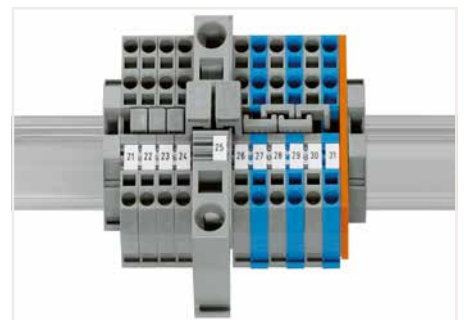

Commoning from 16 mm<sup>2</sup>/6 AWG (283 Series) to 4 mm<sup>2</sup>/12 AWG (281 Series) rail-mount terminal blocks via step-down jumpers.



Testing with a test plug – Picture shows a test plug adapter (209-170).



Testing with a test plug – (picture shows a test plug fitted with CAGE CLAMP®).



Finger guard seals an unused conductor entry.



Protective warning markers inserted into the operating slots

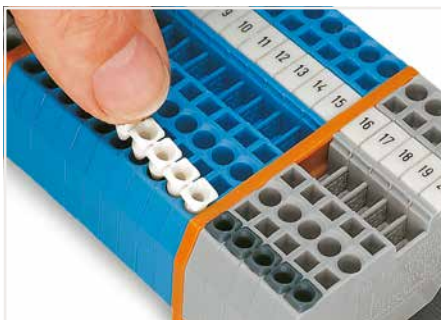









Inserting insulation stops.



Labeling via WMB Multi Marking System.

## WAGO Through/Ground/Shield Terminal Block – 279 Series

### 1,5 mm<sup>2</sup>

Image	Description	Color	Item No.	PU	Dimensions (W x H x D)	Electrical Data
<b>2-conductor through terminal block</b>						
	2-conductor through terminal block	○ gray	279-901	100	4 x 27 x 52 mm / 0.16 x 1.06 x 2.05 inch	800 V/8 kV/3 ①; I <sub>N</sub> 18 A; 600 V, 10 A ②; 600 V, 10 A ③
	2-conductor through terminal block	● blue	279-904 ②	100		
	2-conductor through terminal block	● orange	279-902	100		
	2-conductor through terminal block	● red	279-903	100		
	2-conductor through terminal block	● black	279-905	100		
	2-conductor through terminal block	● yellow	279-906	100		
	2-conductor through terminal block	○ light gray ③	279-992 ③	100		
	2-conductor ground terminal block	● green-yellow	279-907	100		
	2-conductor ground terminal block	● green-yellow ③	279-907/999-950 ③	100		
	End and intermediate plate; 2 mm thick	● orange	279-328	25	2 x 27 x 51,4 mm / 0.08 x 1.06 x 2.02 inch	
	End and intermediate plate; 2 mm thick	○ gray	279-325	25		
	End and intermediate plate; 2 mm thick	○ light gray	279-330	25		
<b>3-conductor through terminal block</b>						
	3-conductor through terminal block	○ gray	279-681	100	4 x 27 x 62,5 mm / 0.16 x 1.06 x 2.46 inch	800 V/8 kV/3 ①; I <sub>N</sub> 18 A; 600 V, 10 A ②; 600 V, 10 A ③
	3-conductor through terminal block	● blue	279-684 ②	100		
	3-conductor through terminal block	● orange	279-682	100		
	3-conductor through terminal block	● red	279-683	100		
	3-conductor through terminal block	● black	279-685	100		
	3-conductor through terminal block	● yellow	279-686	100		
	3-conductor through terminal block	○ light gray ③	279-993 ③	100		
	3-conductor ground terminal block	● green-yellow	279-687	100		
	3-conductor ground terminal block	● green-yellow ③	279-687/999-950 ③	100		
	End and intermediate plate; 2 mm thick	● orange	279-339	25	2 x 27 x 61,8 mm / 0.08 x 1.06 x 2.43 inch	
	End and intermediate plate; 2 mm thick	○ gray	279-308	25		
	End and intermediate plate; 2 mm thick	○ light gray	279-341	25		
<b>4-conductor through terminal block</b>						
	4-conductor through terminal block	○ gray	279-831	100	4 x 27 x 73 mm / 0.16 x 1.06 x 2.87 inch	800 V/8 kV/3 ①; I <sub>N</sub> 18 A; 600 V, 10 A ②; 600 V, 10 A ③
	4-conductor through terminal block	● blue	279-834 ②	100		
	4-conductor through terminal block	● orange	279-832	100		
	4-conductor through terminal block	● red	279-833	100		
	4-conductor through terminal block	● black	279-835	100		
	4-conductor through terminal block	● yellow	279-836	100		
	4-conductor through terminal block	○ light gray ③	279-994 ③	100		
	4-conductor ground terminal block	● green-yellow	279-837	100		
	4-conductor ground terminal block	● green-yellow ③	279-837/999-950 ③	100		
	End and intermediate plate; 2 mm thick	● orange	279-346	25	2 x 27 x 72,2 mm / 0.08 x 1.06 x 2.84 inch	
	End and intermediate plate; 2 mm thick	○ gray	279-344	25		
	End and intermediate plate; 2 mm thick	○ light gray	279-348	25		
<b>Double potential terminal block</b>						
	Double-potential terminal block; with double, center marking level	○ gray	279-826	100	4 x 27 x 73 mm / 0.16 x 1.06 x 2.87 inch	800 V/8 kV/3 ①; I <sub>N</sub> 18 A; 600 V, 10 A ②; 600 V, 10 A ③
		○ light gray ③	279-995 ③	100		
	End and intermediate plate; 2 mm thick	● orange	279-346	25	2 x 27 x 72,2 mm / 0.08 x 1.06 x 2.84 inch	
	End and intermediate plate; 2 mm thick	○ gray	279-344	25		
	End and intermediate plate; 2 mm thick	○ light gray	279-348	25		

Conductor range: 0.08 ... 1.5 mm<sup>2</sup>; 28 ... 16 AWG;  
Strip length: 8 ... 9 mm / 0.31 ... 0.35 inch

① 800 V = rated voltage  
8 kV = rated impulse voltage  
3 = pollution degree

Marking: WMB/WMB Inline/Marking strips











② Suitable for Ex i applications

③ Suitable for Ex e II applications; 550 V; 15 A

# WAGO Through/Ground/Shield Terminal Block – 280 Series

## 2,5 mm<sup>2</sup>

1

Image	Description	Color	Item No.	PU	Dimensions (W x H x D)	Electrical Data			
<b>2-conductor through terminal block</b>									
	2-conductor through terminal block	gray	280-901	100	5 x 28 x 53 mm / 0.2 x 1.1 x 2.09 inch	800 V/8 kV/3 ①; I <sub>n</sub> 24 A; 600 V, 20 A ②; 600 V, 25 A ③			
	2-conductor through terminal block	blue	280-904 ②	100					
	2-conductor through terminal block	orange	280-902	100					
	2-conductor through terminal block	red	280-903	100					
	2-conductor through terminal block	black	280-905	100					
	2-conductor through terminal block	yellow	280-906	100					
	2-conductor through terminal block	light gray ③	280-992 ③	100					
	2-conductor ground terminal block	green-yellow	280-907	100					
	2-conductor ground terminal block	green-yellow ③	280-907/999-950 ③	100					
		End and intermediate plate; 2 mm thick	orange	280-309			25	2,5 x 28 x 52,5 mm / 0.1 x 1.1 x 2.07 inch	
End and intermediate plate; 2 mm thick		gray	280-308	25					
End and intermediate plate; 2 mm thick		light gray	280-356	25					
<b>3-conductor through terminal block</b>									
	3-conductor through terminal block	gray	280-681	100	5 x 28 x 64 mm / 0.2 x 1.1 x 2.52 inch	800 V/8 kV/3 ①; I <sub>n</sub> 24 A; 600 V, 20 A ②; 600 V, 15 A ③			
	3-conductor through terminal block	blue	280-684 ②	100					
	3-conductor through terminal block	orange	280-650	100					
	3-conductor through terminal block	red	280-653	100					
	3-conductor through terminal block	black	280-671	100					
	3-conductor through terminal block	yellow	280-672	100					
	3-conductor through terminal block	light gray ③	280-993 ③	100					
	3-conductor ground terminal block	green-yellow	280-687	100					
	3-conductor ground terminal block	green-yellow ③	280-687/999-950 ③	100					
		End and intermediate plate; 2 mm thick	orange	280-326			25	2,5 x 26,4 x 63,8 mm / 0.1 x 1.04 x 2.51 inch	
End and intermediate plate; 2 mm thick		gray	280-324	25					
End and intermediate plate; 2 mm thick		light gray	280-358	25					
	3-conductor through terminal block	gray	280-631	100	5 x 36,5 x 50,5 mm / 0.2 x 1.44 x 1.99 inch	800 V/8 kV/3 ①; I <sub>n</sub> 24 A; 600 V, 20 A ②;			
	3-conductor through terminal block	blue	280-651 ②	100					
	3-conductor through terminal block	orange	280-654	100					
	3-conductor through terminal block	light gray ③	280-998 ③	100					
	3-conductor shield terminal block	white	280-640	100					
	3-conductor ground terminal block	green-yellow	280-637	100					
	3-conductor ground terminal block	green-yellow ③	280-637/999-950 ③	100					
		End and intermediate plate; 2,5 mm thick	orange	280-313			25	2,5 x 36,5 x 50 mm / 0.1 x 1.44 x 1.97 inch	
		End and intermediate plate; 2,5 mm thick	gray	280-312			25		
		End and intermediate plate; 2,5 mm thick	light gray	280-354			25		
<b>4-conductor through terminal block</b>									
	4-conductor through terminal block	gray	280-833	100	5 x 28 x 75 mm / 0.2 x 1.1 x 2.95 inch	800 V/8 kV/3 ①; I <sub>n</sub> 20 A; 600 V, 20 A ②; 600 V, 25 A ③			
	4-conductor through terminal block	blue	280-834 ②	100					
	4-conductor through terminal block	orange	280-835	100					
	4-conductor through terminal block	red	280-830	100					
	4-conductor through terminal block	black	280-831	100					
	4-conductor through terminal block	yellow	280-832	100					
	4-conductor through terminal block	light gray ③	280-994 ③	100					
	4-conductor ground terminal block	green-yellow	280-837	100					
	4-conductor ground terminal block	green-yellow ③	280-837/999-950 ③	100					
		End and intermediate plate; 2 mm thick	orange	280-315			25	2,5 x 28 x 75 mm / 0.1 x 1.1 x 2.96 inch	
End and intermediate plate; 2 mm thick		gray	280-314	25					
End and intermediate plate; 2 mm thick		light gray	280-352	25					
	4-conductor through terminal block	gray	280-646	100	5 x 36,5 x 50,5 mm / 0.2 x 1.44 x 1.99 inch	800 V/8 kV/3 ①; I <sub>n</sub> 24 A; 600 V, 20 A ②;			
	4-conductor through terminal block	blue	280-656 ②	100					
	4-conductor through terminal block	orange	280-946	100					
	4-conductor through terminal block	light gray ③	280-996 ③	100					
		End and intermediate plate; 2,5 mm thick	orange	280-313			25	2,5 x 36,5 x 50 mm / 0.1 x 1.44 x 1.97 inch	
		End and intermediate plate; 2,5 mm thick	gray	280-312			25		
		End and intermediate plate; 2,5 mm thick	light gray	280-354			25		

Conductor range: 0.08 ... 2.5 mm<sup>2</sup>; 28 ... 12 AWG;

Strip length: 8 ... 9 mm / 0.31 ... 0.35 inch

Accessories: see page 96

Marking: WMB/WMB Inline/Marking strips

① 800 V = rated voltage  
8 kV = rated impulse voltage  
3 = pollution degree









② Suitable for Ex i applications

③ Suitable for Ex e II; 550 V applications;  
23 A (2-conductor terminal blocks) / 22 A (3-conductor  
terminal blocks) / 20 A (4-conductor terminal blocks)



# WAGO Through/Ground/Shield Terminal Block – 281 Series

## 4 mm<sup>2</sup>

Image	Description	Color	Item No.	PU	Dimensions (W x H x D)	Electrical Data
<b>2-conductor through terminal block</b>						
	2-conductor through terminal block	○ gray	281-901	50	6 x 29 x 59,2 mm / 0.24 x 1.14 x 2.33 inch	800 V/8 kV/3 ①; I <sub>n</sub> 32 A; 600 V, 20 A ②; 600 V, 25 A ③
	2-conductor through terminal block	● blue	281-904 ②	50		
	2-conductor through terminal block	● orange	281-902	50		
	2-conductor through terminal block	● red	281-903	50		
	2-conductor through terminal block	● black	281-905	50		
	2-conductor through terminal block	● yellow	281-906	50		
	2-conductor through terminal block	○ light gray ③	281-992 ③	50		
	2-conductor ground terminal block	● green-yellow	281-907	50		
	2-conductor ground terminal block	● green-yellow ③	281-907/999-950 ③	50		
		End and intermediate plate; 2 mm thick	● orange	281-329		
End and intermediate plate; 2 mm thick		○ gray	281-328	25		
End and intermediate plate; 2 mm thick		○ light gray	281-349	25		
<b>3-conductor through terminal block</b>						
	3-conductor through terminal block	○ gray	281-681	50	6 x 29 x 73,5 mm / 0.24 x 1.14 x 2.89 inch	800 V/8 kV/3 ①; I <sub>n</sub> 32 A; 600 V, 20 A ②; 600 V, 25 A ③
	3-conductor through terminal block	● blue	281-684 ②	50		
	3-conductor through terminal block	● orange	281-678	50		
	3-conductor through terminal block	● red	281-679	50		
	3-conductor through terminal block	● black	281-685	50		
	3-conductor through terminal block	● yellow	281-686	50		
	3-conductor through terminal block	○ light gray ③	281-993 ③	50		
	3-conductor ground terminal block	● green-yellow	281-687	50		
	3-conductor ground terminal block	● green-yellow ③	281-687/999-950 ③	50		
		End and intermediate plate; 2 mm thick	● orange	281-326		
End and intermediate plate; 2 mm thick		○ gray	281-324	25		
End and intermediate plate; 2 mm thick		○ light gray	281-355	25		
	3-conductor through terminal block	○ gray	281-631	100	6 x 37 x 61,5 mm / 0.24 x 1.46 x 2.42 inch	800 V/8 kV/3 ①; I <sub>n</sub> 32 A; 600 V, 20 A ②; 600 V, 25 A ③
	3-conductor through terminal block	● blue	281-651 ②	100		
	3-conductor through terminal block	○ light gray ③	281-998 ③	100		
	3-conductor ground terminal block	● green-yellow	281-637	100		
	3-conductor ground terminal block	● green-yellow ③	281-637/999-950 ③	100		
	3-conductor shield terminal block	○ white	281-658	50		
	End and intermediate plate; 2 mm thick	● orange	281-313	25	2,5 x 37 x 61 mm / 0.1 x 1.46 x 2.4 inch	
	End and intermediate plate; 2 mm thick	○ gray	281-312	25		
	End and intermediate plate; 2 mm thick	○ light gray	281-357	25		
<b>4-conductor through terminal block</b>						
	4-conductor through terminal block	○ gray	281-652	50	6 x 29 x 86 mm / 0.24 x 1.14 x 3.39 inch	800 V/8 kV/3 ①; I <sub>n</sub> 26 A; 600 V, 20 A ②; 600 V, 25 A ③
	4-conductor through terminal block	● blue	281-654 ②	50		
	4-conductor through terminal block	● orange	281-653	50		
	4-conductor through terminal block	● red	281-663	50		
	4-conductor through terminal block	● black	281-664	50		
	4-conductor through terminal block	● yellow	281-668	50		
	4-conductor through terminal block	○ light gray ③	281-994 ③	50		
	4-conductor ground terminal block	● green-yellow	281-657	50		
	4-conductor ground terminal block	● green-yellow ③	281-657/999-950 ③	50		
		4-conductor shield terminal block	○ white	281-658		
End and intermediate plate; 2 mm thick		● orange	281-335	25		
End and intermediate plate; 2 mm thick		○ gray	281-334	25		
End and intermediate plate; 2 mm thick	○ light gray	281-345	25			

Conductor range: 0.08 ... 4 mm<sup>2</sup>; 28 ... 12 AWG;  
Strip length: 9 ... 10 mm / 0.35 ... 0.39 inch

① 800 V = rated voltage  
8 kV = rated impulse voltage  
3 = pollution degree

Marking: WMB/WMB Inline/Marking strips









② Suitable for Ex i applications

③ Suitable for Ex e II applications; 550 V; 30 A

# WAGO Through/Ground Terminal Block – 282/284 Series

## 6 / 10 mm<sup>2</sup>

1

Image	Description	Color	Item No.	PU	Dimensions (W x H x D)	Electrical Data
<b>2-conductor through terminal block; 6 mm<sup>2</sup> ①</b>						
	2-conductor through terminal block	○ gray	282-901	50	8 x 32,5 x 74,5 mm / 0.32 x 1.28 x 2.93 inch	800 V/8 kV/3 ③; I <sub>n</sub> 41 A; 600 V, 30 A ④; 600 V, 40 A ⑤
	2-conductor through terminal block	● blue	282-904 ④	50		
	2-conductor through terminal block	● orange	282-902	50		
	2-conductor through terminal block	○ light gray ⑤	282-992 ⑤	50		
	2-conductor ground terminal block	● green-yellow	282-907	50		
	2-conductor ground terminal block	● green-yellow ⑤	282-907/999-950 ⑤	50		
	End and intermediate plate; 2 mm thick	● orange	282-328	25	2,5 x 32,5 x 74,1 mm / 0.1 x 1.28 x 2.92 inch	
	End and intermediate plate; 2 mm thick	○ gray	282-325	25		
	End and intermediate plate; 2 mm thick	○ light gray	282-330	25		
<b>3-conductor through terminal block; 6 mm<sup>2</sup> ①</b>						
	3-conductor through terminal block	○ gray	282-681	25	8 x 32,5 x 93 mm / 0.32 x 1.28 x 3.66 inch	800 V/8 kV/3 ③; I <sub>n</sub> 41 A; 600 V, 30 A ④; 600 V, 40 A ⑤
	3-conductor through terminal block	● blue	282-684 ④	25		
	3-conductor through terminal block	● orange	282-682	25		
	3-conductor through terminal block	○ light gray ⑤	282-993 ⑤	50		
	3-conductor ground terminal block	● green-yellow	282-687	25		
	3-conductor ground terminal block	● green-yellow ⑤	282-687/999-950 ⑤	50		
	End and intermediate plate; 2 mm thick	● orange	282-339	25	2,5 x 32,5 x 92,8 mm / 0.1 x 1.28 x 3.65 inch	
	End and intermediate plate; 2 mm thick	○ gray	282-308	25		
	End and intermediate plate; 2 mm thick	○ light gray	282-341	25		
<b>2-conductor through terminal block; 10 mm<sup>2</sup> ②</b>						
	2-conductor through terminal block	○ gray	284-901	25	10 x 35 x 78 mm / 0.4 x 1.38 x 3.07 inch	800 V/8 kV/3 ③; I <sub>n</sub> 57 A; 600 V, 50 A ④; 600 V, 54 A ⑤
	2-conductor through terminal block	● blue	284-904	25		
	2-conductor through terminal block	● orange	284-902	25		
	2-conductor through terminal block	○ light gray ⑥	284-992 ⑥	25		
	2-conductor ground terminal block	● green-yellow	284-907	25		
	2-conductor ground terminal block	● green-yellow ⑥	284-907/999-950 ⑥	25		
	End and intermediate plate; 2 mm thick	● orange	284-328	25	2,5 x 35 x 77,5 mm / 0.1 x 1.34 x 3.05 inch	
	End and intermediate plate; 2 mm thick	○ gray	284-325	25		
	End and intermediate plate; 2 mm thick	○ light gray	284-330	25		
<b>3-conductor through terminal block; 10 mm<sup>2</sup> ②</b>						
	3-conductor through terminal block	○ gray	284-681	25	10 x 35 x 97,5 mm / 0.4 x 1.38 x 3.84 inch	800 V/8 kV/3 ③; I <sub>n</sub> 57 A; 600 V, 50 A ④; 600 V, 54 A ⑤
	3-conductor through terminal block	● blue	284-684	25		
	3-conductor through terminal block	● orange	284-682	25		
	3-conductor through terminal block	○ light gray ⑥	284-993 ⑥	25		
	3-conductor ground terminal block	● green-yellow	284-687	25		
	3-conductor ground terminal block	● green-yellow ⑥	284-687/999-950 ⑥	25		
	End and intermediate plate; 2 mm thick	● orange	284-339	25	2,5 x 35 x 97,4 mm / 0.1 x 1.34 x 3.84 inch	
	End and intermediate plate; 2 mm thick	○ gray	284-308	25		
	End and intermediate plate; 2 mm thick	○ light gray	284-341	25		

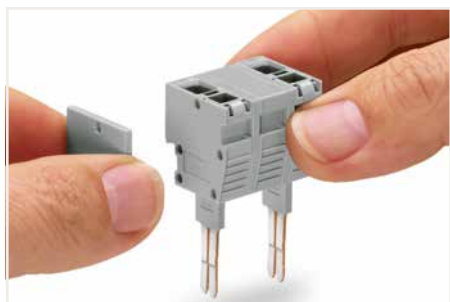

Snapping test plug and spacer modules (each with a spacer plate) together to assemble a multi-pole test plug module (max. 10 poles) for 10 mm terminal block width.

- ① Conductor range: 0.2 ... 6 mm<sup>2</sup>; 24 ... 10 AWG;  
Strip length: 12 ... 13 mm / 0.47 ... 0.51 inch
- ② Conductor range: 0.2 ... 10 mm<sup>2</sup>; 24 ... 8 AWG;  
Strip length: 12 ... 13 mm / 0.47 ... 0.51 inch



The test plug modules are directly plugged into the jumper contact slot of the current bar (picture shows 284 Series).

- ③ 800 V = rated voltage  
8 kV = rated impulse voltage  
3 = pollution degree

Marking: WMB/WMB Inline/Marking strips



Finger guard seals an unused conductor entry.

- ④ Suitable for Ex i applications
- ⑤ Suitable for Ex e II applications; 550 V; 39 A
- ⑥ Suitable for Ex e II applications; 550 V; 53 A

# WAGO Through/Ground Terminal Block – 283/285 Series

## 16 / 35 mm<sup>2</sup>

Image	Description	Color	Item No.	PU	Dimensions (W x H x D)	Electrical Data
<b>2-conductor through terminal block; 16 mm<sup>2</sup> ①</b>						
	2-conductor through terminal block	○ gray	283-901	20	12 x 37,5 x 94,5 mm / 0.47 x 1.48 x 3.72 inch	800 V/8 kV/3 ③; I <sub>n</sub> 76 A; 600 V, 65 A ④; 600 V, 70 A ⑤
	2-conductor through terminal block	● blue	283-904	20		
	2-conductor through terminal block	● orange	283-902	20		
	2-conductor through terminal block	○ light gray ⑥	283-992 ④	20		
	2-conductor ground terminal block	● green-yellow	283-907	20		
	2-conductor ground terminal block	● green-yellow ⑥	283-907/999-950 ④	20		
	End and intermediate plate; 2 mm thick	● orange	283-328	25	2,5 x 37,5 x 94,4 mm / 0.1 x 1.48 x 3.72 inch	
	End and intermediate plate; 2 mm thick	○ gray	283-325	25		
	End and intermediate plate; 2 mm thick	○ light gray	283-330	25		
<b>3-conductor through terminal block; 16 mm<sup>2</sup> ①</b>						
	3-conductor through terminal block	○ gray	283-671	20	12 x 37,5 x 104,5 mm / 0.47 x 1.48 x 4.11 inch	800 V/8 kV/3 ③; I <sub>n</sub> 76 A; 600 V, 65 A ④; 600 V, 70 A ⑤
	3-conductor through terminal block	● blue	283-674	20		
	3-conductor through terminal block	● orange	283-672	20		
	3-conductor through terminal block	○ light gray ⑥	283-998 ④	20		
	3-conductor ground terminal block	● green-yellow	283-677	20		
	3-conductor ground terminal block	● green-yellow ⑥	283-677/999-950 ④	20		
	End and intermediate plate; 2 mm thick	● orange	283-352	25	2,5 x 37,5 x 104,3 mm / 0.1 x 1.48 x 4.12 inch	
	End and intermediate plate; 2 mm thick	○ gray	283-350	25		
	End and intermediate plate; 2 mm thick	○ light gray	283-354	25		
<b>2-conductor through terminal block; 35 mm<sup>2</sup> ②</b>						
	2-conductor through terminal block	○ gray	285-635	15	16 x 53 x 100 mm / 0.63 x 2.09 x 3.94 inch	1000 V/8 kV/3 ③; I <sub>n</sub> 125 A; 600 V, 115 A ④; 600 V, 120 A ⑤
	2-conductor through terminal block	● blue	285-634	15		
	2-conductor through terminal block	○ light gray ⑥	285-992 ⑤	15		
	2-conductor ground terminal block	● green-yellow	285-637	15		
	2-conductor ground terminal block	● green-yellow ⑥	285-637/999-950 ⑤	15		



Protective warning markers inserted into the operating slots

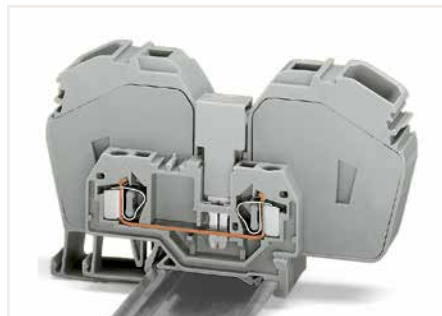

Commoning a 285 Series Terminal Block (35 mm<sup>2</sup> / 2 AWG) with a 281 Series Terminal Block (4 mm<sup>2</sup> / 12 AWG) using a step-down jumper (283-414).

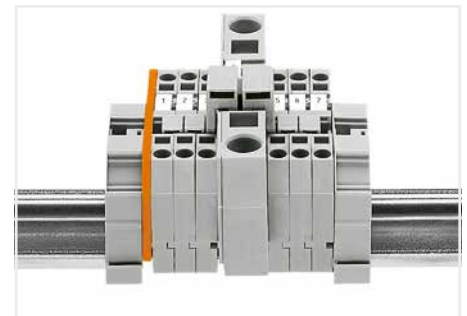

Finger guard seals an unused conductor entry.

**Step-down jumpers (overview):**

Description	Item No.	PU
from 10/6 mm <sup>2</sup> to 4/2.5/1.5 mm <sup>2</sup>	284-414	50
from 16 to 4 mm <sup>2</sup>	283-414	50
from 10/6 to 6/4 mm <sup>2</sup>	284-413	50

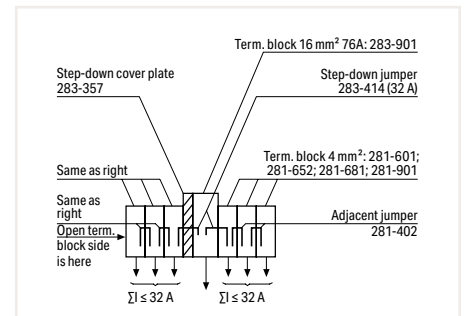

The following 285 Series Through Terminal Blocks can be commoned with 283 Series Through Terminal Blocks: 285-635 or 285-634 with 283-601 or 283-604 (terminal blocks with side marking, visit [www.wago.com](http://www.wago.com))  
Adjacent jumper required: 285-435

Please note that the nominal current of the adjacent jumper must not exceed 63 A.

- ① Conductor range: 0.2 ... 16 mm<sup>2</sup>; 24 ... 6 AWG; Strip length: 16 ... 17 mm / 0.63 ... 0.67 inch
- ② Conductor range: 6 ... 35 mm<sup>2</sup>; 8 ... 2 AWG; Strip length: 23 mm / 0.91 inch

- ③ 800/1000 V = rated voltage; 8 kV = rated impulse voltage; 3 = pollution degree



- ④ Suitable for Ex e II applications; 550 V; 68 A
- ⑤ Suitable for Ex e II applications; 880 V; 85 A

Marking: WMB/WMB Inline/Marking strips

## Distribution Terminal Block 284 Series

### 35 mm<sup>2</sup>

1

Image	Description	Color	Item No.	PU	Dimensions (W x H x D)	Electrical Data
<b>Distribution terminal block; with 3 x CAGE CLAMP® connection 10 mm<sup>2</sup> ①; 1 x Screw connection 35 mm<sup>2</sup> ②</b>						
	Distribution terminal block	○ gray	284-621	15	17,5 x 39,5 x 89 mm / 0.69 x 1.56 x 3.5 inch	800 V/8 kV/3 ③; I <sub>N</sub> 125 A;
	Distribution terminal block	● blue	284-624	15		
	Jumper; for conductor entry; 2-way; insulated	○ gray	284-412	100		



Terminating a 35 mm<sup>2</sup> (2 AWG) conductor.  
Screw clamp connection, side-entry wiring.

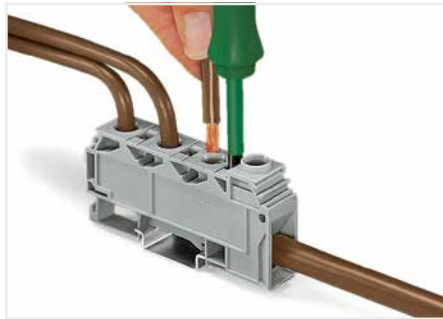

Terminating a 10 mm<sup>2</sup> (8 AWG) conductor –  
CAGE CLAMP® connection, front-entry wiring.

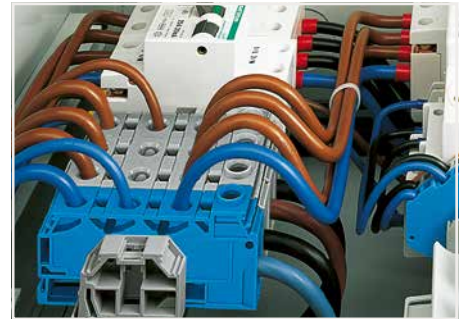

Side-entry distribution terminal block with screw clamp connection (35 mm<sup>2</sup>/2 AWG) and front-entry CAGE CLAMP® connection (3 x 10 mm<sup>2</sup>/8 AWG) snaps onto DIN-35 rail – it is enclosed on both sides and requires no end or intermediate plate.



Commoning with comb-style jumper bar.

When connecting 3 x 10 mm<sup>2</sup> (8 AWG) conductors on the distribution side, make sure that the nominal current of 125 A is not exceeded.

① Conductor range: 0.2 ... 6 mm<sup>2</sup>; 24 ... 10 AWG;  
Strip length: 12 ... 13 mm / 0.47 ... 0.51 inch

② Conductor range: 0.2 ... 6 mm<sup>2</sup>; 24 ... 10 AWG;  
Strip length: 12 ... 13 mm / 0.47 ... 0.51 inch









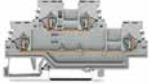

③ 800 V = rated voltage  
8 kV = rated impulse voltage  
3 = pollution degree



# WAGO Double-Deck Terminal Block – 279/280/281 Series

## 1,5 / 2,5 / 4 mm<sup>2</sup>

1

Image	Description	Color	Item No.	PU	Potential Marking	Electrical Data
<b>Double-deck terminal block; 1.5 mm<sup>2</sup> ①</b>						
	Through/through terminal block	○ gray	279-501	50	L/L	500 V/6 kV/3 ⑥; I <sub>n</sub> 18 A; 300 V, 10 A ⑨
		○ gray	279-512	50	N/L	
	Ground/through terminal block	○ gray	279-513	50	L/N	
		● blue	279-504 ⑦	50	N/N	
	4-conductor through terminal block; internally commoned; violet conductor entry	○ gray	279-517	50	GND/N	
		○ gray	279-527	50	GND/L	
4-conductor ground terminal block; internally commoned	○ gray	279-508	50	L		
	● blue	279-509 ⑦	50	N		
	End and intermediate plate; 2 mm thick	● green-yellow	279-507	50	GND	
		● orange	279-519	25		
		○ gray	279-518	25		
<b>Double-deck terminal block; 2.5 mm<sup>2</sup> ②</b>						
	Through/through terminal block	○ gray	280-519	50		500 V/6 kV/3 ⑥; I <sub>n</sub> 20 A; 300 V, 15 A ⑨; 300 V, 20 A ⑩
		● blue	280-529 ⑦	50		
	Ground/through terminal block	■ blue/gray	280-523	50		
■ gray/blue		280-533	50			
4-conductor ground terminal block; internally commoned	■ green-yellow/gray	280-527	50			
	■ green-yellow/gray	280-537	50			
	End and intermediate plate; 2 mm thick	● green-yellow	280-517	50		
		● orange	280-341	25		
		○ gray	280-340	25		
<b>Double-deck terminal block; with slot for adjacent jumper; 2.5 mm<sup>2</sup> ③</b>						
	Through/through terminal block; with slot for adjacent jumper	○ gray	280-520	50		500 V/6 kV/3 ⑥; I <sub>n</sub> 20 A; 300 V, 15 A ⑨; 300 V, 20 A ⑩
		● blue	280-530 ⑦	50		
		■ blue/gray	280-524	50		
		■ gray/blue	280-534	50		
	End and intermediate plate; 2 mm thick	● orange	280-343	25		
		○ gray	280-342	25		
<b>Double-deck terminal block; 4 mm<sup>2</sup> ④</b>						
	Through/through terminal block	○ gray	281-619	50		500 V/6 kV/3 ⑥; I <sub>n</sub> 26 A; 600 V, 20 A ⑨; 600 V, 25 A ⑩
		● blue	281-629	50		
	End and intermediate plate; 2.5 mm thick	● orange	281-341	25		
		○ gray	281-340	25		
<b>Double-deck terminal block; with slot for adjacent jumper; 4 mm<sup>2</sup> ⑤</b>						
	Through/through terminal block; with slot for adjacent jumper	○ gray	281-620	50		500 V/6 kV/3 ⑥; I <sub>n</sub> 26 A; 600 V, 20 A ⑨; 600 V, 25 A ⑩
		● blue	281-630	50		
	End and intermediate plate; 2.5 mm thick	● orange	281-343	25		
		○ gray	281-342	25		

① Dimensions (W x H x D):  
4 x 39 x 85 mm / 0.157 x 1.54 x 3.35 inch;  
Conductor range: 0.08 ... 1.5 mm<sup>2</sup> 28 ... 12 AWG;  
Strip length: 8 ... 9 mm / 0.31 ... 0.35 inch

② Dimensions (W x H x D):  
5 x 58.5 x 64 mm / 0.197 x 2.3 x 2.52 inch;  
Conductor range: 0.08 ... 2.5 mm<sup>2</sup> 28 ... 12 AWG;  
Strip length: 8 ... 9 mm / 0.31 ... 0.35 inch

③ Dimensions (W x H x D):  
5 x 58.5 x 74 mm / 0.197 x 2.3 x 2.91 inch;  
Conductor range: 0.08 ... 2.5 mm<sup>2</sup> 28 ... 12 AWG;  
Strip length: 8 ... 9 mm / 0.31 ... 0.35 inch

④ Dimensions (W x H x D):  
6 x 58.5 x 73.5 mm / 0.236 x 2.3 x 2.89 inch;  
Conductor range: 0.08 ... 4 mm<sup>2</sup> 28 ... 12 AWG;  
Strip length: 9 ... 10 mm / 0.35 ... 0.39 inch





⑤ Dimensions (W x H x D):  
6 x 58.5 x 83.5 mm / 0.236 x 2.3 x 3.29 inch;  
Conductor range: 0.08 ... 4 mm<sup>2</sup> 28 ... 12 AWG;  
Strip length: 9 ... 10 mm / 0.35 ... 0.39 inch

⑥ 500 V = rated voltage  
6 kV = rated impulse voltage  
3 = pollution degree  
⑦ Suitable for Ex i applications

Marking: WMB/WMB Inline/Marking strips

# WAGO Triple-Deck Terminal Block; Quadruple-Deck Rail-Mount Terminal Block for Electric Motor Wiring – 280/281 Series

## 2,5 / 4 mm<sup>2</sup>

Image	Description	Color	Item No.	PU	Potential Marking	Electrical Data
<b>Triple-deck terminal block; 2.5 mm<sup>2</sup> ①</b>						
	Through/through/through terminal block	○ gray ● blue	280-549 280-551	40 40		500 V/6 kV/3 ④; I <sub>n</sub> 20 A; 300 V, 15 A ⑤; 300 V, 20 A ⑥
	Ground/through/through terminal block	■ gray/gray/blue ■ green-yellow/gray/blue	280-552 280-547	40 40		
	Shield/through/through terminal block	■ green-yellow/blue/gray ■ white/gray/blue ■ white/blue/gray	280-557 280-548 280-558	40 40 40		
	6-conductor ground terminal block; internally commoned	● green-yellow	280-597	40		
	End and intermediate plate; 2 mm thick	● orange ○ gray	280-304 280-303	25 25		
<b>Triple-deck terminal block; with slot for adjacent jumper; 2.5 mm<sup>2</sup> ②</b>						
	Through/through/through terminal block with additional jumper position on lower level	○ gray	280-550	40		500 V/6 kV/3 ④; I <sub>n</sub> 20 A; 300 V, 15 A ⑤; 300 V, 20 A ⑥
	End and intermediate plate; 2 mm thick	● orange ○ gray	280-306 280-305	25 25		
<b>Quadruple-deck rail-mount terminal block for electric motor wiring; 4 mm<sup>2</sup> ③</b>						
	Quadruple-deck rail-mount terminal block; Rail-mount terminal block for electric motor wiring	○ gray	281-530	50	L1 - L2 - L3 - GND	400 V/6 kV/3 ④; I <sub>n</sub> 20 A; 600 V, 20 A ⑤; 300 V, 25 A ⑥
		○ gray	281-531	50	L1 - L2	
		○ gray	281-532	50	L1 - L2 - L3	
	End and intermediate plate; 2 mm thick	● orange	281-366	25		
		○ gray	281-365	25		

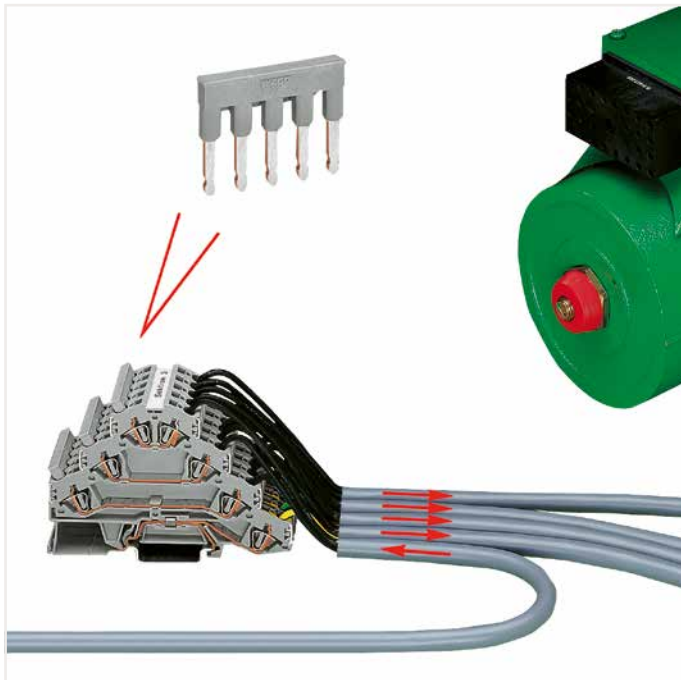

In addition to rail-mount terminal blocks for electric motor wiring, special versions are also available:

- Version **without** ground contact and only two potentials: These terminal blocks were custom designed to support additional functions, such as engine brakes or temperature sensors. Sharing a common profile, this terminal block version can be put next to the appropriate electric motor wiring terminal block without using intermediate plates. That makes the rail assembly easier to understand and wire. This also prevents wiring errors as no conductor entry is unused.
- Version **without** ground contact and with three potentials: Clearly designated clamping units are the primary advantage to this terminal block design. When using devices with protective insulation, for example, there are no open ground clamping units that could create confusion.

① Dimensions (W x H x D):  
4 x 39 x 85 mm / 0.157 x 1.54 x 3.35 inch;  
Conductor range: 0.08 ... 1.5 mm<sup>2</sup> 28 ... 16 AWG;  
Strip length: 8 ... 9 mm / 0.31 ... 0.35 inch

② Dimensions (W x H x D):  
5 x 58.5 x 74 mm / 0.197 x 2.3 x 2.91 inch;  
Conductor range: 0.08 ... 2.5 mm<sup>2</sup> 28 ... 12 AWG;  
Strip length: 8 ... 9 mm / 0.31 ... 0.35 inch

③ Dimensions (W x H x D):  
6 x 58.5 x 83.5 mm / 0.236 x 2.3 x 3.29 inch;  
Conductor range: 0.08 ... 4 mm<sup>2</sup> 28 ... 12 AWG;  
Strip length: 9 ... 10 mm / 0.35 ... 0.39 inch

④ 400/500 V = rated voltage;  
6 kV = rated impulse voltage;  
3 = pollution degree

Marking: WMB/WMB Inline/Marking strips

# WAGO Rail-Mount Terminal Block with Side-Entry Wiring – 279/280/281/282/283/284 Series

## 1,5 / 2,5 / 4 / 6 / 10 / 16 mm<sup>2</sup>

Image	Description	Color	Item No.	PU	Dimensions (W x H x D)	Electrical Data
<b>2-conductor through terminal block; 4 mm<sup>2</sup> ①</b>						
	2-conductor through terminal block	○ gray	279-101	100	4 x 30,5 x 42,5 mm / 0.16 x 1.2 x 1.67 inch	800 V/8 kV/3 ⑥; I <sub>n</sub> 18 A; 600 V, 10 A ⑦; 600 V, 15 A ⑧
	2-conductor through terminal block	● blue	279-104 ⑦	100		
	End and intermediate plate; 2.5 mm thick	● orange	280-302	25	2,5 x 30 x 38 mm /	
		○ gray	280-301	25	0.1 x 1.18 x 1.5 inch	
<b>2-conductor through terminal block; 5 mm<sup>2</sup> ②</b>						
	2-conductor through terminal block	○ gray	280-101	100	5 x 30,5 x 42,5 mm / 0.2 x 1.2 x 1.67 inch	800 V/8 kV/3 ⑥; I <sub>n</sub> 24 A; 600 V, 20 A ⑦; 600 V, 20 A ⑧
	2-conductor through terminal block	● blue	280-104 ⑦	100		
	2-conductor ground terminal block	● yellow-green	280-107	100		
	End and intermediate plate; 2.5 mm thick	● orange	280-302	25	2,5 x 30 x 38 mm /	
		○ gray	280-301	25	0.1 x 1.18 x 1.5 inch	
<b>2-conductor through terminal block; 6 mm<sup>2</sup> ③</b>						
	2-conductor through terminal block	○ gray	281-101	100	6 x 32,5 x 42,5 mm / 0.24 x 1.28 x 1.67 inch	800 V/8 kV/3 ⑥; I <sub>n</sub> 32 A; 600 V, 20 A ⑦; 600 V, 25 A ⑧
	2-conductor through terminal block	● blue	281-104 ⑦	100		
	2-conductor ground terminal block	● yellow-green	281-107	100		
	End and intermediate plate; 3 mm thick	● orange	281-302	25	3 x 32 x 40 mm /	
		○ gray	281-301	25	0.12 x 1.26 x 1.56 inch	
<b>2-conductor through terminal block; 8 mm<sup>2</sup> ④</b>						
	2-conductor through terminal block	○ gray	282-101	50	8 x 37 x 46,5 mm / 0.32 x 1.46 x 1.83 inch	800 V/8 kV/3 ⑥; I <sub>n</sub> 41 A; 600 V, 30 A ⑦; 600 V, 10 A ⑧
	2-conductor through terminal block	● blue	282-104 ⑦	50		
	2-conductor ground terminal block	● yellow-green	282-107	50		
	End and intermediate plate; 4 mm thick	● orange	282-302	25	4 x 36,5 x 46 mm /	
		○ gray	282-301	25	0.16 x 1.44 x 1.81 inch	
<b>2-conductor through terminal block; 10 mm<sup>2</sup> ⑤</b>						
	2-conductor through terminal block	○ gray	284-101	50	10 x 41,5 x 52 mm / 0.4 x 1.63 x 2.05 inch	800 V/8 kV/3 ⑥; I <sub>n</sub> 57 A; 600 V, 50 A ⑦; 600 V, 65 A ⑧
	2-conductor through terminal block	● blue	284-104 ⑦	50		
	2-conductor ground terminal block	● yellow-green	284-107	50		
	End and intermediate plate; 2.5 mm thick	● orange	284-302	25	2,5 x 40 x 52 mm /	
		○ gray	284-301	25	0.1 x 1.56 x 2.05 inch	
<b>2-conductor through terminal block; 16 mm<sup>2</sup> ⑥</b>						
	2-conductor through terminal block	○ gray	283-101	50	12 x 45,5 x 58 mm / 0.47 x 1.79 x 2.28 inch	800 V/8 kV/3 ⑥; I <sub>n</sub> 76 A; 600 V, 65 A ⑦; 600 V, 90 A ⑧
	2-conductor through terminal block	● blue	283-104 ⑦	50		
	2-conductor ground terminal block	● yellow-green	283-107	50		
	End and intermediate plate; 4 mm thick	● orange	283-302	25	4 x 44 x 58 mm /	
		○ gray	283-301	25	0.16 x 1.73 x 2.28 inch	

① Conductor range: 0.08 ... 1.5 mm<sup>2</sup>; 28 ... 16 AWG;  
Strip length: 8 ... 9 mm / 0.31 ... 0.35 inch

② Conductor range: 0.08 ... 2.5 mm<sup>2</sup>; 28 ... 12 AWG;  
Strip length: 8 ... 9 mm / 0.31 ... 0.35 inch

③ Conductor range: 0.08 ... 4 mm<sup>2</sup>; 28 ... 12 AWG;  
Strip length: 9 ... 10 mm / 0.35 ... 0.39 inch

④ Conductor range: 0.2 ... 6 mm<sup>2</sup>; 24 ... 10 AWG;  
Strip length: 12 ... 13 mm / 0.47 ... 0.51 inch

⑤ Conductor range: 0.2 ... 10 mm<sup>2</sup>; 24 ... 8 AWG;  
Strip length: 12 ... 13 mm / 0.47 ... 0.51 inch

⑥ Conductor range: 0.2 ... 16 mm<sup>2</sup>; 24 ... 6 AWG;  
Strip length: 16 ... 17 mm / 0.63 ... 0.67 inch

Marking: WMB/WMB Inline/Marking strips

⑥ 800 V = rated voltage  
8 kV = rated impulse voltage  
3 = pollution degree

⑦ Suitable for Ex i applications



# WAGO Disconnect/Test/Fuse Terminal Block with Side-Entry Wiring – 282 Series

## 6 mm<sup>2</sup>

Image	Description	Color	Item No.	PU	Dimensions (W x H x D)	Electrical Data
<b>Disconnect/test terminal block</b>						
	Disconnect/test terminal block; with 4 mm Ø test sockets	○ gray	282-131	25	8 x 37 x 87,5 mm / 0.32 x 1.46 x 3.44 inch	400 V/6 kV/3 ①; I <sub>n</sub> 41 A; 300 V, 30 A ②; 300 V, 40 A ③
	Through terminal block	○ gray	282-133	25		
	Disconnect/test terminal block; without test sockets	○ gray	282-135	25		
	Ground conductor disconnect terminal block ② (For additional notes, see page 47.)					
	24 VAC/DC	○ gray	282-140	12	16 x 38,5 x 87,5 mm / 0.63 x 1.52 x 3.44 inch	
	48 VAC/DC	○ gray	282-141	12		
	120 VAC/DC	○ gray	282-138	12		
	230 VAC/VDC	○ gray	282-139	12		
	Lock-out; prevents reclosing of slide link; snap-on type	● orange	282-137	25		
	End and intermediate plate; 4 mm thick	● orange	282-315	25	4 x 37 x 85 mm /	
		○ gray	282-314	25	0.16 x 1.46 x 3.35 inch	
<b>Fuse terminal block</b>						
	2-conductor fuse terminal block; for 5 x 20 mm glass cartridge fuses; without indicator	○ gray	282-122	40	13 x 54,5 x 62 mm / 0.51 x 2.15 x 2.44 inch	500 V/6 kV/3 ①; I <sub>n</sub> 10 A; 600 V, 10 A ②; 250 V, 10 A ③
	2-conductor fuse terminal block, for 1/4" x 1" cartridge fuses; without indicator	○ gray	282-120	40	13 x 56,5 x 62 mm / 0.51 x 2.22 x 2.44 inch	
	2-conductor fuse terminal block, for 1/4" x 1 1/4" cartridge fuses; without indicator	○ gray	282-128	40	13 x 56,5 x 62 mm / 0.51 x 2.22 x 2.44 inch	
	2-conductor fuse terminal block; for 5 x 25 mm glass cartridge fuses; with indicator	○ gray	282-126	40	13 x 54,5 x 62 mm / 0.51 x 2.15 x 2.44 inch	
	2-conductor fuse terminal block; for 1/4" x 1 1/4" glass cartridge fuses; with red LED	○ gray	282-128/281-413	40	13 x 56,5 x 62 mm / 0.51 x 2.22 x 2.44 inch	
	2-conductor fuse terminal block; for 1/4" x 1 1/4" glass cartridge fuses; with 250 VAC/220 VDC neon lamp	○ gray	282-128/281-417	40	13 x 56,5 x 62 mm / 0.51 x 2.22 x 2.44 inch	
	2-conductor fuse terminal block; for (5 x 20) mm glass cartridge fuses; with 250 VAC/220 VDC neon lamp	○ gray	282-124	40	13 x 54,5 x 62 mm / 0.51 x 2.15 x 2.44 inch	
	22-conductor fuse terminal block; for 1/4" x 1 1/4" glass cartridge fuses; with 120 VAC/DC neon lamp	○ gray	282-128/281-418	40	13 x 56,5 x 62 mm / 0.51 x 2.22 x 2.44 inch	
	End and intermediate plate; 4 mm thick	● orange	282-312	25	4 x 46,4 x 62 mm /	
		○ gray	282-311	25	0.16 x 1.83 x 2.44 inch	

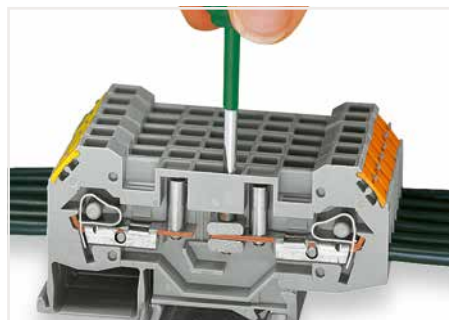

Shifting the disconnect slide link of a disconnect/test terminal block.



When operating the handles beyond the locked position, the ratchet allows the tool to open and be removed from the terminal block.

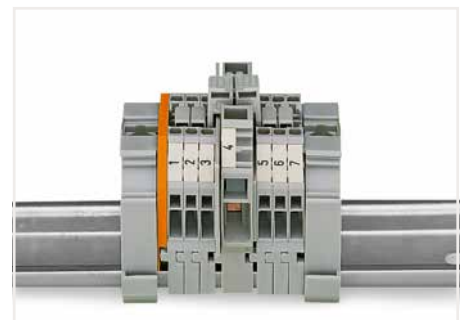

Commoning from 6 mm<sup>2</sup>/10 AWG (282 Series) to 1.5 mm<sup>2</sup>/16 AWG (279 Series) rail-mount terminal blocks via step-down jumpers.

Conductor range: 0.2 ... 6 mm<sup>2</sup>; 24 ... 10 AWG;  
Strip length: 12 ... 13 mm / 0.47 ... 0.51 inch











① 400/500 V = rated voltage;  
8 kV = rated impulse voltage;  
3 = pollution degree

Marking: WMB/WMB Inline/Marking strips

② Nominal voltage and current are given by the fuse or blown fuse indicator!

# WAGO Disconnect/Test Terminal Block; WAGO Through Terminal Block of Same Profile; WAGO Ground Conductor Disconnect Terminal Block 2,5 / 6 mm<sup>2</sup>; Serie 280 / 282

1

Image	Description	Color	Item No.	PU	Dimensions (W x H x D)	Electrical Data
<b>2-conductor disconnect/test terminal block; 2.5 mm<sup>2</sup> ①</b>						
	2-conductor disconnect/test terminal block; with test slots for 2 and 2.3 mm Ø test plugs; with pivoting knife disconnect	○ gray	280-870	100	5 x 45,5 x 69,5 mm / 0.2 x 1.79 x 2.74 inch	400 V/6 kV/3 ③; I <sub>N</sub> 16 A; 600 V, 15 A ⑤; 300 V, 15 A ⑥
○ gray		280-868	100			
● blue ④		280-876	100			
● orange		280-879	100			
	2-conductor disconnect/test terminal block; with test slots for 2 and 2.3 mm Ø test plugs; with pivoting knife disconnect	○ gray	280-871	100	5 x 45,5 x 82 mm / 0.2 x 1.79 x 3.23 inch	250 V/4 kV/3 ③; I <sub>N</sub> 16 A; 600 V, 15 A ⑤; 300 V, 15 A ⑥
○ gray		280-869	100			
● blue		280-880	100			
	End and intermediate plate; 2.5 mm thick	● orange	280-371	25	2,5 x 28,5 x 69,4 mm /	
		○ gray	280-374	25	01 x 1.12 x 2.73 inch	
<b>4-conductor disconnect/test terminal block; 2.5 mm<sup>2</sup> ①</b>						
	4-conductor disconnect/test terminal block; with test slots for 2 and 2.3 mm Ø test plugs; with pivoting knife disconnect	○ gray	280-874	100	5 x 45,5 x 89 mm / 0.2 x 1.79 x 3.5 inch	400 V/6 kV/3 ③; I <sub>N</sub> 16 A; 600 V, 15 A ⑤; 300 V, 15 A ⑥
○ gray		280-881	100			
● blue ④		280-885	100			
● orange		280-883	100			
	4-conductor disconnect/test terminal block; with test slots for 2 and 2.3 mm Ø test plugs; with pivoting knife disconnect	○ gray	280-875	100	5 x 45,5 x 101 mm / 0.2 x 1.79 x 3.98 inch	250 V/4 kV/3 ③; I <sub>N</sub> 16 A; 600 V, 15 A ⑤; 300 V, 15 A ⑥
○ gray		280-882	100			
● blue		280-884	100			
	End and intermediate plate; 2.5 mm thick	● orange	280-373	25	2,5 x 28,5 x 88,9 mm /	
		○ gray	280-376	25	01 x 1.12 x 3,5 inch	
<b>Disconnect and ground conductor disconnect terminal block; 6 mm<sup>2</sup> ②</b>						
	2-conductor disconnect terminal block; with test point	○ gray	282-697	25	8 x 50,5 x 85 mm / 0.32 x 1.99 x 3.35 inch	400 V/6 kV/3 ③; I <sub>N</sub> 30 A; 600 V, 30 A ⑤; 300 V, 35 A ⑥
● blue		282-695	25			
	3-conductor through terminal block; with test point; same profile as disconnect terminal blocks	○ gray	282-699	25	8 x 32,5 x 85 mm / 0.32 x 1.28 x 3.35 inch	800 V/8 kV/3 ③; I <sub>N</sub> 41 A; 600 V, 30 A ⑤; 300 V, 35 A ⑥
● blue	282-694	25				
	Ground conductor disconnect terminal block; with test point ⑤ (For additional notes, see page 47.)					
	24 VAC/DC	○ gray	282-640	12	16 x 32,5 x 85 mm / 0.32 x 1.28 x 3.35 inch	
	48 VAC/DC	○ gray	282-641	12		
	120 VAC/DC	○ gray	282-638	12		
	230 VAC/VDC	○ gray	282-639	12		
	End and intermediate plate; 2 mm thick	● orange	282-333	25	2 x 26,1 x 84,5 mm /	
		○ gray	282-334	25	0.08 x 1.03 x 3.33 inch	

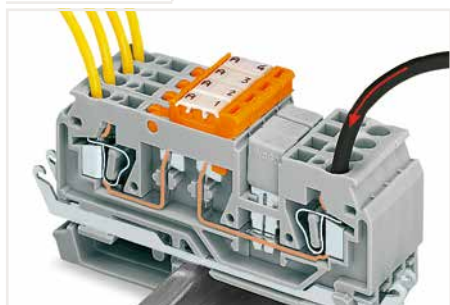

Power distribution using an adjacent jumper – knife disconnect used to disconnect individual outputs.



Power distribution using disconnect link in supply line – disconnection of all outputs.

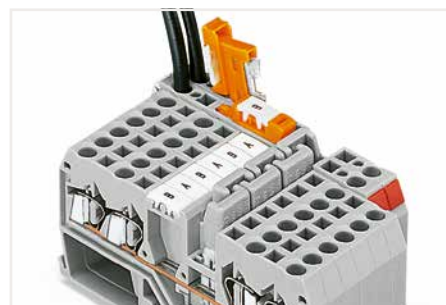

Staggered jumpers for sophisticated circuit requirements – push jumpers down until fully inserted.

① Conductor range: 0.08 ... 2.5 mm<sup>2</sup>; 28 ... 12 AWG;  
Strip length: 8 ... 9 mm / 0.31 ... 0.35 inch

















② Conductor range: 0.2 ... 6 mm<sup>2</sup>; 24 ... 10 AWG;  
Strip length: 12 ... 13 mm / 0.47 ... 0.51 inch

③ 400/800 V = rated voltage;  
6/8 kV = rated impulse voltage;  
3 = pollution degree

④ Suitable for Ex i applications  
Marking: WMB/WMB Inline/Marking strips

⑤ Nominal voltage and current are given by the fuse or blown fuse indicator!

## WAGO Disconnect/Test/Through Terminal Block; for Current/Voltage Transformer Circuits 6 mm<sup>2</sup>; 282 Series

Image	Description	Color	Item No.	PU	Dimensions (W x H x D)	Electrical Data
<b>2-conductor disconnect/test and through terminal block for current/ voltage transformer circuits</b>						
	2-conductor disconnect/test terminal block; transverse switching; with touch-proof test socket; for 4 mm Ø test plug	○ gray	282-811	20	8 x 37,5 x 89 mm / 0.32 x 1.48 x 3.5 inch	500 V/6 kV/3 ①; I <sub>N</sub> 30 A; 600 V, 30 A ②; 300 V, 36 A ③
	Jumper with safety flap; insulated; I <sub>N</sub> 30 A					
	2-way	● orange	282-432/100-000	10		
	3-way	● orange	282-433/100-000	10		
	4-way	● orange	282-434/100-000	10		
	End and separator plate; 1.5 mm thick	● orange ○ gray	282-366 282-361	25 25	1,5 x 37,5 x 89 mm / 0.06 x 1.48 x 3.5 inch	
	2-conductor disconnect/test terminal block; longitudinal switching; with touch-proof test sockets; for 4 mm Ø test plugs	○ gray	282-821	20		500 V/6 kV/3 ①; I <sub>N</sub> 30 A; 600 V, 30 A ②; 300 V, 36 A ③
	2-conductor through terminal block; with touch-proof test sockets; for 4 mm Ø test plugs	○ gray	282-841	20	8 x 46,5 x 98 mm / 0.32 x 1.83 x 3.86 inch	500 V/6 kV/3 ①; I <sub>N</sub> 30 A
	2-conductor through terminal block; without test sockets	○ gray	282-841/049-000	20		
	End and separator plate; 1.5 mm thick	● orange ○ gray	282-365 282-360	25 25	1,5 x 46,5 x 98 mm / 0.06 x 1.83 x 3.86 inch	
<b>3-conductor disconnect/test and through terminal block for current/ voltage transformer circuits</b>						
	3-conductor disconnect/test terminal block; with touch-proof test sockets; for 4 mm Ø test plugs; e.g., for current transformer circuits; orange disconnect link	○ gray	282-870	20	8 x 75 x 122 mm / 0.32 x 2.95 x 4.8 inch	500 V/6 kV/3 ①; I <sub>N</sub> 30 A; 600 V, 30 A ②; 300 V, 5 A ③
	Adjacent jumper; insulated	● orange	282-424	25		I <sub>N</sub> 41 A
	3-conductor disconnect/test terminal block; with touch-proof test sockets; for 4 mm Ø test plugs; e.g., for voltage transformer circuits; light gray disconnect link	○ gray	282-860	20	8 x 75 x 122 mm / 0.32 x 2.95 x 4.8 inch	500 V/6 kV/3 ①; I <sub>N</sub> 30 A; 600 V, 30 A ②; 300 V, 5 A ③
	End and separator plate; 1.5 mm thick; without lock-out seal option	● orange ○ gray	282-386 282-391	10 10	1,5 x 71,7 x 122 mm / 0.06 x 2.82 x 4.8 inch	
	End and separator plate; 1.5 mm thick; with lock-out seal option	● orange ○ gray	282-387 282-392	10 10		
	3-conductor through terminal block; with touch-proof test socket; for 4 mm Ø test plugs; e.g., for current transformer circuits	○ gray	282-865	20		500 V/6 kV/3 ①; I <sub>N</sub> 30 A; 600 V, 30 A ②; 300 V, 5 A ③
	3-conductor through terminal block; with touch-proof test socket; for 4 mm Ø test plugs; e.g., for voltage transformer circuits	○ gray	282-866	20	8 x 74 x 122 mm / 0.32 x 2.91 x 4.8 inch	
	3-conductor through terminal block; with touch-proof test socket; for 4 mm Ø test plugs; e.g., for voltage transformer circuits	● green-yellow	282-868	20		
	End and intermediate plate; 1.5 mm thick	● orange ○ gray	282-385 282-390	10 10	1,5 x 65,6 x 122 mm / 0.06 x 2.58 x 4.8 inch	

Conductor range: 0.2 ... 6 mm<sup>2</sup>; 24 ... 10 AWG;  
Strip length: 12 ... 13 mm / 0.47 ... 0.51 inch

① 500 V = rated voltage  
6 kV = rated impulse voltage  
3 = pollution degree

Marking: WMB/WMB Inline/Marking strips

# WAGO Fused Terminal Blocks with a Pivoting Fuse Holder; WAGO Fuse Terminal Blocks for Mini-Automotive Blade-Style Fuses; Fuse Terminal Blocks for Cylindrical Fuses; 282/811 Series Description and Installation

1



Blown fuse indication by LED or neon lamp

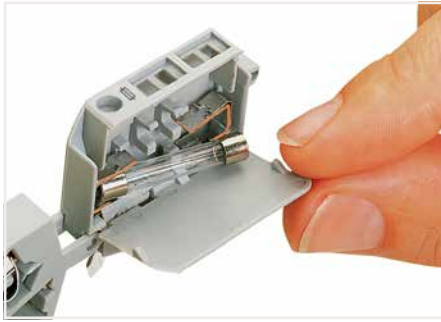

**Fuse replacement:**  
One end of the fuse is automatically ejected from the holder when opening the cover.



Storing a spare fuse (fuse holder without blown fuse indication).

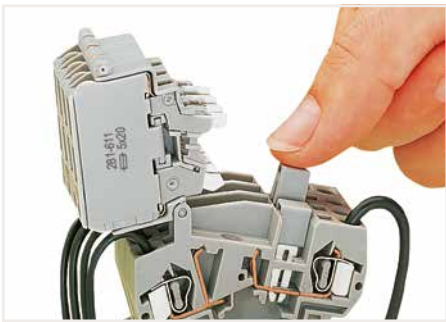

**Commoning**  
Distributing current to several fuse-protected circuits via insulated push-in type jumpers.

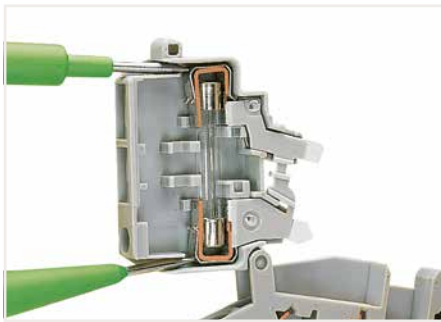

Through test with fuse holder in open position (no voltage)



Measuring current between jumper slot and separate test slot.

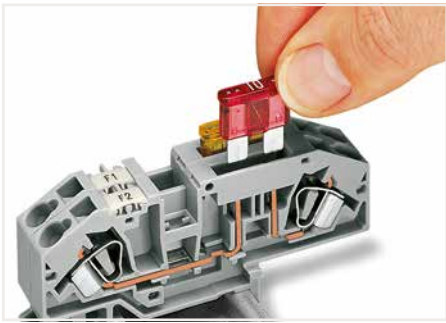

Inserting a fuse.



Blown fuse indication via LED.

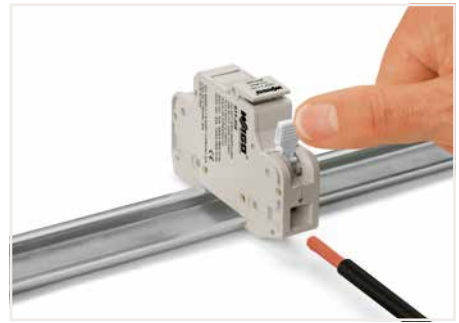

**CAGE CLAMP® connection**  
Inserting a conductor.  
Opening the clamping unit via integrated lever.



WMB marker slot for convenient identification



Inserting a fuse.



Creating a 2- or 3-pole fuse terminal block via coupling kit.

# WAGO Sensor Terminal Blocks and WAGO Actuator Terminal Blocks

## 280 Series

### Description and Installation

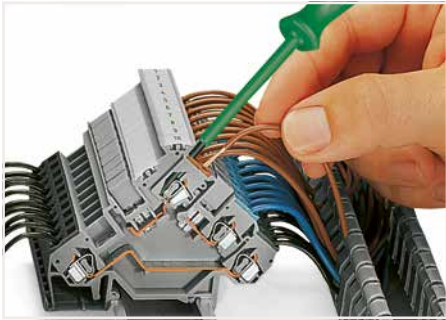

**CAGE CLAMP® connection**  
Inserting a conductor via straight operating tool (210-720).

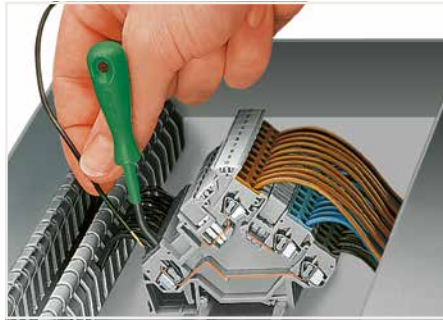

**CAGE CLAMP® connection**  
Inserting a conductor via angled operating tool (210-658).

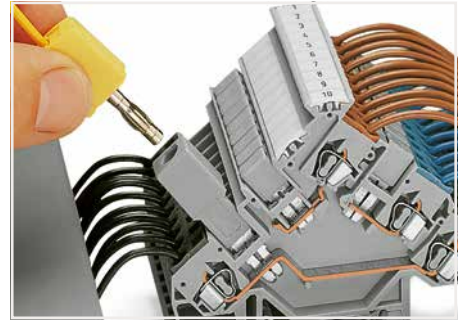

Testing via banana plug and test plug adapter (209-170).

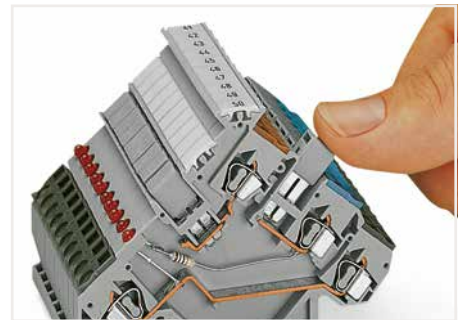
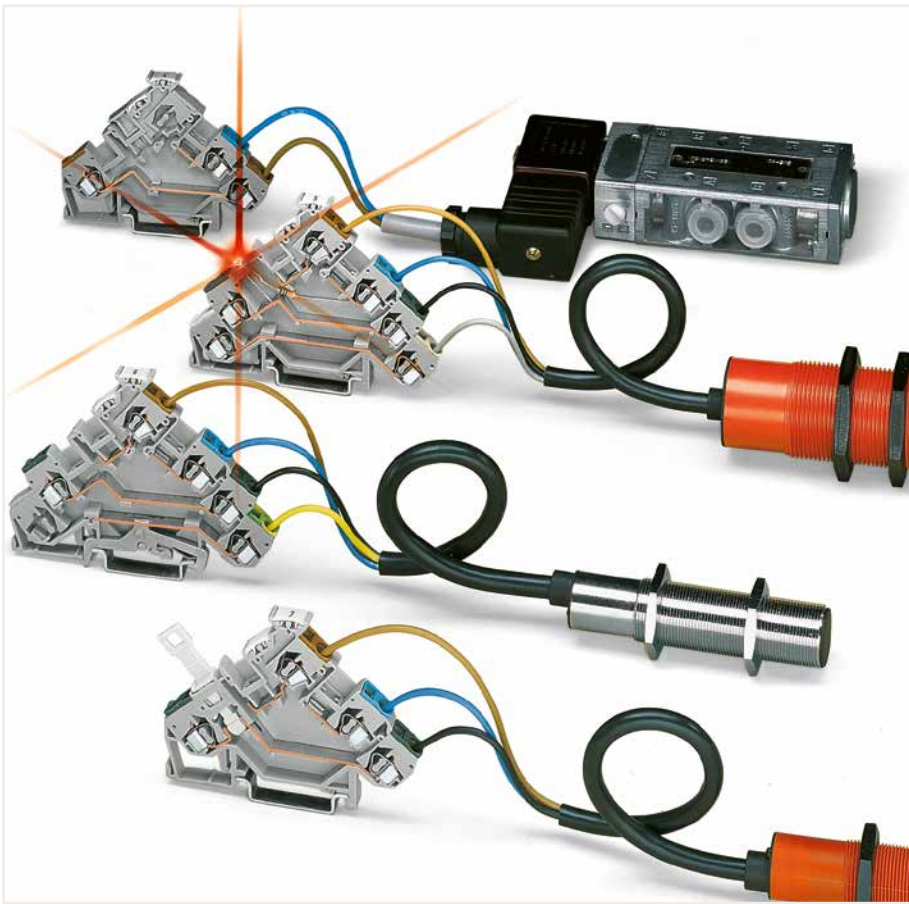

Commoning using an adjacent jumper (280-402).  
Push jumper down until fully inserted.

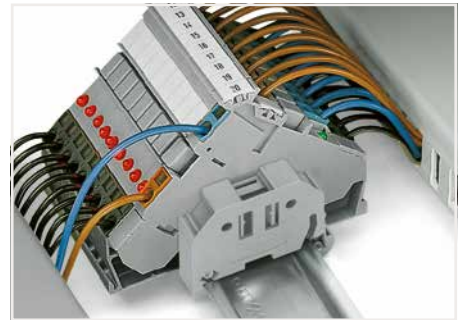

Sensor terminal blocks  
Power supply from control panel side

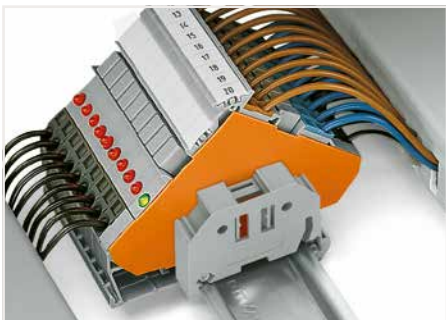

Sensor terminal blocks  
Power supply from sensor side



Testing via voltage tester directly on the current bar.









Actuator terminal blocks with fuse holders (281-511) –  
intermediate plates are required!

# WAGO Fuse terminal block

## 4/6 mm<sup>2</sup>; 281/282 Series

1

Image	Description	Color	Item No.	PU	Dimensions (W x H x D)	Electrical Data
<b>Fused disconnect terminal block with a pivoting fuse holder ①</b>						
	Fused disconnect terminal block with a pivoting fuse holder; without blown fuse indication					
	for (5 x 20) mm glass cartridge fuse	○ gray	281-611	50		
	for (5 x 20) mm glass cartridge fuse	● orange	281-616	50	8 x 60 x 60 mm / 0.32 x 2.36 x 2.36 inch	800 V/8 kV/3 ④; I <sub>n</sub> 10 A; 600 V, 10 A ⑤; 600 V, 10 A ⑥
	for (5 x 25) mm glass cartridge fuse	○ gray	281-612	50		
	for (5 x 30) mm glass cartridge fuse	○ gray	281-622	50		
	for 1/4" x 1" glass cartridge fuse	○ gray	281-613	50	10 x 60 x 60 mm / 0.39 x 2.36 x 2.36 inch	
for 1/4" x 1 1/4" glass cartridge fuse	○ gray	281-623	50			
	Fused disconnect terminal block with a pivoting fuse holder; with blown fuse indication by LED					
	for (5 x 20) mm glass cartridge fuse; 15 ... 30 V	○ gray	281-611/281-541	50		
	for (5 x 20) mm glass cartridge fuse; 30 ... 65 V	○ gray	281-611/281-542	50	8 x 60 x 60 mm / 0.32 x 2.36 x 2.36 inch	800 V/8 kV/3 ④; I <sub>n</sub> 10 A; 30 V, 10 A ⑤; 230 V, 10 A ⑥
	for (5 x 25) mm glass cartridge fuse; 15 ... 30 V	○ gray	281-612/281-541	50		
	for (5 x 25) mm glass cartridge fuse; 30 ... 65 V	○ gray	281-612/281-542	50		
	for (5 x 30) mm glass cartridge fuse; 15 ... 30 V	○ gray	281-622/281-541	50		
	for (5 x 30) mm glass cartridge fuse; 30 ... 65 V	○ gray	281-622/281-542	50		
	for 1/4" x 1" glass cartridge fuse; 15 ... 30 V	○ gray	281-613/281-541	50	10 x 60 x 60 mm / 0.39 x 2.36 x 2.36 inch	800 V/8 kV/3 ④; I <sub>n</sub> 10 A; 30 V, 10 A ⑤; 30 V, 10 A ⑥
	for 1/4" x 1" glass cartridge fuse; 30 ... 65 V	○ gray	281-613/281-542	50		
for 1/4" x 1 1/4" glass cartridge fuse; 15 ... 30 V	○ gray	281-623/281-541	50			
for 1/4" x 1 1/4" glass cartridge fuse; 30 ... 65 V	○ gray	281-623/281-542	50			
	Fused disconnect terminal block with a pivoting fuse holder; with blown fuse indication by neon lamp					
	for (5 x 20) mm glass cartridge fuse; 230 V	○ gray	281-611/281-417	50		
	for (5 x 20) mm glass cartridge fuse; 120 V	○ gray	281-611/281-418	50	8 x 60 x 60 mm / 0.32 x 2.36 x 2.36 inch	800 V/8 kV/3 ④; I <sub>n</sub> 10 A; 220 V, 10 A ⑤; 230 V, 10 A ⑥
	for (5 x 25) mm glass cartridge fuse; 230 V	○ gray	281-612/281-417	50		
	for (5 x 25) mm glass cartridge fuse; 120 V	○ gray	281-612/281-418	50		
	for (5 x 30) mm glass cartridge fuse; 230 V	○ gray	281-622/281-417	50		
	for (5 x 30) mm glass cartridge fuse; 120 V	○ gray	281-622/281-418	50		
	for 1/4" x 1" glass cartridge fuse; 230 V	○ gray	281-613/281-417	50	10 x 60 x 60 mm / 0.39 x 2.36 x 2.36 inch	800 V/8 kV/3 ④; I <sub>n</sub> 10 A; 220 V, 10 A ⑤; 100 V, 10 A ⑥
	for 1/4" x 1" glass cartridge fuse; 120 V	○ gray	281-613/281-418	50		
for 1/4" x 1 1/4" glass cartridge fuse; 230 V	○ gray	281-623/281-417	50			
for 1/4" x 1 1/4" glass cartridge fuse; 120 V	○ gray	281-623/281-418	50			
	2-conductor disconnect terminal block	○ gray ● orange	281-624 281-672	100 100	8 x 60 x 60 mm / 0.32 x 2.36 x 2.36 inch	800 V/8 kV/3 ④; I <sub>n</sub> 16 A; 600 V, 16 A ⑤
	End and intermediate plate	● orange ○ gray	281-309 281-311	25 25	2,5 x 55,3 x 60 mm / 0.1 x 2.18 x 2.36 inch	
<b>Fuse terminal block for mini-automotive blade-style fuses ②</b>						
	2-conductor fuse terminal block for automotive blade-style fuses; 12 V; with test point; with blown fuse indication by LED; LED power consumption: 4.8 mA					
	12 V; Circuit 1 ①	○ gray	282-698/281-429	25		
	12 V; Circuit 2 ②	○ gray	282-698/281-449	25	8 x 33,5 x 85 mm / 0.32 x 1.32 x 3.35 inch	400 V/6 kV/3 ④; I <sub>n</sub> 25 A; 30 A ⑤; 30 A ⑥
	24 V; Circuit 1 ①	○ gray	282-698/281-413	25		
24 V; Circuit 2 ②	○ gray	282-698/281-434	25			
	2-conductor fuse terminal block for automotive blade-style fuses; with test point; without blown fuse indication;	○ gray	282-696	25		400 V/6 kV/3 ④; I <sub>n</sub> 25 A; 600 V, 30 A ⑤; 24 V, 30 A ⑥
	End and intermediate plate	● orange ○ gray	282-334 282-333	25 25	2 x 26,1 x 80,5 mm / 0.08 x 1.03 x 3.33 inch	









① Conductor range: 0.08 ... 4 mm<sup>2</sup>; 28 ... 12 AWG;  
Strip length: 9 ... 10 mm / 0.35 ... 0.39 inch

② Conductor range: 0.2 ... 6 mm<sup>2</sup>; 24 ... 10 AWG;  
Strip length: 12 ... 13 mm / 0.47 ... 0.51 inch

③ Conductor range: 2.5 ... 16 mm<sup>2</sup>; 14 ... 6 AWG;  
Strip length: 12 ... 13 mm / 0.47 ... 0.51 inch  
Marking: WMB/WMB Inline/Marking strips

④ 400/800 V = rated voltage  
6 kV = rated impulse voltage  
3 = pollution degree

## WAGO Fuse Terminal Block; Fuse Plug 4/16 mm<sup>2</sup>; 281/811 Series

Image	Description	Color	Item No.	PU	Dimensions (W x H x D)	Electrical Data
<b>Fuse plug on carrier terminal block</b>						
	Fuse plug with pull-tab	○ gray				
	for (5 x 20) mm and (5 x 25) mm glass cartridge fuses	○ gray	281-511	50		
	for (5 x 20) mm and (5 x 25) mm glass cartridge fuses; with hole for one LED (for self-assembly)	○ gray	281-512	50		
	for (5 x 20) mm and (5 x 25) mm glass cartridge fuses; with LED, 24 VAC/DC	○ gray	281-512/281-501	50	Width: 6 mm / 0.24 inch	250 V; 6,3 A
	for (5 x 20) mm and (5 x 25) mm glass cartridge fuses; with 120 VAC/DC neon lamp	○ gray	281-512/281-418	50		
for (5 x 20) mm and (5 x 25) mm glass cartridge fuses; with 230 VAC/DC neon lamp	○ gray	281-512/281-417	50			
	2-conductor carrier terminal block; 0.08 ... 4 mm <sup>2</sup> / 28 ... 12 inch	○ gray	281-916	50	6 x 29 x 59 mm / 0.24 x 1.14 x 2.32 inch	400 V/6 kV/3 ④; I <sub>N</sub> 10 A
	End and intermediate plate; 2.5 mm thick	● orange	281-329	25	2,5 x 29 x 58,6 mm / 0.1 x 1.14 x 2.31 inch	
		○ gray	281-328	25		
	4-conductor carrier terminal block; 0.08 ... 4 mm <sup>2</sup> / 28 ... 12 inch	○ gray	281-656	50	6 x 29 x 86 mm / 0.24 x 1.14 x 3.39 inch	400 V/6 kV/3 ④; I <sub>N</sub> 10 A
	End and intermediate plate; 2.5 mm thick	● orange	281-335	25	2,5 x 29 x 86,2 mm / 0.1 x 1.14 x 3.4 inch	
		○ gray	281-334	25		
<b>Fuse terminal block for (10 x 38) mm (1 3/32" x 1 1/2") cylindrical fuses ③</b>						
	for photovoltaic applications; without blown fuse indication; 1-pole	○ gray	811-316	12	17,5 x 55 x 105 mm / 0.69 x 2.16 x 4.13 inch	1000 VDC; 32 A
	for photovoltaic applications; with blown fuse indication; 230 ... 1000 VDC; 1-pole	○ gray	811-317	12		
	without blown fuse indication; 1-pole	○ gray	811-310	12		
	without blown fuse indication; 2-pole	○ gray	811-320	6		690 VAC / 1000 VDC; 32 A ⑤; 600 VAC, 30 A ⑥; 750 VAC, 30 A ⑦; 1000 VDC, 30 A ⑧⑨
	without blown fuse indication; 3-pole	○ gray	811-330	4		
	with blown fuse indication; 90 ... 600 VAC; 115 ... 600 VDC; 1-pole	○ gray	811-311	12		
	with blown fuse indication; 90 ... 600 VAC; 115 ... 600 VDC; 2-pole	○ gray	811-321	6		
	with blown fuse indication; 90 ... 600 VAC; 115 ... 600 VDC; 3-pole	○ gray	811-331	4		
	with blown fuse indication; 24 VDC; 1-pole	○ gray	811-314	12		
<b>Fuse terminal block for class CC fuses ④</b>						
	without blown fuse indication; 1-pole	○ gray	811-410	12	17,5 x 55 x 105 mm / 0.69 x 2.16 x 4.13 inch	I <sub>N</sub> 32 A; 600 V, 30 A ⑤; 600 V, 30 A ⑥
	without blown fuse indication; 2-pole	○ gray	811-420	6		
	without blown fuse indication; 3-pole	○ gray	811-430	4		
	with blown fuse indication; 90 ... 600 VAC; 115 ... 600 VDC; 1-pole	○ gray	811-411	12		
	with blown fuse indication; 90 ... 600 VAC; 115 ... 600 VDC; 2-pole	○ gray	811-421	6		
	with blown fuse indication; 90 ... 600 VAC; 115 ... 600 VDC; 3-pole	○ gray	811-431	4		
	with blown fuse indication; 24 VDC; 1-pole	○ gray	811-414	12		
<b>Accessories for 811 Series</b>						
	Push-in type jumper bar; insulated; I <sub>N</sub> 63 A					
	2-way	gray	811-472	10		
	12-way	gray	811-482	10		

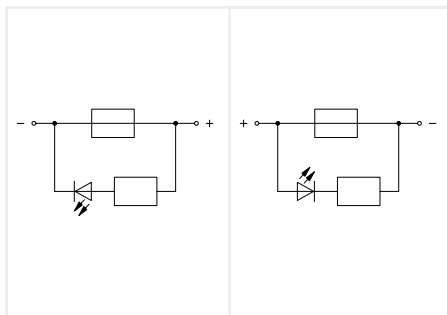











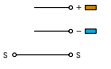

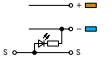



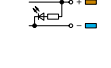

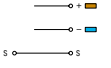

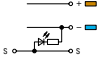



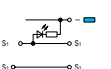

① Circuit 1

② Circuit 2

## WAGO Sensor terminal block

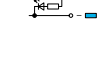
### 2.5 mm<sup>2</sup>; 280 Series

1

Image	Circuit Diagram	Description	Color	Item No.	PU	Dimensions (W x H x D)	Electrical Data
		Sensor terminal block	○ gray	280-560	50	5 x 55,5 x 80 mm / 0.2 x 2.19 x 3.15 inch	400 V/6 kV/3 ①; I <sub>N</sub> 20 A; 300 V, 15 A ②; 300 V, 15 A ③
		Sensor LED terminal block; for PNP (high-side) switching sensors; red LED; LED power consumption: 4.8 mA	○ gray	280-560/281-434	50		24 VDC; I <sub>N</sub> 20 A; 24 V, 15 A ②; 300 V, 15 A ③
		Sensor supply terminal block; power supply from sensor side	○ gray	280-564	10		400 V/6 kV/3 ①; I <sub>N</sub> 20 A; 300 V, 15 A ②; 300 V, 15 A ③
		Sensor LED supply terminal block; power supply from sensor side; for PNP (high-side) switching sensors; green LED; LED power consumption: 4.8 mA	○ gray	280-564/281-483	10		24 VDC; I <sub>N</sub> 20 A; 24 V, 15 A ②; 300 V, 15 A ③
		End and intermediate plate; 1 mm thick	● orange ○ gray	280-321 280-319	25 25	1 x 55,5 x 80 mm / 0.04 x 2.19 x 3.15 inch	
		Sensor terminal block; with ground connection	○ gray	280-570	50	5 x 63,5 x 90,5 mm / 0.2 x 2.5 x 3.56 inch	400 V/6 kV/3 ①; I <sub>N</sub> 20 A; 300 V, 15 A ②; 300 V, 15 A ③
		Sensor LED terminal block; for PNP (high-side) switching sensors; red LED; LED power consumption: 4.8 mA	○ gray	280-570/281-434	50		24 VDC; I <sub>N</sub> 20 A; 24 V, 15 A ②; 300 V, 15 A ③
		Sensor supply terminal block; with ground connection; power supply from sensor side	○ gray	280-574	10		400 V/6 kV/3 ①; I <sub>N</sub> 20 A; 300 V, 15 A ②; 300 V, 15 A ③
		Sensor LED supply terminal block; power supply from sensor side; for PNP (high-side) switching sensors; green LED; LED power consumption: 4.8 mA	○ gray	280-574/281-483	10		24 VDC; I <sub>N</sub> 20 A; 24 V, 15 A ②; 300 V, 15 A ③
		Sensor terminal block	○ gray	280-580	50	5 x 63,5 x 90,5 mm / 0.2 x 2.5 x 3.56 inch	400 V/6 kV/3 ①; I <sub>N</sub> 20 A; 300 V, 15 A ②; 300 V, 15 A ③
		Sensor LED terminal block; for PNP (high-side) switching sensors; red LED; LED power consumption: 4.8 mA	○ gray	280-580/281-434	50		24 VDC; I <sub>N</sub> 20 A; 24 V, 15 A ②;
		Sensor supply terminal block; power supply from sensor side	○ gray	280-584	10		400 V/6 kV/3 ①; I <sub>N</sub> 20 A; 300 V, 15 A ②; 300 V, 15 A ③
		Sensor LED supply terminal block; power supply from sensor side; for PNP (high-side) switching sensors; green LED; LED power consumption: 4.8 mA	○ gray	280-584/281-483	10		24 VDC; I <sub>N</sub> 20 A; 24 V, 15 A ②; 300 V, 15 A ③
		End and intermediate plate; 1 mm thick	● orange ○ gray	280-323 280-320	25 25	1 x 63,5 x 90 mm / 0.04 x 2.5 x 3.54 inch	
<b>Accessories for sensor/actuator terminal blocks</b>							
		Adjacent jumper; insulated; I <sub>N</sub> = I <sub>N</sub> terminal block	○ gray	280-402	25		
		Insulation stop; 5 pcs/strip					
		0.08 ... 0.2 mm <sup>2</sup> "s" (0.14 mm <sup>2</sup> "f-st")	white	280-470	25		
		0.25 ... 0.5 mm <sup>2</sup>	light gray	280-471	25		
		0.75 ... 1 mm <sup>2</sup>	dark gray	280-472	25		



## WAGO Actuator terminal block

### 2.5 mm<sup>2</sup>; 280 Series

Image	Circuit Diagram	Description	Color	Item No.	PU	Dimensions (W x H x D)	Electrical Data	
		Actuator terminal block	gray	280-562	50	5 x 55,5 x 80 mm / 0.2 x 2.19 x 3.15 inch	400 V/6 kV/3 ①; I <sub>N</sub> 20 A; 300 V, 15 A ②; 300 V, 15 A ③	
		Actuator terminal block; with 1N4007 recovery diode	gray	280-562/281-411	50		400 V/6 kV/3 ①; I <sub>N</sub> 20 A; 300 V, 15 A ②; 300 V, 15 A ③	
		Actuator LED terminal block; red LED; LED power consumption: 4.8 mA	gray	280-562/281-434	50		24 VDC; I <sub>N</sub> 20 A; 24 V, 15 A ②; 300 V, 15 A ③	
		Actuator LED terminal block; with 1N4007 recovery diode; red LED; LED power consumption: 4.8 mA	gray	280-562/281-420	50		24 VDC; I <sub>N</sub> 20 A; 24 V, 15 A ②; 300 V, 15 A ③	
		Actuator supply terminal block; power supply from actuator side	gray	280-592	10		400 V/6 kV/3 ①; I <sub>N</sub> 20 A; 300 V, 15 A ②; 300 V, 15 A ③	
		Actuator terminal block	gray	280-555	50		400 V/6 kV/3 ①; I <sub>N</sub> 20 A; 300 V, 15 A ②; 300 V, 15 A ③	
		Actuator supply terminal block; with 280-555: power supply from control side; with 280-554: power supply from actuator side	gray	280-556	20		400 V/6 kV/3 ①; I <sub>N</sub> 20 A; 300 V, 15 A ②; 300 V, 15 A ③	
		Actuator terminal block; with shield connection	gray	280-585	50		5 x 63,5 x 90,5 mm / 0.2 x 2.5 x 3.56 inch	400 V/6 kV/3 ①; I <sub>N</sub> 20 A; 300 V, 15 A ②; 300 V, 15 A ③
		Actuator supply terminal block; with shield connection; power supply from control panel side	gray	280-586	50			400 V/6 kV/3 ①; I <sub>N</sub> 20 A; 300 V, 15 A ②; 300 V, 15 A ③
		End and intermediate plate; 1 mm thick	orange gray	280-321 280-319	25 25		1 x 55,5 x 80 mm / 0.04 x 2.19 x 3.15 inch	
		Actuator terminal block; with ground connection	gray	280-572	50	5 x 63,5 x 90,5 mm / 0.2 x 2.5 x 3.56 inch	400 V/6 kV/3 ①; I <sub>N</sub> 20 A; 300 V, 15 A ②; 300 V, 15 A ③	
		Actuator terminal block; with ground connection; with 1N4007 recovery diode	gray	280-572/281-411	50		400 V/6 kV/3 ①; I <sub>N</sub> 20 A; 300 V, 15 A ②; 300 V, 15 A ③	
		Actuator LED terminal block; with ground connection; red LED; LED power consumption: 4.8 mA	gray	280-572/281-434	50		24 VDC; I <sub>N</sub> 20 A; 24 V, 15 A ②; 300 V, 15 A ③	
		Actuator LED terminal block; with ground connection; with 1N4007 recovery diode; red LED; LED power consumption: 4.8 mA	gray	280-572/281-420	50		24 VDC; I <sub>N</sub> 20 A; 24 V, 15 A ②; 300 V, 15 A ③	
		Actuator supply terminal block; with ground connection; power supply from actuator side	gray	280-593	10		400 V/6 kV/3 ①; I <sub>N</sub> 20 A; 300 V, 15 A ②; 300 V, 15 A ③	
		End and intermediate plate; 1 mm thick	orange gray	280-323 280-320	25 25		1 x 63,5 x 90 mm / 0.04 x 2.5 x 3.54 inch	

Conductor range: 0.08 ... 2.5 mm<sup>2</sup>; 28 ... 12 AWG;  
Strip length: 8 ... 9 mm / 0.31 ... 0.35 inch

① 400 V = rated voltage  
6 kV = rated impulse voltage  
3 = pollution degree

Marking: WMB/WMB Inline/Marking strips

## WAGO X-COM®-SYSTEM Operation

2

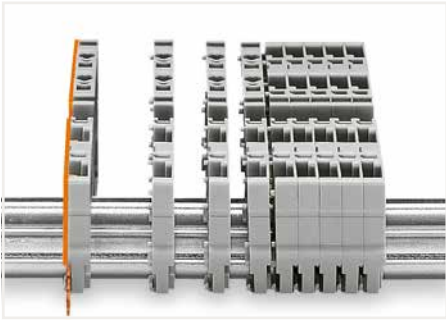

Snap individual carrier terminal blocks onto the DIN-rail and slide together.

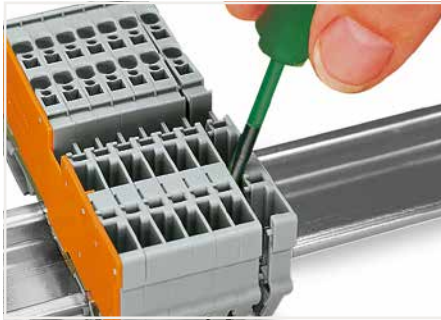

Open the assembly by laterally sliding a block via operating tool and remove terminal block via release lever.



Carrier terminal block: Insert/remove conductor via operating tool (3.5 x 0.5 mm blade).



Coding a female plug by removing coding finger(s) via cutting tool. Do not remove the first and last coding fingers or use an additional locking lever.

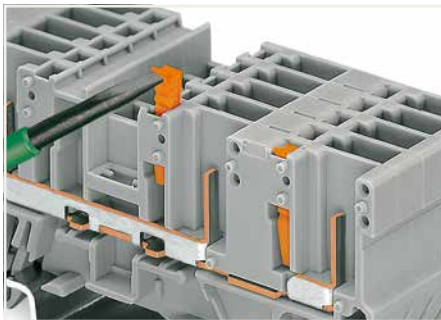

Snap coding pin in proper direction on carrier terminal block.  
Shown: Coding pin removal from carrier terminal block.

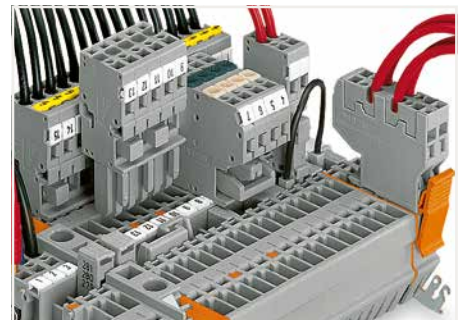

Commoning with adjacent or staggered jumpers – push jumpers down until fully inserted.



Commoning carrier terminal blocks via staggered jumpers.

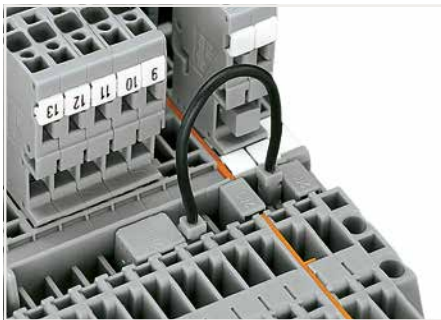

Commoning carrier terminal blocks via push-in type wire jumpers or adjacent jumpers – even over an intermediate plate.

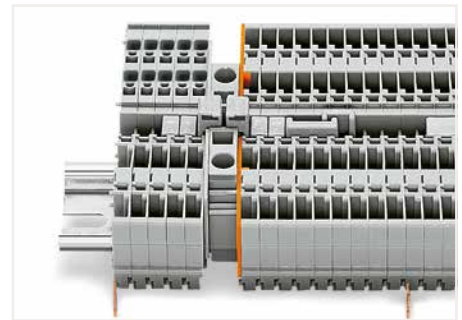

Commoning "supply terminal blocks" (up to 10 mm<sup>2</sup>/8 AWG) with carrier terminal blocks via step-down jumpers.

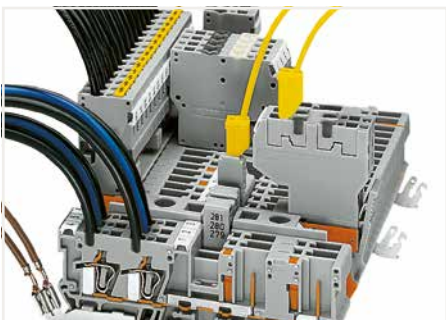

Testing with a 2.3 mm Ø test plug (max. 42 V).













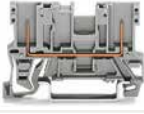

Removing a female plug via conductor bundle provided with strain relief plate.



Commoning a 1-conductor female plug via miniature adjacent jumpers.

## WAGO Carrier Terminal Block; X-COM®-SYSTEM – 769 Series

### 4 mm<sup>2</sup>

Image	Description	Color	Item No.	PU	Dimensions (W x H x D)	Electrical Data
<b>1-conductor/1-pin carrier terminal block</b>						
	1-conductor/1-pin carrier terminal block	○ gray	769-176	100	5 x 28,5 x 52,5 mm / 0.2 x 1.12 x 2.07 inch	500 V/6 kV/3 ①; I <sub>n</sub> 32 A; 300 V, 20 A ②; 300 V, 20 A ③
	1-conductor/1-pin carrier terminal block	● blue	769-176/000-006	100		
	1-conductor/1-pin carrier terminal block	● orange	769-176/000-012	100		
	1-conductor/1-pin ground carrier terminal block	● green-yellow	769-237	100		
	1-conductor/1-pin carrier terminal block; with shield contact	○ gray	769-231	50		
	End and intermediate plate; 1.1 mm thick	● orange	769-308	25	1,1 x 24,1 x 52,5 mm /	
		○ gray	769-307	25	0.04 x 0.95 x 2.07 inch	
<b>2-pin carrier terminal block</b>						
	2-pin carrier terminal block	○ gray	769-156	100	5 x 28,5 x 52,5 mm / 0.2 x 1.12 x 2.07 inch	500 V/6 kV/3 ①; I <sub>n</sub> 32 A; 300 V, 20 A ②; 300 V, 20 A ③
	2-pin ground carrier terminal block	● green-yellow	769-227	100		
	2-pin carrier terminal block; with shield contact	○ gray	769-221	50		
	End and intermediate plate; 1.1 mm thick	● orange	769-306	25	1,1 x 24,1 x 52,5 mm /	
		○ gray	769-305	25	0.04 x 0.95 x 2.07 inch	
<b>2-conductor/2-pin carrier terminal block</b>						
	2-conductor/2-pin carrier terminal block	○ gray	769-171	50	5 x 28,5 x 87,5 mm / 0.2 x 1.12 x 3.44 inch	500 V/6 kV/3 ①; I <sub>n</sub> 32 A; 300 V, 20 A ②; 300 V, 20 A ③
	2-conductor/2-pin carrier terminal block	● blue	769-171/000-006	50		
	2-conductor/2-pin ground carrier terminal block	● green-yellow	769-217	50		
	2-conductor/2-pin carrier terminal block; with shield contact	○ gray	769-211	50		
	End and intermediate plate; 1.1 mm thick	● orange	769-304	25	1,1 x 24,1 x 87,2 mm /	
		○ gray	769-303	25	0.04 x 0.95 x 3.43 inch	
<b>4-pin carrier terminal block</b>						
	4-pin carrier terminal block	○ gray	769-151	50	5 x 28,5 x 87,5 mm / 0.2 x 1.12 x 3.44 inch	500 V/6 kV/3 ①; I <sub>n</sub> 32 A; 300 V, 20 A ②; 300 V, 20 A ③
	4-pin ground carrier terminal block	● green-yellow	769-207	50		
	4-pin carrier terminal block; with shield contact	○ gray	769-201	50		
	End and intermediate plate; 1.1 mm thick	● orange	769-302	25	1,1 x 24,1 x 87,2 mm /	
		○ gray	769-301	25	0.04 x 0.95 x 3.43 inch	
<b>2-conductor/1-pin carrier terminal block</b>						
	2-conductor/1-pin carrier terminal block	○ gray	769-251	50	5 x 28,5 x 69 mm / 0.2 x 1.12 x 2.72 inch	500 V/6 kV/3 ①; I <sub>n</sub> 32 A; 300 V, 20 A ②; 300 V, 20 A ③
	2-conductor/1-pin carrier terminal block	● blue	769-251/000-006	50		
	2-conductor/1-pin ground carrier terminal block	● green-yellow	769-257	50		
	End and intermediate plate; 1.1 mm thick	● orange	769-321	25	1,1 x 24,1 x 69 mm /	
		○ gray	769-320	25	0.04 x 0.95 x 2.72 inch	
<b>1-conductor/1-pin carrier terminal block; with three jumper positions</b>						
	1-conductor/1-pin carrier terminal block; with three jumper positions	○ gray	769-214	50	5 x 28,5 x 87,5 mm / 0.2 x 1.12 x 3.44 inch	500 V/6 kV/3 ①; I <sub>n</sub> 32 A; 300 V, 20 A ②; 300 V, 20 A ③
		○ gray	769-214	50		
	End and intermediate plate; 1.1 mm thick	● orange	769-316	25	1,1 x 24,1 x 87,2 mm /	
		○ gray	769-315	25	0.04 x 0.95 x 3.43 inch	









Conductor range: 0.08 ... 4 mm<sup>2</sup>; 28 ... 12 AWG;  
Strip length: 8 ... 9 mm / 0.31 ... 0.35 inch

① 500 V = rated voltage  
6 kV = rated impulse voltage  
3 = pollution degree

Marking: WMB/WMB Inline/Marking strips

## WAGO Disconnect Carrier Terminal Block; X-COM®-SYSTEM – 769 Series

4 mm<sup>2</sup>

Image	Description	Color	Item No.	PU	Dimensions (W x H x D)	Electrical Data
<b>1-conductor/1-pin disconnect carrier terminal block</b>						
	1-conductor/1-pin disconnect carrier terminal block	○ gray	769-232	50	5 x 28,5 x 52,5 mm / 0.2 x 1.12 x 2.07 inch	400 V/6 kV/3 ①; I <sub>N</sub> 16 A; 300 V, 20 A ②; 300 V, 20 A ③
	1-conductor/1-pin disconnect carrier terminal block; with shield contact	○ gray	769-233	50		
	End and intermediate plate; 1.1 mm thick	● orange	769-308	25	1,1 x 24,1 x 52,5 mm / 0.04 x 0.95 x 2.07 inch	
		○ gray	769-307	25		
<b>2-pin disconnect carrier terminal block</b>						
	2-pin disconnect carrier terminal block	○ gray	769-222	50	5 x 28,5 x 52,5 mm / 0.2 x 1.12 x 2.07 inch	400 V/6 kV/3 ①; I <sub>N</sub> 16 A; 300 V, 20 A ②; 300 V, 20 A ③
	2-pin disconnect carrier terminal block; with shield contact	○ gray	769-223	50		
	End and intermediate plate; 1.1 mm thick	● orange	769-306	25	1,1 x 24,1 x 52,5 mm / 0.04 x 0.95 x 2.07 inch	
		○ gray	769-305	25		
<b>1-conductor/1-pin disconnect carrier terminal block; with two jumper positions</b>						
	1-conductor/1-pin disconnect carrier terminal block; with two jumper positions	○ gray	769-212	50	5 x 28,5 x 87,5 mm / 0.2 x 1.12 x 3.44 inch	400 V/6 kV/3 ①; I <sub>N</sub> 16 A; 300 V, 20 A ②; 300 V, 20 A ③
	1-conductor/1-pin disconnect carrier terminal block; with shield contact; with two jumper positions	○ gray	769-213	50		
	End and intermediate plate; 1.1 mm thick	● orange	769-312	25	1,1 x 24,1 x 87,2 mm / 0.04 x 0.95 x 3.43 inch	
		○ gray	769-311	25		
<b>2-pin disconnect carrier terminal block; with two jumper positions</b>						
	2-pin disconnect carrier terminal block; with two jumper positions	○ gray	769-202	50	5 x 28,5 x 87,5 mm / 0.2 x 1.12 x 3.44 inch	400 V/6 kV/3 ①; I <sub>N</sub> 16 A; 300 V, 20 A ②; 300 V, 20 A ③
	2-pin disconnect carrier terminal block; with shield contact; with two jumper positions	○ gray	769-203	50		
	End and intermediate plate; 1.1 mm thick	● orange	769-310	25	1,1 x 24,1 x 87,2 mm / 0.04 x 0.95 x 3.43 inch	
		○ gray	769-309	25		



1-conductor female plug

Disconnect carrier terminal blocks can be commoned via 280 and 780 Series Jumpers and tested using a test plug adapter (280-4..).



2-conductor female plug

Diode carrier terminal blocks can be commoned via 280 and 780 Series Jumpers and tested using a test plug adapter (280-4..).



2-conductor and 1-conductor female plugs (may be reversed)

LED carrier terminal blocks can be commoned via 280 and 780 Series Jumpers and tested using a test plug adapter (280-4..).

Conductor range: 0.08 ... 4 mm<sup>2</sup>; 28 ... 12 AWG;  
Strip length: 8 ... 9 mm / 0.31 ... 0.35 inch

① 400 V = rated voltage  
6 kV = rated impulse voltage  
3 = pollution degree

Marking: WMB/WMB Inline/Marking strips

## WAGO Diode Carrier Terminal Block; LED Carrier Terminal Block; X-COM®-SYSTEM – 769 Series 4 mm<sup>2</sup>

Image	Description	Color	Item No.	PU	Dimensions (W x H x D)	Electrical Data
<b>1-conductor/1-pin diode/LED carrier terminal block</b>						
	1-conductor/1-pin diode carrier terminal block; right-side anode	○ gray	769-238/281-411	100	5 x 28,5 x 52,5 mm / 0.2 x 1.12 x 2.07 inch	U <sub>N</sub> 250 V; U <sub>RM</sub> 1000 V; 1N4007 – 0.5 A continuous current
	1-conductor/1-pin diode carrier terminal block; left-side anode	○ gray	769-238/281-410	100		
	1-conductor/1-pin LED carrier terminal block; right-side anode	○ gray	769-239/281-413	100	5 x 28,5 x 52,5 mm / 0.2 x 1.12 x 2.07 inch	24 VDC; I <sub>F</sub> 0.025 A (max.)
	1-conductor/1-pin LED carrier terminal block; left-side anode	○ gray	769-239/281-434	100		
	End and intermediate plate; 1.1 mm thick	● orange	769-308	25	1,1 x 24,1 x 52,5 mm / 0.04 x 0.95 x 2.07 inch	
		○ gray	769-307	25		
<b>2-pin diode/LED carrier terminal block</b>						
	2-pin diode carrier terminal block; right-side anode	○ gray	769-228/281-411	100	5 x 28,5 x 52,5 mm / 0.2 x 1.12 x 2.07 inch	U <sub>N</sub> 250 V; U <sub>RM</sub> 1000 V; 1N4007 – 0.5 A continuous current
	2-pin diode carrier terminal block; left-side anode	○ gray	769-228/281-410	100		
	2-pin LED carrier terminal block; right-side anode	○ gray	769-229/281-413	100	5 x 28,5 x 52,5 mm / 0.2 x 1.12 x 2.07 inch	24 VDC; I <sub>F</sub> 0.025 A (max.)
	2-pin LED carrier terminal block; left-side anode	○ gray	769-229/281-434	100		
	End and intermediate plate; 1.1 mm thick	● orange	769-306	25	1,1 x 24,1 x 52,5 mm / 0.04 x 0.95 x 2.07 inch	
		○ gray	769-305	25		
<b>1-conductor/1-pin diode/LED carrier terminal block; with two jumper positions</b>						
	1-conductor/1-pin diode carrier terminal block; with two jumper positions; right-side anode	○ gray	769-218/281-411	50	5 x 28,5 x 87,5 mm / 0.2 x 1.12 x 3.44 inch	U <sub>N</sub> 250 V; U <sub>RM</sub> 1000 V; 1N4007 – 0.5 A continuous current
	1-conductor/1-pin diode carrier terminal block; with two jumper positions; right-side anode	○ gray	769-218/281-410	50		
	1-conductor/1-pin LED carrier terminal block; with two jumper positions; right-side anode	○ gray	769-219/281-413	50	5 x 28,5 x 87,5 mm / 0.2 x 1.12 x 3.44 inch	24 VDC; I <sub>F</sub> 0.025 A (max.)
	1-conductor/1-pin LED carrier terminal block; with two jumper positions; right-side anode	○ gray	769-219/281-434	50		
	End and intermediate plate; 1.1 mm thick	● orange	769-312	25	1,1 x 24,1 x 87,2 mm / 0.04 x 0.95 x 3.43 inch	
		○ gray	769-311	25		
<b>2-pin diode/LED carrier terminal block; with two jumper positions</b>						
	2-pin diode carrier terminal block; with two jumper positions; right-side anode	○ gray	769-208/281-411	50	5 x 28,5 x 87,5 mm / 0.2 x 1.12 x 3.44 inch	U <sub>N</sub> 250 V; U <sub>RM</sub> 1000 V; 1N4007 – 0.5 A continuous current
	2-pin diode carrier terminal block; with two jumper positions; left-side anode	○ gray	769-208/281-410	50		
	2-pin LED carrier terminal block; with two jumper positions; right-side anode	○ gray	769-209/281-413	50	5 x 28,5 x 87,5 mm / 0.2 x 1.12 x 3.44 inch	24 VDC; I <sub>F</sub> 0.025 A (max.)
	2-pin LED carrier terminal block; with two jumper positions; left-side anode	○ gray	769-209/281-434	50		
	End and intermediate plate; 1.1 mm thick	● orange	769-310	25	1,1 x 24,1 x 87,2 mm / 0.04 x 0.95 x 3.43 inch	
		○ gray	769-309	25		

Conductor range: 0.08 ... 4 mm<sup>2</sup>; 28 ... 12 AWG;  
Strip length: 8 ... 9 mm / 0.31 ... 0.35 inch

Marking: WMB/WMB Inline/Marking strips

## WAGO Double-Deck Carrier Terminal Block; X-COM®-SYSTEM – 870 Series

### 2,5 mm<sup>2</sup>

Image	Description	Color	Item No.	PU	Potential Marking	Electrical Data
<b>1-conductor/1-pin double-deck carrier terminal block ①</b>						
	1-conductor/1-pin double-deck carrier terminal block; Through/through terminal block	○ gray	<b>870-101</b>	50	L/L	500 V/6 kV/3 ⑤; I <sub>N</sub> 16 A; 300 V, 20 A ⑧
	1-conductor/1-pin double-deck carrier terminal block; Ground conductor/through terminal block	○ gray	<b>870-102</b>	50	N/L	
		○ gray	<b>870-103</b>	50	L/N	
		● blue	<b>870-104</b>	50	N/N	
		○ gray	<b>870-117</b>	50	GND/N	
		○ gray	<b>870-127</b>	50	GND/L	
	End and intermediate plate; 1 mm thick	● orange	<b>870-119</b>	25		
		○ gray	<b>870-118</b>	25		
<b>2-pin/2-pin double-deck carrier terminal block ②</b>						
	2-conductor/1-pin double-deck carrier terminal block; Through/through terminal block	○ gray	<b>870-1131</b>	40	L/L	500 V/6 kV/3 ⑤; I <sub>N</sub> 16 A; 300 V, 20 A ⑧
	4-conductor/2-pin double-deck carrier block; 4-conductor/2-pin ground conductor block; internally commoned	● green-yellow	<b>870-1137</b>	40	GND/N	
	4-conductor/2-pin carrier terminal block; 2-conductor/2-pin through terminal block; internally commoned; violet conductor entry	○ gray	<b>870-1138</b>	40	L	
	End and intermediate plate; 1 mm thick	● orange	<b>870-1149</b>	25		
		○ gray	<b>870-1148</b>	25		
<b>2-pin/2-pin double-deck carrier terminal block ③</b>						
	2-pin/2-pin double-deck carrier terminal block; Through/through terminal block	○ gray	<b>870-151</b>	50	L/L	500 V/6 kV/3 ⑤; I <sub>N</sub> 16 A
	4-pin double-deck carrier terminal block; Ground conductor/through terminal block	● green-yellow	<b>870-157</b>	50	GND	
	4-pin double-deck carrier terminal block; 4-pin through terminal block; internally commoned; violet conductor entry	○ gray	<b>870-158</b>	50	L	
	End and intermediate plate; 1 mm thick	● orange	<b>870-169</b>	25		
		○ gray	<b>870-168</b>	25		
<b>2-conductor/2-pin double-deck carrier terminal block ④</b>						
	2-conductor/2-pin double-deck carrier terminal block; Through/through terminal block	○ gray	<b>870-131</b>	40	L/L	500 V/6 kV/3 ⑤; I <sub>N</sub> 16 A
	4-conductor/4-pin double-deck carrier block; 4-conductor/4-pin ground conductor block; internally commoned	● green-yellow	<b>870-137</b>	40	GND	
	4-conductor/4-pin double-deck carrier terminal block; 4-conductor/4-pin through terminal block; internally commoned; violet conductor entry	○ gray	<b>870-138</b>	40	L	
	End and intermediate plate; 1 mm thick	● orange	<b>870-149</b>	25		
		○ gray	<b>870-148</b>	25		



1-conductor female plug; angled  
Double-deck carrier terminal blocks can be commoned via 870 Series Push-In Type Jumper Bars.



1-connector female plug; straight  
Double-deck carrier terminal blocks can be commoned via 870 Series Push-In Type Jumper Bars.

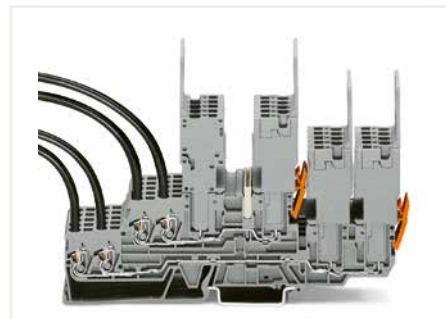

1-connector female plug; straight  
Double-deck carrier terminal blocks can be commoned via 870 Series Push-In Type Jumper Bars.

① Dimensions (W x H x D):  
5 x 40 x 70 mm / 0.2 x 1.57 x 2.76 inch;  
Conductor range: 0.08 ... 2.5 mm<sup>2</sup> / 28 ... 16 AWG;  
Strip length: 6 ... 7 mm / 0.24 ... 0.28 inch

④ Dimensions (W x H x D):  
5 x 37.1 x 132.7 mm / 0.2 x 1.46 x 5.22 inch;  
Conductor range: 0.08 ... 2.5 mm<sup>2</sup> / 28 ... 12 AWG;  
Strip length: 6 ... 7 mm / 0.24 ... 0.28 inch

② Dimensions (W x H x D):  
5 x 39.8 x 91 mm / 0.2 x 1.57 x 3.58 inch;  
Conductor range: 0.08 ... 2.5 mm<sup>2</sup> / 28 ... 12 AWG;  
Strip length: 6 ... 7 mm / 0.24 ... 0.28 inch











⑤ 500/500 V = rated voltage;  
6 kV = rated impulse voltage;  
3 = pollution degree

③ Dimensions (W x H x D):  
5 x 37.1 x 88.6 mm / 0.2 x 1.46 x 3.49 inch

Marking: WMB/WMB Inline/Marking strips

## WAGO Female Plug; X-COM®-SYSTEM – 769 Series

### 4 mm<sup>2</sup>

Image	Description	Color	Item No.	PU	Dimensions (W x H x D)	Electrical Data
<b>1-conductor female plug</b>						
	1-conductor female plug; straight; fits into carrier terminal blocks; codable; can be commoned with miniature adjacent jumpers					
	1-pole	○ gray	769-101	200	(5 x pole no.) x 45.2 x 18.3 mm / (0.2 x pole no.) x 1.78 x 0.72 inch	500 V/6 kV/3 ①; I <sub>n</sub> 32 A; 300 V, 20 A ②; 300 V, 20 A ③
	2-pole	○ gray	769-102	100		
	3-pole	○ gray	769-103	50		
	...		...			
15-pole	○ gray	769-115	10			
	1-conductor female plug; angled; fits into carrier terminal blocks; codable					
	1-pole	○ gray	769-101/022-000	200	(5 x pole no.) x 37.1 x 26.5 mm / (0.2 x pole no.) x 1.46 x 1.04 inch	500 V/6 kV/3 ①; I <sub>n</sub> 32 A; 300 V, 20 A ②; 300 V, 20 A ③
	2-pole	○ gray	769-102/022-000	100		
	3-pole	○ gray	769-103/022-000	50		
	...		...			
15-pole	○ gray	769-115/022-000	10			
<b>2-conductor female plug</b>						
	2-conductor female plug; fits into carrier terminal blocks; codable; can be commoned with adjacent and staggered jumpers					
	1-pole	○ gray	769-121	100	(5 x pole no.) x 45.2 x 35.9 mm / (0.2 x pole no.) x 1.78 x 1.41 inch	500 V/6 kV/3 ①; I <sub>n</sub> 32 A; 300 V, 20 A ②; 300 V, 20 A ③
	2-pole	○ gray	769-122	50		
	3-pole	○ gray	769-123	25		
	...		...			
15-pole	○ gray	769-135	5			
<b>Accessories for female plugs</b>						
	Locking lever; for 1-pole female plugs	○ gray	769-428	25		
	Locking lever; for 1-pole female plugs	● orange	769-429	25		
	Locking lever; for female plugs with 2 poles and more	● orange	769-431	25		
	Locking lever; for female plugs with 2 poles and more	○ gray	769-430	25		
	Strain relief plate; 1-pole	○ gray	769-410	25		
	Strain relief plate; 2- ... 3-pole	○ gray	769-411	25		
	Strain relief plate; 4- ... 5-pole	○ gray	769-412	25		
	Strain relief plate; 6- ... 9-pole	○ gray	769-413	25		
	Strain relief plate; 10- ... 15-pole	○ gray	769-414	25		
	Snap-on type strain relief housing; consists of strain relief support and housing; only suitable for cable ties					
	2-pole	○ gray	769-1602	100		
	...		...			
	Snap-on type strain relief housing; consists of strain relief support and housing					
	2-pole	○ gray	769-1606	100		
	...		...			
	15-pole	○ gray	769-1615	25		
	Coding pin; for coding female plugs	● orange	769-435	25		
	Insulation stop; 5 pcs/strip					
	0.08 ... 0.2 mm <sup>2</sup>	○ white	769-470	25		
	0.25 ... 0.5 mm <sup>2</sup>	○ light gray	769-471	25		
	0.75 ... 1 mm <sup>2</sup>	● dark gray	769-472	25		

Conductor range: 0.08 ... 2.5 mm<sup>2</sup>; 28 ... 12 AWG;  
Strip length: 8 ... 9 mm / 0.31 ... 0.35 inch

① 500 V = rated voltage  
6 kV = rated impulse voltage  
3 = pollution degree

Marking: WMB/WMB Inline/Marking strips

## Series-Specific Accessories for WAGO Classic Rail-Mount Terminal Block and X-COM® Selection Guide

Illustration	Description	279 Series	PU	280 Series 769 Series	PU	281 Series	PU	282 Series	PU	284 Series	PU	283 Series	PU
	Adjacent jumper; insulated; I <sub>N</sub> = I <sub>N</sub> terminal block	<input type="radio"/> 279-402	25	<input type="radio"/> 280-402	25	<input type="radio"/> 281-402	25	<input type="radio"/> 282-402	25	<input type="radio"/> 284-402	25	<input type="radio"/> 283-402	25
		<input checked="" type="radio"/> 279-422	25	<input checked="" type="radio"/> 280-422	25	<input checked="" type="radio"/> 281-422	25	<input checked="" type="radio"/> 282-422	25	<input checked="" type="radio"/> 284-422	25	<input checked="" type="radio"/> 283-422	25
	Double adjust jumper; insulated; I <sub>N</sub> = I <sub>N</sub> of terminal block	<input type="radio"/> 279-409	25	<input type="radio"/> 280-409	25	<input type="radio"/> 281-409	25	<input type="radio"/> 282-409	25	<input type="radio"/> 284-409	25	<input type="radio"/> 283-409	25
	Staggered jumper; I <sub>N</sub> = I <sub>N</sub> of terminal block												
	1 to 2			<input type="radio"/> 780-452	25	<input type="radio"/> 781-452	25						
	1 to 3			<input type="radio"/> 780-453	25	<input type="radio"/> 781-453	25						
	1 to 4			<input type="radio"/> 780-454	25	<input type="radio"/> 781-454	25						
	1 to 5			<input type="radio"/> 780-455	25	<input type="radio"/> 781-455	25						
	1 to 6			<input type="radio"/> 780-456	25	<input type="radio"/> 781-456	25						
	1 to 7			<input type="radio"/> 780-457	25								
	1 to 8			<input type="radio"/> 780-458	25								
	Vertical jumper			<input type="radio"/> 281-421	25	<input type="radio"/> 281-421	25						
	Comb-style jumper bar; insulated; I <sub>N</sub> = I <sub>N</sub> of terminal block												
	2-way	<input type="radio"/> 279-482	25	<input type="radio"/> 280-482	25	<input type="radio"/> 281-482	25						
	3-way	<input type="radio"/> 279-483	25	<input type="radio"/> 280-483	25	<input type="radio"/> 281-483	25						
	5-way					<input type="radio"/> 281-485	25						
	10-way	<input type="radio"/> 279-490	25	<input type="radio"/> 280-490	25	<input type="radio"/> 281-490	25						
	Alternate comb-style jumper bar; insulated; I <sub>N</sub> = I <sub>N</sub> of terminal block	<input type="radio"/> 279-492	25	<input type="radio"/> 280-492	25	<input type="radio"/> 281-492	25						
	Push-in type wire jumper; I <sub>N</sub> 30 A												
	L = 60 mm	<input checked="" type="radio"/> 249-125	10	<input checked="" type="radio"/> 249-125	10	<input checked="" type="radio"/> 249-125	10						
	L = 110 mm	<input checked="" type="radio"/> 249-126	10	<input checked="" type="radio"/> 249-126	10	<input checked="" type="radio"/> 249-126	10						
	L = 250 mm	<input checked="" type="radio"/> 249-127	10	<input checked="" type="radio"/> 249-127	10	<input checked="" type="radio"/> 249-127	10						
	Insulation stop	<input type="radio"/> 279-470	25	<input type="radio"/> 280-470	25	<input type="radio"/> 281-470	25						
		<input checked="" type="radio"/> 279-471	25	<input type="radio"/> 280-471	25	<input type="radio"/> 281-471	25						
				<input checked="" type="radio"/> 280-472	25	<input checked="" type="radio"/> 281-472	25						
	Protective warning marker	<input checked="" type="radio"/> 279-415	25	<input checked="" type="radio"/> 280-415	25	<input checked="" type="radio"/> 281-415	25	<input checked="" type="radio"/> 281-415	25	<input checked="" type="radio"/> 284-415	25	<input checked="" type="radio"/> 283-415	25
	Finger guard									<input checked="" type="radio"/> 284-400	25	<input checked="" type="radio"/> 283-400	25
	Test plug module			<input type="radio"/> 280-418	25	<input type="radio"/> 281-418	25	<input type="radio"/> 709-310	25	<input type="radio"/> 709-310	25		
	Spacer module			<input type="radio"/> 280-419	25	<input type="radio"/> 281-419	25	<input type="radio"/> 709-311	25				
	Test plug adapter												
	2.3 mm	<input type="radio"/> 280-404	25	<input type="radio"/> 280-404	25	<input type="radio"/> 280-404	25						
	4 mm	<input type="radio"/> 209-170	25	<input type="radio"/> 209-170	25	<input type="radio"/> 209-170	25	<input type="radio"/> 209-170	25	<input type="radio"/> 209-170	25	<input type="radio"/> 209-170	25
	Test plug with CAGE CLAMP®			<input type="radio"/> 281-407	25	<input type="radio"/> 281-407	25						

I<sub>N</sub> = I<sub>N</sub> terminal block



## Series-Specific Accessories for WAGO Classic Rail-Mount Terminal Block Handling

2

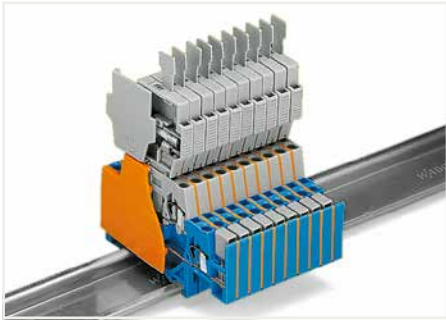

When double-deck terminal blocks are used with a fuse plug (6 mm wide) in the receptacle (top) level, the extra width of the 280 Series (5 mm wide) can be compensated for via intermediate plates (1.1 mm thick). If required, this special intermediate plate still allows commoning on the lower level via push-in adjacent jumpers (280-402).

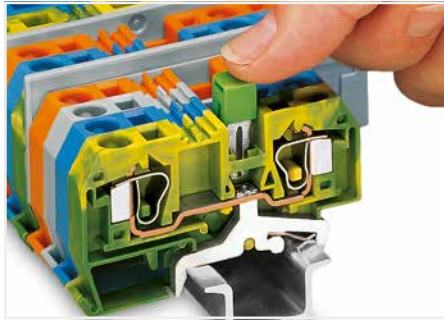

Commoning ground conductor terminal blocks through terminal blocks is possible in one direction only (via rear side of terminal block) using adjacent jumpers. WAGO recommends using yellow-green adjacent jumpers in addition to the required marking of these blocks.

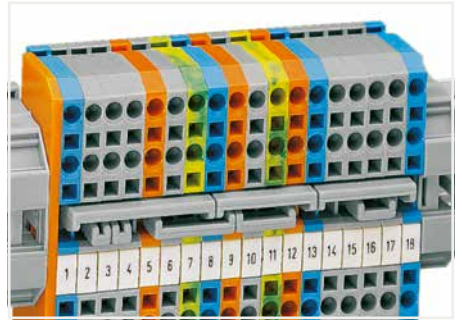

Staggered jumpers are suitable for sophisticated circuit requirements – push jumpers down until fully inserted.

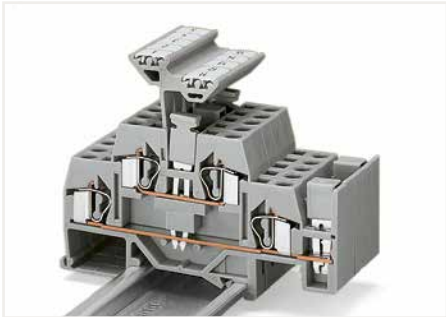

A vertical jumper commons the upper and lower decks, creating a 4-conductor commoned through terminal block in one housing. Two adjacent terminals may be commoned together on the same deck using a push-in adjacent jumper.



Commoning front-entry disconnect terminal blocks via comb-style jumper bar using a 10-pole operating tool

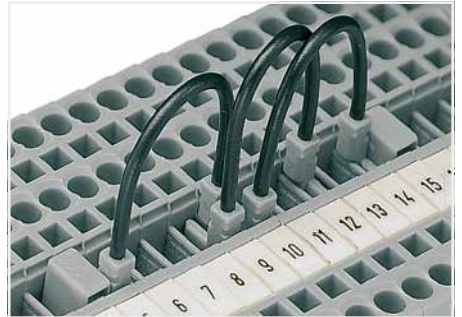

The 280/775/780 and 281/776/777/781 Series Terminal Blocks accept two wire jumpers, allowing the use of commoning chains. Furthermore, the 280/769/775/780/880 and 281/776/777/781 Series allow both a wire jumper and an adjacent jumper to be simultaneously plugged into a same terminal block.

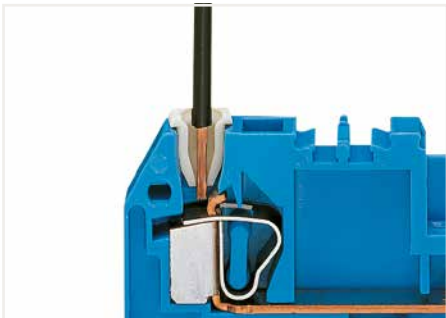

The insulation stop bundles the conductor during connection to the clamping unit.

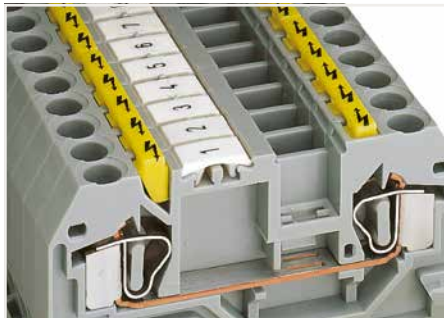

Protective warning markers inserted into the operating slots



Finger guard seals an unused conductor entry.

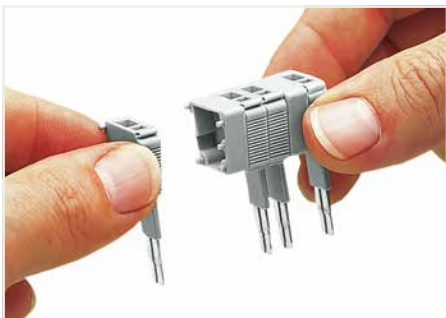

Snapping test plug and spacer modules together to assemble a multipole test plug module (max. 10 poles)

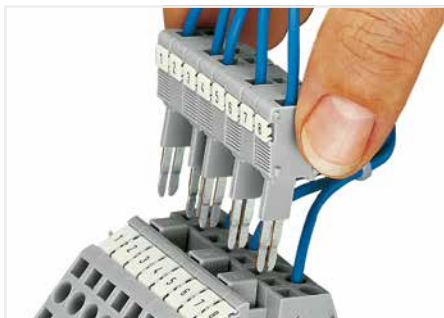

Testing in the jumper slot



Testing with a test plug  
Picture shows a test plug adapter (209-170)

# WAGO Matrix Patchboard; WAGO Common Potential Matrix Patchboard

## - 726 Series

### 1.5 / 2.5 / 16 mm<sup>2</sup>

3

Illustration	Description	Color	Item No.	PU	Marking	Electrical Data
<b>Matrix patchboard; 32-pole</b>						
	Matrix patchboard; dark gray modules; vertical module marking on sides 1 and 2; 32-pole	○ white/gray	726-121 ①	20	1 ... 32	500 V/6 kV/3 ④; I <sub>N</sub> 10 A; 300 V, 10 A ⑤; 300 V, 10 A ⑥
		○ white/gray	726-122 ①	20	33 ... 64	
	Matrix patchboard; dark gray modules; vertical module marking on sides 1 and 2; 32-pole	○ white/gray	726-221 ②	20	1 ... 32	
		○ white/gray	726-222 ②	20	33 ... 64	
	Matrix patchboard; dark gray modules; vertical module marking on sides 1 and 2; for 19" racks; 32-pole	○ white/gray	726-321 ①	24	1 ... 32	
		○ white/gray	726-322 ①	24	33 ... 64	
	Matrix patchboard; dark gray modules; vertical module marking on sides 1 and 2; 32-pole	● blue	726-141 ① ⑤	20	1 ... 32	
	● blue	726-142 ① ⑤	20	33 ... 64		
	● blue	726-241 ② ⑤	20	1 ... 32		
	● blue	726-242 ② ⑤	20	33 ... 64		
	● blue	726-341 ② ⑤	24	1 ... 32		
	● blue	726-342 ② ⑤	24	33 ... 64		
<b>Matrix patchboard; 48-pole</b>						
	Matrix patchboard; dark gray modules; vertical module marking on sides 1 and 2; 48-pole	○ white/gray	726-421 ①	10	1 ... 48	500 V/6 kV/3 ④; I <sub>N</sub> 10 A; 300 V, 10 A ⑤; 300 V, 10 A ⑥
	Matrix patchboard; dark gray modules; vertical module marking on sides 1 and 2; 48-pole	○ white/gray	726-521 ②	10	1 ... 48	
	Matrix patchboard; dark gray modules; vertical module marking on sides 1 and 2; 48-pole	● blue	726-441 ① ⑤	10	1 ... 48	
	Matrix patchboard; dark gray modules; vertical module marking on sides 1 and 2; 48-pole	● blue	726-541 ② ⑤	10	1 ... 48	
<b>Matrix patchboard; 80-pole</b>						
	Matrix patchboard; dark gray modules; vertical module marking on sides 1 and 2; 80-pole	○ white/gray	726-721 ①	8	1 ... 80	500 V/6 kV/3 ④; I <sub>N</sub> 10 A; 300 V, 10 A ⑤; 300 V, 10 A ⑥
	Matrix patchboard; dark gray modules; vertical module marking on sides 1 and 2; 80-pole	○ white/gray	726-821 ②	8	1 ... 80	
	Matrix patchboard; dark gray modules; vertical module marking on sides 1 and 2; 80-pole	● blue	726-741 ① ⑤	8	1 ... 80	
	Matrix patchboard; dark gray modules; vertical module marking on sides 1 and 2; 80-pole	● blue	726-841 ② ⑤	8	1 ... 80	
<b>Common potential matrix patchboard; 24-pole</b>						
	Common potential matrix patchboard; dark gray modules; vertical module marking; with 1 supply terminal block incl. end plate; for 19" racks	○ gray	726-601 ③	10	1 ... 24	Side 1: I <sub>N</sub> 24 A; Side 1: I <sub>N</sub> 76 A
	Common potential matrix patchboard; dark gray modules; vertical module marking; with 2 supply terminal blocks incl. end plate; for 19" racks	○ gray	726-602 ③	10	1 ... 24	
	Common potential matrix patchboard; dark gray modules; vertical module marking; with 1 supply terminal block incl. end plate; for 19" racks	○ white	726-611 ③	10	1 ... 24	
	Common potential matrix patchboard; dark gray modules; vertical module marking; with 2 supply terminal blocks incl. end plate; for 19" racks	○ white	726-612 ③	10	1 ... 24	
	Common potential matrix patchboard; dark gray modules; vertical module marking; with 1 supply terminal block incl. end plate; for 19" racks	● blue	726-631 ③ ⑤	10	1 ... 24	
	Common potential matrix patchboard; dark gray modules; vertical module marking; with 2 supply terminal blocks incl. end plate; for 19" racks	● blue	726-632 ③ ⑤	10	1 ... 24	
	Common potential matrix patchboard; dark gray modules; vertical module marking; with 1 supply terminal block incl. end plate; for 19" racks	● green-yellow	726-621 ③	10	1 ... 24	
	Common potential matrix patchboard; dark gray modules; vertical module marking; with 2 supply terminal blocks incl. end plate; for 19" racks	● green-yellow	726-622 ③	10	1 ... 24	

① Side 1: 3 x (0.08 ... 1.5 mm<sup>2</sup> / 28 ... 16 AWG);  
Side 2: 3 x (0.08 ... 1.5 mm<sup>2</sup> / 28 ... 16 AWG);  
Strip length: 8 ... 10 mm / 0.31 ... 0.39 inch

② Side 1: 3 x (0.08 ... 1.5 mm<sup>2</sup> / 28 ... 16 AWG);  
Side 2: 2 x (0.08 ... 2.5 mm<sup>2</sup> / 28 ... 14 AWG);  
Strip length: 8 ... 10 mm / 0.31 ... 0.39 inch

③ Side 1: 24 x (2 x 0.08 ... 2.5 mm<sup>2</sup> / 28 ... 14 AWG);  
Strip length: 8 ... 10 mm / 0.31 ... 0.39 inch  
Side 2: 1 x or 2 x (0.5 ... 16 mm<sup>2</sup> / 20 ... 4 AWG);  
Strip length: 18 ... 20 mm / 0.71 ... 0.79 inch

④ 500 V = rated voltage  
6 kV = rated impulse voltage  
3 = pollution degree











⑤ Suitable for Ex i applications

Marking: WMB/WMB Inline/Marking strips

# WAGO Terminal Block for Matrix Patching; WAGO Common Potential Terminal Block

## - 727 Series

### 1,5 mm<sup>2</sup>

Image	Description	Color	Item No.	PU	Dimensions (W x H x D)	Electrical Data
<b>4-level terminal block for matrix patching</b>						
	4-level terminal block for matrix patching; with locking clips; no marking; 4 x pairs of clamping units on the same level; for DIN 35 x 7.5 rail	○ gray ○ white ● blue	727-219 727-221 727-223 ②	50 50 50	7,62 x 62 x 126 mm / 0.3 x 2.44 x 4.96 inch	250 V/4 kV/3 ①; I <sub>N</sub> 12 A; 300 V, 10 A ②; 300 V, 10 A ③
	4-level terminal block for matrix patching; with locking clips; no marking; 4 x pairs of clamping units on the same level; for DIN 35 x 15 rail	○ gray ○ white ● blue	727-229 727-231 727-233	50 50 50		
	4-level terminal block for matrix patching; without locking clips; no marking; 4 x pairs of clamping units on the same level; for DIN 35 x 7.5 rail	○ gray ○ white ● blue	727-220 727-222 727-224 ②	50 50 50	7,62 x 44,5 x 126 mm / 0.3 x 1.75 x 4.96 inch	
	4-level terminal block for matrix patching; without locking clips; no marking; 4 x pairs of clamping units on the same level; for DIN 35 x 15 rail	○ gray ○ white ● blue	727-230 727-232 727-234	50 50 50		
	4-level terminal block for matrix patching; with locking clips; no marking; all clamping units connected to the same current bar; for DIN 35 x 7.5 rail	● orange ○ light gray	727-225 727-227	50 50	7,62 x 62 x 126 mm / 0.3 x 2.44 x 4.96 inch	250 V/4 kV/3 ①; I <sub>N</sub> 18 A; 300 V, 10 A ②; 300 V, 10 A ③
	4-level terminal block for matrix patching; with locking clips; no marking; all clamping units connected to the same current bar; for DIN 35 x 15 rail	● orange ○ light gray	727-235 727-237	50 50		
	4-level terminal block for matrix patching; without locking clips; no marking; all clamping units connected to the same current bar; for DIN 35 x 7.5 rail	● orange ○ light gray	727-226 727-228	50 50	7,62 x 44,5 x 126 mm / 0.3 x 1.75 x 4.96 inch	
	4-level terminal block for matrix patching; without locking clips; no marking; all clamping units connected to the same current bar; for DIN 35 x 15 rail	● orange ○ light gray	727-236 727-238	50 50		
	4-level end plate; 7.62 mm thick	● orange ○ gray	727-217 727-213	25 25	7,62 x 44,3 x 126 mm / 0.3 x 1.74 x 4.96 inch	
<b>8-level terminal block for matrix patching</b>						
	8-level terminal block for matrix patching; with locking clips; no marking; 8 x pairs of clamping units on the same level; for DIN 35 x 7.5 rail	○ gray ○ white ● blue	727-119 727-121 727-123 ②	25 25 25	7,62 x 76 x 226 mm / 0.3 x 2.99 x 8.9 inch	250 V/4 kV/3 ①; I <sub>N</sub> 12 A; 300 V, 10 A ②; 300 V, 10 A ③
	8-level terminal block for matrix patching; with locking clips; no marking; 8 x pairs of clamping units on the same level; for DIN 35 x 15 rail	○ gray ○ white ● blue	727-129 727-131 727-133	25 25 25		
	8-level terminal block for matrix patching; without locking clips; no marking; 8 x pairs of clamping units on the same level; for DIN 35 x 7.5 rail	○ gray ○ white ● blue	727-120 727-122 727-124 ②	25 25 25	7,62 x 58,5 x 226 mm / 0.3 x 2.3 x 8.9 inch	
	8-level terminal block for matrix patching; without locking clips; no marking; 8 x pairs of clamping units on the same level; for DIN 35 x 15 rail	○ gray ○ white ● blue	727-130 727-132 727-134	25 25 25		
	8-level terminal block for matrix patching; with locking clips; no marking; all clamping units connected to the same current bar; for DIN 35 x 7.5 rail	● orange ○ light gray	727-125 727-127	25 25	7,62 x 76 x 226 mm / 0.3 x 2.99 x 8.9 inch	250 V/4 kV/3 ①; I <sub>N</sub> 18 A; 300 V, 10 A ②; 300 V, 10 A ③
	8-level terminal block for matrix patching; with locking clips; no marking; all clamping units connected to the same current bar; for DIN 35 x 15 rail	● orange ○ light gray	727-135 727-137	25 25		
	8-level terminal block for matrix patching; without locking clips; no marking; all clamping units connected to the same current bar; for DIN 35 x 7.5 rail	● orange ○ light gray	727-126 727-128	25 25	7,62 x 58,5 x 226 mm / 0.3 x 2.3 x 8.9 inch	
	8-level terminal block for matrix patching; without locking clips; no marking; all clamping units connected to the same current bar; for DIN 35 x 15 rail	● orange ○ light gray	727-136 727-138	25 25		
	8-level end plate; 7.62 mm thick	● orange ○ gray	727-117 727-113	25 25	7,62 x 58,3 x 226 mm / 0.3 x 2.3 x 8.9 inch	

Conductor range: 0.08 ... 1.5 mm<sup>2</sup>; 28 ... 16 AWG;  
Strip length: 8 ... 10 mm / 0.31 ... 0.39 inch

① 250 V = rated voltage  
4 kV = rated impulse voltage  
3 = pollution degree

② suitable for Ex i applications

Marking: WMB/WMB Inline/Marking strips

## WAGO Busbar Terminal Block – 812 Series

### 4 / 16 mm<sup>2</sup>

Image	Description	Color	Item No.	PU	Dimensions (W x H x D)	Electrical Data
<b>Busbar terminal block (4 mm<sup>2</sup>)</b>						
	Busbar terminal block (4 mm <sup>2</sup> ); with Push-in CAGE CLAMP® connection	● blue	812-104	10	75 x 30 x 27,5 mm / 2.95 x 1.18 x 1.08 inch	1000 V/6 kV/3 ①; I <sub>N</sub> 96 A; 600 V, 20 A <b>VA</b> ; 600 V, 95 A <b>CE</b>
		○ light gray	812-101	10		
		● dark gray	812-102	10		
		● red	812-103	10		
		● green-yellow	812-100	10		
	Ground busbar terminal block (4 mm <sup>2</sup> ); with Push-in CAGE CLAMP® connection				75 x 30 x 27,5 mm / 2.95 x 1.18 x 1.08 inch	
	Busbar; tin-plated; 1000 mm long; Copper (10 x 3) mm		210-133	1		
<b>Busbar terminal block (16 mm<sup>2</sup>)</b>						
	Busbar terminal block (16 mm <sup>2</sup> ); with CAGE CLAMP® connection	● blue	812-114	12	38 x 42,5 x 43,5 mm / 1.5 x 1.67 x 1.71 inch	1000 V/6 kV/3 ①; I <sub>N</sub> 96 A; 600 V, 20 A <b>VA</b> ; 600 V, 95 A <b>CE</b>
		○ light gray	812-111	12		
		● dark gray	812-112	12		
		● red	812-113	12		
	Ground busbar terminal block (16 mm <sup>2</sup> ); with CAGE CLAMP® connection	● green-yellow	812-110	12	38 x 42,5 x 43,5 mm / 1.5 x 1.67 x 1.71 inch	
	Busbar; tin-plated; 1000 mm long; Copper (10 x 3) mm		210-133	1		
	Finger guard; touch-proof cover protects unused conductor entries	● yellow	284-400	25		
<b>Busbar carrier</b>						
	Insulated busbar carrier; 12 mm wide	○ gray	812-140	25	12 x 41,7 x 80 mm / 0.47 x 1.64 x 3.15 inch	
	Ground busbar carrier; with DIN-35 rail contact; 11 mm wide	● green-yellow	812-141	25	11 x 36 x 54,5 mm / 0.43 x 1.42 x 2.11 inch	



Snapping a ground busbar terminal block onto the N-busbar



Unlock right and left positions to remove the ground busbar terminal block. Then pull up the block from the busbar.

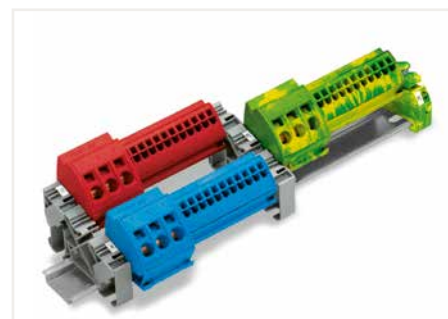

Mixed 4 mm<sup>2</sup> (12 AWG) and 16 mm<sup>2</sup> (6 AWG) busbar terminal blocks

① Conductor range: 0.08 ... 1.5 mm<sup>2</sup>; 28 ... 16 AWG;  
Strip length: 8 ... 10 mm / 0.31 ... 0.39 inch

② Conductor range: 0.08 ... 1.5 mm<sup>2</sup>; 28 ... 16 AWG;  
Strip length: 8 ... 10 mm / 0.31 ... 0.39 inch

③ 500 V = rated voltage  
6 kV = rated impulse voltage  
3 = pollution degree



# Rail-Mount Terminal Blocks Mini; for DIN-15 and DIN-35 Rails

## 264 Series

### Description and Installation



**CAGE CLAMP® termination:**  
Inserting a conductor.  
With ferruled conductors, it is necessary to use a terminal block one size smaller than the conductor's nominal cross section.



Commoning with comb-style jumper bar.

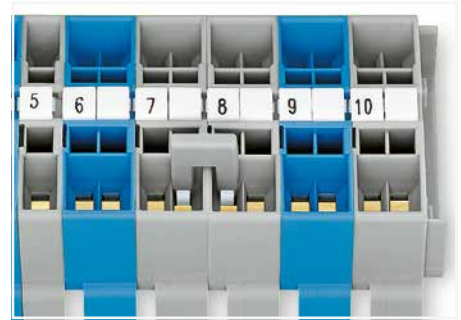

Commoning with comb-style jumper bar.

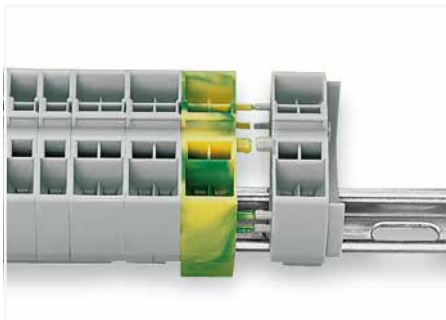

Quick assembly keys prevent reverse mounting.

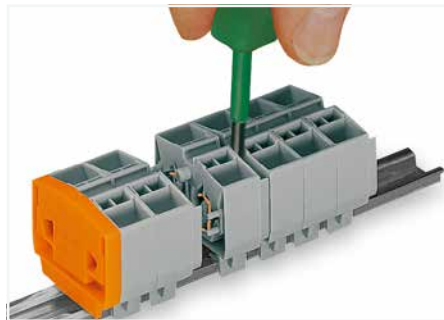

Separate terminal strip and slide individual terminal block laterally.



Remove terminal block from the DIN-rail with a levering action.

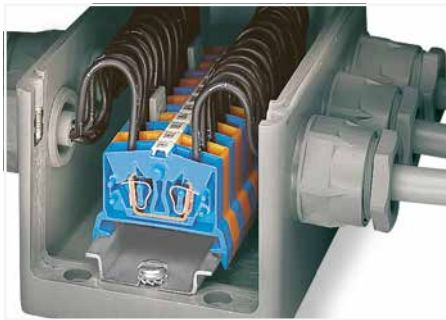

Easy-to-use miniature blocks that require minimal enclosure space.



Marking with T-marker tag (209-290).



Marking via Mini-WSB Quick Marking System.



Testing by touch contact to the CAGE CLAMP® spring (limited to 0.5 A and 48 V test voltage) – test pins are not protected against accidental contact.



Testing via CAGE CLAMP® on the current bar (max. nominal current: 6 A) – CAGE CLAMP® clamps individual test contacts. The maximum test voltage is 400 V.

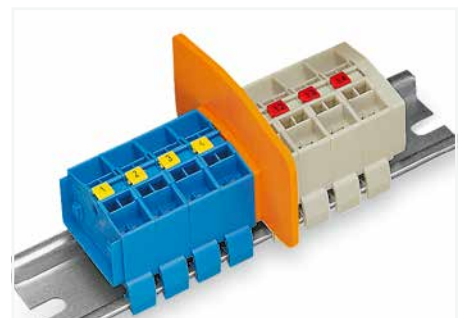









Ex e/Ex i separator plate for miniature rail-mount terminal blocks.

4

# WAGO Mini Through Terminal Block; Front-Entry Wiring; WAGO Terminal Strip – 264 Series

## 2,5 mm<sup>2</sup>

Image	Description	Color	2-Conductor Terminal Block ① Item No.	4-Conductor Terminal Block ② Item No.	PU	Electrical Data
<b>Mini through terminal block</b>						
	End terminal block; with mounting flange; for screw or similar mounting types; 3.2 mm mounting hole diameter	<ul style="list-style-type: none"> <li>○ gray</li> <li>● blue</li> <li>● orange</li> <li>● green-yellow</li> <li>○ light gray</li> </ul>	<ul style="list-style-type: none"> <li>264-301</li> <li>264-304 ②</li> <li>264-306</li> <li>264-307</li> <li>264-130 ③</li> </ul>	<ul style="list-style-type: none"> <li>264-331</li> <li>264-334 ②</li> <li>264-336</li> <li>264-337</li> <li>264-230 ③</li> </ul>	<ul style="list-style-type: none"> <li>100</li> <li>100</li> <li>100</li> <li>100</li> <li>100</li> </ul>	<ul style="list-style-type: none"> <li>800 V/8 kV/3 ①;</li> <li>I<sub>N</sub> 24 A;</li> <li>300 V, 20 A ④;</li> <li>600 V, 20 A ⑤</li> </ul>
	Center terminal block; required between end plate and end terminal block for terminal strips with mounting flanges	<ul style="list-style-type: none"> <li>○ gray</li> <li>● blue</li> <li>● orange</li> <li>● green-yellow</li> <li>○ light gray</li> </ul>	<ul style="list-style-type: none"> <li>264-321</li> <li>264-324 ②</li> <li>264-326</li> <li>264-327</li> <li>264-131 ③</li> </ul>	<ul style="list-style-type: none"> <li>264-351</li> <li>264-354 ②</li> <li>264-356</li> <li>264-357</li> <li>264-231 ③</li> </ul>	<ul style="list-style-type: none"> <li>100</li> <li>100</li> <li>100</li> <li>100</li> <li>100</li> </ul>	<ul style="list-style-type: none"> <li>800 V/8 kV/3 ①;</li> <li>I<sub>N</sub> 24 A;</li> <li>300 V, 20 A ④;</li> <li>600 V, 20 A ⑤</li> </ul>
	Center terminal block; with snap-in mounting foot; required between end plate and end terminal block for terminal strips with mounting flanges	<ul style="list-style-type: none"> <li>○ gray</li> <li>● blue</li> <li>● orange</li> <li>● green-yellow</li> <li>○ light gray</li> </ul>	<ul style="list-style-type: none"> <li>264-311</li> <li>264-314 ②</li> <li>264-316</li> <li>264-317</li> <li>264-180 ③</li> </ul>	<ul style="list-style-type: none"> <li>264-341</li> <li>264-344 ②</li> <li>264-346</li> <li>264-347</li> <li>264-280 ③</li> </ul>	<ul style="list-style-type: none"> <li>100</li> <li>100</li> <li>100</li> <li>100</li> <li>100</li> </ul>	<ul style="list-style-type: none"> <li>800 V/8 kV/3 ①;</li> <li>I<sub>N</sub> 24 A;</li> <li>300 V, 20 A ④;</li> <li>600 V, 20 A ⑤</li> </ul>
	End and intermediate plate; 4 mm thick	<ul style="list-style-type: none"> <li>● orange</li> <li>○ gray</li> <li>○ light gray</li> </ul>	<ul style="list-style-type: none"> <li>264-361</li> <li>264-364</li> <li>264-363</li> </ul>	<ul style="list-style-type: none"> <li>264-361</li> <li>264-364</li> <li>264-363</li> </ul>	<ul style="list-style-type: none"> <li>25</li> <li>25</li> <li>25</li> </ul>	
	Mini through terminal block; for DIN-35 rail	<ul style="list-style-type: none"> <li>○ gray</li> <li>● blue</li> <li>● orange</li> <li>○ light gray</li> </ul>	<ul style="list-style-type: none"> <li>264-711</li> <li>264-714 ②</li> <li>264-716</li> <li>264-125 ③</li> </ul>	<ul style="list-style-type: none"> <li>264-731</li> <li>264-734 ②</li> <li>264-736</li> <li>264-225 ③</li> </ul>	<ul style="list-style-type: none"> <li>100</li> <li>100</li> <li>100</li> <li>100</li> </ul>	<ul style="list-style-type: none"> <li>800 V/8 kV/3 ①;</li> <li>I<sub>N</sub> 24 A;</li> <li>300 V, 20 A ④;</li> <li>600 V, 20 A ⑤</li> </ul>
	Mini ground terminal block; for DIN-35 rail	<ul style="list-style-type: none"> <li>● green-yellow</li> <li>● green-yellow</li> </ul>		<ul style="list-style-type: none"> <li>264-737</li> <li>264-737/999-950 ③</li> </ul>	<ul style="list-style-type: none"> <li>100</li> <li>100</li> </ul>	
	End and intermediate plate; 4 mm thick	<ul style="list-style-type: none"> <li>● orange</li> <li>○ gray</li> <li>○ light gray</li> </ul>	<ul style="list-style-type: none"> <li>264-369</li> <li>264-368</li> <li>264-370</li> </ul>	<ul style="list-style-type: none"> <li>264-369</li> <li>264-368</li> <li>264-370</li> </ul>	<ul style="list-style-type: none"> <li>25</li> <li>25</li> <li>25</li> </ul>	
<b>Terminal strips</b>						
	Terminal strips; with mounting flanges					
	2-pole	○ gray	264-102	264-202	100	800 V/8 kV/3 ①;
	⋮		⋮	⋮		I <sub>N</sub> 24 A;
	12-pole	○ gray	264-112	264-212	25	300 V, 20 A ④;
						600 V, 20 A ⑤
	Terminal strips; with snap-in mounting feet					
	2-pole	○ gray	264-152	264-252	100	800 V/8 kV/3 ①;
	⋮		⋮	⋮		I <sub>N</sub> 24 A;
	12-pole	○ gray	264-162	264-262	25	300 V, 20 A ④;
						600 V, 20 A ⑤
<b>Accessories</b>						
	Comb-style jumper bar; insulated; reduces maximum conductor size to 1.5 mm <sup>2</sup> ; I <sub>N</sub> 16 A;	○ gray	264-402	264-402	25	

4

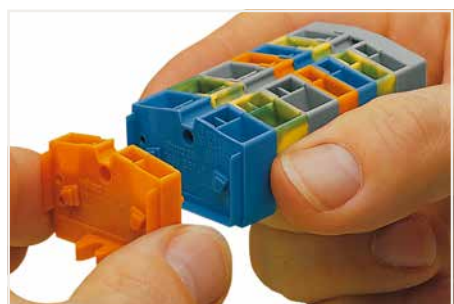

Mounting an "end terminal block" with mounting flange.

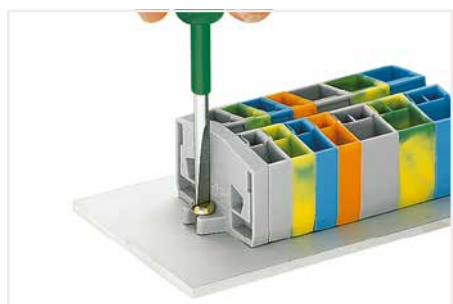

Mounting and securing a terminal strip directly to the plate via screw-type flanges.



Commoning with comb-style jumper bar.

Conductor range: 0.08 ... 2.5 mm<sup>2</sup>; 28 ... 12 AWG;  
Strip length: 8 ... 9 mm / 0.31 ... 0.35 inch

① Dimensions of 2-conductor terminal blocks (W x H x D): 6 x 22,1 x 32 mm / 0.24 x 0.87 x 1.26 inch

② Dimensions of 4-conductor terminal blocks (W x H x D): 10 x 22,1 x 32 mm / 0.39 x 0.87 x 1.26 inch

③ 800 V = rated voltage  
8 kV = rated impulse voltage  
3 = pollution degree

② suitable for Ex i applications  
③ Suitable for Ex e II applications; 690 V; 23 A  
Marking: WMB/WMB Inline/Marking strips

# WAGO Mini Through Terminal Blocks; Side-Entry Wiring; WAGO Terminal Strips – 260 / 261 / 262 Series Operation

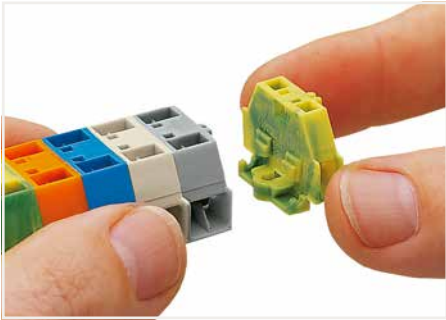

Assembling modular terminal blocks into terminal strips.



Mounting an end plate.

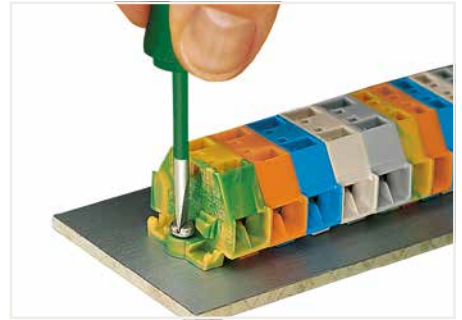

Mounting and securing a terminal strip directly to the plate via screw-type flanges.

4



Inserting a conductor.

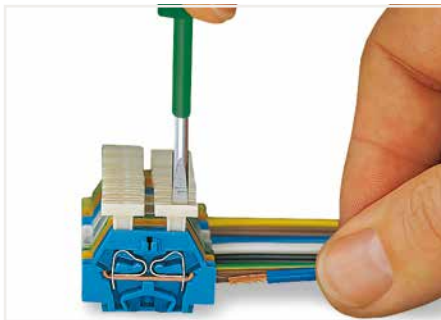

Inserting a conductor via push-button.



Securing a mounting foot (209-123) to the terminal strip with mounting flanges (distance between mounting feet: approx. 35 ... 40 mm).



Marking with self-adhesive marking strips.



Marking by direct printing (upon request).

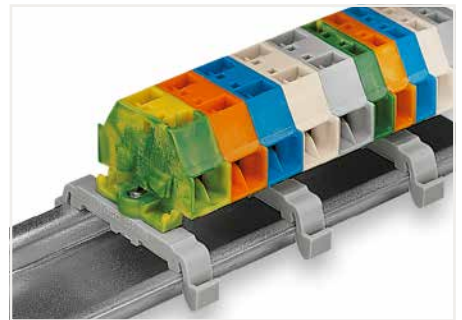

Terminal strip with mounting flanges on DIN-35 rail

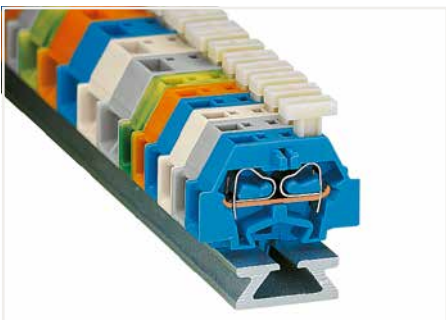

Terminal strip with push-buttons on one side

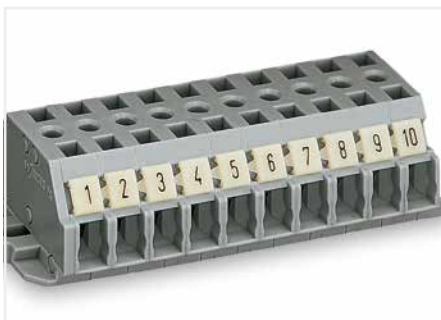

Terminal strip with marker slot for Mini-WSB Quick marking system (see Full Line Catalog, Volume 6).

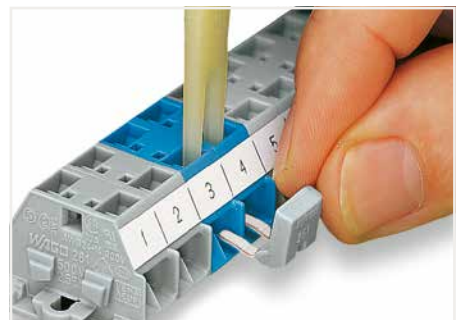











Commoning with comb-style jumper bar.



# WAGO Mini Through Terminal Block; Side-Entry Wiring; WAGO Terminal Strips

## - 260 / 261 / 262 Series

### 1,5 / 2,5 / 4 mm<sup>2</sup>

Image	Description	Color	2-Conductor Terminal Block Item No.	4-Conductor Terminal Block Item No.	PU	Electrical Data	
<b>Modular terminal block/terminal strip; 1.5 mm<sup>2</sup> ①</b>							
	Terminal block; with mounting flange; for screw or similar mounting types; 3.2 mm mounting hole diameter	○ gray	260-301	260-331	300	400 V/6 kV/3 ④; I <sub>n</sub> 18 A; 300 V, 10 A ⑤; 300 V, 15 A ⑥	
		○ light gray	260-303	260-333	300		
		● blue	260-304	260-334	300		
		● orange	260-306	260-336	300		
		● green-yellow	260-307	260-337	300		
	End plate; with mounting flange	○ gray	260-361	260-361	50		
	Terminal strip; with mounting flanges; for screw or similar mounting types; 3.2 mm mounting hole diameter					400 V/6 kV/3 ④; I <sub>n</sub> 18 A; 300 V, 10 A ⑤; 300 V, 15 A ⑥	
		2-pole	○ gray	260-102	260-202		100
		⋮		⋮	⋮		
	12-pole	○ gray	260-112	260-212	25		
<b>Modular terminal block; 2.5 mm<sup>2</sup> ②</b>							
	Terminal block; with mounting flange; for screw or similar mounting types; 3.2 mm mounting hole diameter	○ gray	261-301	261-331	200	500 V/6 kV/3 ④; I <sub>n</sub> 24 A; 300 V, 15 A ⑤; 300 V, 20 A ⑥	
		○ light gray	261-303	261-333	200		
		● blue	261-304 ⑤	261-334 ⑤	200		
		● orange	261-306	261-336	200		
		● green-yellow	261-307	261-337	200		
	End plate; with mounting flange	○ gray	261-361	261-361	50		
	Terminal strip; with mounting flanges; for screw or similar mounting types; 3.2 mm mounting hole diameter					500 V/6 kV/3 ④; I <sub>n</sub> 24 A; 300 V, 15 A ⑤; 300 V, 20 A ⑥	
		2-pole	○ gray	261-102	261-202		100
		⋮		⋮	⋮		
	12-pole	○ gray	261-112	261-212	25		
<b>Modular terminal block; 4 mm<sup>2</sup> ③</b>							
	2-conductor terminal block; with mounting flange; for screw or similar mounting types; 3.2 mm mounting hole diameter	○ gray	262-301	262-331	100	630 V/8 kV/3 ④; I <sub>n</sub> 24 A; 300 V, 20 A ⑤; 300 V, 20 A ⑥	
		● blue	262-304 ⑤	262-334 ⑤	100		
		● orange	262-306	262-336	100		
		● green-yellow	262-307	262-337	100		
	End plate; with mounting flange	○ gray	262-361	262-361	50		
	Terminal strip; with mounting flanges; for screw or similar mounting types; 3.2 mm mounting hole diameter					630 V/8 kV/3 ④; I <sub>n</sub> 24 A; 300 V, 20 A ⑤; 300 V, 20 A ⑥	
		2-pole	○ gray	262-102	262-202		100
		⋮		⋮	⋮		
	12-pole	○ gray	262-112	262-212	25		
<b>Accessories</b>							
	Comb-style jumper bar; insulated; I <sub>n</sub> 16 A						
	for 260 Series; reduces conductor size to 1 mm <sup>2</sup>	○ gray	260-402	260-402	25		
	for 261 Series; reduces conductor size to 1.5 mm <sup>2</sup>	○ gray	261-402	261-402	25		
	for 262 Series; reduces conductor size to 2.5 mm <sup>2</sup>	○ gray	262-402	262-402	25		

**260 Series ①**

Conductor range: 0.08 ... 1.5 mm<sup>2</sup>; 28 ... 16 AWG;  
Strip length: 8 ... 9 mm / 0.31 ... 0.35 inch

Dimensions of 2-conductor terminal block (W x H x D):  
5 x 17 x 25 mm / 0.2 x 0.67 x 0.98 inch

Dimensions of 4-conductor terminal block (W x H x D):  
8 x 17 x 25 mm / 0.32 x 0.67 x 0.98 inch

**261 Series ②**

Conductor range: 0.08 ... 2.5 mm<sup>2</sup>; 28 ... 14 AWG;  
Strip length: 8 ... 9 mm / 0.31 ... 0.35 inch

Dimensions of 2-conductor terminal block (W x H x D):  
6 x 18 x 28 mm / 0.24 x 0.71 x 1.1 inch

Dimensions of 4-conductor terminal block (W x H x D):  
10 x 18 x 28 mm / 0.39 x 0.71 x 1.1 inch

**262 Series ③**

Conductor range: 0.08 ... 4 mm<sup>2</sup>; 28 ... 12 AWG;  
Strip length: 9 ... 10 mm / 0.35 ... 0.39 inch

Dimensions of 2-conductor terminal block (W x H x D):  
7 x 23 x 33,5 mm / 0.28 x 0.91 x 1.32 inch

Dimensions of 4-conductor terminal block (W x H x D):  
12 x 23 x 33,5 mm / 0.47 x 0.91 x 1.32 inch

**General**

④ 400/500/630 V = rated voltage;  
6/8 kV = rated impulse voltage;  
3 = pollution degree

⑤ suitable for Ex i applications

# WAGO Chassis-Mount Terminal Strip – 862 Series

4 mm<sup>2</sup>

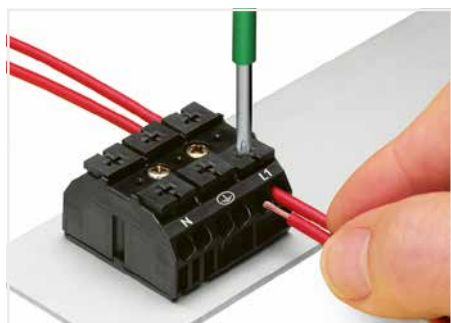

Terminating four conductors per pole – solid and fine-stranded.



Inserting a conductor via push-button.



Testing with a 2 mm Ø test plug (max. 42 V).

5



Makes an automatic contact to the mounting plate. The plate's varnish is instantly penetrated.

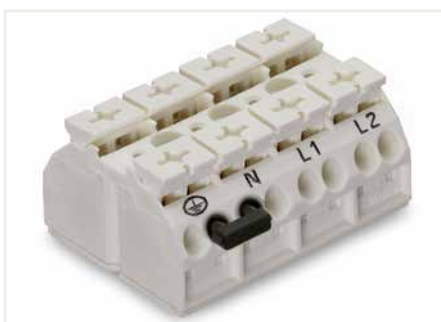

Commoning using a comb-style jumper bar (862-482).

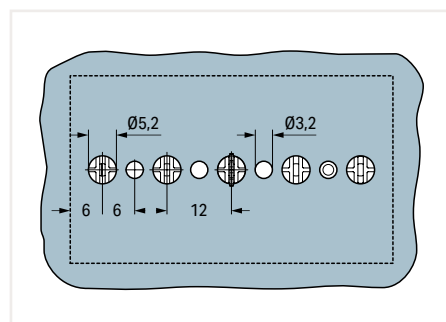

Dimensions (in mm) for GND contact and snap-in mounting foot (Ø 5.2 mm)

Image	Pole Number	Marking	Description	Color	Item No.	Color	Item No.	PU
<b>4-conductor chassis-mount terminal strip; for mounting via screw and nut (3 mm Ø) or for self-tapping screw (2.9 mm Ø) from top; white</b>								
	2	N-L1	with 2 x pin	● black	862-2552	○ white	862-2652	500
	2	L1-N	with 2 x pin	● black	862-1552	○ white	862-1652	500
	2	L1-N	with 2 x pin	● black	862-1552/999-950 ①	○ white	862-1652/999-950 ①	500
	2	plain	with 2 x pin	● black	862-552	○ white	862-652	500
	3	N-PE-L1	without GND contact	● black	862-2503	○ white	862-2603	250
	3	PE-N-L1	without GND contact	● black	862-1503	○ white	862-1603	250
	3	PE-N-L1	without GND contact	● black	862-1503/999-950 ①	○ white	862-1603/999-950 ①	250
	3	plain	without GND contact	● black	862-503	○ white	862-603	250
	3	N-PE-L1	with GND contact	● black	862-8503	○ white	862-8603	250
	3	PE-N-L1	with GND contact	● black	862-9503	○ white	862-9603	250
	4	N-PE-L1-L2	without GND contact	● black	862-2504	○ white	862-2604	200
	4	PE-N-L1-L2	without GND contact	● black	862-1504	○ white	862-1604	200
	4	PE-N-L1-L2	without GND contact	● black	862-1504/999-950 ①	○ white	862-1604/999-950 ①	200
	4	plain	without GND contact	● black	862-504	○ white	862-604	200
	4	N-PE-L1-L2	with GND contact	● black	862-8504	○ white	862-8604	200
	4	PE-N-L1-L2	with GND contact	● black	862-9504	○ white	862-9604	200
	5	L3-N-PE-L1-L2	without GND contact	● black	862-2505	○ white	862-2605	200
	5	PE-N-L1-L2-L3	without GND contact	● black	862-1505	○ white	862-1605	200
	5	PE-N-L1-L2-L3	without GND contact	● black	862-1505/999-950 ①	○ white	862-1605/999-950 ①	200
	5	plain	without GND contact	● black	862-505	○ white	862-605	200
5	L3-N-PE-L1-L2	with GND contact	● black	862-8505	○ white	862-8605	200	
5	PE-N-L1-L2-L3	with GND contact	● black	862-9505	○ white	862-9605	200	

Conductor range: 0.5 ... 4 mm<sup>2</sup> "s+f-st"; Push-in termination: 1 ... 4 mm<sup>2</sup> "s" and 1 ... 2.5 mm<sup>2</sup> "insulated ferrules; 12 mm"; 20 ... 12 AWG; Strip length: 10 ... 11 mm / 0.39 ... 0.43 inch

500 V/6 kV/3; I<sub>n</sub> 32 A; 300 V, 20 A **VA**; 300 V, 20 A **®**  
 500 V = rated voltage  
 8 kV= rated impulse voltage  
 3 = pollution degree

① Suitable for Ex e II applications; 440 V; 28 A

## WAGO Chassis-Mount Terminal Strip – 862 Series

### 4 mm<sup>2</sup>

Image	Pole Number	Marking	Description	Color	Item No.	Color	Item No.	PU
<b>4-conductor chassis-mount terminal strip; for self-tapping screw (2.9 mm Ø) from below</b>								
	2	N-L1	with 2 x pin	● black	862-2562	○ white	862-2662	500
	2	L1-N	with 2 x pin	● black	862-1562	○ white	862-1662	500
	2	L1-N	with 2 x pin	● black	862-1562/999-950 ①	○ white	862-1662/999-950 ①	500
	2	plain	with 2 x pin	● black	862-562	○ white	862-662	500
<b>4-conductor chassis-mount terminal strip; 1 snap-in foot per pole</b>								
	2	N-L1		● black	862-2532	○ white	862-2632	500
	2	L1-N		● black	862-1532	○ white	862-1632	500
	2	L1-N		● black	862-1532/999-959 ①	○ white	862-1632/999-959 ①	500
	2	plain		● black	862-532	○ white	862-632	500
	3	N-PE-L1	without GND contact	● black	862-2533	○ white	862-2633	250
	3	PE-N-L1	without GND contact	● black	862-1533	○ white	862-1633	250
	3	PE-N-L1	without GND contact	● black	862-1533/999-950 ①	○ white	862-1633/999-950 ①	250
	3	plain	without GND contact	● black	862-533	○ white	862-633	250
	3	N-PE-L1	with GND contact	● black	862-8533	○ white	862-8633	250
	3	PE-N-L1	with GND contact	● black	862-9533	○ white	862-9633	250
	4	N-PE-L1-L2	without GND contact	● black	862-2534	○ white	862-2634	200
	4	PE-N-L1-L2	without GND contact	● black	862-1534	○ white	862-1634	200
	4	PE-N-L1-L2	without GND contact	● black	862-1534/999-950 ①	○ white	862-1634/999-950 ①	200
	4	plain	without GND contact	● black	862-534	○ white	862-634	200
	4	N-PE-L1-L2	with GND contact	● black	862-8534	○ white	862-8634	200
	4	PE-N-L1-L2	with GND contact	● black	862-9534	○ white	862-9634	200
	5	L3-N-PE-L1-L2	without GND contact	● black	862-2525	○ white	862-2625	200
	5	PE-N-L1-L2-L3	without GND contact	● black	862-1525	○ white	862-1625	200
	5	PE-N-L1-L2-L3	without GND contact	● black	862-1525/999-950 ①	○ white	862-1625/999-950 ①	200
	5	plain	without GND contact	● black	862-525	○ white	862-625	200
5	L3-N-PE-L1-L2	with GND contact	● black	862-8525	○ white	862-8625	200	
5	PE-N-L1-L2-L3	with GND contact	● black	862-9525	○ white	862-9625	200	
<b>4-conductor chassis-mount terminal strip; Snap-in foot at pos. 1+3</b>								
	3	N-PE-L1	without GND contact	● black	862-2593	○ white	862-2693	250
	3	PE-N-L1	without GND contact	● black	862-1593	○ white	862-1693	250
	3	PE-N-L1	without GND contact	● black	862-1593/999-950 ①	○ white	862-1693/999-950 ①	250
	3	plain	without GND contact	● black	862-593	○ white	862-693	250
	3	N-PE-L1	with GND contact	● black	862-8593	○ white	862-8693	250
	3	PE-N-L1	with GND contact	● black	862-9593	○ white	862-9693	250
<b>4-conductor chassis-mount terminal strip; Snap-in foot at pos. 1+4</b>								
	4	N-PE-L1-L2	without GND contact	● black	862-2594	○ white	862-2694	200
	4	PE-N-L1-L2	without GND contact	● black	862-1594	○ white	862-1694	200
	4	PE-N-L1-L2	without GND contact	● black	862-1594/999-950 ①	○ white	862-1694/999-950 ①	200
	4	plain	without GND contact	● black	862-594	○ white	862-694	200
	4	N-PE-L1-L2	with GND contact	● black	862-8594	○ white	862-8694	200
	4	PE-N-L1-L2	with GND contact	● black	862-9594	○ white	862-9694	200
<b>4-conductor chassis-mount terminal strip; Snap-in foot at pos. 1+3+5</b>								
	5	L3-N-PE-L1-L2	without GND contact	● black	862-2515	○ white	862-2615	200
	5	PE-N-L1-L2-L3	without GND contact	● black	862-1515	○ white	862-1615	200
	5	PE-N-L1-L2-L3	without GND contact	● black	862-1515/999-950 ①	○ white	862-1615/999-950 ①	200
	5	plain	without GND contact	● black	862-515	○ white	862-615	200
	5	L3-N-PE-L1-L2	with GND contact	● black	862-8515	○ white	862-8615	200
	5	PE-N-L1-L2-L3	with GND contact	● black	862-9515	○ white	862-9615	200

# WAGO Field-Wiring Terminal Block for Lighting and Electrical Equipment – 294 Series

## 2,5 mm<sup>2</sup>

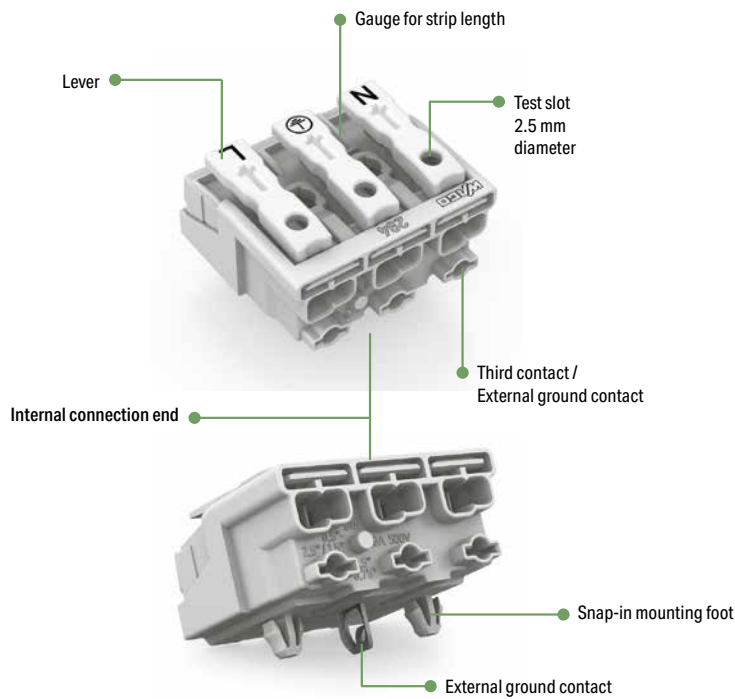

EUROPE
1 x 0.5 ... 2.5 mm <sup>2</sup> "s"
1 x 0.5 ... 1.5 mm <sup>2</sup> "s"
1 x 0.5 ... 0.75 mm <sup>2</sup> "s"
AMERICA
1 x AWG 18 ... 14 "s"
1 x AWG 18 ... 16 "s"
1 x AWG 18 "s"
JAPAN
1 x 0.8 ... 1.6 mm diam. "s"
1 x 0.8 ... 1 mm diam. "s"
1 x 0.8 mm diam. "s"

Internal connection:

PUSH WIRE® for internal wiring with solid conductors

EUROPE
2 x 0.5 ... 2.5 mm <sup>2</sup> "s, str, f-str"
AMERICA
2 x AWG 18 ... 12 "s"
2 x AWG 18 ... 14 "s, f-str"
JAPAN
2 x 0.8 ... 2 mm diam. "s"
2 x 0.5 ... 2 mm <sup>2</sup> "str, f-str"

External connection:

Push-in CAGE CLAMP® for field-wiring with all conductor types



Image	Pole Number	Marking	without GND contact Item No.	With Direct GND Contact Item No.	With Screw-Type GND Contact Item No.	With Snap-In GND Contact Item No.	With Angled Snap-In GND Contact Item No.
<b>Lighting terminal blocks; with 2 snap-in mounting feet</b>							
	2	plain	294-5002				
	2	N L	294-5012				
	2	N' L'	294-5022				
	2	DA- DA+	294-5032				
	2	- +	294-5072				
	2	1 N	294-5052				
	2	2 1	294-5042				
	3	plain	294-5003				
	3	N PE L	294-5013	294-5113	294-5413	294-5213	294-5313
	3	N' PE L'	294-5023	294-5123	294-5423	294-5223	294-5323
	3	1 PE N	294-5053	294-5153	294-5153	294-5253	294-5353
	4	plain	294-5004				
	4	1/L' 2/L PE N	294-5024	294-5124	294-5424	294-5224	294-5324
	4	1 2 PE N	294-5014	294-5114	294-5414	294-5214	294-5314
	4	4 3 2 1	294-5044				
	4	1/L' 2/L E N	294-5094/4025-000				
	5	plain	294-5005				
	5	L3 L2 L1 PE N	294-5015		294-5415	294-5215	294-5315
	5	L' N' L PE N	294-5025		294-5425	294-5225	294-5325
	5	DA+ DA- L PE N	294-5035		294-5435	294-5235	294-5335
	5	DA- N PE L DA+	294-5075	294-5175	294-5475	294-5275	294-5375
	5	3 N PE 1 2	294-5055	294-5155	294-5455	294-5255	294-5355
	5	5 4 3 2 1	294-5045				
	5	DA+ DA- L E N	294-5095/5025-000				
	5	L3 L2 L1 E N	294-5095/5026-000				
	5	L' N' L E N	294-5095/5027-000				

## WAGO Field-Wiring Terminal Block for Lighting and Electrical Equipment – 294 Series

### 2,5 mm<sup>2</sup>











Image	Pole Number	Marking	without GND contact Item No.	With Direct GND Contact Item No.	With Screw-Type GND Contact Item No.	With Snap-In GND Contact Item No.	With Angled Snap-In GND Contact Item No.
<b>Lighting terminal blocks; without snap-in mounting feet</b>							
	2	plain	294-4002				
	2	N L	294-4012				
	2	N' L'	294-4022				
	2	DA- DA+	294-4032				
	2	- +	294-4072				
	2	1 N	294-4052				
	2	2 1	294-4042				
	3	plain	294-4003				
	3	N PE L	294-4013		294-4413	294-4213	294-4313
	3	N' PE L'	294-4023		294-4423	294-4223	294-4323
	3	1 PE N	294-4053		294-4153	294-4253	294-4353
	4	plain	294-4004				
	4	1/L' 2/L PE N	294-4024		294-4424	294-4224	294-4324
	4	1 2 PE N	294-4014		294-4414	294-4214	294-4314
	4	4 3 2 1	294-4044				
	4	1/L' 2/L E N	294-4094/4025-000				
	5	plain	294-4005				
	5	L3 L2 L1 PE N	294-4015		294-4415	294-4215	294-4315
	5	L' N' L PE N	294-4025		294-4425	294-4225	294-4325
	5	DA+ DA- L PE N	294-4035		294-4435	294-4235	294-4335
	5	DA- N PE L DA+	294-4075		294-4475	294-4275	294-4375
	5	3 N PE 1 2	294-4055		294-4455	294-4255	294-4355
	5	5 4 3 2 1	294-4045				
	5	DA+ DA- L E N	294-4095/5025-000				
	5	L3 L2 L1 E N	294-4095/5026-000				
	5	L' N' L E N	294-4095/5027-000				
	6	plain	294-4006				
	7	plain	294-4007				

Image	Description	Color	Item No.	PU
<b>294 Series Accessories</b>				
	Assembly tool; presses snap-in mounting feet into the mounting plate; fits ground connections safely and easily		294-199	50
	Disconnection tool; removes conductors from PUSH WIRE® connections	● green	206-294	1
	Strain relief plate; with locking clip; for multicore cable: 1 x 5.2 ... 12 mm outer diameter	○ white	294-364	50
	Strain relief plate; with locking clip; for flat cables and individual conductors: min. 3 x 0.5 mm <sup>2</sup> , max. 5 x 2.5 mm <sup>2</sup> or 7 x 1.5 mm <sup>2</sup>	○ white	294-384	50
	Strain relief; with snap-in mounting feet; for 4.5 ... 12 mm cable diameter	○ white	294-370	500
	Strain relief; for screw/rivet mounting; for 4.5 ... 12 mm cable diameter	○ white	294-375	500

The following packaging units (PU) apply to the field-wiring terminal blocks:

Pole no. 2 = 1000; Pole no. 3 = 500; Pole no. 4 = 500 VPE; Pole no. 5 = 250; Pole no. 6 = 200; Pole no. 7 = 200

Conductor range: 0.5 ... 2.5 mm<sup>2</sup> "s+f-st"; Push-in termination: 0.5 ... 2.5 mm<sup>2</sup> "s" and 0.5 ... 1.5 mm<sup>2</sup> "insulated ferrules; 12 mm"; 18 ... 12 AWG;  
Strip length: 8 ... 9 mm / 0.31 ... 0.35 inch

500 V/4 kV/2; I<sub>n</sub> 24 A  
500 V = rated voltage  
4 kV = rated impulse voltage  
2 = pollution degree

# Current-Carrying Capacity Curves for Automotive Fuses; Current-Carrying Capacity Curve for X-COM®-SYSTEM

## Current-Carrying Capacity Curves for Automotive Fuses

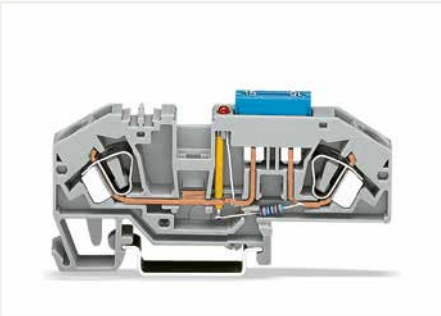

Nominal current ratings for fuse cartridges are defined differently in international standards. This is why the recommended continuous current-carrying capacity of the fuses is a max. 80 % of their nominal current according to DIN 72581/Part 3 (at a surrounding air temperature of 23 °C). Selecting the correct fuse cartridge is important for product safety within applications, as well as for fuse cartridge service life and reliability. Fuse cartridges will only operate perfectly as protection components (break-off point) if they are properly selected and used as intended (i.e., according to the most current and valid specifications, as well as data sheet characteristics), according to basic safety requirements (i.e., persons, animals and property must be protected against hazards).

### Information from the mini-automotive, blade-type fuse manufacturers

Derating T <sub>amb</sub> / °C	%	F <sub>T</sub>
-25	14	0.877
-20	13	0.885
-15	12	0.893
-10	11	0.901
-5	10	0.909
0	9	0.917
5	8	0.926
10	6	0.943
15	4	0.962
20	2	0.980
23	0	1.000
30	-2	1.020
35	-4	1.042
40	-6	1.064
45	-8	1.087
50	-10	1.111
55	-13	1.149
60	-16	1.190
65	-19	1.235
70	-22	1.282

Concerning product safety, fuse cartridges must generally be tested under both normal and faulty operating conditions within your application.

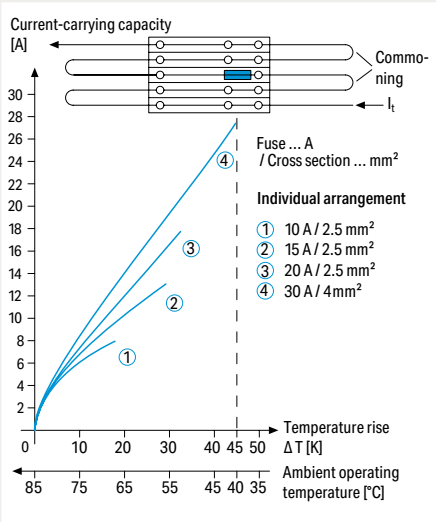

Application Notes for Use of Fuse Terminal Blocks  
Diagram: Individual Arrangement

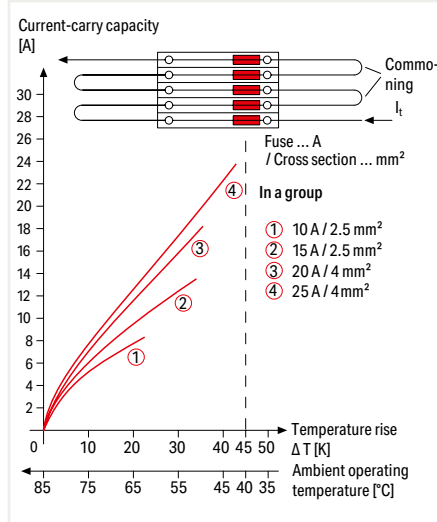

Application Notes for Use of Fuse Terminal Blocks  
Diagram: Block Arrangement

## Current-carrying capacity curve for X-COM®-SYSTEM 1-conductor/1-pin and 2-pin carrier terminal blocks and 1-conductor female connectors; per IEC/EN 60512-5-2

Both the design requirements and the current-carrying capacity of a connector must be checked by the user when selecting connectors. The function of a current-carrying capacity curve per EN 60512-5-2 is shown by an application using a current-carrying capacity curve for the X-COM®-SYSTEM:

This application requires each pole of a 4-pole connector be subjected to a load of 32 A. The basic curve determined for this pole number with a conductor cross-section of 4 mm<sup>2</sup> shows that this is possible up to a surrounding air temperature of 42 °C (107.6 °F). The current must be reduced at higher surrounding air temperatures, e.g., to 19 A at a surrounding air temperature of 80 °C (176 °F).

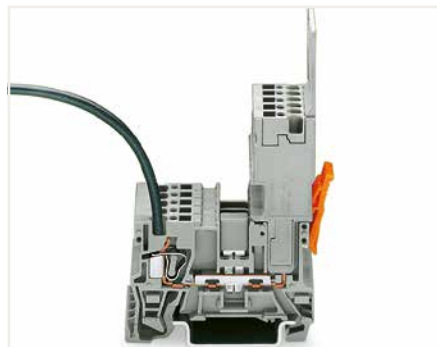
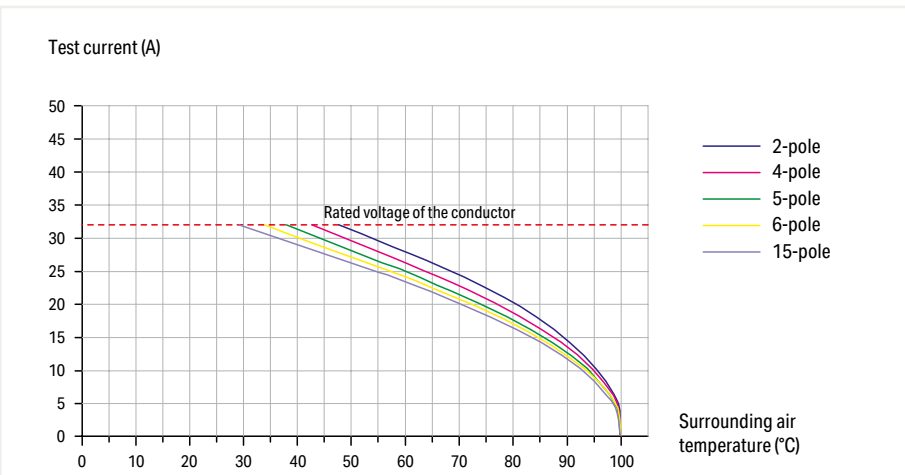

1-conductor/1-pin carrier terminal block, 769-176  
Conductor cross-section: 4 mm<sup>2</sup> (12 AWG)

1-conductor female plugs, 769-102 to 769-115  
Conductor cross-section: 4 mm<sup>2</sup> (12 AWG)  
Conductor loop length: 1 m

# Abbreviations; Material Specifications

## Abbreviations

"e": solid conductor  
 "m": stranded conductor  
 "f": fine-stranded conductor  
 "e+f": solid and fine-stranded conductors  
 "sol.": solid conductor  
 "f-st": fine-stranded conductor

AWG: American Wire Gauge  
 $I_N$  32 A: nominal current of 32 A (e.g., for jumpers)  
 WMB: WAGO Multi marking system  
 WSB: WAGO Quick marking system  
 MTBF: mean time between failures, per IEC 61709, at 25 °C  
 PU: packaging unit (other quantities upon request);  
 if not specified: 1 item

## Material Specifications

### Insulation Materials

WAGO primarily uses polyamide (PA 66 and PA 46) for housing current-conducting parts, as well as polyphthalamide (PPA) and polycarbonate (PC) for insulation material (see table). For more than 50 years, these materials have proven themselves in WAGO products and all are approved by certified third-party agencies. All listed halogen-free and flame-retardant polymer materials do not contain any heavy metals, silicone, asbestos or formaldehyde as formulation components.

### Contact Materials

Hard and extra-hard electrolytic copper (ECu), as well as extra-hard copper alloys, are the standard materials used for the current-carrying parts of all WAGO products. These materials combine excellent conductivity and good chemical resistance without the risk of stress-induced cracking.

### Contact surface

The special tin layer, which is the standard layer for all current-carrying parts in WAGO products, ensures perfect long-term protection against corrosive substances. Furthermore, these layers provide a gas-tight contact that ensures durable contact resistance. At the clamping unit, the conductor is embedded into the soft tin layer with high contact pressure. This protects the contact area against corrosion. The thick tin layer also ensures good solderability of both PCB terminal block and connector solder pins.

### Clamping spring material

Every WAGO clamping spring is made of high-quality, accurately tested austenitic chrome nickel steel (CrNi) with high tensile strength, which boasts proven, long-term corrosion resistance. It is resistant to sea spray, town gas and the industrial emissions sulfur dioxide, and hydrogen sulfide.

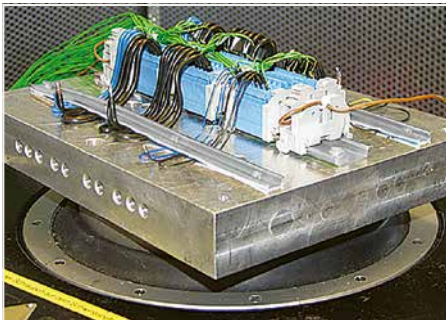

Shock Test per IEC/EN 60068-2-27; IEC/EN 61373 (Railway Applications)



Glow-Wire Test per IEC/EN 60998-1, IEC/EN 60695-2-11

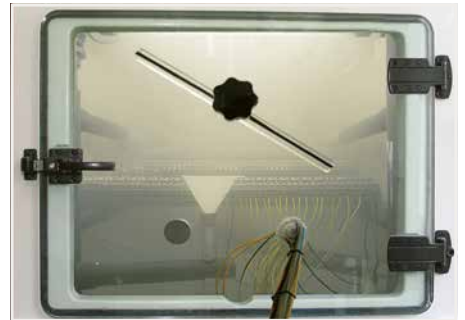

Salt Spray Test per IEC/EN 60068-2-11; DNV GL, LR (Marine Applications)

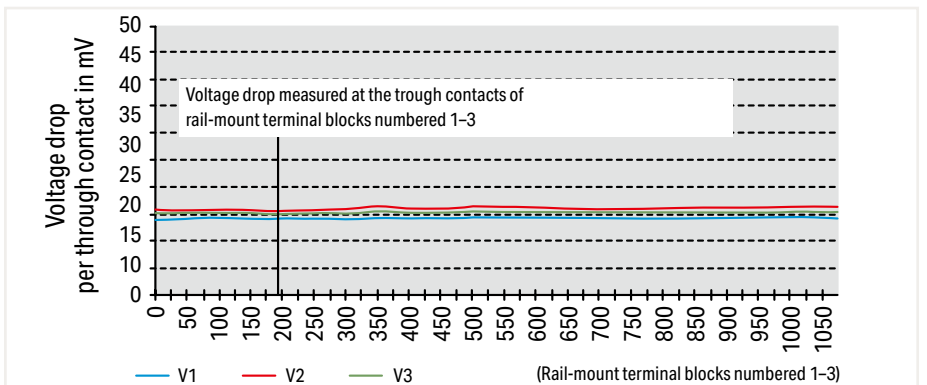
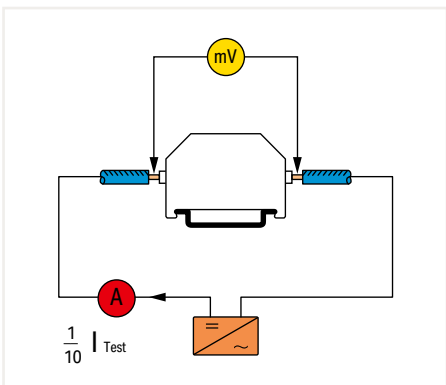

## Item Number Index

Item No.	Page	Item No.	Page	Item No.	Page	Item No.	Page
<b>249 Series</b>		<b>264 Series</b>		<b>279 Series</b>		<b>280 Series</b>	
249-125	28	264-317	35	279-837	3	280-552	11
249-126	28	264-321	35	279-837/999-950	3	280-554	21
249-127	28	264-324	35	279-838	3	280-555	21
		264-326	35	279-901	3	280-556	21
		264-327	35	279-902	3	280-557	11
		264-331	35	279-903	3	280-558	11
<b>260 Series</b>		264-334	35	279-904	3	280-560	20
260-102	37	264-336	35	279-905	3	280-560/281-434	20
260-112	37	264-337	35	279-906	3	280-562	21
260-202	37	264-341	35	279-907	3	280-562/281-411	21
260-212	37	264-344	35	279-907/999-950	3	280-562/281-420	21
260-301	37	264-346	35	279-992	3	280-562/281-434	21
260-303	37	264-347	35	279-993	3	280-564	20
260-304	37	264-351	35	279-994	3	280-564/281-483	20
260-306	37	264-354	35	279-995	3	280-570	20
260-307	37	264-356	35			280-570/281-434	20
260-331	37	264-357	35	<b>280 Series</b>		280-572	21
260-333	37	264-361	35	280-101	12	280-572/281-411	21
260-334	37	264-363	35	280-104	12	280-572/281-420	21
260-336	37	264-364	35	280-107	12	280-572/281-434	21
260-337	37	264-368	35	280-101	12	280-574	20
260-361	37	264-369	35	280-301	12	280-574/281-483	20
260-402	37	264-370	35	280-302	12	280-580	20
		264-402	35	280-303	11	280-580/281-434	20
<b>261 Series</b>		264-711	35	280-304	11	280-584	20
261-102	37	264-714	35	280-305	11	280-584/281-483	20
261-112	37	264-716	35	280-306	11	280-585	21
261-202	37	264-731	35	280-308	4	280-586	21
261-212	37	264-734	35	280-309	4	280-592	21
261-301	37	264-736	35	280-312	4	280-593	21
261-303	37	264-737	35	280-313	4	280-597	11
261-304	37	264-737/999-950	35	280-314	4	280-631	4
261-306	37			280-315	4	280-637	4
261-307	37	<b>279 Series</b>		280-319	20	280-637/999-950	4
261-331	37	279-101	12	280-320	20	280-640	4
261-333	37	279-104	12	280-321	20	280-646	4
261-334	37	279-308	3	280-323	20	280-650	4
261-336	37	279-325	3	280-324	4	280-651	4
261-337	37	279-328	3	280-326	4	280-653	4
261-361	37	279-330	3	280-340	10	280-654	4
261-402	37	279-339	3	280-341	10	280-656	4
		279-341	3	280-342	10	280-671	4
<b>262 Series</b>		279-344	3	280-343	10	280-672	4
262-102	37	279-346	3	280-352	4	280-681	4
262-112	37	279-348	3	280-354	4	280-684	4
262-202	37	279-402	28	280-356	4	280-687	4
262-212	37	279-409	28	280-358	4	280-687/999-950	4
262-301	37	279-415	28	280-371	14	280-830	4
262-304	37	279-422	28	280-373	14	280-831	4
262-306	37	279-470	28	280-374	14	280-832	4
262-307	37	279-471	28	280-376	14	280-833	4
262-331	37	279-482	28	280-402	20	280-834	4
262-334	37	279-483	28	280-404	28	280-835	4
262-336	37	279-490	28	280-409	28	280-837	4
262-337	37	279-492	28	280-415	28	280-837/999-950	4
262-361	37	279-501	10	280-418	28	280-838	4
262-402	37	279-504	10	280-419	28	280-868	14
		279-507	10	280-422	28	280-869	14
<b>264 Series</b>		279-508	10	280-470	20	280-870	14
264-102	35	279-509	10	280-471	20	280-871	14
264-112	35	279-512	10	280-472	20	280-874	14
264-125	35	279-513	10	280-482	28	280-875	14
264-130	35	279-517	10	280-483	28	280-876	14
264-131	35	279-518	10	280-490	28	280-879	14
264-152	35	279-519	10	280-492	28	280-880	14
264-162	35	279-527	10	280-517	10	280-881	14
264-180	35	279-681	3	280-519	10	280-882	14
264-202	35	279-682	3	280-520	10	280-883	14
264-212	35	279-683	3	280-523	10	280-884	14
264-225	35	279-684	3	280-524	10	280-885	14
264-230	35	279-685	3	280-527	10	280-901	4
264-231	35	279-686	3	280-529	10	280-902	4
264-252	35	279-687	3	280-530	10	280-903	4
264-262	35	279-687/999-950	3	280-533	10	280-904	4
264-280	35	279-826	3	280-534	10	280-905	4
264-301	35	279-831	3	280-537	10	280-906	4
264-304	35	279-832	3	280-547	11	280-907	4
264-306	35	279-833	3	280-548	11	280-907/999-950	4
264-307	35	279-834	3	280-549	11	280-946	4
264-311	35	279-835	3	280-550	11	280-992	4
264-314	35	279-836	3	280-551	11	280-993	4
264-316	35						



Item No.	Page	Item No.	Page	Item No.	Page	Item No.	Page
<b>280 Series</b>		<b>281 Series</b>		<b>282 Series</b>		<b>284 Series</b>	
280-994	4	281-623/281-541	18	282-387	15	284-101	12
280-996	4	281-624	18	282-390	15	284-104	12
280-998	4	281-629	10	282-391	15	284-107	12
		281-630	10	282-392	15	284-301	12
		281-631	5	282-402	28	284-302	12
		281-637	5	282-409	28	284-308	6
		281-637/999-950	5	282-422	28	284-325	6
		281-651	5	282-424	15	284-328	6
<b>281 Series</b>		281-652	5	282-432/100-000	15	284-330	6
281-101	12	281-653	5	282-433/100-000	15	284-339	6
281-104	12	281-654	5	282-434/100-000	15	284-341	6
281-107	12	281-656	19	282-638	14	284-400	32
281-301	12	281-657	5	282-639	14	284-402	28
281-302	12	281-657/999-950	5	282-640	14	284-409	28
281-309	18	281-658	5	282-641	14	284-412	8
281-311	18	281-663	5	282-681	6	284-413	7
281-312	5	281-664	5	282-682	6	284-414	7
281-313	5	281-668	5	282-684	6	284-415	28
281-324	5	281-672	18	282-687	6	284-422	28
281-326	5	281-678	5	282-687/999-950	6	284-621	8
281-328	5	281-679	5	282-694	14	284-624	8
281-329	5	281-681	5	282-695	14	284-681	6
281-334	5	281-684	5	282-696	18	284-682	6
281-335	5	281-685	5	282-697	14	284-684	6
281-340	10	281-686	5	282-698/281-413	18	284-687	6
281-341	10	281-687	5	282-698/281-429	18	284-687/999-950	6
281-342	10	281-687/999-950	5	282-698/281-434	18	284-901	6
281-343	10	281-901	5	282-698/281-449	18	284-902	6
281-345	5	281-902	5	282-699	14	284-904	6
281-349	5	281-903	5	282-811	15	284-907	6
281-355	5	281-904	5	282-821	15	284-907/999-950	6
281-357	5	281-905	5	282-841	15	284-992	6
281-365	11	281-906	5	282-841/049-000	15	284-993	6
281-366	11	281-907	5	282-860	15		
281-402	28	281-907/999-950	5	282-865	15		
281-407	28	281-916	19	282-866	15	<b>285 Series</b>	
281-409	28	281-992	5	282-868	15	285-435	7
281-415	28	281-993	5	282-870	15	285-634	7
281-418	28	281-994	5	282-901	6	285-635	7
281-419	28	281-998	5	282-902	6	285-637	7
281-421	28			282-904	6	285-637/999-950	7
281-422	28	<b>282 Series</b>		282-907	6	285-992	7
281-470	28	282-101	12	282-907/999-950	6		
281-471	28	282-104	12	282-992	6	<b>294 Series</b>	
281-472	28	282-107	12	282-993	6	294-4002	41
281-482	28	282-120	13			294-4003	41
281-483	28	282-122	13	<b>283 Series</b>		294-4004	41
281-485	28	282-124	13	283-101	12	294-4005	41
281-490	28	282-126	13	283-104	12	294-4006	41
281-492	28	282-128	13	283-107	12	294-4007	41
281-511	19	282-128/281-413	13	283-107	12	294-4012	41
281-512	19	282-128/281-417	13	283-301	12	294-4013	41
281-512/281-417	19	282-128/281-418	13	283-302	12	294-4014	41
281-512/281-418	19	282-131	13	283-325	7	294-4015	41
281-512/281-501	19	282-133	13	283-328	7	294-4022	41
281-530	11	282-135	13	283-330	7	294-4023	41
281-531	11	282-137	13	283-350	7	294-4024	41
281-532	11	282-138	13	283-352	7	294-4025	41
281-611	18	282-139	13	283-354	7	294-4032	41
281-611/281-417	18	282-140	13	283-400	28	294-4035	41
281-611/281-418	18	282-141	13	283-402	28	294-4042	41
281-611/281-541	18	282-301	12	283-409	28	294-4043	41
281-611/281-542	18	282-302	12	283-414	7	294-4044	41
281-612	18	282-308	6	283-415	28	294-4045	41
281-612/281-417	18	282-311	13	283-422	28	294-4052	41
281-612/281-418	18	282-312	13	283-671	7	294-4053	41
281-612/281-541	18	282-314	13	283-672	7	294-4055	41
281-612/281-542	18	282-315	13	283-674	7	294-4072	41
281-613	18	282-325	6	283-677	7	294-4075	41
281-613/281-417	18	282-328	6	283-677/999-950	7	294-4094/4025-000	41
281-613/281-418	18	282-330	6	283-901	7	294-4095/5025-000	41
281-613/281-541	18	282-333	18	283-902	7	294-4095/5026-000	41
281-613/281-542	18	282-334	18	283-904	7	294-4095/5027-000	41
281-616	18	282-339	6	283-907	7	294-4153	41
281-619	10	282-341	6	283-907/999-950	7	294-4213	41
281-620	10	282-360	15	283-992	7	294-4214	41
281-622	18	282-361	15	283-998	7	294-4215	41
281-622/281-417	18	282-365	15			294-4223	41
281-622/281-418	18	282-366	15			294-4224	41
281-622/281-541	18	282-385	15			294-4225	41
281-622/281-542	18	282-386	15			294-4235	41
281-623	18						
281-623/281-417	18						
281-623/281-418	18						

## Item Number Index

Item No.	Page	Item No.	Page	Item No.	Page	Item No.	Page
<b>294 Series</b>		<b>726 Series</b>		<b>769 Series</b>		<b>811 Series</b>	
294-4253	41	726-632	30	769-208/281-410	25	811-310	19
294-4255	41	726-721	30	769-208/281-411	25	811-311	19
294-4275	41	726-741	30	769-209/281-413	25	811-314	19
294-4313	41	726-821	30	769-209/281-434	25	811-316	19
294-4314	41	726-841	30	769-211	23	811-317	19
294-4315	41			769-212	24	811-320	19
294-4323	41			769-213	24	811-321	19
294-4324	41	<b>727 Series</b>		769-214	23	811-330	19
294-4325	41	727-113	31	769-217	23	811-331	19
294-4335	41	727-117	31	769-218/281-410	25	811-410	19
294-4353	41	727-119	31	769-218/281-411	25	811-411	19
294-4355	41	727-120	31	769-219/281-413	25	811-414	19
294-4375	41	727-121	31	769-219/281-434	25	811-420	19
294-4413	41	727-122	31	769-221	23	811-421	19
294-4414	41	727-123	31	769-222	24	811-430	19
294-4415	41	727-124	31	769-223	24	811-431	19
294-4423	41	727-125	31	769-227	23	811-472	19
294-4424	41	727-126	31	769-228/281-410	25	811-482	19
294-4425	41	727-127	31	769-228/281-411	25		
294-4435	41	727-128	31	769-229/281-413	25	<b>812 Series</b>	
294-4455	41	727-129	31	769-229/281-434	25	812-100	32
294-4475	41	727-130	31	769-231	23	812-101	32
294-5002	40	727-131	31	769-232	24	812-102	32
294-5003	40	727-132	31	769-233	24	812-103	32
294-5004	40	727-133	31	769-237	23	812-104	32
294-5012	40	727-134	31	769-238/281-410	25	812-110	32
294-5013	40	727-135	31	769-238/281-411	25	812-111	32
294-5022	40	727-136	31	769-239/281-413	25	812-112	32
294-5023	40	727-137	31	769-239/281-434	25	812-113	32
294-5024	40	727-138	31	769-251	23	812-114	32
294-5032	40	727-213	31	769-251/000-006	23	812-140	32
294-5042	40	727-217	31	769-257	23	812-141	32
294-5043	40	727-219	31	769-301	23		
294-5052	40	727-220	31	769-302	23	<b>862 Series</b>	
294-5053	40	727-221	31	769-303	23	862-503	38
294-5072	40	727-222	31	769-304	23	862-504	38
294-5113	40	727-223	31	769-305	23	862-505	38
294-5123	40	727-224	31	769-306	23	862-515	39
294-5124	40	727-225	31	769-307	23	862-525	39
294-5153	40	727-226	31	769-308	23	862-532	39
294-5213	40	727-227	31	769-309	24	862-533	39
294-5223	40	727-228	31	769-310	24	862-534	39
294-5224	40	727-229	31	769-311	24	862-552	38
294-5253	40	727-230	31	769-312	24	862-562	39
294-5313	40	727-231	31	769-315	23	862-593	39
294-5323	40	727-232	31	769-316	23	862-594	39
294-5324	40	727-233	31	769-320	23	862-603	38
294-5353	40	727-234	31	769-321	23	862-604	38
294-5413	40	727-235	31	769-410	27	862-605	38
294-5423	40	727-236	31	769-411	27	862-615	39
294-5424	40	727-237	31	769-412	27	862-625	39
		727-238	31	769-413	27	862-632	39
				769-414	27	862-633	39
				769-428	27	862-634	39
<b>709 Series</b>		<b>769 Series</b>		769-429	27	862-652	38
709-310	28	769-101	27	769-430	27	862-662	39
709-311	28	769-101/022-000	27	769-431	27	862-693	39
		769-102	27	769-435	27	862-694	39
<b>726 Series</b>		769-102/022-000	27	769-470	27	862-1503	38
726-121	30	769-103	27	769-471	27	862-1503/999-950	38
726-122	30	769-103/022-000	27	769-472	27	862-1504	38
726-141	30	769-115	27			862-1504/999-950	38
726-142	30	769-115/022-000	27			862-1505	38
726-221	30	769-121	27			862-1505/999-950	38
726-222	30	769-122	27	<b>780 Series</b>		862-1515	39
726-241	30	769-123	27	780-452	28	862-1515/999-950	39
726-242	30	769-135	27	780-453	28	862-1525	39
726-321	30	769-151	23	780-454	28	862-1525/999-950	39
726-322	30	769-156	23	780-455	28	862-1532	39
726-341	30	769-1602	27	780-456	28	862-1532/999-950	39
726-342	30	769-1605	27	780-457	28	862-1533	39
726-421	30	769-1606	27	780-458	28	862-1533/999-950	39
726-441	30	769-1615	27			862-1534	39
726-521	30	769-171	23	<b>781 Series</b>		862-1534/999-950	39
726-541	30	769-171/000-006	23	781-452	28	862-1552	38
726-601	30	769-176	23	781-453	28	862-1552/999-950	38
726-602	30	769-176/000-006	23	781-454	28	862-1562	39
726-611	30	769-176/000-012	23	781-455	28	862-1562/999-950	39
726-612	30	769-201	23	781-456	28	862-1593	39
726-621	30	769-202	24			862-1593/999-950	39
726-622	30	769-203	24			862-1594	39
726-631	30	769-207	23				

Item No.	Page	Item No.	Page	Item No.	Page	Item No.	Page
<b>862 Series</b>		<b>862 Series</b>					
862-1594/999-950	39	862-9633	39				
862-1603	38	862-9634	39				
862-1603/999-950	38	862-9693	39				
862-1604	38	862-9694	39				
862-1604/999-950	38						
862-1605	38	<b>870 Series</b>					
862-1605/999-950	38	870-101	26				
862-1615	39	870-102	26				
862-1615/999-950	39	870-103	26				
862-1625	39	870-104	26				
862-1625/999-950	39	870-117	26				
862-1632	39	870-118	26				
862-1632/999-959	39	870-119	26				
862-1633	39	870-127	26				
862-1633/999-950	39	870-131	26				
862-1634	39	870-137	26				
862-1634/999-950	39	870-138	26				
862-1652	38	870-148	26				
862-1652/999-950	38	870-149	26				
862-1662	39	870-151	26				
862-1662/999-950	39	870-157	26				
862-1693	39	870-158	26				
862-1693/999-950	39	870-168	26				
862-1694	39	870-169	26				
862-1694/999-950	39	870-1131	26				
862-2503	38	870-1137	26				
862-2504	38	870-1138	26				
862-2505	38	870-1148	26				
862-2515	39	870-1149	26				
862-2525	39						
862-2532	39						
862-2533	39						
862-2534	39						
862-2552	38						
862-2562	39						
862-2593	39						
862-2594	39						
862-2603	38						
862-2604	38						
862-2605	38						
862-2615	39						
862-2625	39						
862-2632	39						
862-2633	39						
862-2634	39						
862-2652	38						
862-2662	39						
862-2693	39						
862-2694	39						
862-8503	38						
862-8504	38						
862-8505	38						
862-8515	39						
862-8525	39						
862-8533	39						
862-8534	39						
862-8593	39						
862-8594	39						
862-8603	38						
862-8604	38						
862-8605	38						
862-8615	39						
862-8625	39						
862-8633	39						
862-8634	39						
862-8693	39						
862-8694	39						
862-9503	38						
862-9504	38						
862-9505	38						
862-9515	39						
862-9525	39						
862-9533	39						
862-9534	39						
862-9593	39						
862-9594	39						
862-9603	38						
862-9604	38						
862-9605	38						
862-9615	39						
862-9625	39						

**WAGO GmbH & Co. KG**

Postfach 2880 · D · 32385 Minden  
Hansastraße 27 · D · 32423 Minden

[info@wago.com](mailto:info@wago.com)

[www.wago.com](http://www.wago.com)

Headquarters	+49 571 887 - 0
Sales	+49 571 887 - 44222
Order Service	+49 571 887 - 44333

Current addresses at [www.wago.com](http://www.wago.com)

WAGO is a registered trademark of WAGO Verwaltungsgesellschaft mbH.

"Copyright – WAGO GmbH & Co. KG – All rights reserved.

The content and structure of the WAGO websites, catalogs, videos and other WAGO media are subject to copyright. Distribution or modification to the contents of these pages and videos is prohibited. Furthermore, the content may neither be copied nor made available to third parties for commercial purposes. Also subject to copyright are the images and videos that were made available to WAGO GmbH & Co. KG by third parties."