

Nízkoložný návěsový podvalník

Goldhofer STN-L3, 1:14

Stavebnice

Obj. č.: 23 34 35



Vážení zákazníci,

děkujeme Vám za Vaši důvěru a za nákup stavebnice nízkoložného návěsového podvalníku Carson Goldhofer.

Předtím než přistoupíte k sestavování stavebnice, si pozorně prostudujte celý návod. Abyste se vyhnuli problémům a sestavili dokonalý model, musíte v jednotlivých krocích postupovat přesně podle návodu.

Potřebné nářadí



Malý šroubovák



Lámací modelářský nůž



Imbusový klíč



Prodloužené kleště



Štípací kleště



Nástrčný klíč

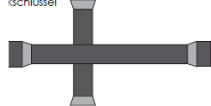

Sekundové lepidlo



Mazivo

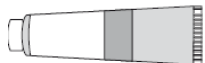

A 1 - 4
SÁČEK A

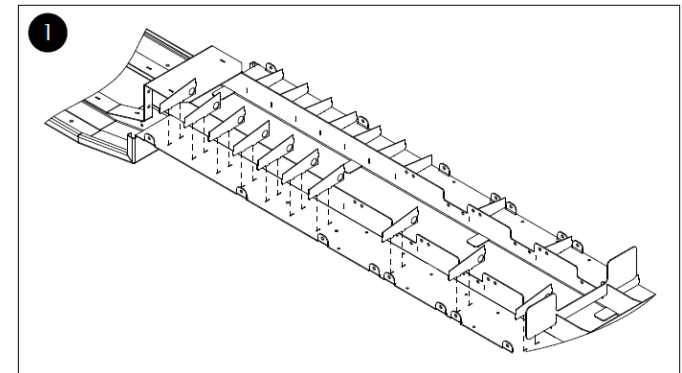

Matice 3 mm



AA3 x 18

Podložka 3 mm



AF1 x 12

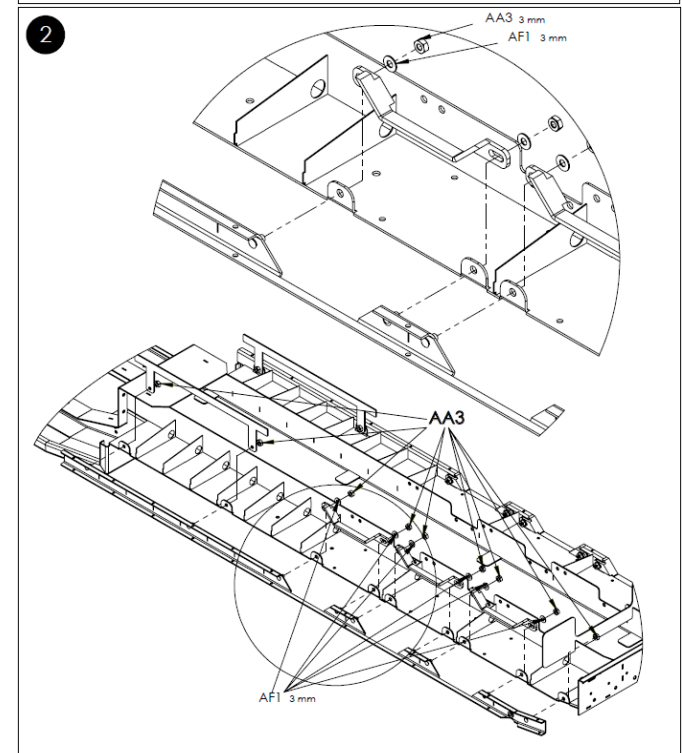

Šroub 3 x 6 mm



Matice 3 mm



AA3 x 4

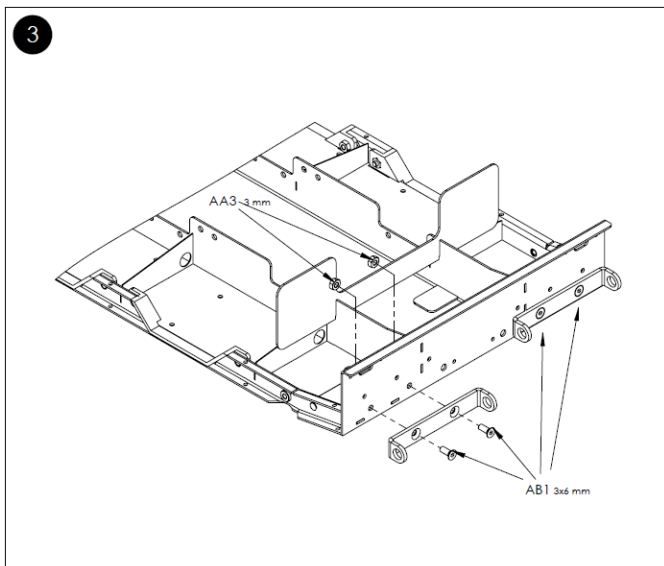

Matice 2 mm



Šroub 3 x 16 mm

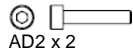

AD2 x 2

Šroub 2 x 8 mm



AE4 x 6

Matice 3 mm



AA3 x 2

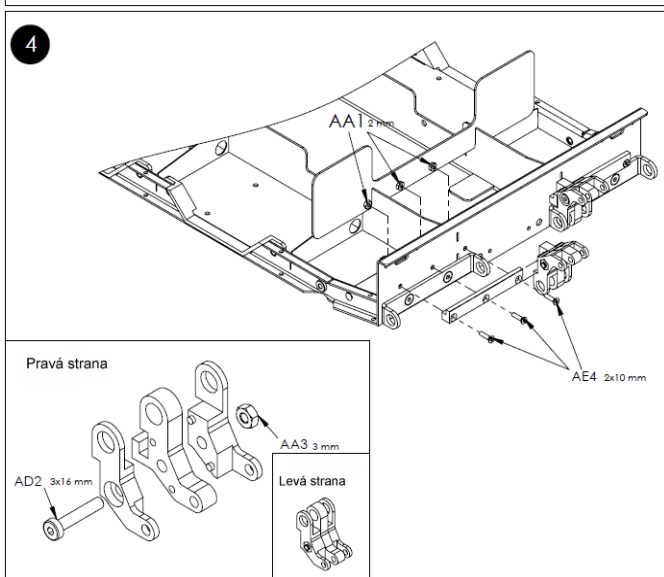

B 5 - 13
Sáček B

Samořezný šroub
2,2 x 6,5 mm

AJ1 x 18

Kuličkové ložisko



AM 1 x 12

Rada:
K přilepení
pneumatik použijte
vteřinové lepidlo
(není součástí
dodávky).

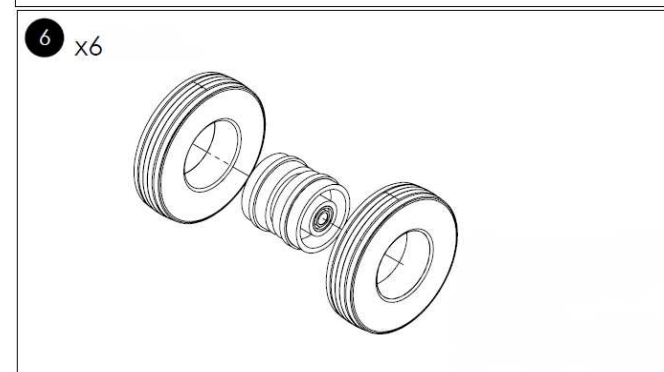
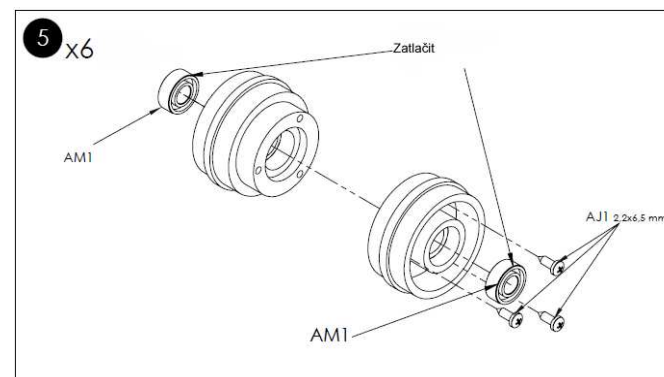

Matice 2 mm

AA1 x 12

Šroub 3 x 14 mm

AC1 x 6

Pojistná matice
3 mm

AA4 x 6

Ocelová průchodka
5 x 8 mm

AK1

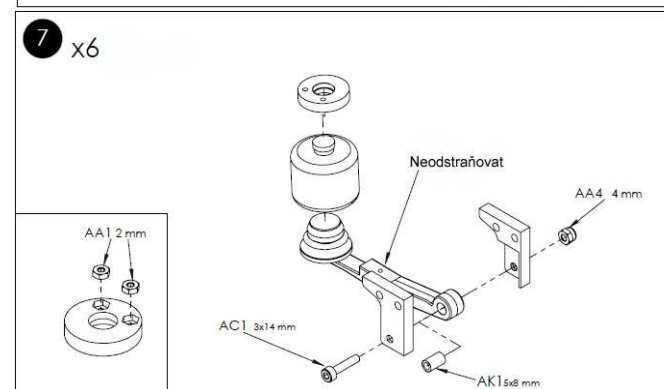

Matice 2,6 mm



AA2 x 24

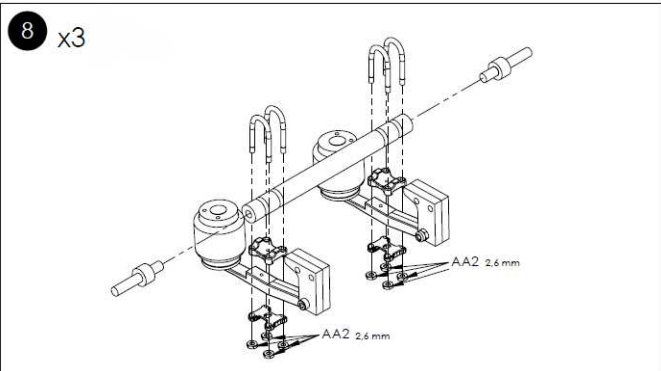

Pojistná matice
5 mm



AA5 x 6

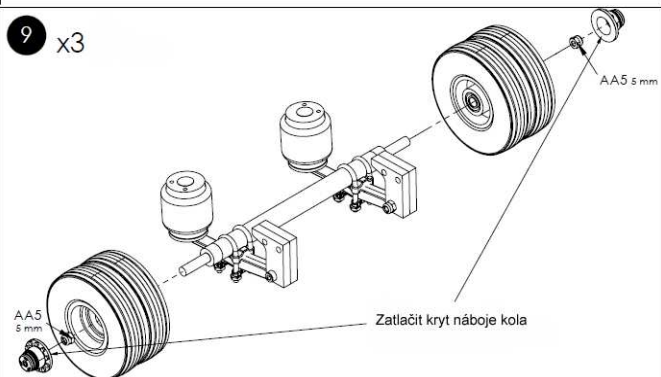

Šroub 2 x 5 mm



AC3 x 12

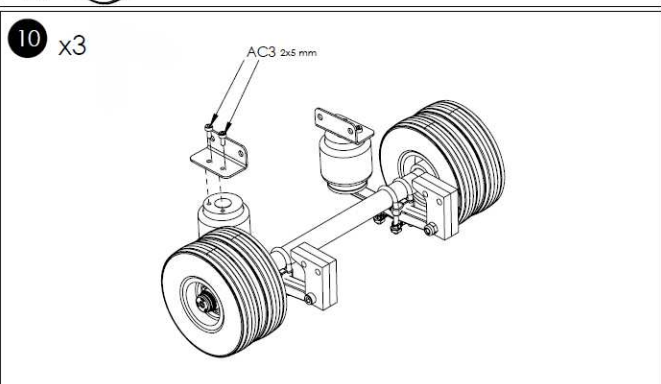

Šroub 3 x 8 mm



AB2 x 2

Šroub 3 x 4 mm



AC2 x 4

Šroub 3 x 8 mm



AB2 x 2

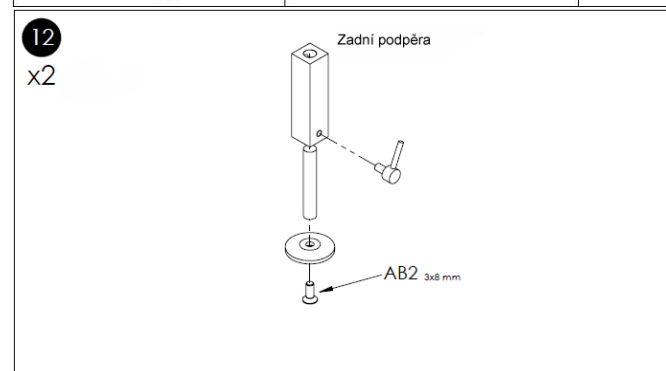
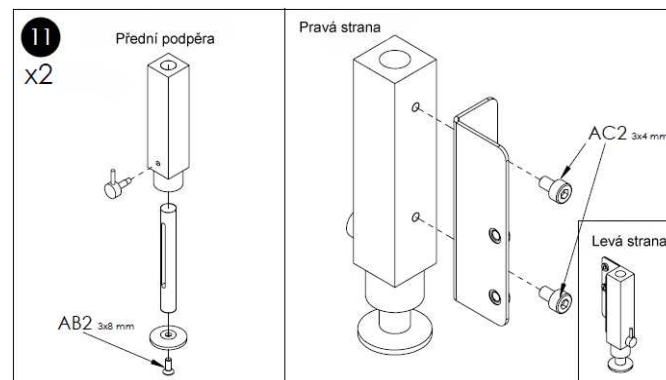

Produkt č.
500907071

Alternativa:
Sada světel 7 -
zadní světla

Vhodné pro
(Tamiya MFC01)

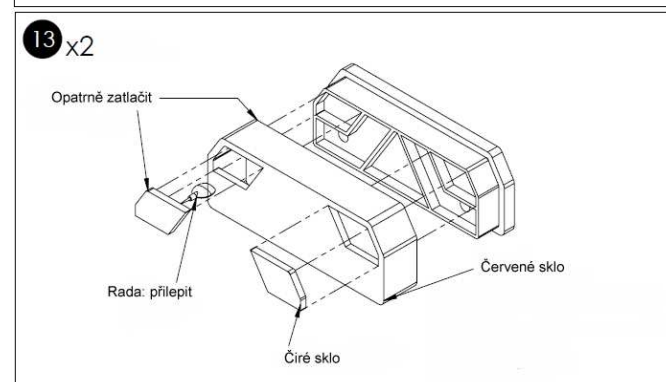

C 14 - 19
SÁČEK C

⊕
AE2 x 4

Matice 2 mm

⊕
AA1 x 2

Šroub 2 x 6 mm

⊕
AE3 x 2

Podložka 3 mm

⊕
AF1 x 4

Šroub 3 x 4 mm

⊕
AC2 x 4

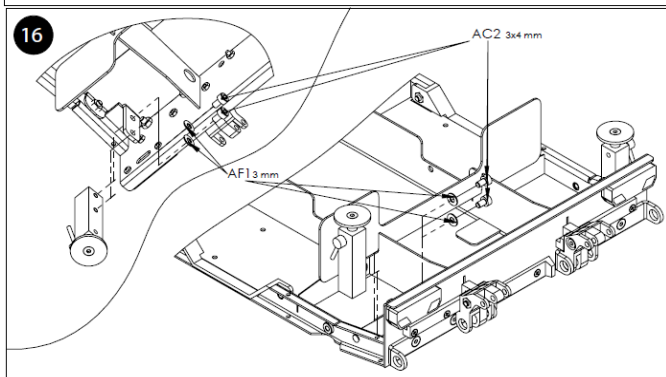
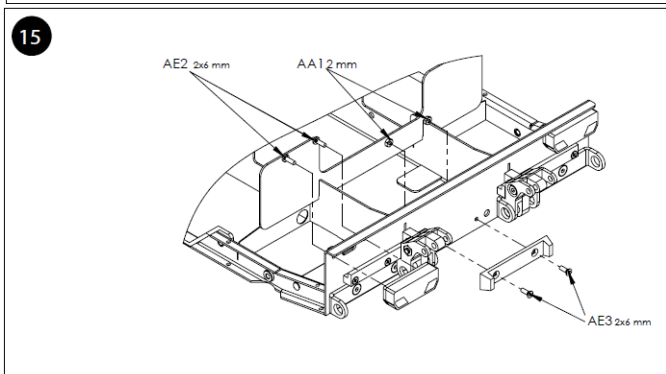
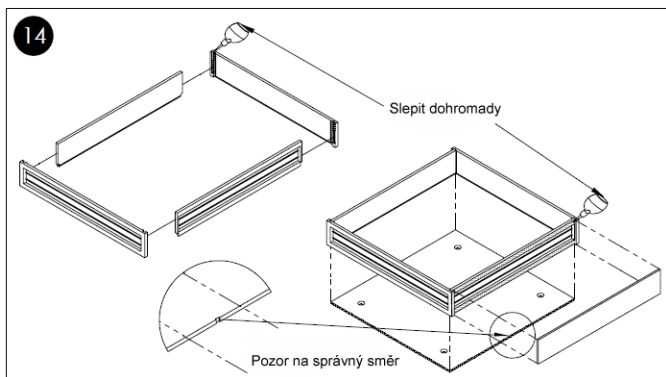

Šroub 3 x 6 mm

⊕
AC4 x 4

Šroub 3 x 16 mm

⊕
AB3 x 1

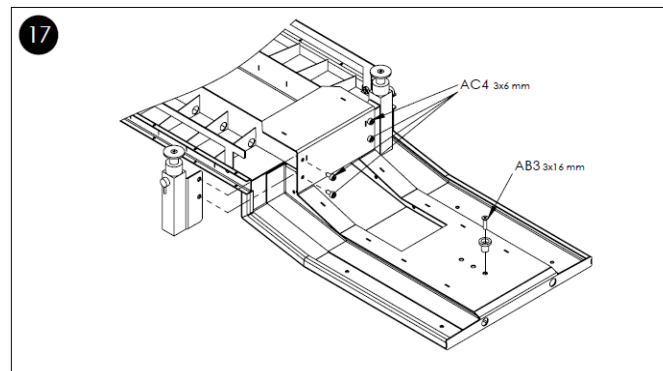

Šroub 3 x 14 mm

⊕
AC1 x 12

Matice 3 mm

⊕
AA3 x 24

Šroub 3 x 6 mm

⊕
AC4 x 12

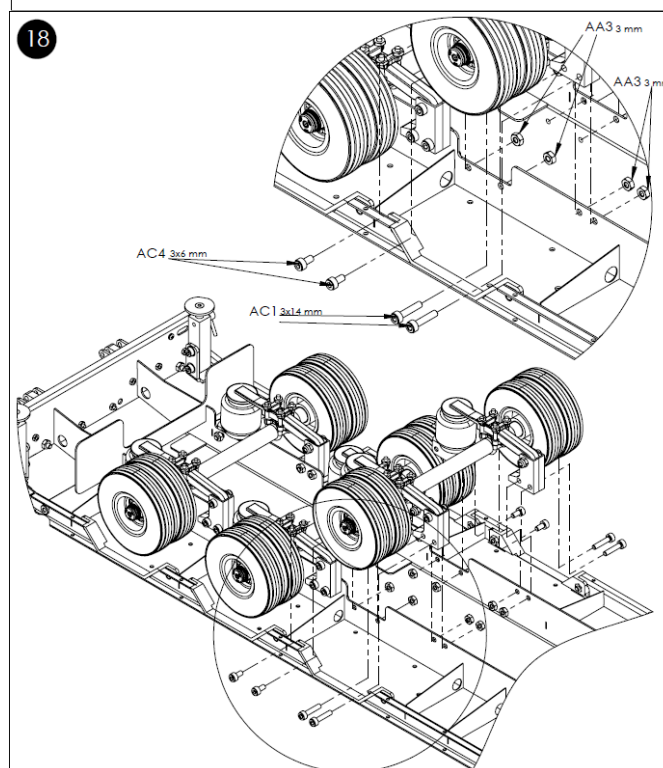

Šroub 3 x 6 mm



AB1 x 4

Matice 3 mm



AA3 x 2

D 20 - 33
SÁČEK D

Šroub 3 x 6 mm



AB1 x 4

Šroub 3 x 6 mm



AD1 x 4

Šroub 3 x 6 mm



A11 x 2



Šroub 2 x 12 mm

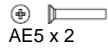

AE5 x 2



x2



x2



x2

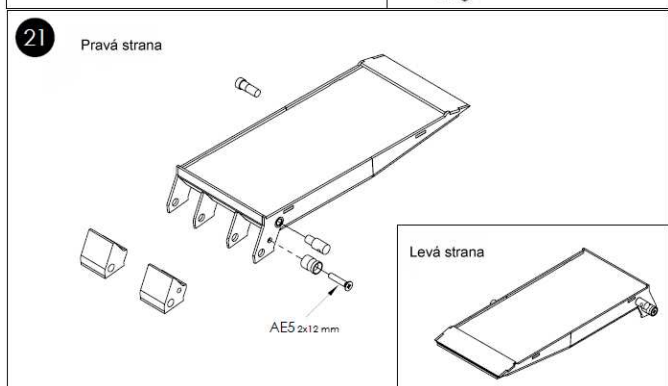
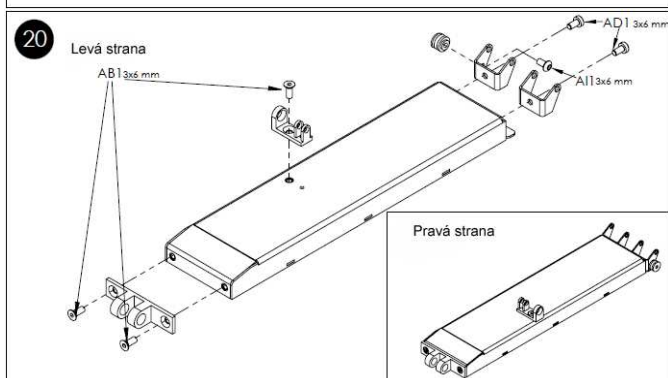
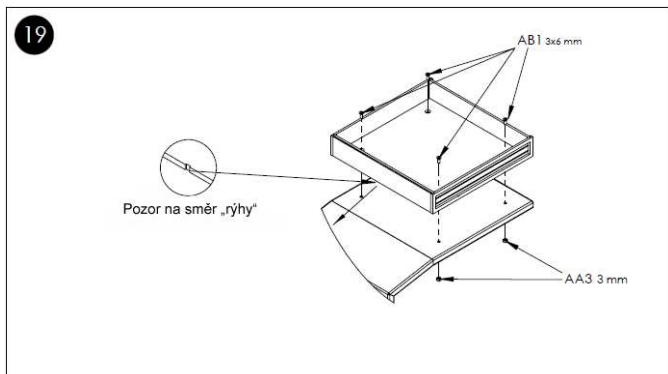

Pojistný kroužek
2,3 mm



AG1 x 4



x 4

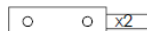

x 2

Válcový kolík 2 x 8
mm



AH1 x 4

Pojistný kroužek
2,3 mm



AG2 x 2

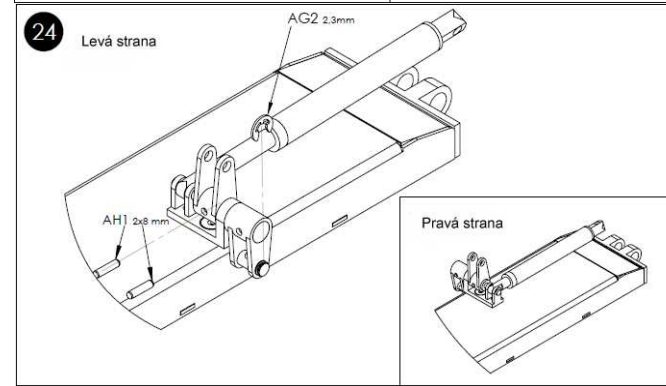
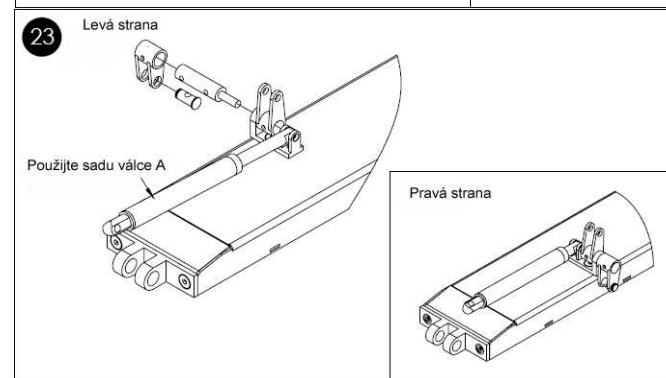
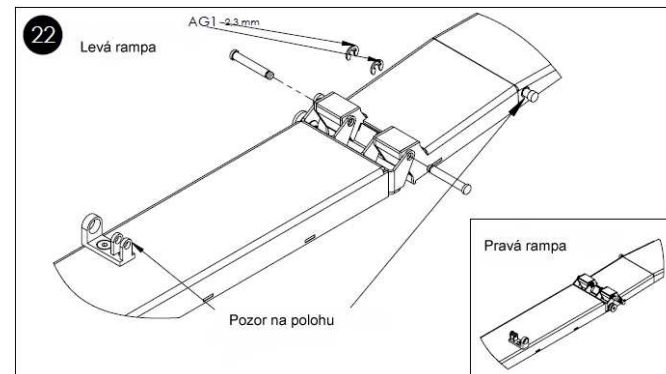

Pojistný kroužek
2,3 mm



AG1 x 2

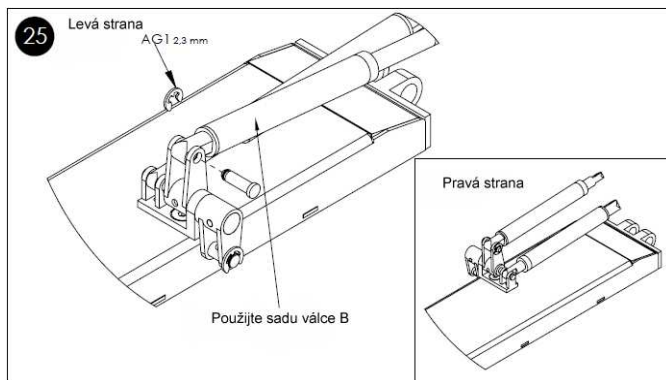
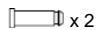

Pojistný kroužek
4 mm



AG4 x 4

** viz níže

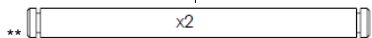
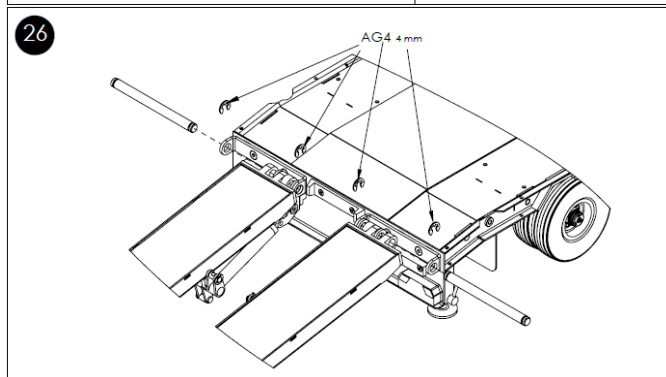

Pojistný kroužek
2,3 mm



AG1 x 2

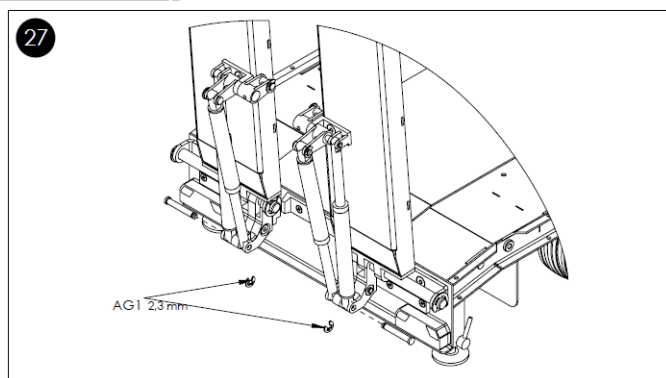

28 x2

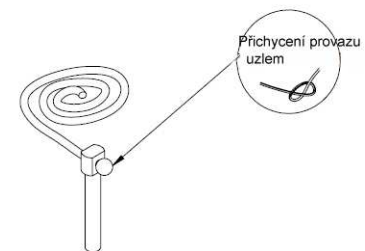

29 x2

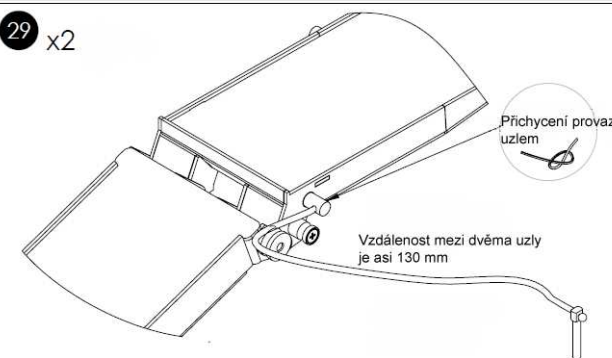

Matice 2 mm



AA1 x 2

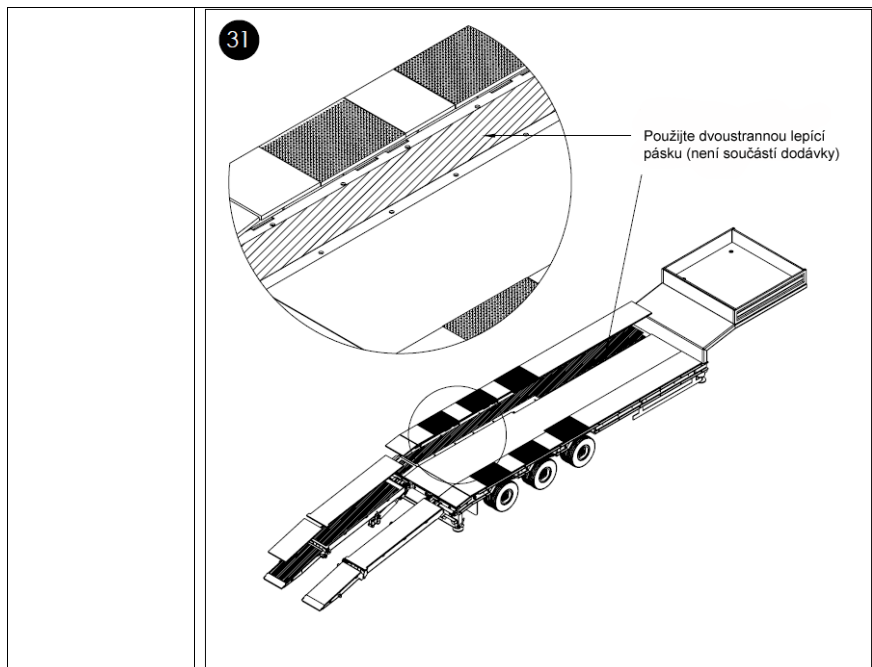
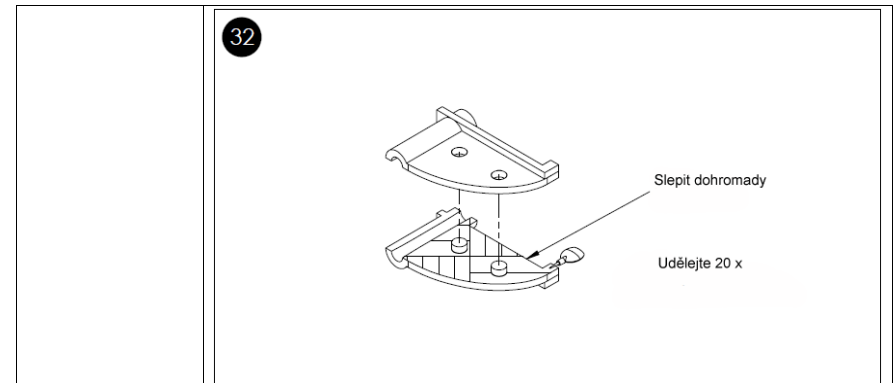
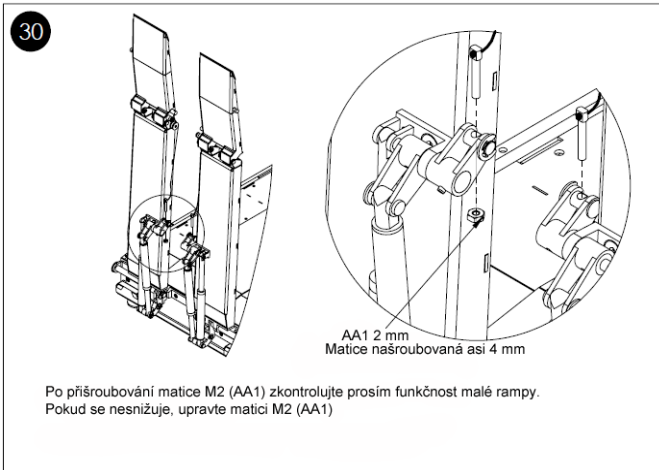

Válcový kolík
2 x 16 mm
 AH2 x 20
 x 2

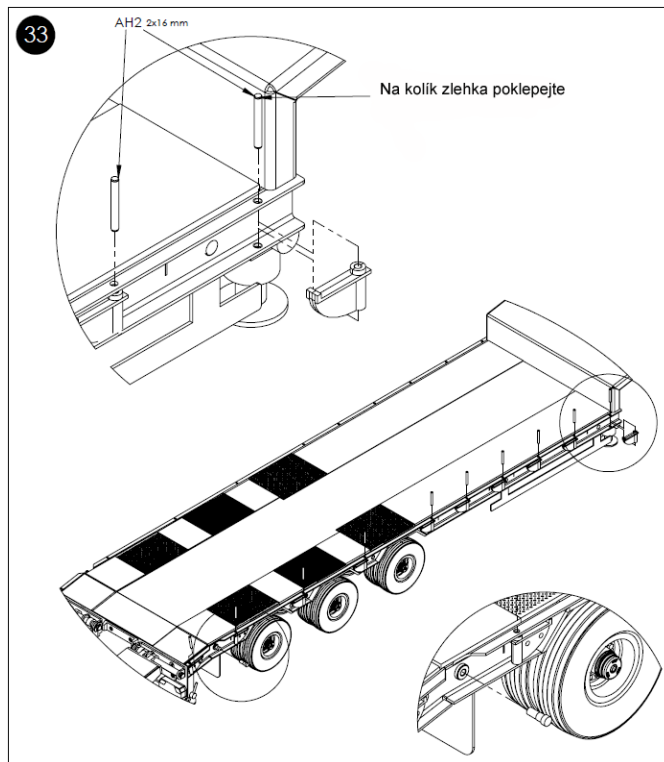

Recyklace



Likviduje odpad na konci doby životnosti výrobku přiměřeně podle platných zákonných ustanovení.

Šetřete životní prostředí! Přispějte k jeho ochraně!

Příklad tohoto návodu zajišťuje společnost Conrad Electronic Česká republika, s. r. o.

Všechna práva vyhrazena. Jakékoliv druhy kopií tohoto návodu, jako např. fotokopie, jsou předmětem souhlasu společnosti Conrad Electronic Česká republika, s. r. o. Návod k použití odpovídá technickému stavu při tisku! **Změny vyhrazeny!**

© Copyright Conrad Electronic Česká republika, s. r. o.

VAL/3/2014