

LDP3- 12- 24DC

Obj.č.: 2833770



<http://eshop.phoenixcontact.cz/phoenix/treeViewClick.do?UID=2833770>

Zásuvný modul, k osazení na PR3, s diodou na ochranu proti přepětí a žlutou LED diodou, polarita: **A1+**, **A2-**, vstupní napětí: 12-24 V DC ± 20%

Údaje	
EAN	 4 017918 933968
Balení	10 ks
Celní tarif	85366990
Váha brutto v kusech	0,0065 kg
Informace v katalogu	Strana 388 (CAT-7-2013)

Poznámky k produktu

WEEE/RoHS-compliant since:
01.03.2006



<http://www.download.phoenixcontact.com>
Please note that the data given here has been taken from the online catalog. For comprehensive information and data, please refer to the user documentation. The General Terms and Conditions of Use apply to Internet downloads.

Certifikáty/Osvědčení



Aprobace

cULus Recognized

Vyžádané aprobace:

Aprobace z:

Výkres/schéma

Schéma zapojení

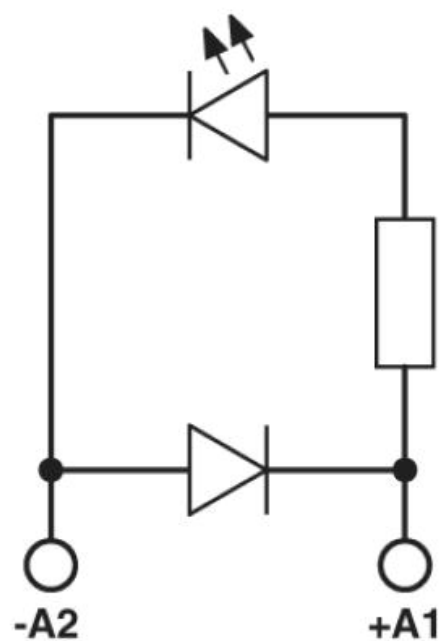

Adresa

PHOENIX CONTACT, s.r.o.
Dornych 47
617 00 Brno, Czech Republic
Telefon +420 542 213 401
Fax +420 542 213 701
<http://www.phoenixcontact.cz>



© 2013 Phoenix Contact
Technické změny vyhrazeny.