

Relaissockel - PLC-BSC-120UC/21/SO46 - 2980319

Bitte beachten Sie, dass die hier angegebenen Daten dem Online-Katalog entnommen sind. Die vollständigen Informationen und Daten entnehmen Sie bitte der Anwenderdokumentation. Es gelten die Allgemeinen Nutzungsbedingungen für Internet-Downloads. (<http://download.phoenixcontact.de>)



6,2 mm PLC-Grundklemmen mit Schraubanschluss und integriertem RCZ-Filter gegen Störströme bzw. Störspannungen auf der Steuerseite, Eingangsspannung 120 V AC (ohne Relais- oder Optokopplerbestückung)

Produkteigenschaften

- Unempfindlich gegen Störströme
- Hohe Relaisrückfallspannung



Kaufmännische Daten

Verpackungseinheit	10
GTIN	4017918895709

Technische Daten

Hinweis:

Nutzungsbeschränkung	EMV: Klasse-A-Produkt, siehe Herstellererklärung im Downloadbereich
-----------------------------	---

Maße

Breite	6,2 mm
Höhe	80 mm
Tiefe	94 mm

Umgebungsbedingungen

Umgebungstemperatur (Betrieb)	-25 °C ... 55 °C
Umgebungstemperatur (Lagerung/Transport)	-40 °C ... 85 °C

Eingangsdaten

Eingangsnennspannung U_N	120 V AC
Statusanzeige	LED
Schutzbeschaltung	Brückengleichrichter Brückengleichrichter
Schutzbeschaltung	RCZ-Filter RCZ-Filter

Ausgangsdaten

Mögliche Bestückung	Miniaturrelais, REL-MR-60DC/21AU, REL-MR-60DC/21; Miniatureoptokoppler, OPT-60DC/48DC/100, OPT-60DC/24DC/2, OPT-60DC/230AC/1
----------------------------	--

Relaissockel - PLC-BSC-120UC/21/SO46 - 2980319

Technische Daten

Anschlussdaten

Leiterquerschnitt starr min	0,14 mm ²
Leiterquerschnitt starr max	2,5 mm ²
Leiterquerschnitt flexibel min	0,14 mm ²
Leiterquerschnitt flexibel max	2,5 mm ²
Leiterquerschnitt AWG/kcmil min	26
Leiterquerschnitt AWG/kcmil max	14
Anschlussart	Schraubanschluss
Abisolierlänge	8 mm
Schraubengewinde	M3

Allgemein

Farbe	grün
Betriebsart	100 % ED
Brennbarkeitsklasse nach UL 94	V0
Einbaulage	beliebig
Montagehinweis	anreihbar ohne Abstand

Klassifikationen

eCl@ss

eCl@ss 4.0	27371102
eCl@ss 4.1	27371102
eCl@ss 5.0	27371603
eCl@ss 5.1	27371603
eCl@ss 6.0	27371603
eCl@ss 7.0	27371603
eCl@ss 8.0	27371603

ETIM

ETIM 2.0	EC001456
ETIM 3.0	EC001456
ETIM 4.0	EC001456
ETIM 5.0	EC001456

UNSPSC

UNSPSC 6.01	30211917
UNSPSC 7.0901	39121516
UNSPSC 11	39121516
UNSPSC 12.01	39121516
UNSPSC 13.2	39121516

Relaissockel - PLC-BSC-120UC/21/SO46 - 2980319

Approbationen

UL Recognized / cUL Recognized / GL / cULus Recognized /

Approbationsdetails

UL Recognized 

cUL Recognized 

GL

cULus Recognized  US

Zubehör

Tragschiene

NS 35/ 7,5 V2A UNPERF 2000MM - 0801377



NS 35/ 7,5 PERF 2000MM - 0801733



NS 35/ 7,5 CU UNPERF 2000MM - 0801762



Relaissockel - PLC-BSC-120UC/21/SO46 - 2980319

Zubehör

NS 35/15 UNPERF 2000MM - 1201714



NS 35/15 CU UNPERF 2000MM - 1201895



NS 35/15-2,3 UNPERF 2000MM - 1201798



NS 35/15 AL UNPERF 2000MM - 1201756



NS 35/15 PERF 2000MM - 1201730



Relaissockel - PLC-BSC-120UC/21/SO46 - 2980319

Zubehör

NS 35/ 7,5 UNPERF 2000MM - 0801681



Klemmenmarker unbeschriftet

ZB 6:UNBEDRUCKT - 1051003



ZB 6/WH-100:UNBEDRUCKT - 5060935



Klemmenmarker beschriftet

ZB 6,LGS:FORTL.ZAHLEN - 1051016



Trennplatte

PLC-ATP BK - 2966841



Relaissockel - PLC-BSC-120UC/21/SO46 - 2980319

Zubehör

Einspeisemodul

PLC-ESK GY - 2966508



Schraubwerkzeug

SZF 1-0,6X3,5 - 1204517



Anschaltmodul

PLC-V8/FLK14/IN - 2296553



PLC-V8/FLK14/IN/M - 2304115



PLC-V8/D15B/IN - 2296087



Relaissockel - PLC-BSC-120UC/21/SO46 - 2980319

Zubehör

Übergabemodul

PLC-V8/D15S/IN - 2296074



Brücke

FBST 500-PLC RD - 2966786



FBST 500-PLC BU - 2966692



FBST 500-PLC GY - 2966838



FBST 6-PLC RD - 2966236



Relaissockel - PLC-BSC-120UC/21/SO46 - 2980319

Zubehör

FBST 6-PLC BU - 2966812



FBST 6-PLC GY - 2966825



FBST 8-PLC GY - 2967688



Zeichnungen

Applikationszeichnung

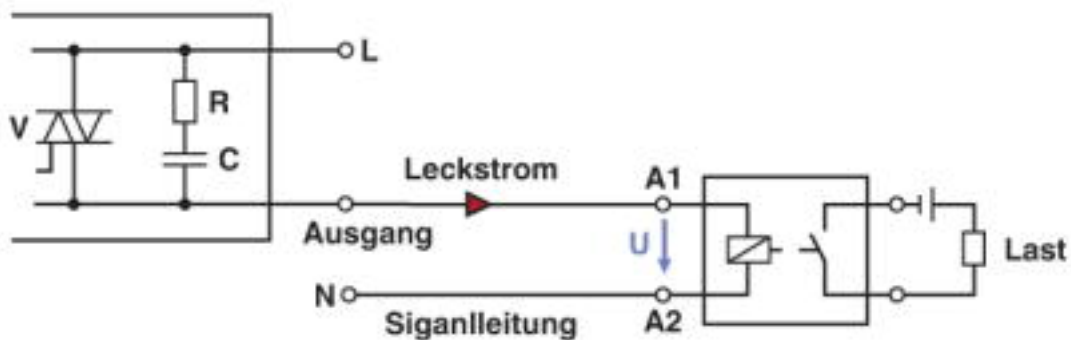

Entstehung von Störsignalen Fall 1: Steuerung - AC-Ausgangskarte

Relaissockel - PLC-BSC-120UC/21/SO46 - 2980319

Applikationszeichnung

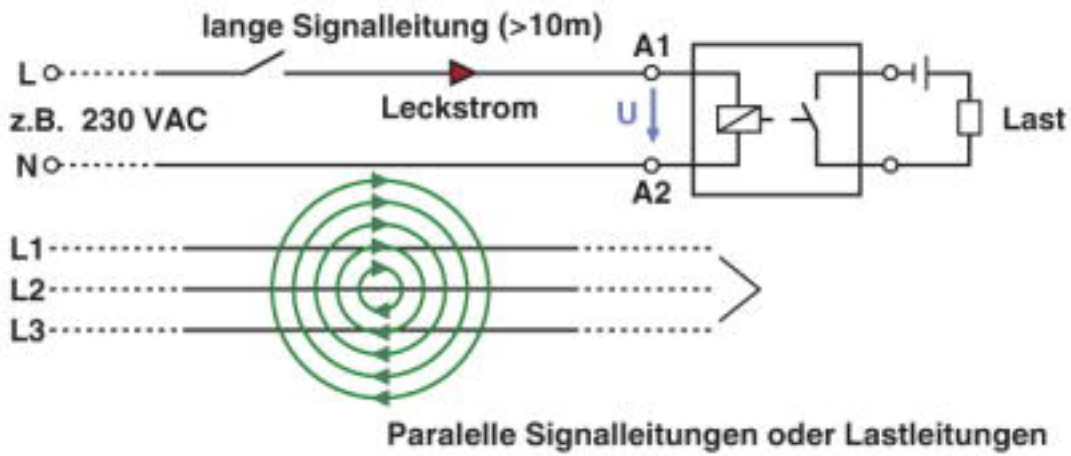

Entstehung von Störsignalen Fall 2: lange Signalleitungen

Schaltplan

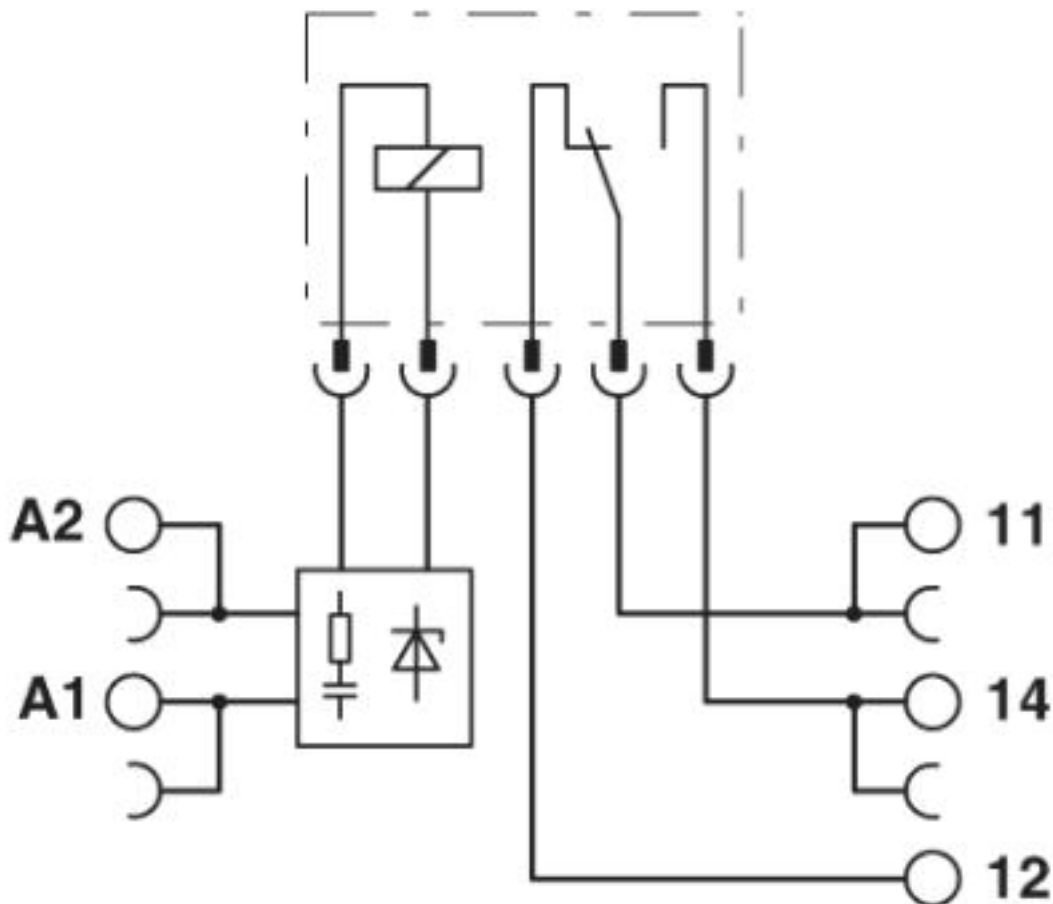

Relaissockel - PLC-BSC-120UC/21/SO46 - 2980319

Schaltplan

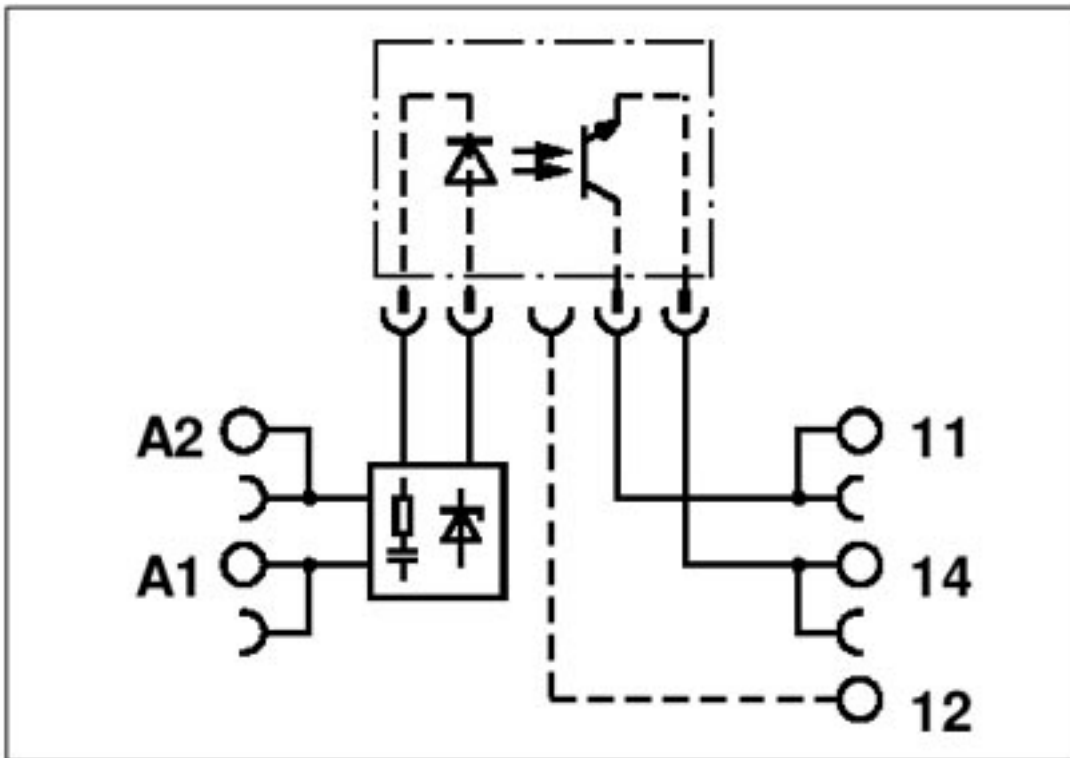

DC-Ausgang

Relaissockel - PLC-BSC-120UC/21/SO46 - 2980319

Schaltplan

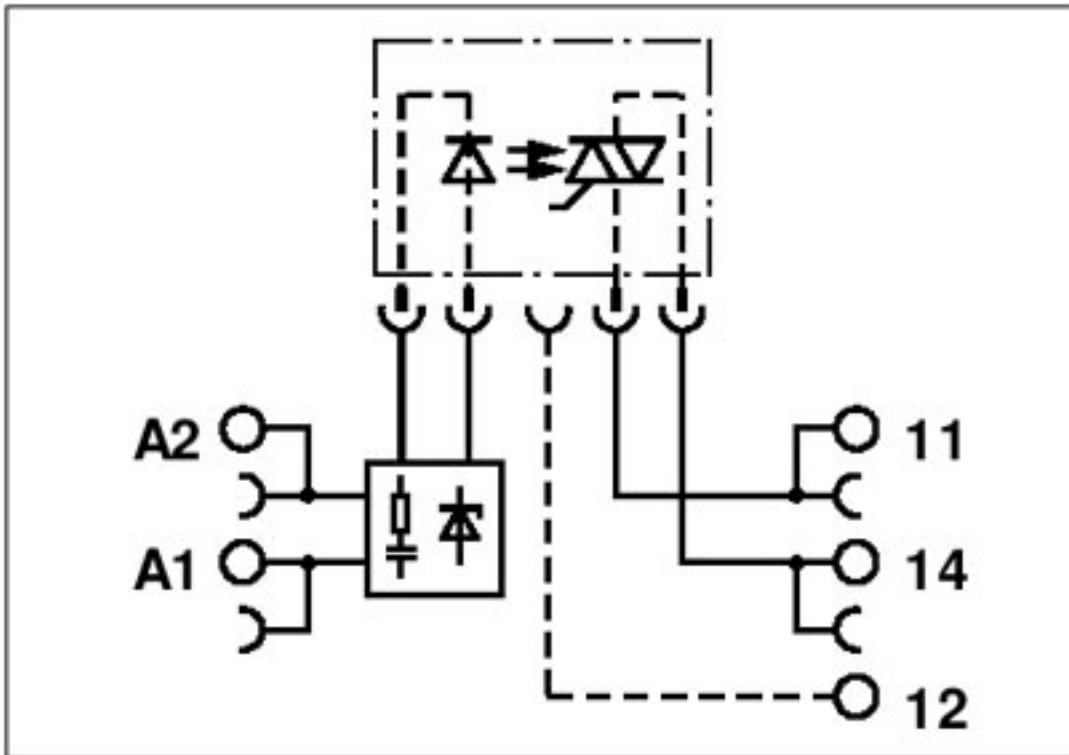

AC-Ausgang

© Phoenix Contact 2013 - alle Rechte vorbehalten
<http://www.phoenixcontact.com>