



Kabelverschraubung Kunststoff für Ex Bereich

SKINTOP® K-M ATEX plus

PDF DATASHEET

© 1992 - 2010 CADENAS GmbH

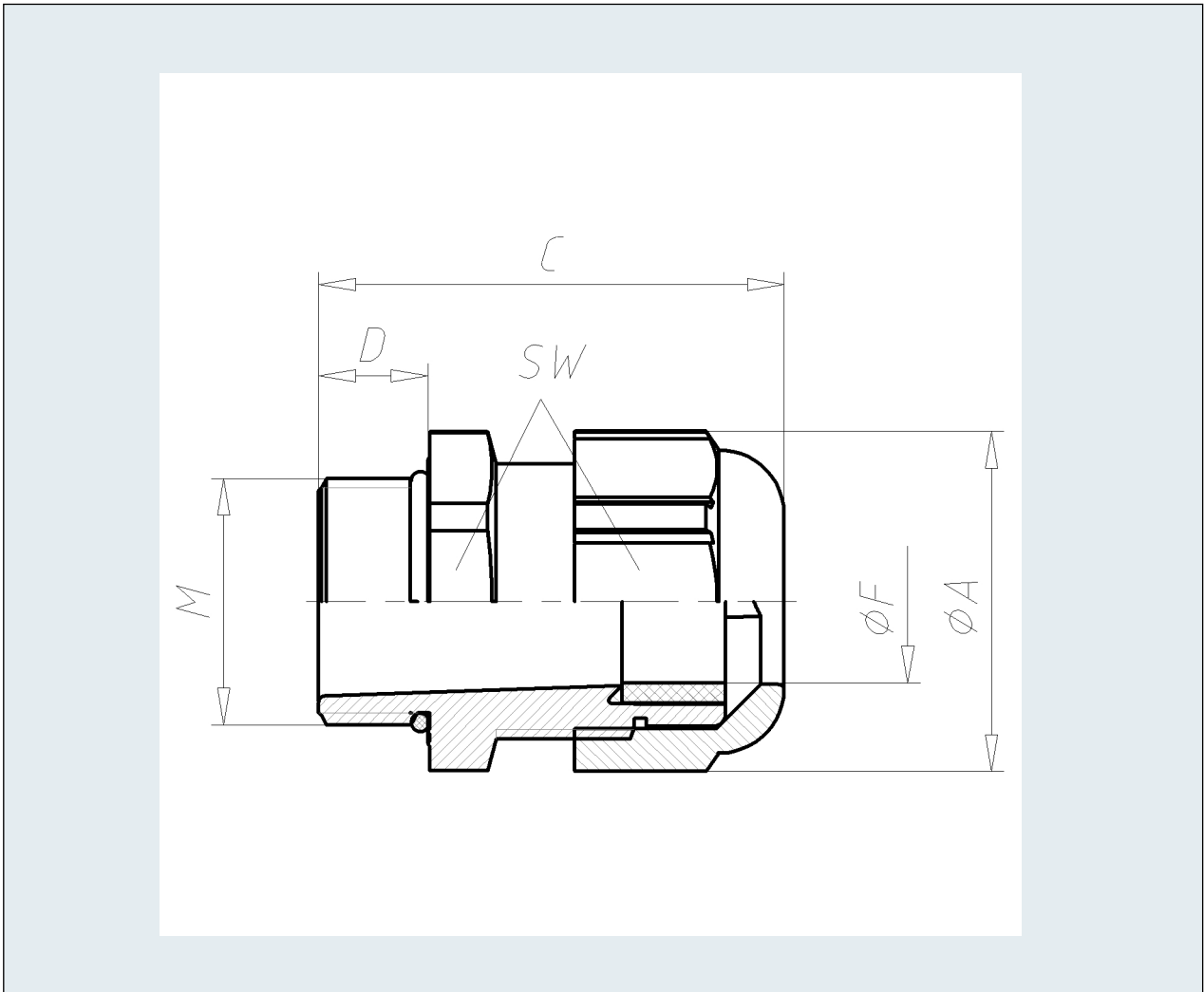
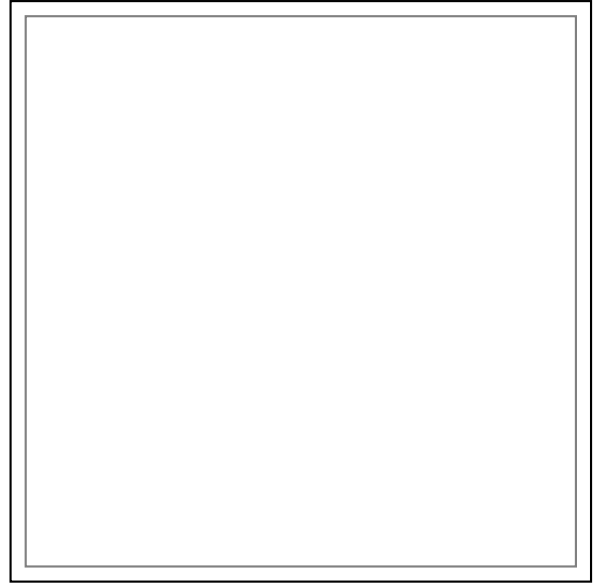
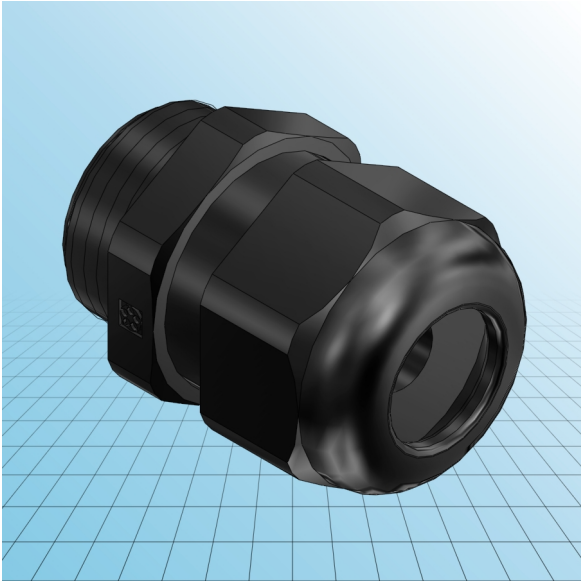



Kabelverschraubung Kunststoff für Ex Bereich

SKINTOP® K-M ATEX plus

IDNR (Identnummer)	
ATN (Artikel-Nummer)	54115220
M (Gewinde)	M 20x1,5
SW (Schlüsselweite / mm)	25
A (Eckmass / mm)	27.6
C (mm)	37
D (mm)	9
FMIN (Klemmbereich min. / mm)	7
FMAX (Klemmbereich max. / mm)	13
F (Kabeldurchmesser / mm)	7
MATERIAL (Material)	Kunststoff