

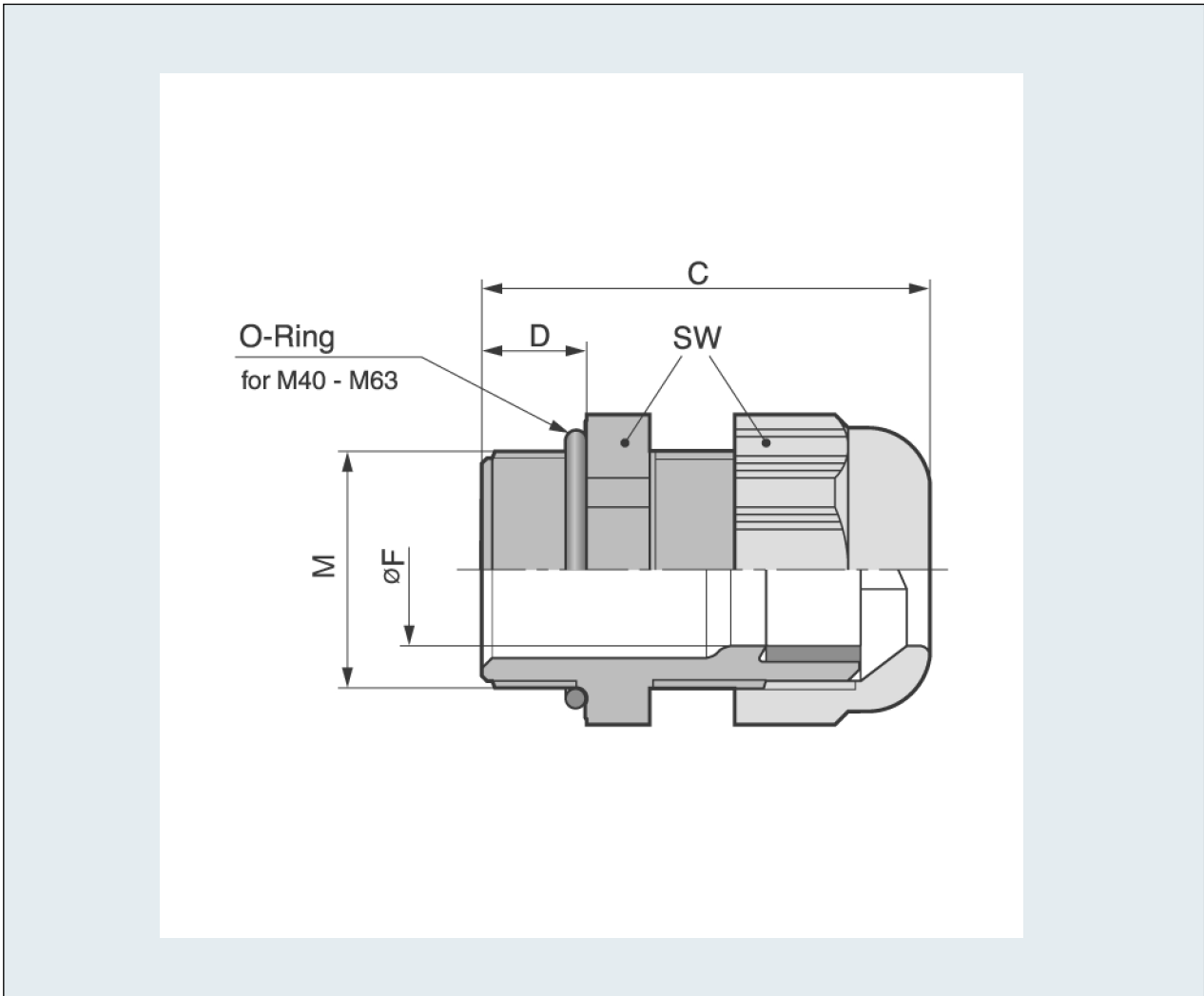

# Kabelverschraubung Kunststoff SKINTOP® ST-M

## PDF DATASHEET

© 1992 - 2010 CADENAS GmbH

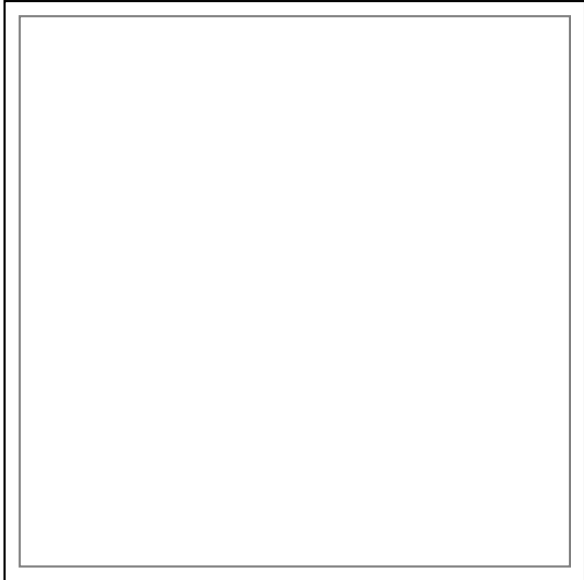
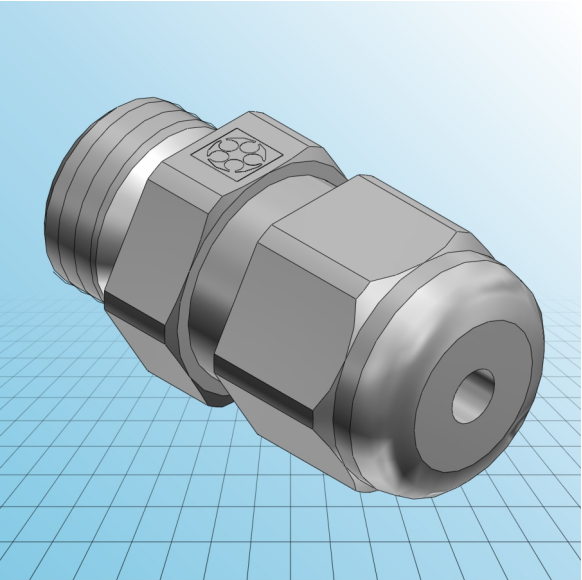



## Kabelverschraubung Kunststoff SKINTOP® ST-M

## PDF DATASHEET

© 1992 - 2010 CADENAS GmbH

<b>IDNR (Identnummer)</b>	
<b>ATN (Artikel-Nummer)</b>	53111200
<b>M (Gewinde)</b>	M 12x1,5
<b>FMIN (Klemmbereich min. / mm)</b>	3.5
<b>FMAX (Klemmbereich max. / mm)</b>	7
<b>F (Kabeldurchmesser / mm)</b>	3.5
<b>SW (Schlüsselweite / mm)</b>	15
<b>A (Eckmass / mm)</b>	16.6
<b>C (mm)</b>	30
<b>D (mm)</b>	8
<b>RAL7001 (Silbergrau)</b>	
<b>RAL7035 (Lichtgrau)</b>	
<b>RAL9005 (Tiefschwarz)</b>	X
<b>MATERIAL (Material)</b>	Kunststoff