

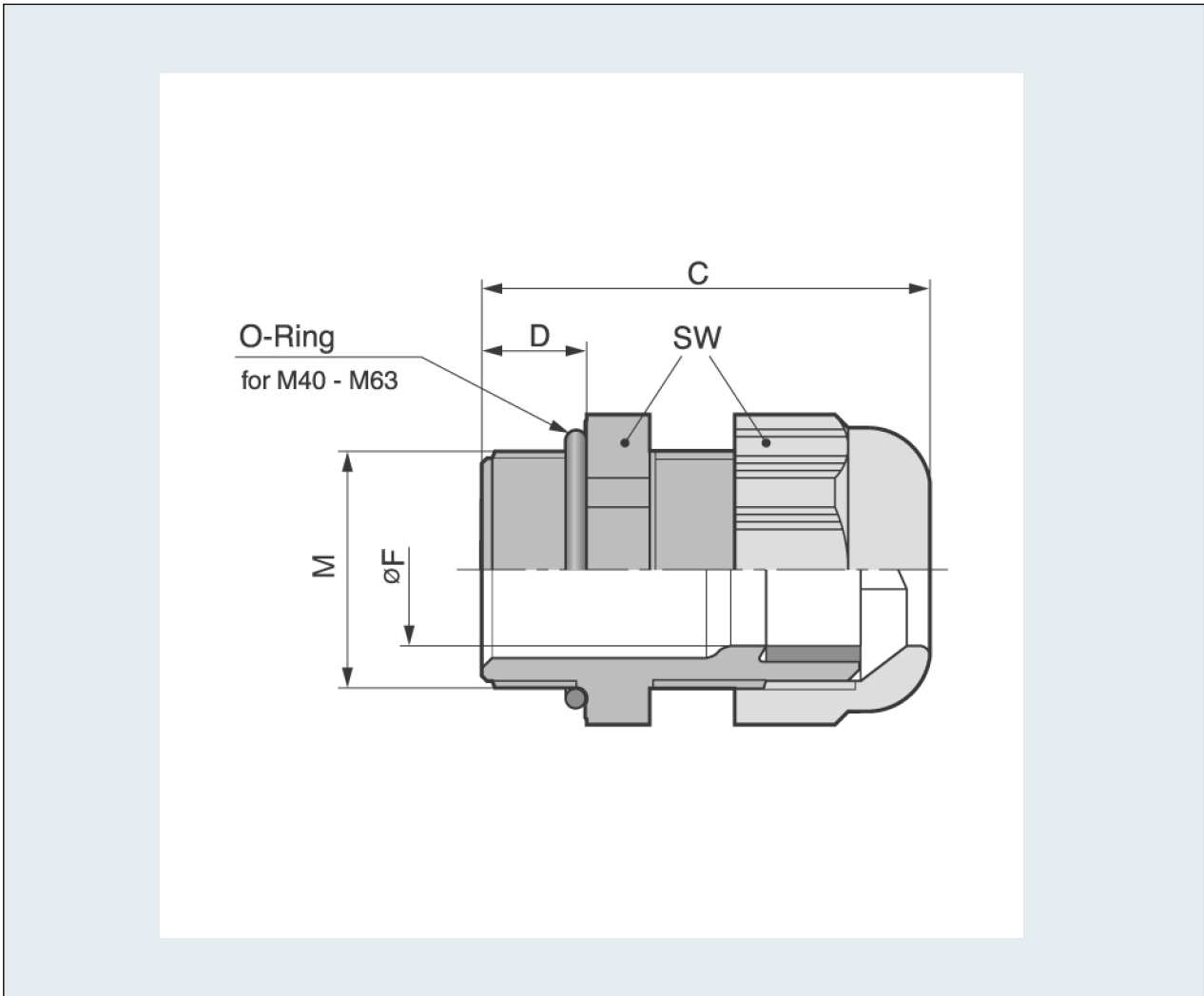

# Kabelverschraubung Kunststoff SKINTOP® ST-M

## PDF DATASHEET

© 1992 - 2010 CADENAS GmbH

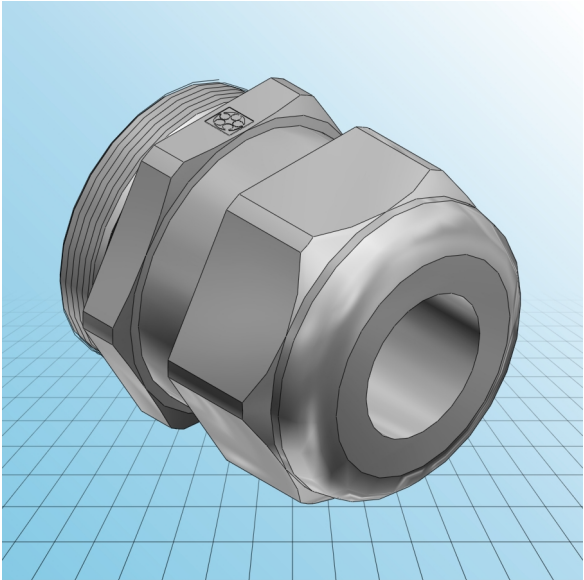



# Kabelverschraubung Kunststoff SKINTOP® ST-M

## PDF DATASHEET

© 1992 - 2010 CADENAS GmbH

IDNR (Identnummer)	
ATN (Artikel-Nummer)	53111260
M (Gewinde)	M 50x1,5
FMIN (Klemmbereich min. / mm)	27
FMAX (Klemmbereich max. / mm)	35
F (Kabeldurchmesser / mm)	27
SW (Schlüsselweite / mm)	55
A (Eckmass / mm)	61.6
C (mm)	62
D (mm)	12
RAL7001 (Silbergrau)	
RAL7035 (Lichtgrau)	
RAL9005 (Tiefschwarz)	X
MATERIAL (Material)	Kunststoff