

**UL US LISTED**  
 File #E65324  
 NEMA 4, 4X

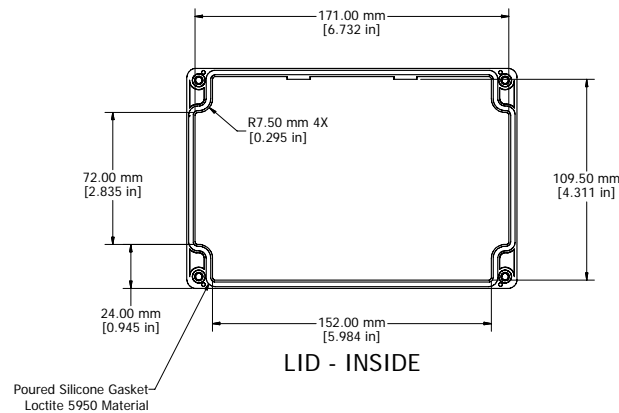
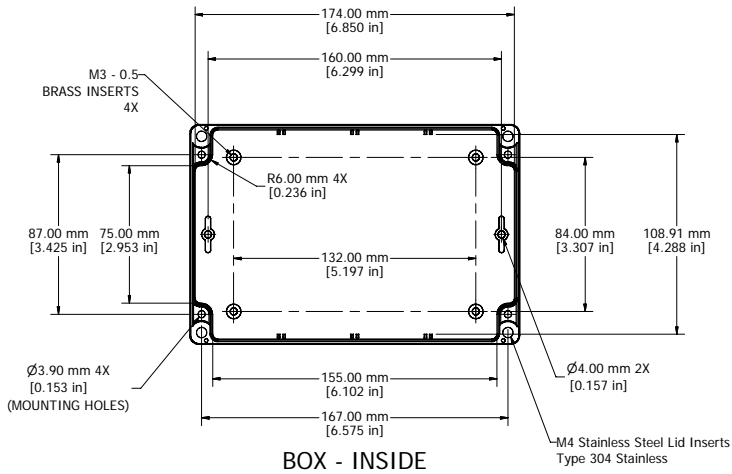
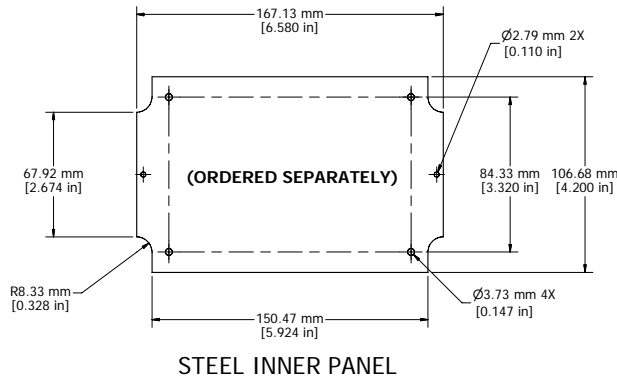
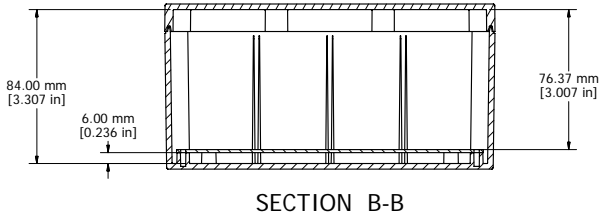
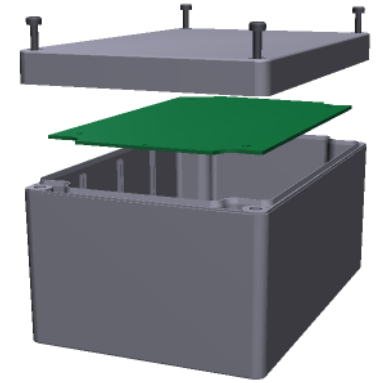

Enclosures can be Factory Modified ( Milling, Drilling, Printing etc. )  
 Contact [mjm@hammondmg.com](mailto:mjm@hammondmg.com) for Quotes.  
 Solid models of this enclosure available in STEP or IGES see Web.

NOTE	
Purchased assembly includes box, lid, and 4 cover screws	
Recommended Cover screw torque -- 2.5 lbf-in (30 cN-m)	
Polycarbonate version is UL 508 approved Mat'l UL94 - V0 / 5VA @ 3mm	

1554T	
<b>1554T Regular Enclosure</b>	
General Purpose ABS RAL-7035	1554TGY
Polycarbonate RAL-7035	1554T2GY
<b>1554T Clear / Smoke Lid Enclosure</b>	
Polycarbonate Box / Clear Polycarbonate Lid	1554T2GYCL
Polycarbonate Box / Smoke Polycarbonate Lid	1554T2GYCL
<b>ACCESSORIES</b>	
Heavy Duty 16 Gauge Galvanized Steel Panels	1554HPL
Steel Panel / P.C. Board Machine Screw [M3 x 8mm Nickel Plated]	1591MM100
Steel Panel / P.C. Board Self Tapping Screw [#6 X 1/4" (6.4mm) Nickel Plated]	1598ATS100
Cover Screws (Pkg 4) [M4 X 20mm Type 304 Stainless Steel]	SC1554

**HAMMOND MANUFACTURING™**  
**1554T**  
[www.hammondmg.com](http://www.hammondmg.com)