

LWL-Kupplung - PSM-SET-FSMA-LINK/2 - 2799416

Bitte beachten Sie, dass die hier angegebenen Daten dem Online-Katalog entnommen sind. Die vollständigen Informationen und Daten entnehmen Sie bitte der Anwenderdokumentation. Es gelten die Allgemeinen Nutzungsbedingungen für Internet-Downloads. (<http://download.phoenixcontact.de>)



Kupplung, Set bestehend aus 2 Kupplungen zur Verbindung von F-SMA-Steckern

Kaufmännische Daten

Verpackungseinheit	1
GTIN	4017918118396

Klassifikationen

eCl@ss

eCl@ss 4.0	27061001
eCl@ss 4.1	27061001
eCl@ss 5.0	27061803
eCl@ss 5.1	27061803
eCl@ss 6.0	27061803
eCl@ss 7.0	27061803
eCl@ss 8.0	27061803

ETIM

ETIM 2.0	EC000752
ETIM 3.0	EC000752
ETIM 4.0	EC000752
ETIM 5.0	EC000752

UNSPSC

UNSPSC 6.01	26121607
UNSPSC 7.0901	26121607
UNSPSC 11	26121607
UNSPSC 12.01	26121607
UNSPSC 13.2	26121607

Zubehör

Adapter

LWL-Kupplung - PSM-SET-FSMA-LINK/2 - 2799416

Zubehör

PSM-SET-BFOC-LINK/2 - 2799429



FL MM PATCH COUPLER LC-LC - 2700312



FL SM PATCH COUPLER LC-LC - 2700313



FL COUPLER SC-DUPLEX - 2901788



LWL-Steckverbinder (geräteseitig)

VS-SCRJ-GOF-BU/BU - 1652978



Stecker-Set

LWL-Kupplung - PSM-SET-FSMA-LINK/2 - 2799416

Zubehör

PSM-SET-FSMA/4-HCS - 2799487



PSM-SET-FSMA/4-KT - 2799720



Zeichnungen

Bohrplan

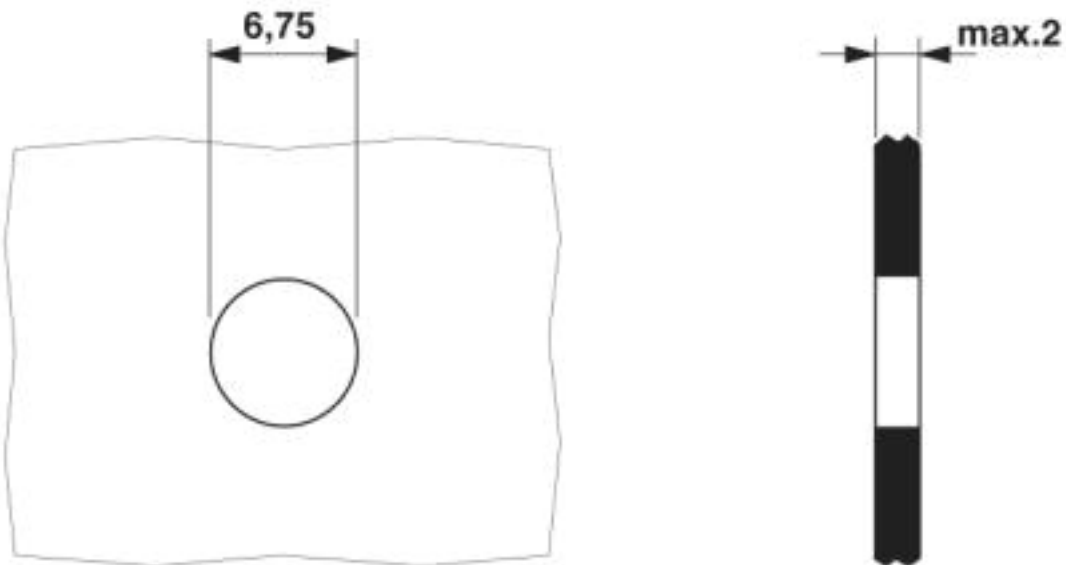

Bohrplan F-SMA-Wanddurchführung

LWL-Kupplung - PSM-SET-FSMA-LINK/2 - 2799416

Maßzeichnung

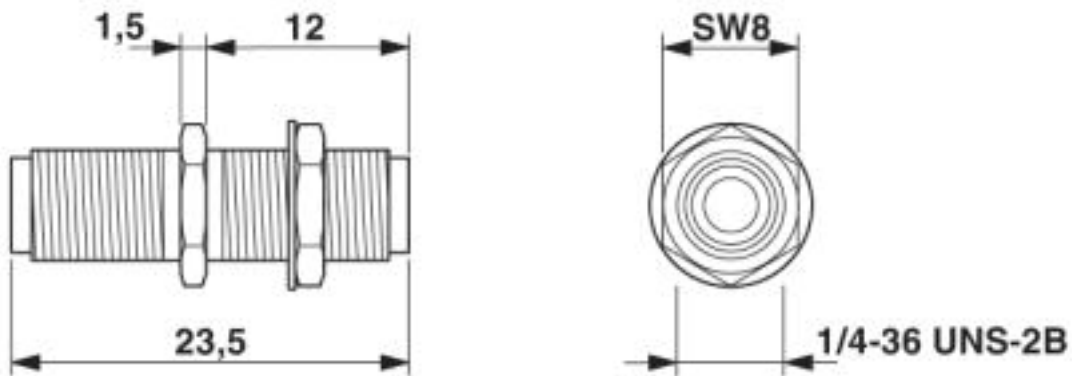

Maßbild F-SMA-Kupplung

© Phoenix Contact 2013 - alle Rechte vorbehalten
<http://www.phoenixcontact.com>