

# DC BRUSHLESS FAN QC9225B12H



## CC9225 SERIES

### FEATURES

SIZE:	92×92×25 mm
BEARING TYPE:	BALL , SLEEVE & ONE BALL & ONE SLEEVE BEARING
IMPELLER:	PLASTIC WITH FIBER GLASS FILLED UL 94V-0
FRAME:	PLASTIC WITH FIBER GLASS FILLED UL 94V-0
WEIGHT:	85(g)

---

## PERFORMANCE & DIMENSIONS

---

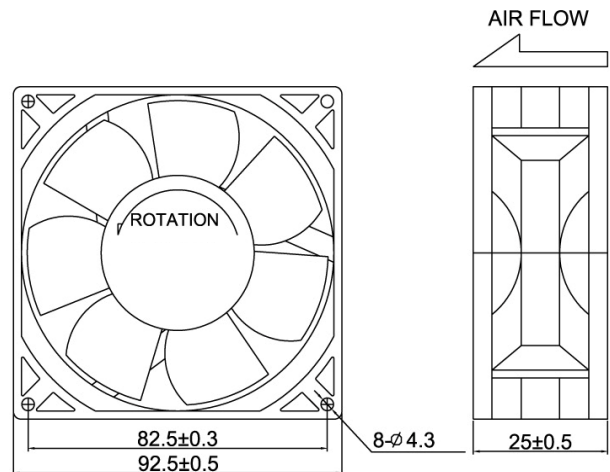
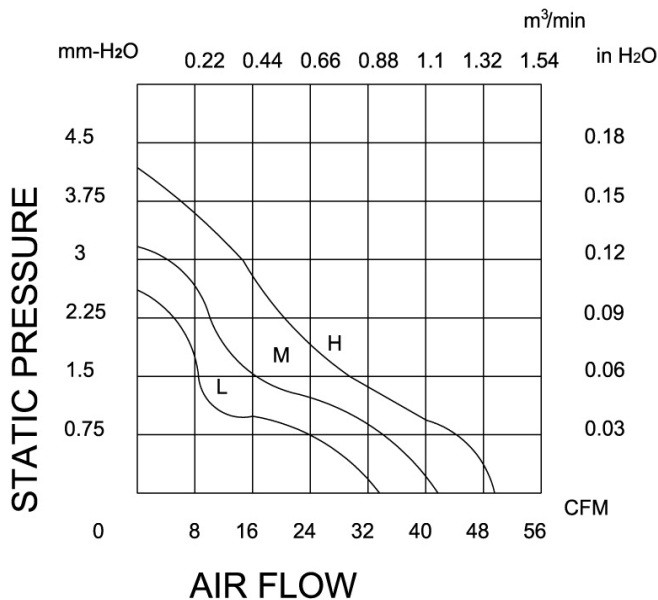

**Nennspannung: 12 VDC**

**Stromaufnahme: 0.32 A**

**Leistungsaufnahme: 3.84 W**

**Umdrehungen: 3000 /min**

**Volumenstrom: 100.24 m<sup>3</sup>/h**

**Geräuschpegel: 36 dBA**

**Lagerungsart: 2 Kugellager**

**Typische Lebensdauer: 60000 h (25°C)**

**Material: Glasfaserverstärktes Plastik UL 94V-0**

**Prüfzeichen: UL, CUL, TÜV, CE**

**Gewicht: 85 g**