

WITTENBERG

www.wittenberg-antennen.de

Wandhalterung verzinkt Winkelform

Artikelnummer K-103052



4 021064 103052 5

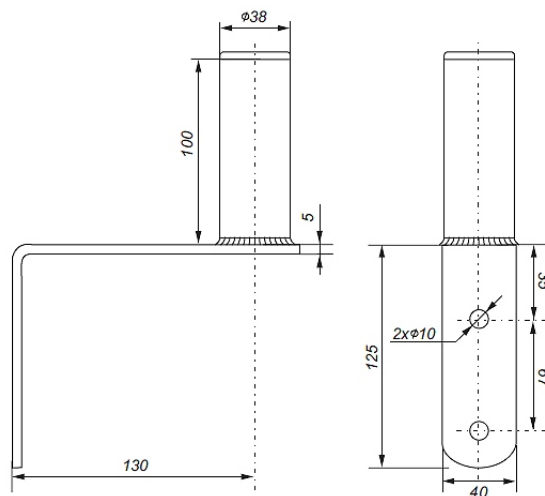

Wittenberg Antennen und Zubehör UG, GF Angela Wittenberg Vogesberg 8, 31167 Bockenem
Steuernummer 30-215-20776.

Kontonummer :IBAN:DE97259501300034747449 BIC:NOLADE21HIK Sparkasse Hildesheim