



## CATania 30 UP – MONTAGEANLEITUNG

**Vielen Dank, dass Sie sich für dieses qualitativ hochwertige Produkt aus dem Hause Barthelme entschieden haben!** Das CATania 30 UP-Profil kann bündig und nahezu ohne sichtbaren Rand in massive Wände integriert werden.

### GELTUNGSBEREICH:

- 62394111 CATania 30 Unterputzprofil, Aluminium Pressblank, 1 m
- 62394112 CATania 30 Unterputzprofil, Aluminium Pressblank, 2,01 m
- 62394113 CATania 30 Unterputzprofil, Aluminium Pressblank, 3,02 m
- 62394115 CATania 30 Unterputzprofil, Aluminium Pressblank, 5,03 m
- 62394121 CATania 30 Unterputzprofil für Netzteil einbau, Aluminium Pressblank, 1 m
- 62394122 CATania 30 Unterputzprofil für Netzteil einbau, Aluminium Pressblank, 2,01 m
- 62394131 CATania 30 Einleger für Unterputzprofil, Aluminium Pressblank, inkl. Bohrschrauben, 1 m
- 62394132 CATania 30 Einleger für Unterputzprofil, Aluminium Pressblank, inkl. Bohrschrauben, 2,01 m
- 62394133 CATania 30 Einleger für Unterputzprofil, Aluminium Pressblank, inkl. Bohrschrauben, 3,02 m
- 62394141 Endkappenset CATania 30 Unterputzprofil, Aluminium Pressblank, 2 Stück, inkl. 12 Schrauben

### IN VERBINDUNG MIT

- 6239982# CATania Abdeckung opalweiß, PMMA
- 6239985# CATania Abdeckung satiniert, PMMA
- 6239986# CATania Abdeckung klar, PMMA
- 6239987# CATania Abdeckung Prisma klar, PMMA
- 6239885# Abdeckung, Aluminium, eloxiert, z.B. zum Verbergen von Steuerungstechnik, 1 m

.....

## MONTAGE UND ANSCHLUSS



Wenn Sie eine Wand mechanisch bearbeiten, so achten Sie unbedingt darauf, dass Sie keine Kabel oder Leitungen beschädigen! Zudem ist die Statik zu berücksichtigen!



Schutzhandschuhe verwenden bei der Montage!  
Den Aufbau zu zweit ausführen!

Sie brauchen zusätzlich:

- » Mauernutfräse
- » Dosenbohrer
- » Hammer
- » Meißel

## MONTAGANLEITUNG FÜR CATANIA UP

### 1. GEPLANTE LICHTLINIE MARKIEREN.

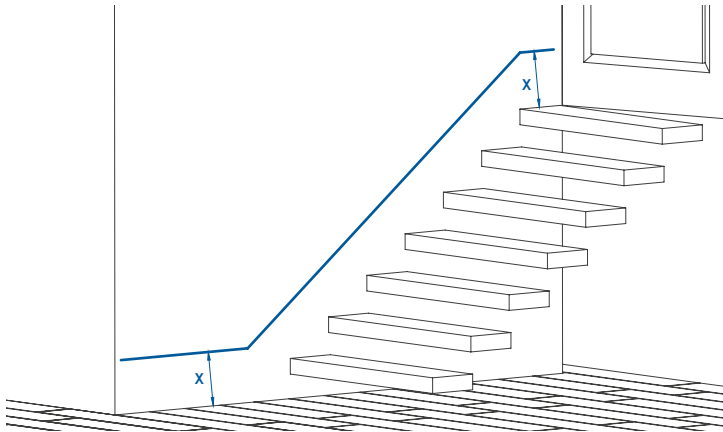

### 2. AUSSCHNITT IN ROHBAUWAND HERSTELLEN.

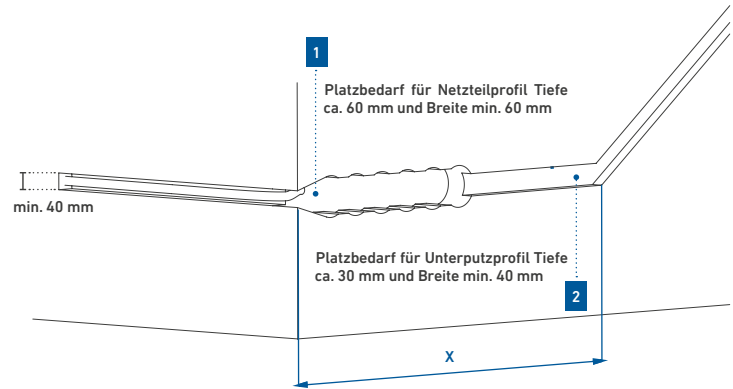

1  
Netzteilprofil ca. 54 mm

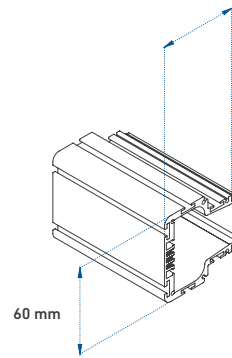

2  
Unterputzprofil ca. 24 mm

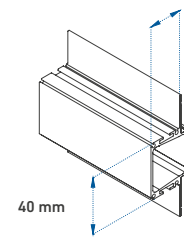

3. UNTERPUTZ- UND NETZTEILPROFIL AUF DIE GEWÜNSCHTE LÄNGE ZUSÄGEN UND MITTELS VERBINDER ZUSAMMENFÜGEN.

PROFILKOMBINATION SOLLTE MIN. 10 MM KÜRZER SEIN, ALS DER WANDAUSCHNITT.

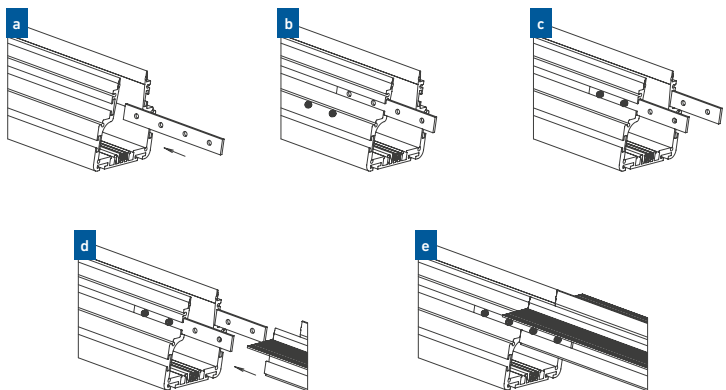
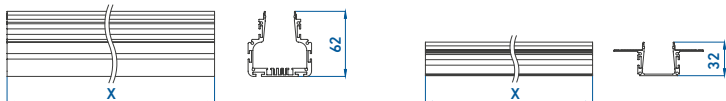

MÖGLICHE VERBINDER

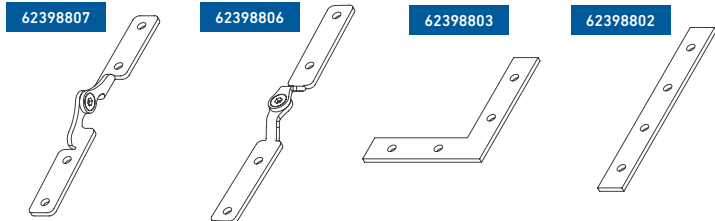

4. ENDKAPPEN ANBRINGEN.

A Netzteilprofil halbseitig (bei Bedarf vorgelasserte Durchführung für Kabeleinführung ausbrechen)

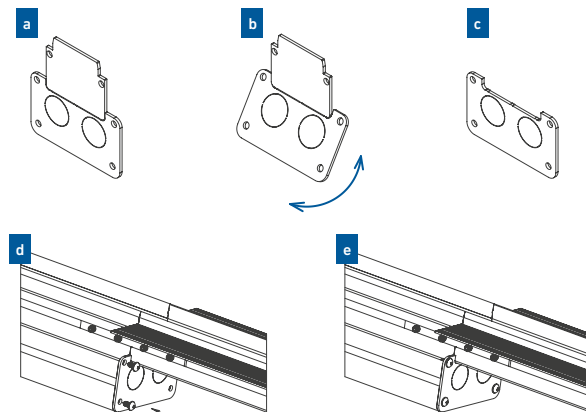

B Netzteilprofil komplett (bei Bedarf vorgelasserte Durchführung für Kabeleinführung ausbrechen)

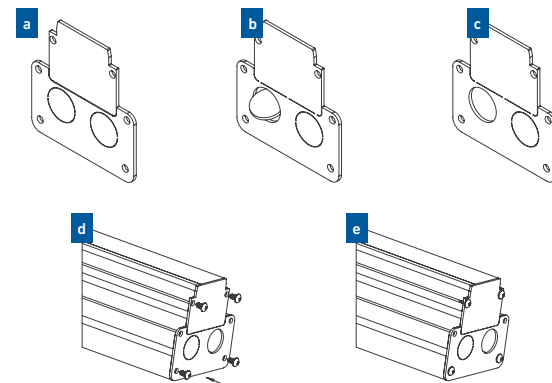

C Unterputzprofil

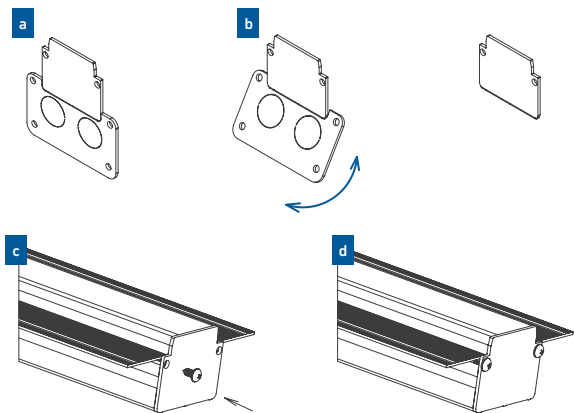

5. PRÜFEN OB DAS PROFIL LEICHGÄNGIG IN DAS MAUERWERK PASST.

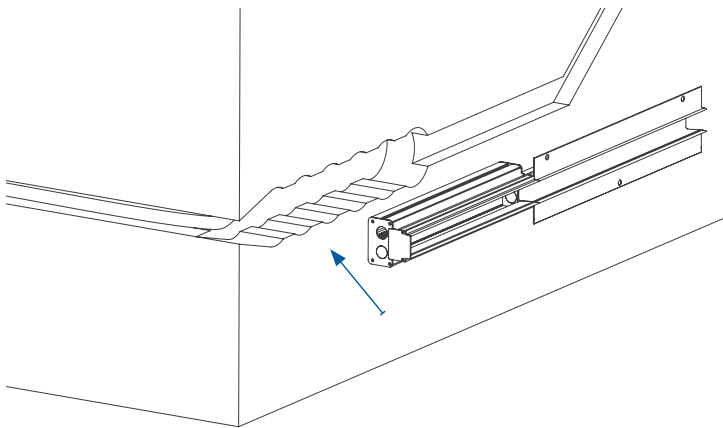

6. KABEL/LEERROHR IN DAS PROFIL FÜHREN.

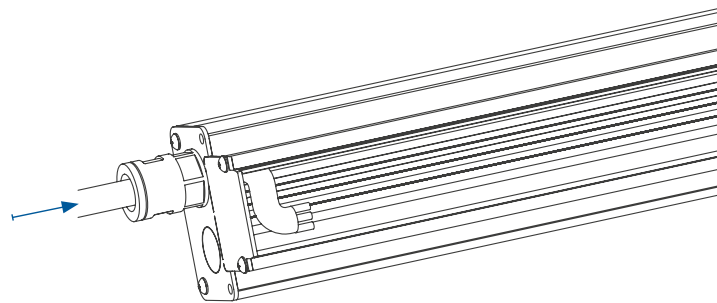

7. PUNKTUELL INSTALLATIONSGIPS IN MAUERWERK GEBEN.

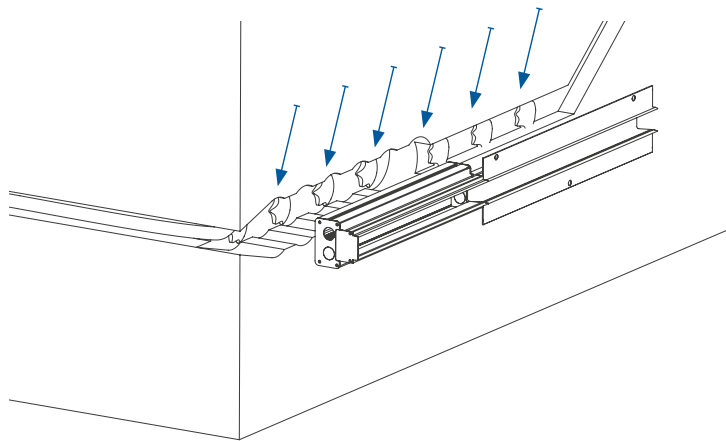

**8. PROFIL EINDRÜCKEN BIS DIE FLÜGEL AM MAUERWERK ANLIEGEN (PUTZSTÄRKE = 9 MM).**

Bei gewünschter Putzstärke von > 9 mm entsprechend Abstand zwischen Flügel und Mauerwerk einhalten.

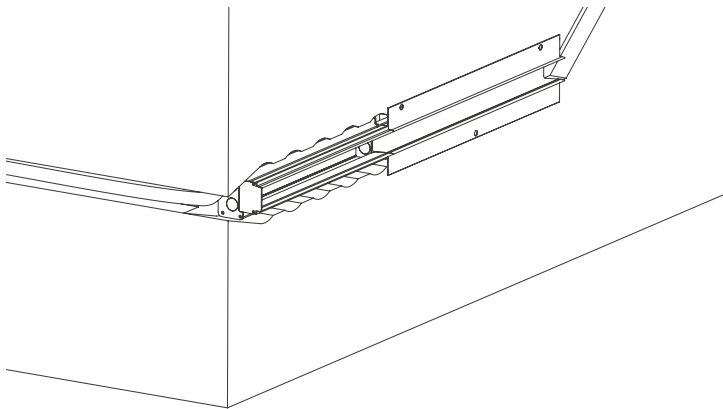

**10. SCHAUMSTOFFEINSATZ BÜNDIG IN DAS PROFIL EINDRÜCKEN.**

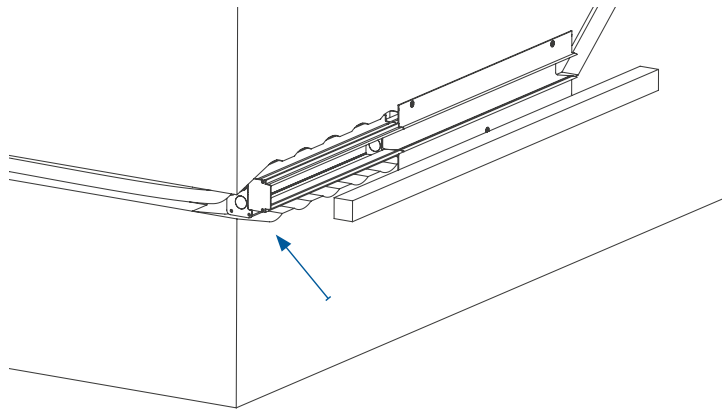

**9. PROFIL AUSRICHTEN, GIPS AUSHÄRTEN LASSEN UND GGF. MIT SCHRAUBEN FIXIEREN ODER ZUSÄTZLICHEN GIPS AN GEEIGNETEN STELLEN ANBRINGEN.**

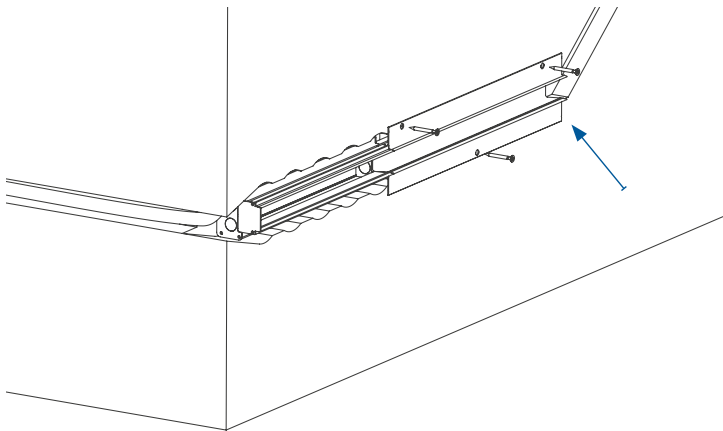

**11. WAND VERPUTZEN (BÜNDIG!) WIR EMPFEHLEN DIE VERWENDUNG VON GIPSPUTZ.**

NACH DEN VERPUTZARBEITEN SCHAUMSTOFF ENTFERNEN.

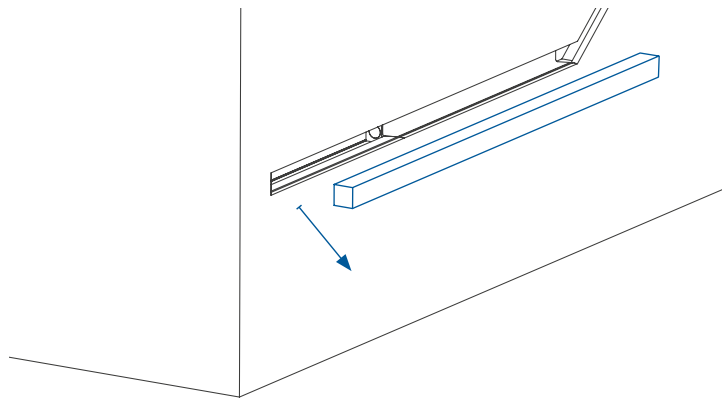

## 12. NETZTEIL MIT ANSCHLUSSLEITUNG ANSCHLIESSEN



**ACHTUNG!**  
Diese Tätigkeit darf nur von einer ausgebildeten Elektrofachkraft durchgeführt werden!  
Anschlusshinweise des Netzteils beachten!



## 13. NETZTEIL IM NETZTEILPROFIL VERSCHRAUBEN.

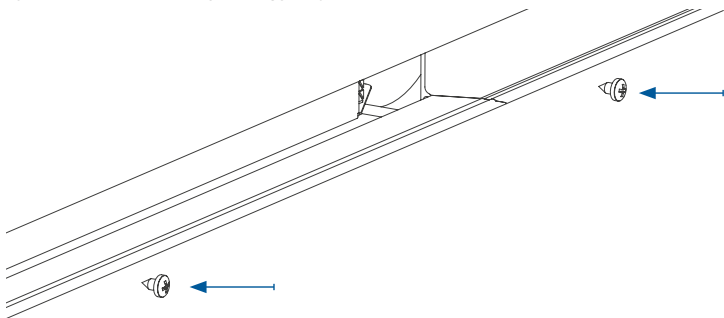

## 14. EINLEGERPROFIL AUF DIE GEWÜNSCHTE LÄNGE ZUSÄGEN (EINLEGER ÜBERDECKT NETZTEIL). BOHRUNG FÜR SPANNUNGSVERSORGUNG DES LED-STREIFENS HERSTELLEN.

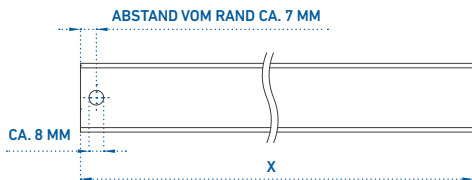

## 15. KABEL AM LED-STREIFEN ANLÖTEN UND DURCH DAS PROFIL FÜHREN.

a

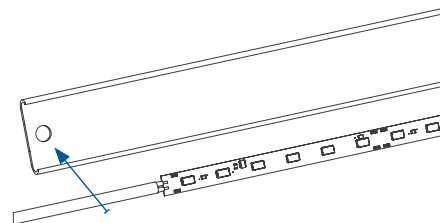

b

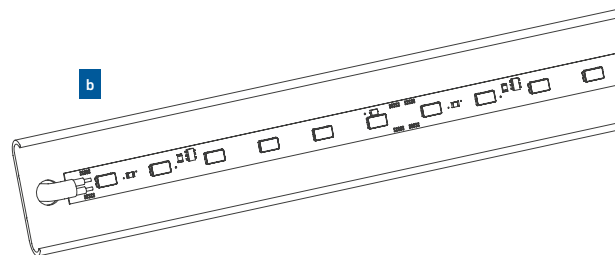

## 16. EINLEGERPROFIL IM UNTERPUTZPROFIL POSITIONIEREN UND MITTELS BEIGELEGTER BOHR- SCHRAUBEN BEFESTIGEN.



**ACHTUNG!**  
Die Verschraubung erfolgt nicht auf Höhe des Netzteilprofils!

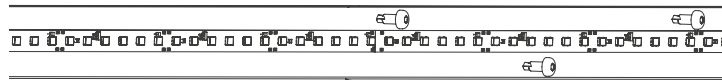

17. ABDECKUNG AUF DIE GEWÜNSCHTE LÄNGE SÄGEN.

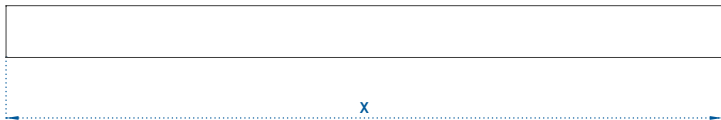

18. ABDECKUNG EINCLIPSEN.

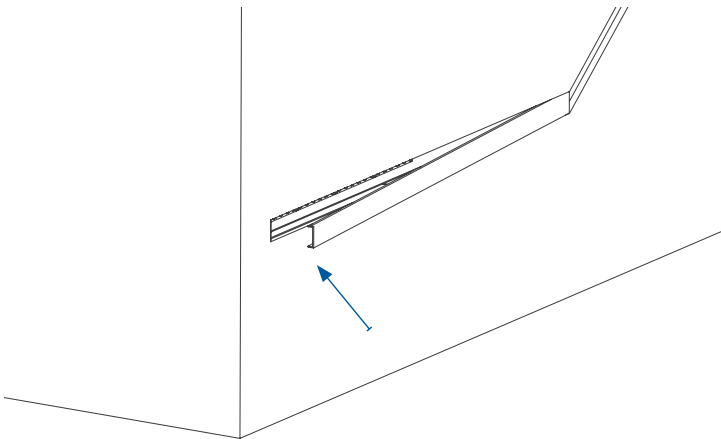

Änderungen vorbehalten



**Barthelme**  
LED Solutions

STAND 06|2021

© JOSEF BARTHELME GMBH & CO. KG  
Oedenberger Straße 149 | 90491 Nürnberg | Deutschland  
T +49 911 42476 0 F +49 911 42476 66 E info@barthelme.de

**BARTHELME.DE**







## CATania 30 UP – INSTALLATION INSTRUCTIONS

**Thank you for choosing this high-quality product from Barthelme!** The CATania 30 UP profile can be integrated flush and with virtually no visible edge in solid walls.

### SCOPE OF APPLICATION:

- 62394111 CATania 30 in-wall profile, aluminium, press finish, 1 m
- 62394112 CATania 30 in-wall profile, aluminium, press finish, 2.01 m
- 62394113 CATania 30 in-wall profile, aluminium, press finish, 3.02 m
- 62394115 CATania 30 in-wall profile, aluminium, press finish, 5.03 m
- 62394121 CATania 30 in-wall profile for power supply unit installation, aluminium, press finish, 1 m
- 62394122 CATania 30 in-wall profile for power supply unit installation, aluminium, press finish, 2.01 m
- 62394131 CATania 30 insert for in-wall profile, aluminium, press finish, incl. drilling screws, 1 m
- 62394132 CATania 30 insert for in-wall profile, aluminium, press finish, incl. drilling screws, 2.01 m
- 62394133 CATania 30 insert for in-wall profile, aluminium, press finish, incl. drilling screws, 3.02 m
- 62394141 end cap set CATania 30 in-wall profile, aluminium, press finish, 2 pieces, incl. 12 screws

### IN COMBINATION WITH

- 6239982# CATania 3030 Leuchtenprofil diffuser, opal white,, PMMA
  - 6239985# CATania diffuser, satined, PMMA
  - 6239986# CATania diffuser, clear, PMMA
  - 6239987# CATania Adiffuser, prisma clear, PMMA
  - 6239885# cover, aluminium, anodised, e.g. for concealing control technology, 1 m
-

## INSTALLATION AND CONNECTION



If you work mechanically on a wall, make absolutely sure that you do not damage any cables or wiring! In addition, the statics must be taken into account!



Use protective gloves during installation!  
Two people should carry out the task!

You will also need:

- » slot cutter
- » can drill
- » hammer
- » chisel

## INSTALLATION INSTRUCTIONS FOR CATANIA UP

### 1. MARK THE PLANNED LIGHT LINE.

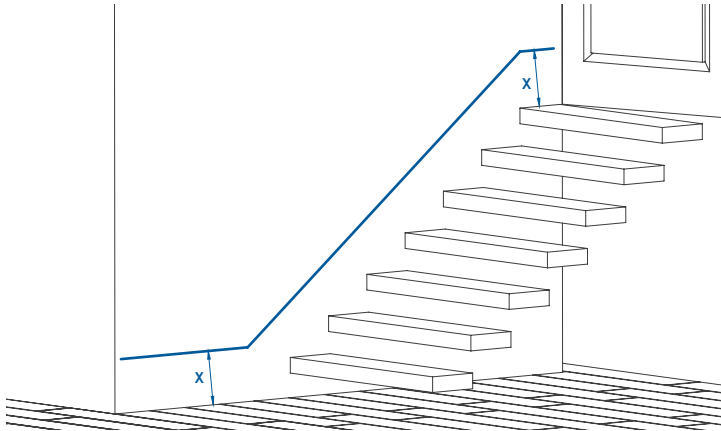

### 2. MAKE A CUT-OUT IN THE SHELL WALL.

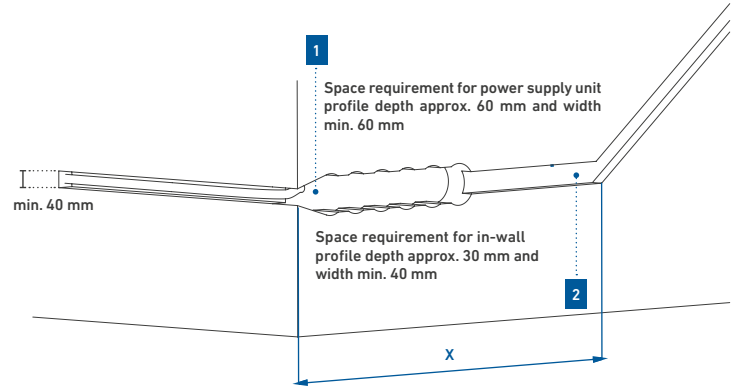

**1**  
Power supply profile approx. 54 mm

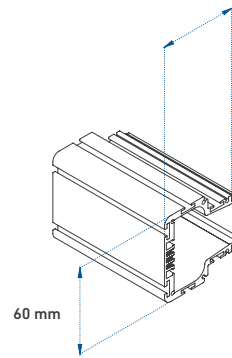

**2**  
In-wall profile approx. 24 mm

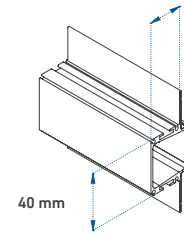

3. CUT THE IN-WALL AND POWER SUPPLY PROFILE TO THE REQUIRED LENGTH AND JOIN THEM TOGETHER USING A CONNECTOR.

THE PROFILE COMBINATION SHOULD BE AT LEAST 10 MM SHORTER THAN THE WALL CUT-OUT.

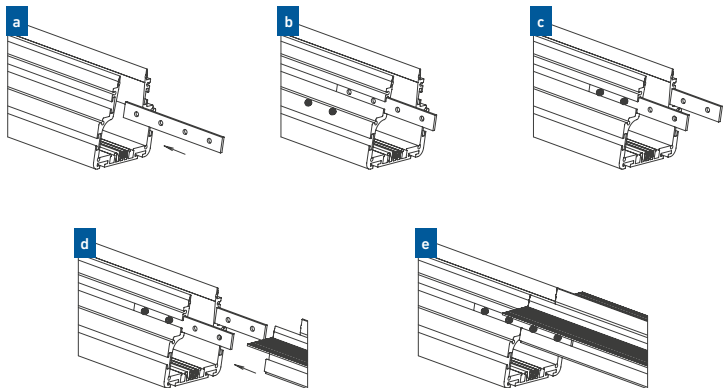
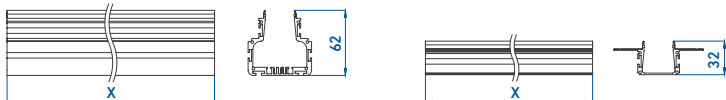

POSSIBLE CONNECTORS

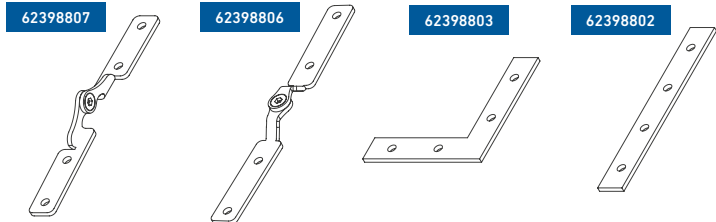

4. ATTACH END CAPS.

A Power supply unit profile half-sided (break out pre-lasered feed-through for cable entry if required)

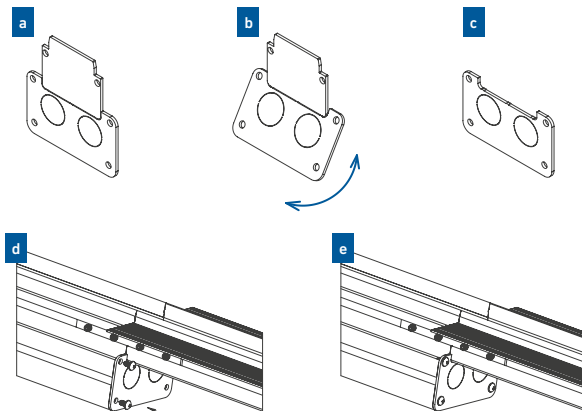

B Power supply unit profile complete (break out pre-lasered feed-through for cable entry if required)

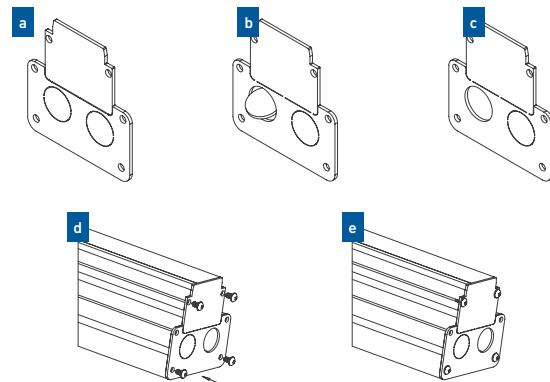

C In-wall profile

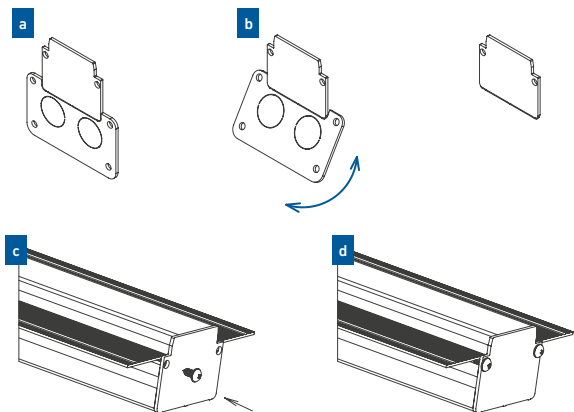

5. CHECK THAT THE PROFILE FITS EASILY INTO THE MASONRY.

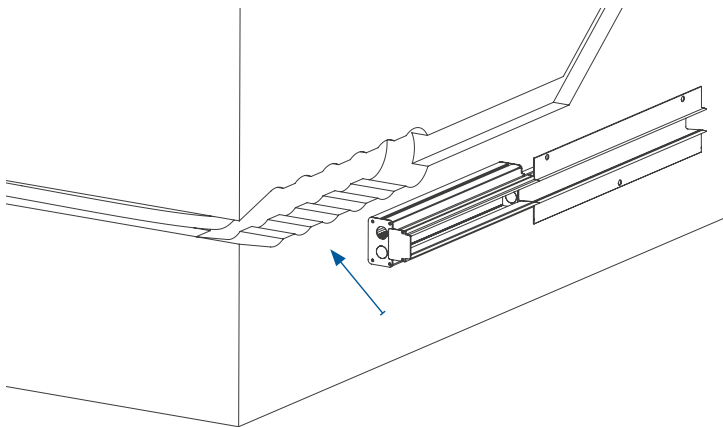

6. GUIDE THE CABLE/EMPTY CONDUIT INTO THE PROFILE.

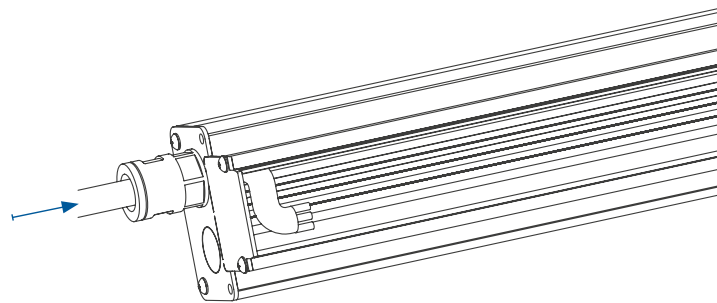

7. SELECTIVELY APPLY INSTALLATION PLASTER IN MASONRY.

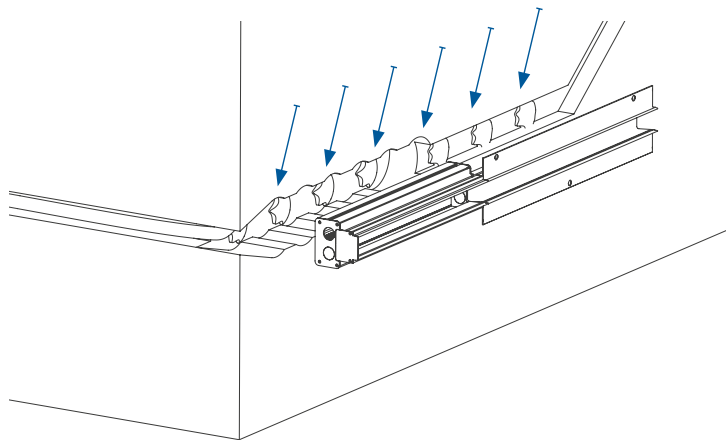

**8. PRESS IN THE PROFILE UNTIL THE WINGS ARE IN CONTACT WITH THE MASONRY  
(PLASTER THICKNESS = 9 MM).**

If a plaster thickness of > 9 mm is required, maintain a corresponding distance between the wings and the masonry.

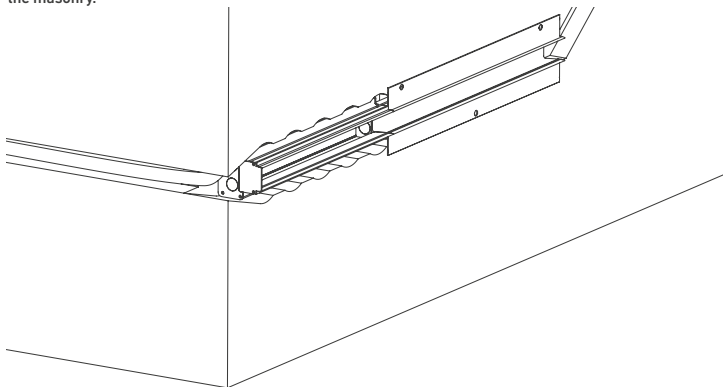

**9. ALIGN THE PROFILE, ALLOW THE PLASTER TO HARDEN AND, IF NECESSARY, FASTEN WITH SCREWS OR APPLY ADDITIONAL PLASTER IN SUITABLE PLACES.**

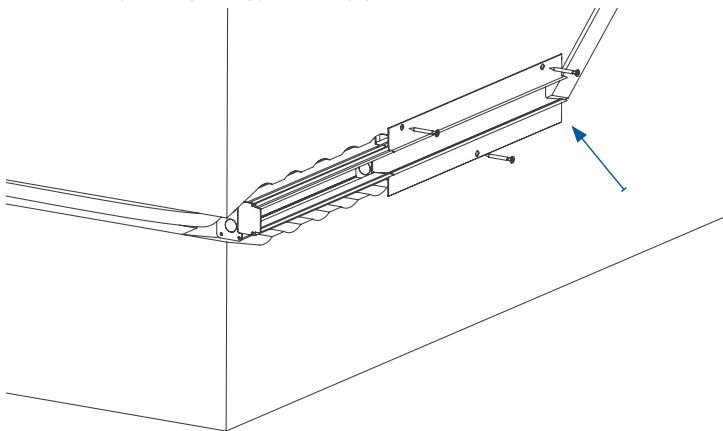

**10. FIT THE FOAM INSERT FLUSH INTO THE PROFILE.**

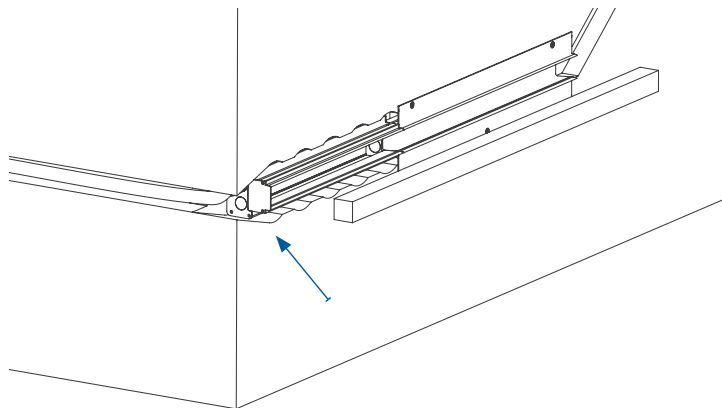

**11. PLASTER THE WALL (FLUSH!)  
WE RECOMMEND THE USE OF GYPSUM PLASTER.  
REMOVE FOAM INSERT AFTER PLASTERING WORK.**

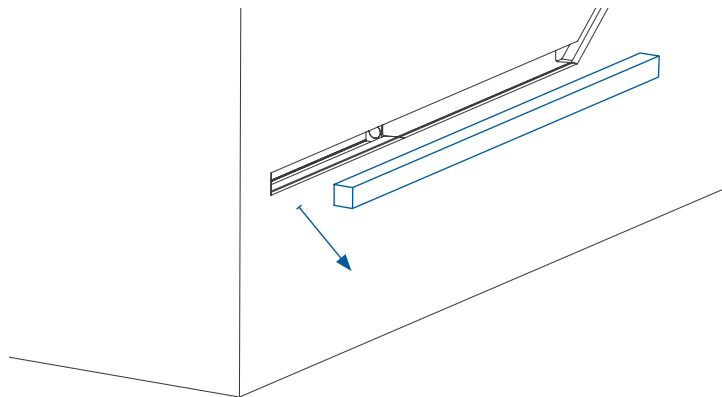

12. CONNECT THE POWER SUPPLY UNIT WITH THE CONNECTION CABLE



**ATTENTION!**  
THIS ACTIVITY MAY ONLY BE CARRIED OUT BY A TRAINED ELECTRICIAN! OBSERVE THE CONNECTION INSTRUCTIONS OF THE POWER SUPPLY UNIT!



13. SCREW THE POWER SUPPLY UNIT INTO THE POWER SUPPLY PROFILE.

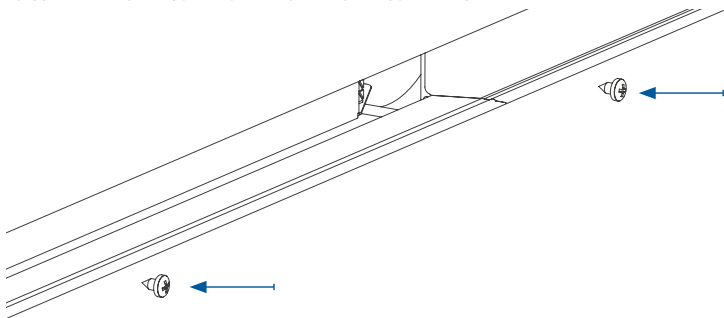

14. CUT THE INSERT PROFILE TO THE DESIRED LENGTH (INSERT COVERS THE POWER SUPPLY UNIT).  
DRILL A HOLE FOR THE POWER SUPPLY OF THE LED STRIP.

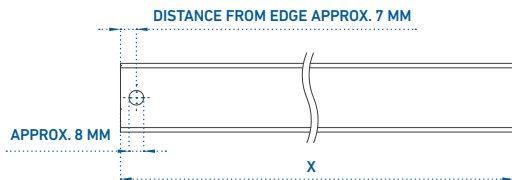

15. SOLDER THE CABLE TO THE LED STRIP AND ROUTE IT THROUGH THE PROFILE.

a

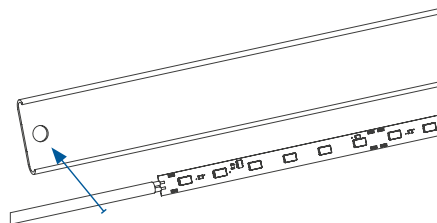

b

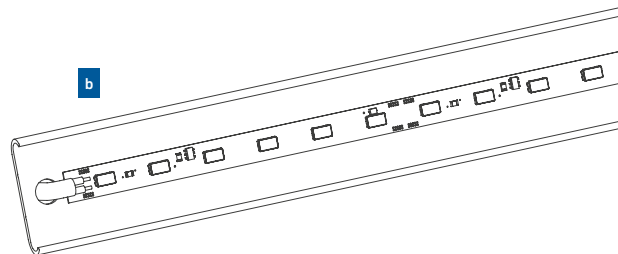

16. PLACE THE INSERT PROFILE IN THE IN-WALL PROFILE AND SECURE IT WITH THE ENCLOSED DRILLING SCREWS.



**ATTENTION!**  
The screw connection is not made at the height of the power supply unit profile!

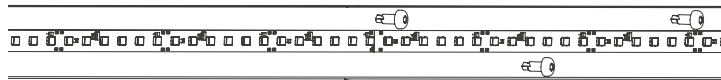

17. CUT THE DIFFUSER TO THE REQUIRED LENGTH.

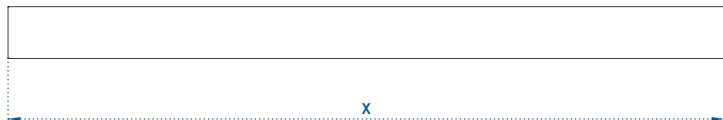

18. CLIP IN THE DIFFUSER.

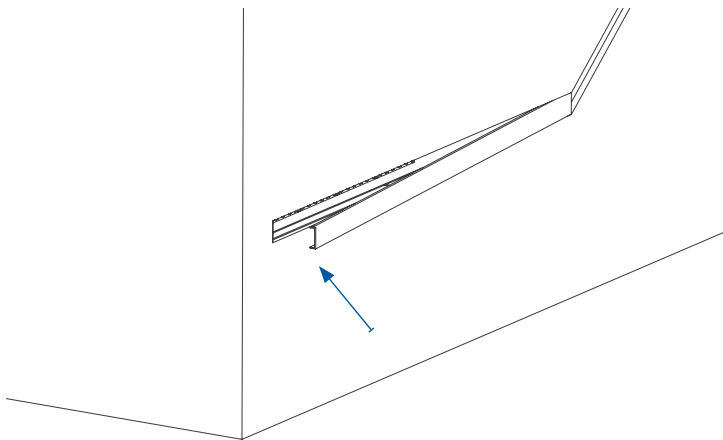

Subject to change.



**Barthelme**  
LED Solutions

VERSION 06|2021

© JOSEF BARTHELME GMBH & CO. KG  
Oedenberger Straße 149 | 90491 Nürnberg | Deutschland  
T +49 911 42476 0 F +49 911 42476 66 E info@barthelme.de

**BARTHELME.DE**