

# Magelis Advanced Panels

## HMI GXO

### User Manual

12/2016



EIO00000009963.03

---

The information provided in this documentation contains general descriptions and/or technical characteristics of the performance of the products contained herein. This documentation is not intended as a substitute for and is not to be used for determining suitability or reliability of these products for specific user applications. It is the duty of any such user or integrator to perform the appropriate and complete risk analysis, evaluation and testing of the products with respect to the relevant specific application or use thereof. Neither Schneider Electric nor any of its affiliates or subsidiaries shall be responsible or liable for misuse of the information contained herein. If you have any suggestions for improvements or amendments or have found errors in this publication, please notify us.

No part of this document may be reproduced in any form or by any means, electronic or mechanical, including photocopying, without express written permission of Schneider Electric.

All pertinent state, regional, and local safety regulations must be observed when installing and using this product. For reasons of safety and to help ensure compliance with documented system data, only the manufacturer should perform repairs to components.

When devices are used for applications with technical safety requirements, the relevant instructions must be followed.

Failure to use Schneider Electric software or approved software with our hardware products may result in injury, harm, or improper operating results.

Failure to observe this information can result in injury or equipment damage.

© 2016 Schneider Electric. All Rights Reserved.

---

# Table of Contents

---



	<b>Safety Information</b> .....	5
	<b>About the Book</b> .....	7
<b>Chapter 1</b>	<b>HMIGXO Panels</b> .....	9
	Package Contents .....	10
	Parts Identification and Functions .....	11
	Certifications and Standards .....	13
	HMIGXO Series of Panels .....	14
<b>Chapter 2</b>	<b>Device Connectivity</b> .....	17
	System Design .....	18
	Accessories .....	22
<b>Chapter 3</b>	<b>Specifications</b> .....	25
3.1	General Specifications .....	26
	Specifications .....	27
	Structural Specifications .....	30
3.2	Functional Specifications .....	31
	Display Specifications .....	32
	Memory, Clock, and Touch Panel .....	33
3.3	Interface Specifications .....	34
	Interface Specifications .....	35
	Serial Interface Specifications COM1 .....	37
	Serial Interface Specifications COM2 .....	39
3.4	Dimensions .....	41
	HMIGXO350• Dimensions .....	42
	HMIGXO5502 Dimensions .....	44
	Panel-cut Dimensions .....	46
	Installation Fasteners .....	47
<b>Chapter 4</b>	<b>Installation and Wiring</b> .....	49
4.1	Installation .....	50
	Installation Procedures .....	51
	Real Time Clock (RTC) .....	55
4.2	Wiring Principles .....	57
	Connecting the Power Cord .....	58
	Connecting the Power Supply .....	61
	Grounding .....	63

---

4.3	USB Port .....	65
	Important Considerations When Using the USB Port .....	66
	USB Data Transfer Cable (BMXXCAUSBH018) .....	67
	USB Holder Type A .....	69
	USB Type Mini B .....	71
<b>Chapter 5</b>	<b>Maintenance</b> .....	<b>73</b>
	Regular Cleaning .....	74
	Periodic Check Points .....	75
<b>Index</b>	.....	<b>77</b>

---

# Safety Information

---



## Important Information

### NOTICE

Read these instructions carefully, and look at the equipment to become familiar with the device before trying to install, operate, or maintain it. The following special messages may appear throughout this documentation or on the equipment to warn of potential hazards or to call attention to information that clarifies or simplifies a procedure.



The addition of this symbol to a “Danger” or “Warning” safety label indicates that an electrical hazard exists which will result in personal injury if the instructions are not followed.



This is the safety alert symbol. It is used to alert you to potential personal injury hazards. Obey all safety messages that follow this symbol to avoid possible injury or death.

## **DANGER**

**DANGER** indicates a hazardous situation which, if not avoided, **will result in** death or serious injury.

## **WARNING**

**WARNING** indicates a hazardous situation which, if not avoided, **could result in** death or serious injury.

## **CAUTION**

**CAUTION** indicates a hazardous situation which, if not avoided, **could result** in minor or moderate injury.

## **NOTICE**

**NOTICE** is used to address practices not related to physical injury.

---

## PLEASE NOTE

Electrical equipment should be installed, operated, serviced, and maintained only by qualified personnel. No responsibility is assumed by Schneider Electric for any consequences arising out of the use of this material.

A qualified person is one who has skills and knowledge related to the construction and operation of electrical equipment and its installation, and has received safety training to recognize and avoid the hazards involved.

---

# About the Book

---



## At a Glance

### Document Scope

This manual describes how to use the HMIGXO panels.

### Validity Note

This documentation is valid for Vijeo Designer 6.2 or higher.

The technical characteristics of the devices described in this document also appear online. To access this information online:

Step	Action
1	Go to the Schneider Electric home page <a href="http://www.schneider-electric.com">www.schneider-electric.com</a> .
2	In the <b>Search</b> box type the reference of a product or the name of a product range. <ul style="list-style-type: none"><li>Do not include blank spaces in the model number/product range.</li><li>To get information on grouping similar modules, use asterisks (*).</li></ul>
3	If you entered a reference, go to the <b>Product Datasheets</b> search results and click on the reference that interests you. If you entered the name of a product range, go to the <b>Product Ranges</b> search results and click on the product range that interests you.
4	If more than one reference appears in the <b>Products</b> search results, click on the reference that interests you.
5	Depending on the size of your screen, you may need to scroll down to see the data sheet.
6	To save or print a data sheet as a .pdf file, click <b>Download XXX product datasheet</b> .

The characteristics that are presented in this manual should be the same as those characteristics that appear online. In line with our policy of constant improvement, we may revise content over time to improve clarity and accuracy. If you see a difference between the manual and online information, use the online information as your reference.

### Related Documents

Title of Documentation	Reference Number
HMIGXO Installation Guide	S1B12059 (Chs and Eng)
Vijeo Designer online help	

You can download these technical publications and other technical information from our website at <http://www.schneider-electric.com/ww/en/download>

 **DANGER**

**HAZARD OF ELECTRIC SHOCK, EXPLOSION OR ARC FLASH**

- Disconnect all power from all equipment including connected devices prior to removing any covers or doors, or installing or removing any accessories, hardware, cables, or wires except under the specific conditions specified in the appropriate hardware guide for this equipment.
- Always use a properly rated voltage sensing device to confirm the power is off.
- Unplug the power cable from both the equipment and the power supply.
- Replace and secure all covers, accessories, hardware, cables, and wires and confirm that a proper ground connection exists before applying power to the equipment.
- Use only the specified voltage when operating this equipment and any associated products.

**Failure to follow these instructions will result in death or serious injury.**

 **WARNING**

**LOSS OF CONTROL**

- Consider the potential failure modes of control paths in the machine control system design, such as:
  - the possibility of backlight failure,
  - unanticipated link transmission delays or failures,
  - the operator being unable to control the machine,
  - the operator making errors in the control of the machine.
- Provide a means to achieve a safe state during and after a path failure for critical control functions such as emergency stop and overtravel stop.
- Provide separate or redundant control paths for critical control functions.
- Test individually and thoroughly each implementation of the panel for correct operation before service.

**Failure to follow these instructions can result in death, serious injury, or equipment damage.**

 **WARNING**

**UNINTENDED EQUIPMENT OPERATION**

- Only use software approved by Schneider Electric for use with this equipment.
- Update your application program every time you change the physical hardware configuration.

**Failure to follow these instructions can result in death, serious injury, or equipment damage.**



---

# Chapter 1

## HMIGXO Panels

---

### Overview

This chapter describes the series of panels and connectable devices.

### What Is in This Chapter?

This chapter contains the following topics:

Topic	Page
Package Contents	10
Parts Identification and Functions	11
Certifications and Standards	13
HMIGXO Series of Panels	14

## Package Contents

### Overview

Make sure all applicable items listed here are included in the panel package:

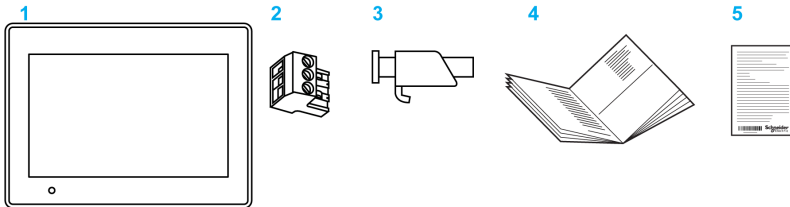

- 1 Panel
- 2 DC power connector
- 3 Screw installation fasteners (HMIGXO3501 and HMIGXO3502 x 4, HMIGXO5502 x 6)
- 4 HMIGXO Installation guide
- 5 HMIGXO Flyer

### Revision

You can identify the product version (PV), revision level (RL), and the software version (SV) from the product label on the panel.

The following diagram is a representation of a typical label:



## Parts Identification and Functions

### HMIGXO Parts Identification

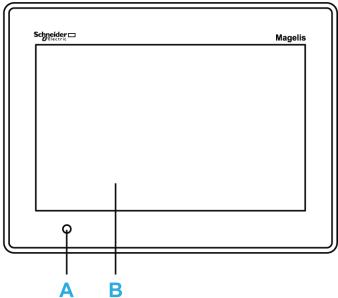
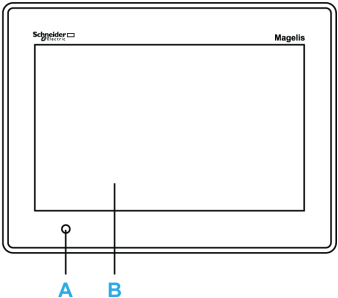
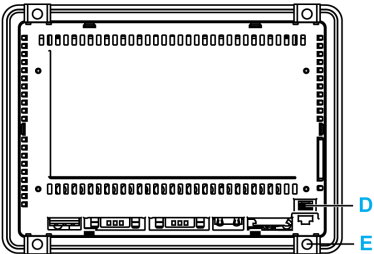
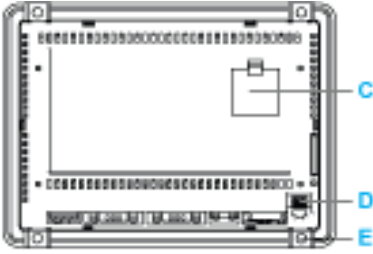
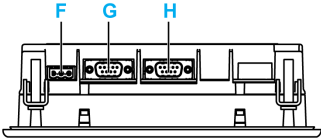
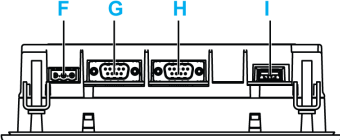
Side	HMIGXO3501	HMIGXO-502
Front		
Rear		
Bottom		

Part	Description
A	LED Indicator
B	Touch panel
C	Replaceable battery for RTC
D	USB (Type mini B)
E	Screw installation fasteners (HMIGXO3501 and HMIGXO3502 x 4, HMIGXO5502 x 6)

<b>Part</b>	<b>Description</b>
F	Power connector
G	Serial Interface COM2 (RS-422/485)
H	Serial Interface COM1 (RS-232C)
I	USB (Type A)

## Certifications and Standards

### Compliance Standards

Schneider-Electric submitted this product for independent testing and qualification by third party listing agencies.

Schneider-Electric and these agencies have certified this product as meeting the following standards:

- Directive 2006/95/EC (Low voltage)
- Directive 2004/108/EC (EMC).

The panels are CE marked.

- EMI: EN61000-6-4
- EMS: EN61000-6-2
- EMS: EN61131-2
- UL50 Type 4 indoor only
- IP65 (front face) - IP20 (rear)

### Qualification Standards

Schneider-Electric voluntarily tested this product to additional standards. The additional tests performed, and the standards under which the tests were conducted, are specifically identified in Environmental Characteristics (*see page 27*).

### Hazardous Substances

The HMIGXO Series are designed for compliance with:

- WEEE, Directive 2002/96/EC
- REACH, Regulation N°1907/2006 on the Registration, Evaluation, Authorisation of Chemicals

This product is compliant with:

- RoHS, Directive 2011/65/EU
- RoHS China, Standard SJ/T 11363-2006

### Hazardous Location

 <b>DANGER</b>
<b>RISK OF EXPLOSION IN HAZARDOUS LOCATION</b>
Do not use this product in hazardous location.
<b>Failure to follow these instructions will result in death or serious injury.</b>

## HMIGXO Series of Panels

### Introduction

The following presents the HMIGXO series of human-machine interface (HMI) products. The features of the screen technology are color and TFT (Thin Film Transistors also known as active matrix) with WVGA pixel resolution. The operating voltage is 24 Vdc. The products offered in this series have various features and benefits listed below:

- Screen size
- RTC battery
- Communication interfaces

### HMIGXO Part Numbers

The following table presents the different HMIGXO panels:

Part number	Screen size	USB type A	USB type mini B	RS-232	RS-422/RS-485	RTC battery
HMIGXO3501	17.78 cm (7 in.)	No	Yes	Yes	Yes	No
HMIGXO3502	17.78 cm (7 in.)	Yes	Yes	Yes	Yes	Yes
HMIGXO5502	25.65 cm (10.1 in.)	Yes	Yes	Yes	Yes	Yes

## Critical Systems, Alarms, and Handling Requirements

Critical alarm indicators and system functions require independent and redundant protection hardware and/or mechanical interlocks.

When you cycle power, wait at least 10 seconds before restoring the power to the panel after it has been turned off. Switching the power OFF and ON quickly can damage the panel.

In the event the screen cannot be properly read, for example, if the backlight is not functioning, it may be difficult or impossible to identify a function. Functions that may present a hazard if not immediately executed, such as a fuel shut-off, must be provided independently of the panel. The machine's control system design must take into account the possibility of the backlight no longer functioning and the operator being unable to control the machine or making mistakes in the control of the machine.

### WARNING

#### LOSS OF CONTROL

- Consider the potential failure modes of control paths in the machine control system design, such as:
  - the possibility of backlight failure,
  - unanticipated link transmission delays or failures,
  - the operator being unable to control the machine,
  - the operator making errors in the control of the machine.
- Provide a means to achieve a safe state during and after a path failure for critical control functions such as emergency stop and overtravel stop.
- Provide separate or redundant control paths for critical control functions.
- Test individually and thoroughly each implementation of the panel for correct operation before service.

**Failure to follow these instructions can result in death, serious injury, or equipment damage.**

### WARNING

#### UNINTENDED EQUIPMENT OPERATION

- Do not use this equipment as the only means of control for critical system functions such as motor start/stop or power control.
- Do not use this equipment as the only notification device for critical alarms, such as device overheating or overcurrent.

**Failure to follow these instructions can result in death, serious injury, or equipment damage.**

## Handling the LCD Panel

The following characteristics are specific to the LCD panel and are considered normal behavior:

- LCD screen may show unevenness in the brightness of certain images or may appear different when seen from outside the specified viewing angle. Extended shadows, or crosstalk may also appear on the edges of screen images.
- LCD screen pixels may contain black and white-colored spots and the color display may look as if it is changing.
- When the same image is displayed on the panel's screen for a long period, an after-image may appear after changing the image. If this happens, turn OFF the panel, wait 10 seconds and then restart the panel.

**NOTE:** Change the screen image periodically and try not to display the same image for a long period of time.

 <b>CAUTION</b>
<b>SERIOUS EYE AND SKIN INJURY</b> The liquid in the LCD panel contains an irritant: <ul style="list-style-type: none"><li>● Avoid direct skin contact with the liquid.</li><li>● Wear gloves when you handle a broken or leaking unit.</li><li>● Do not use sharp objects or tools in the vicinity of the LCD touch panel.</li><li>● Handle the LCD panel carefully to prevent puncture, bursting, or cracking of the panel material.</li></ul> <b>Failure to follow these instructions can result in injury or equipment damage.</b>



If the panel is damaged and any liquid comes in contact with your skin, immediately rinse the area with running water for at least 15 minutes. If the liquid gets in your eyes, immediately rinse your eyes with running water for at least 15 minutes and consult a doctor.



---

# Chapter 2

## Device Connectivity

---

### Introduction

This chapter presents the equipment you can connect to the HMIGXO panel.

### What Is in This Chapter?

This chapter contains the following topics:

Topic	Page
System Design	18
Accessories	22

---

## System Design

### Introduction

The following diagrams represent the main selection of equipments you can connect to the panels.

### Edit Mode Peripherals

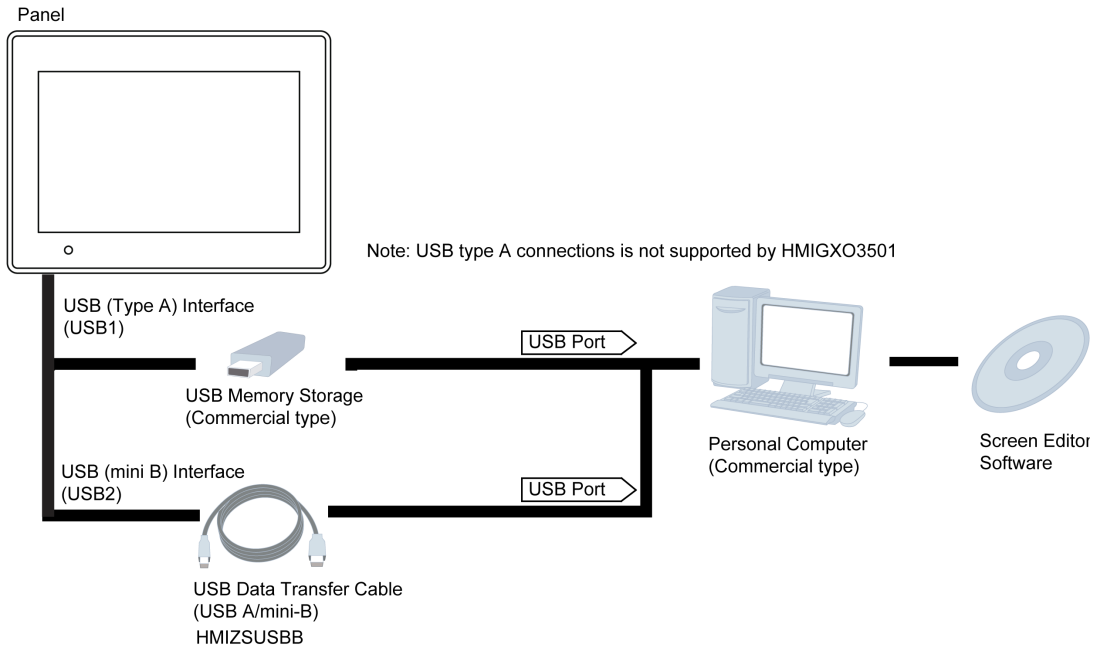

## Run Mode Peripherals - USB Type A/mini B Interface

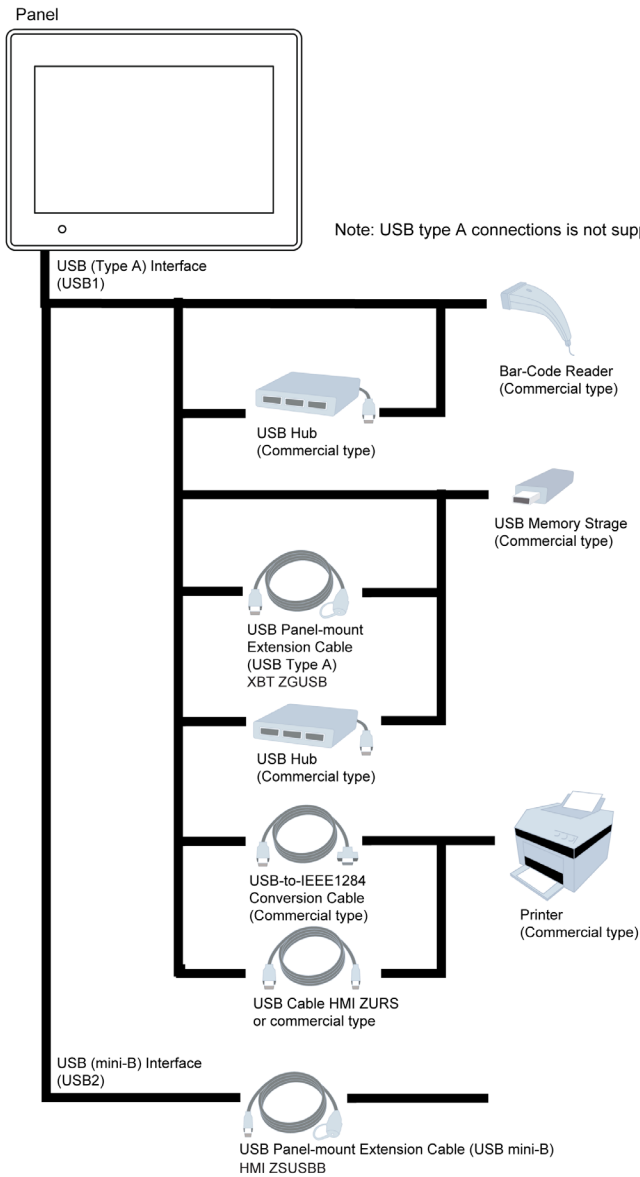



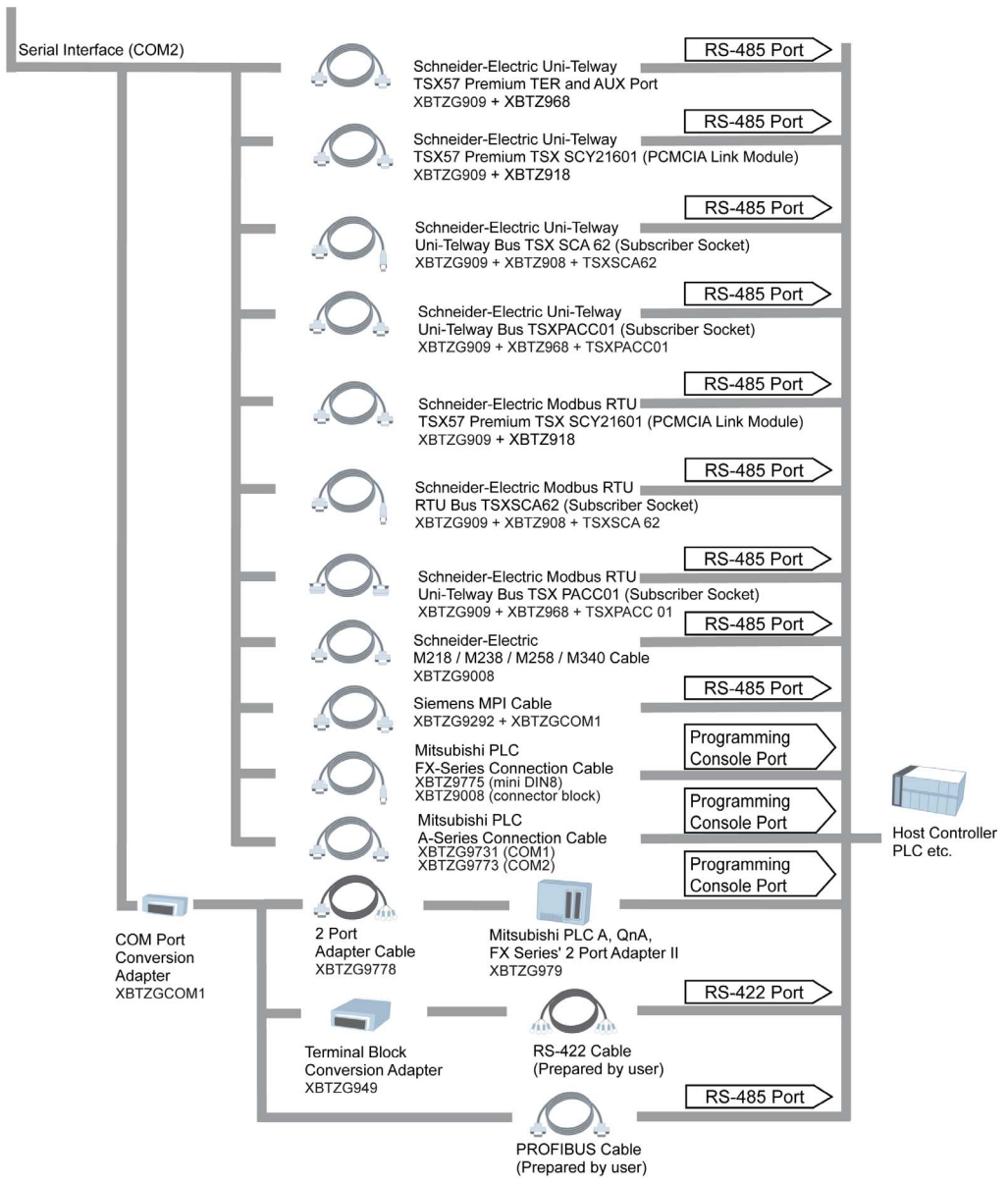

## Accessories

### Serial Interface Items

Product Number	Product Name	Description
XBTZ9008	Cable	Connects HMIGXO (RS-485) to Modicon M218, M238, M258 or M340
XBTZ968		Connects HMIGXO (RS-485) with XBTZG909 adapter to Premium, Micro, Twido PLC
XBTZ908		Connects HMIGXO (RS-232) with XBTZG909 adapter to derivation box TSXSCA62
XBTZ9008		Connects HMIGXO (RS-485) to ATV drives
XBTZ918		Connects HMIGXO (RS-485) with XBTZG909 adapter to Premium SCY
XBTZ988		Connects HMIGXO (RS-232) with XBTZG919 adapter to Advantys STB
XBTZGI232	Isolation	Connects HMIGXO (RS-232/RS-422) to an equipment and provides isolation
XBTZGCOM1	Port adapter	Connects HMIGXO (RS-232) to optional RS-422 equipment
XBTZGCOM2		Connects HMIGXO (RS-485) to optional RS-485 equipment
XBTZG9722	Cable	Connects HMIGXO (RS-422) to RS-422 devices
XBTZG949	Terminal block	Terminal RS-422 block to connect HMIGXO (RS-422), with port adapter to RS-422 devices
TSXPCX1031	XBT Z cable	Multifunction communication cable for the DTE terminal port.
TSXPACC01	Terminal isolation box	Wiring accessory that connects to the TER terminal of TSX37 PLCs via its cable, equipped with a mini-DIN connector at one end.
TSXSCA62	Subscriber socket	Passive 2-channel Uni-Telway subscriber socket.

Product Number	Product Name	Description	Supplier
XBTZG9772	Cable	Connects HMIGXO (RS-232) to PLC Q series link unit	Mitsubishi
XBTZG9773		Connects HMIGXO (RS-422) to PLC A series CPU	
XBTZG9774		Connects HMIGXO (RS-232) to PLC Q series CPU	
XBTZG9775		Connects HMIGXO (RS-422) to PLC FX series CPU	
XBTZG979		Connects HMIGXO (RS-422) with port adapter to PLC with Melsec 2 port adapter	
XBTZG9292		Connects HMIGXO (RS-232) to MPI PLC	Siemens
XBTZ9732		Connects HMIGXO(RS-485) with adapter XBT ZG909 to DH485 PLC	Rockwell
XBTZG9731		Connects HMIGXO (RS-232) to PLC A series link unit or to DF1 Logix PLC	
XBTZG9740 XBTZG9731			Connects HMIGXO (RS-232) to PLC Sysmac Link series

## USB Interface Items

Product Name	Product Number	Description
USB Type A Panel mount extension cable	XBTZGUSB	Extends a USB1 host interface on a cabinet with waterproofness
USB Type A Panel mount conversion cable	HMIZURS	Converts a USB1 host interface to RS-232
USB Type mini B Panel mount extension cable	HMIZSUSBB	Extends a USB2 host interface on a cabinet with waterproofness
USB Data transfer cable type A / mini B	BMXXCAUSBH018	Connects the panel to a USB terminal port of a PC

## Software

Product Name	Description
Vijeo Designer	Software used to create HMI unit project data. It is installed in a personal computer.

---

## Maintenance Options

Product Name	Product Number	Description
Screw installation fastener	XBTZGFIX	Fasteners to attach the panel to a mounting surface. (4 fasteners/pack)
USB STD A holder	HMIZSCPL2	Fastens onto a USB interface and prevents the USB cable from being disconnected.
USB mini B holder	HMIZSCPL4	Fastens onto a USB interface and prevents the USB cable from being disconnected.
Power supply connector	XBTGPW1	Connects the power cord to the panel.
Battery	HMIZSBA1	Replacement battery
Gasket	HMIZS52	Gasket 7.0-inch wide installation gasket
	HMIZS51	Gasket 10.2-inch wide installation gasket



---

# Chapter 3

## Specifications

---

### Overview

This chapter presents the HMIGXO specifications.

### What Is in This Chapter?

This chapter contains the following sections:

Section	Topic	Page
3.1	General Specifications	26
3.2	Functional Specifications	31
3.3	Interface Specifications	34
3.4	Dimensions	41

---

# Section 3.1

## General Specifications

---

### Overview

This section presents HMIGXO general specifications.

### What Is in This Section?

This section contains the following topics:

Topic	Page
Specifications	27
Structural Specifications	30

## Specifications

Specification		Value
Power Supply	Rated input voltage	24 Vdc
	Input voltage limits	20.4...28.8 Vdc
	Acceptable voltage drop	≤ 1 ms with lowest input voltage ≤ 10 ms with rated input voltage
	Power consumption	HMIGXO3501: 5.7 W HMIGXO3502: 8.7 W HMIGXO5502: 11.3 W
	In-rush current	≤ 50 A <sup>1</sup>
	Voltage endurance between power terminal and functional ground (FG)	600 Vac 20 mA for 1 min.
	Insulation resistance between power terminal and FG.	10 MΩ or higher at 500 Vdc
Physical	Ambient operating temperature (cabinet interior & panel face)	0...50 °C (32...122 °F)
	Storage temperature	-20...60 °C (-4...140 °F)
	Relative humidity	85 % w/o condensation (Non condensing, wet bulb temperature 39 °C (102.2 °F) or less)
	Air purity (dust)	≤ 0.1 mg/m <sup>3</sup> (3.5 <sup>-6</sup> oz/ft <sup>3</sup> ) (non-conductive levels)
	Pollution degree	2
	Corrosive gases	Free of corrosive gases
	Atmospheric pressure	800...1,114 hPa (2,000 m (6561 ft) or less)
Mechanical	Vibration immunity	IEC 60068- 2 - 6 5...150 Hz, 3.5 mm (0.38 in) max., 1 g on 3 axes.
	Shock immunity	IEC 60068 - 2 - 27 1/2 sinusoidal pulse for 11 ms, 15 g on 3 axes
Structural	Protection (front panel)	IP 65 - (IEC 60529) Enclosure type 4 indoor use only (UL 50) with screw installation fasteners
	Protection (rear panel)	IP 20 - (IEC 60529)
<sup>1</sup> For in-rush current, the FWHM (full-width, half maximum) value is approximately 50 μs (when exceeding 25 A).		

Specification		Value
Electrical	Radiated radio frequency electromagnetic field	10 V/m / 80 MHz...1 GHz, 3 V/m / 1.4 MHz...2 GHz, 1 V/m / 2 GHz...3 GHz, sinus amplitude modulated 80 % / 1 kHz and internal clock frequency
	Electrical fast transient	EN/IEC 61131-2 Zone B 2 kV power supply and 1 kV shielded cables
	High energy surges	IEC 61000 - 4 - 5 0.5 kV (Differential Mode on power supply) 1 kV (Common Mode on power supply)
	Electrostatic discharge Immunity	EN/IEC 61131-2 4 kV contact, 8 kV air
<sup>1</sup> For in-rush current, the FWHM (full-width, half maximum) value is approximately 50 $\mu$ s (when exceeding 25 A).		

The front face of the panel, installed in a solid panel, has been tested using conditions equivalent to the standards shown in the specification.

## CAUTION

### EQUIPMENT DAMAGE

Ensure that the panel is not in permanent and direct contact with oils.

**Failure to follow these instructions can result in injury or equipment damage.**

## *NOTICE*

### STORAGE AND OPERATION OUTSIDE OF SPECIFICATIONS

- Store the panel in areas where temperatures are within the panel's specifications.
- Do not restrict or block the panel's rear-face ventilation slots.

**Failure to follow these instructions can result in equipment damage.**

## *NOTICE*

### GASKET AGING

- Inspect the gasket periodically as required by your operating environment to keep the initial IP level.
- Change the gasket at least once a year, or as soon as scratches or dirt become visible.

**Failure to follow these instructions can result in equipment damage.**

---

### Air quality requirements

Do not operate or store the panel where any of the following chemicals may evaporate or where these chemicals are present in the air:

- Corrosive chemicals such as acids, alkalines and liquids containing salt.
- Flammable chemicals such as organic solvents.

 <b>CAUTION</b>
<b>INOPERATIVE EQUIPMENT</b> Do not allow water, liquids, metal, and wiring fragments to enter the panel case. <b>Failure to follow these instructions can result in injury or equipment damage.</b>

---

## Structural Specifications

Specification	HMIGXO3501	HMIGXO3502	HMIGXO5502
Grounding	Observe local codes and standards. The ground connection must have a resistance $\leq 0.1 \Omega$ and the ground wire must have a cross section of at least $2 \text{ mm}^2$ (AWG 14).		
External dimensions (W x H x D)	207.8 mm (8.18 in) x 153.2 mm (6.03 in) x 59.8 mm (2.36 in)	207.8 mm (8.18 in) x 153.2 mm (6.03 in) x 59.8 mm (2.36 in)	275.8 mm (10.86 in) x 206.8 mm (8.14 in) x 59.8 mm (2.36 in)
Panel-cut dimensions	Dimensions ( <i>see page 46</i> )		
Cooling Method	Natural air circulation		

---

## Section 3.2

### Functional Specifications

---

#### Overview

This section presents the HMIGXO functional specifications for the display, memory and interfaces.

#### What Is in This Section?

This section contains the following topics:

Topic	Page
Display Specifications	32
Memory, Clock, and Touch Panel	33

## Display Specifications

### Displays

Specification	HMIGXO3501	HMIGXO3502	HMIGXO5502
Type	TFT Color LCD		
Resolution (pixels)	800 x 480 (WVGA)	800 x 480 (WVGA)	800 x 480 (WVGA)
Active display area (W x H)	154.08 x 85.92 mm (6.066 x 3.382 in.)	154.08 x 85.92 mm (6.066 x 3.382 in.)	219.6 x 131.76 mm (8.645 x 5.187 in.)
Colors	65,536 colors		
Backlight Service Life	20,000 hours or more (continuous operation at 25 °C [77 °F] before backlight brightness decreases to 50 %) <b>NOTE:</b> To save the life of the backlight, set the panel in standby mode which automatically turns the backlight off when no touch input is detected within a set time.		
Brightness	16 levels available via touch panel		
System embedded language fonts <sup>(1)</sup>	ASCII: (code page 850) alphanumeric (including European characters) Chinese (simplified): GB2312-80 codes Japanese: ANK 158, Kanji: 6,962 (JIS standards 1 & 2) (including 607 non-kanji characters) Korean: (KSC5601 - 1992 codes) Hangul fonts Chinese (traditional): large 5 codes		
Character sizes <sup>(1)</sup>	8 x 8, 8 x 16, 16 x 16, and 32 x 32 pixel fonts		
Font sizes	Width can be expanded 1, 2, 4, and 8 times. Height can be expanded 1/2, 1, 2, 4, and 8 times.		
8 x 8 pixels	40 characters per row x 30 rows		
8 x 16 pixels	40 characters per row x 15 rows		
16 x 16 pixels	20 characters per row x 15 rows		
32 x 32 pixels	10 characters per row x 7 rows		

**NOTE:** (1) The display font differs depending on which (language) character, or which size you select. Also, if Vijeo Designer software is used, additional high-quality fonts are available with 16 x 16 or larger characters.



---

## Memory, Clock, and Touch Panel

### Memory

The following table describes the memory parameters:

Memory	HMIGXO3501	HMIGXO3502	HMIGXO5502
NAND flash	64 MB	64 MB	64 MB
User application	16 MB	16 MB	16 MB
Backup NVS RAM	–	128 kilobit	128 kilobit
Main memory DDR2	64 MB	64 MB	64 MB

### Clock

Variations in operating conditions and battery life can cause a clock inaccuracy from -380 to +90 seconds per month.

Monitor and adjust the time as needed to satisfy the system requirements. For time-dependent applications, refer to the Vijeo Designer Help for information on synchronizing the panel clock with the PLC clock. To preserve processing time, do not synchronize continually. The clocks can be synchronized approximately twice a day.

### Touch Panel

Specification	HMIGXO series
Service Life	1 million switch and 100 thousand slide operations

---

# Section 3.3

## Interface Specifications

---

### Overview

This section presents the interface specifications of the panels.

### What Is in This Section?

This section contains the following topics:

Topic	Page
Interface Specifications	35
Serial Interface Specifications COM1	37
Serial Interface Specifications COM2	39

---

## Interface Specifications

### Introduction

All HMIGXO panels are provided with serial and USB Interfaces.

### Serial Interface COM1

The following table describes the COM1 serial interface:

Interface	Description
Serial interface D-Sub9	
Asynchronous transmission	RS-232C
Data length	7 or 8 bits
Stop bit	1 or 2 bits
Parity	none, odd or even
Data transmission speed	2,400...115,200 bps

### Serial Interface COM2

The following table describes the COM2 serial interface:

Interface	Description
Serial interface D-Sub9	
Asynchronous transmission	RS-422/485
Data length	7 or 8 bits
Stop bit	1 or 2 bits
Parity	none, odd or even
Data transmission speed	2,400 bps to 187.5 Kbps

---

## USB Interface (USB Peripherals)

The following table describes the USB type A interface:

Interface		Description
Host interface		
Transmission speed	high speed	480 Mbps
	full speed	12 Mbps
	low speed	1.5 Mbps
Maximum current supplied		500 mA
Maximum transmission distance		5 m (16.40 ft) at 12 Mbps
Connector		USB Type A V2.0

## USB Interface (Application Download)

USB mini B V2.0 type connector is used for application download.

## Serial Interface Specifications COM1

### Introduction

This interface is used to connect HMIGXO series to remote equipment, via an RS-232C cable. The connector used is a D-Sub 9-pin male connector.

By using a long PLC cable to connect to the panel, it is possible that the cable can be at a different electrical potential than the panel, even if both are grounded.

The panel's serial port is not isolated. The SG (signal ground) and the FG (functional ground) terminals are connected inside the panel.

## DANGER

### ELECTRIC SHOCK

- Make a direct connection between the functional ground (FG) terminal and ground.
- Do not connect other devices to ground through the functional ground (FG) terminal of this device.
- Install all cables according to local codes and requirements. If local codes do not require grounding, follow a reliable guide such as the US National Electrical Code, Article 800.

**Failure to follow these instructions will result in death or serious injury.**

### Serial Interface COM1

The following table describes the serial interface with a D-Sub 9 pin connector via an RS-232C cable.

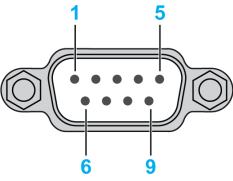
Pin Connection	Pin	Signal Name	Direction	Meaning
	1	CD	Input	Carrier Detect
	2	RD(RXD)	Input	Receive Data
	3	SD(TXD)	Output	Send Data
	4	ER(DTR)	Output	Data Terminal Ready
	5	SG	-	Signal Ground
	6	DR(DSR)	Input	Data Set Ready
	7	RS(RTS)	Output	Request to Send
	8	CS(CTS)	Input	Send possible
	9	Reserved	Input	-
	Shell	FG	-	Functional Ground (Common with SG)

---

Any excessive weight or stress on communication cables disconnect communication with the equipment.

 **CAUTION**

**LOSS OF POWER**

- Make sure all connections to the communication ports on the bottom and sides of the panel do not put excessive stress on the ports.
- Securely attach communication cables to the panel or cabinet.
- Use only D-Sub 9 pin cables with a locking system in good condition.

**Failure to follow these instructions can result in injury or equipment damage.**

## Serial Interface Specifications COM2

### Introduction

This interface is used to connect the HMIGXO series to the remote equipment, via an RS-422/485 cable. The connector used is a D-Sub 9-pin male connector.

By using a long PLC cable to connect to the panel, it is possible that the cable can be at a different electrical potential than the panel, even if both are grounded.

The panel's serial port is not isolated. The SG (signal ground) and the FG (functional ground) terminals are connected inside the panel.

## DANGER

### ELECTRIC SHOCK

- Make a direct connection between the functional ground (FG) terminal and ground.
- Do not connect other devices to ground through the functional ground (FG) terminal of this device.
- Install all cables according to local codes and requirements. If local codes do not require grounding, follow a reliable guide such as the US National Electrical Code, Article 800.

**Failure to follow these instructions will result in death or serious injury.**

### Serial Interface COM2

The following table describes the serial interface with a D-Sub 9-pin connector via an RS-422/485 cable.

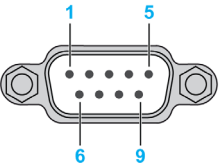
Pin Connection	Pin	Signal Name	Direction	Meaning
	1	RDA	Input	Receive Data A (+)
	2	RDB	Input	Receive Data B (-)
	3	SDA	Output	Send Data A (+)
	4	ERA	Output	Data Terminal Ready A (+)
	5	SG	-	Signal Ground
	6	CSB	Input	Send Possible B (-)
	7	SDB	Output	Send Data B (-)
	8	CSA	Input	Send Possible A (+)
	9	ERB	Output	Data Terminal Ready B (-)
	Shell	FG	-	Functional Ground (Common with SG)

---

Any excessive weight or stress on communication cables may disconnect communication with the equipment.

 **CAUTION**

**LOSS OF POWER**

- Make sure all connections to the communication ports on the bottom and sides of the panel do not put excessive stress on the ports.
- Securely attach communication cables to the panel or cabinet.
- Use only D-Sub 9 pin cables with a locking system in good condition.

**Failure to follow these instructions can result in injury or equipment damage.**



---

# Section 3.4

## Dimensions

---

### Overview

This section presents the dimensions of HMIGXO panels.

### What Is in This Section?

This section contains the following topics:

Topic	Page
HMIGXO350• Dimensions	42
HMIGXO5502 Dimensions	44
Panel-cut Dimensions	46
Installation Fasteners	47

## HMIGXO350• Dimensions

### Panel Dimensions

The following figure shows the panel dimensions:

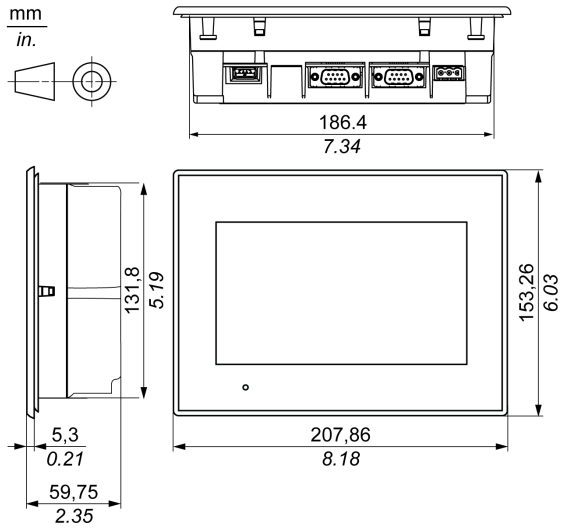

### Dimensions with Cables

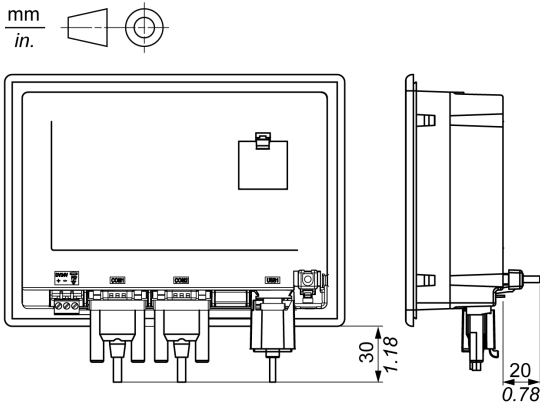

---

## Dimensions with Screw Fasteners

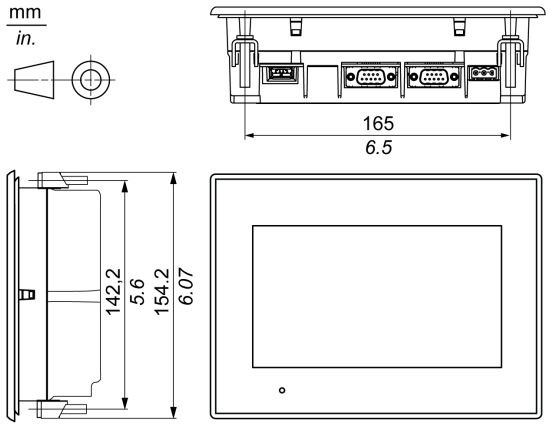

## HMIGXO5502 Dimensions

### Panel Dimensions

The following figure shows the panel dimensions:

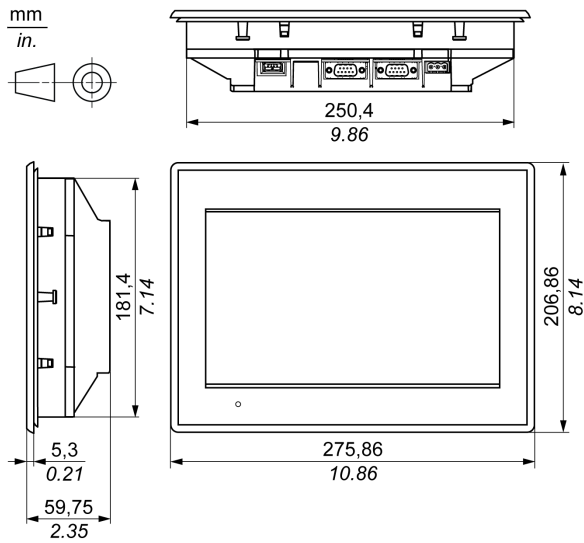

### Dimensions with Cables

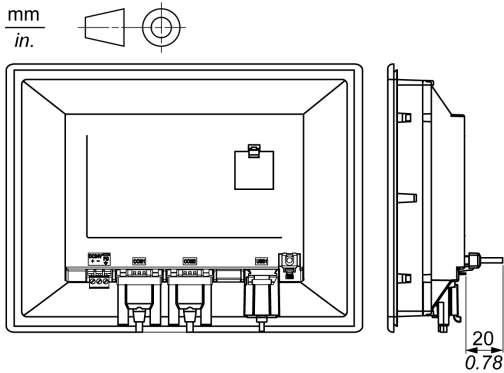

## Dimensions with Screw Fasteners

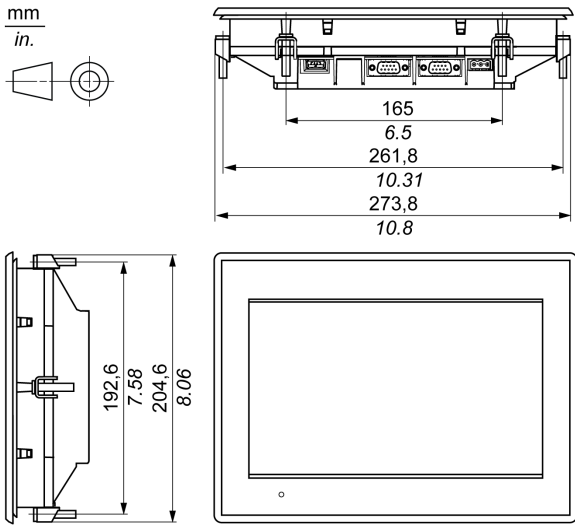

## Panel-cut Dimensions

### Inserting a HMIGXO

Create a panel-cut and insert the panel from the front. The following illustration shows the panel-cut for the HMIGXO series:

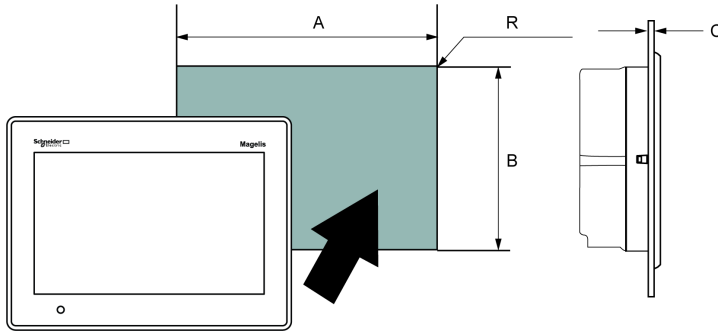

### Dimensions

The following table shows the panel-cut dimensions for each panel:

Model	A	B	C (Panel Thickness)	R
HMIGXO350•	190 $\pm$ 1 mm (7.48 $\pm$ 0.04 in)	135 $\pm$ 0.7 mm (5.31 $\pm$ 0.03 in)	1.5...10 mm (0.06...0.39 in)	3 mm (0.12 in) max.
HMIGXO5502	255 $\pm$ 1.8 mm (10.04 $\pm$ 0.07 in)	185 $\pm$ 1 mm (7.28 $\pm$ 0.04 in)	1.5...10 mm (0.06...0.39 in)	3 mm (0.12 in) max.

---

## Installation Fasteners

### Introduction

The fasteners are used to mount the HMIGXO series:

Model	Screw Installation Fasteners
HMIGXO350•	4
HMIGXO5502	6

### Dimensions

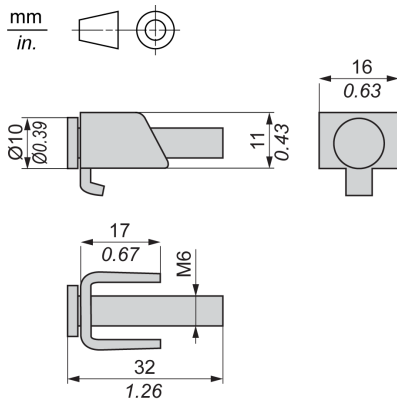





---

# Chapter 4

## Installation and Wiring

---

### Overview

This chapter describes the installation procedures and wiring principles for HMIGXO.

### What Is in This Chapter?

This chapter contains the following sections:

Section	Topic	Page
4.1	Installation	50
4.2	Wiring Principles	57
4.3	USB Port	65

---

# Section 4.1

## Installation

---

### Overview

This section describes the installation procedures for HMIGXO.

### What Is in This Section?

This section contains the following topics:

Topic	Page
Installation Procedures	51
Real Time Clock (RTC)	55

---

## Installation Procedures

### Introduction

The installation gasket and screw fasteners are required when installing the panel.

Mount the panel in an enclosure that provides a clean, dry, robust, and controlled environment (IP65 enclosure) (*see page 27*).

**NOTE:** The protection level of the product may vary from that which is shown on the label, as the value on the label takes into account product aging.

An old gasket can lose its dust and drip resistance. Changing the gasket once a year or when scratches or dirt becomes visible is recommended.

### Gasket Setup Requirements

The gasket helps maintain the protection ratings (IP65, IP20) of the panel, and provides additional protection from vibration.

Stage	Description
1	Before installing the panel into a cabinet, check that the installation gasket is securely attached to the panel.
2	A gasket which has been used for a long period may have scratches or dirt on its surface, and could have lost much of its dust and drip resistance. Change the gasket once a year or when scratches or dirt become visible.
3	Make sure that the gasket is inserted into the panel bottom face.

### Panel Setup Procedure

Stage	Description
1	Check that the installation panel or the surface of the cabinet is flat, in good condition and has no jagged edges. Metal reinforcing strips may be attached to the inside of the panel wall, near the panel-cut, to increase the rigidity of the panel.
2	Decide on the installation the thickness of the panel based on the level of panel strength required: 1.5 mm (0.06 in) to 10 mm (0.4 in).
3	Be sure that the ambient operation temperature and the ambient humidity are within their designated ranges. (When installing the panel in a cabinet or enclosure, the ambient operation temperature is the internal temperature of the cabinet or enclosure.)
4	Be sure that heat from surrounding equipment does not cause the panel to exceed its standard operating temperature ( <i>see page 27</i> ).

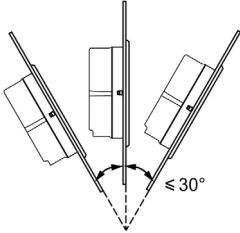
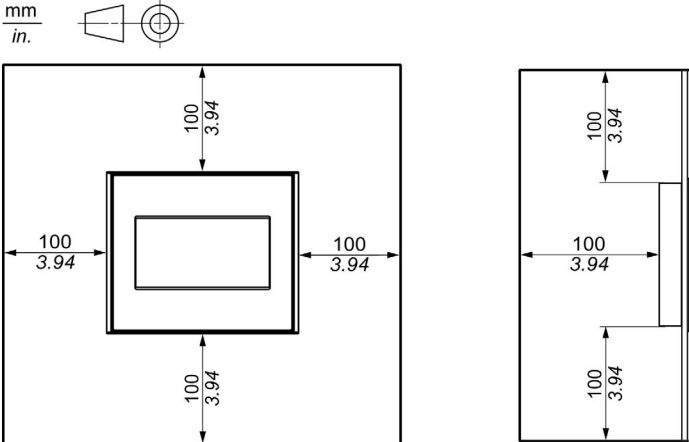
Stage	Description
5	<p>When installing the panel in a slanted position, the panel face should not incline more than 30°.</p>  <p>When installing the panel in a slanted position, and the panel face inclines more than 30°, the ambient temperature must not exceed 40 °C (104 °F). You may need to use forced air cooling (fan, A/C) to ensure that the ambient operating temperature is 40°C or below.</p>
6	<p>For easier maintenance, operation and improved ventilation, install the panel at least 100 mm (3.94 in) away from adjacent structures and other equipment as shown in the following illustration.:</p>  <p>mm in.</p>

## Panel Mounting Procedure

### NOTICE

#### PANEL UNSTEADY WHEN UNSECURED

Keep panel stabilized in the panel-cut while you are installing or removing the screw fasteners.

**Failure to follow these instructions can result in equipment damage.**

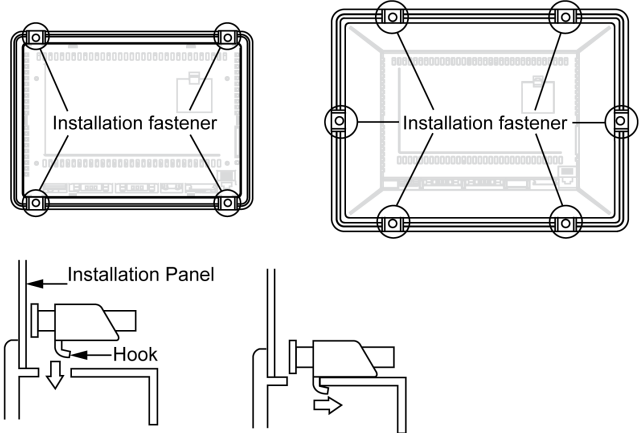
Step	Action
1	Place the panel on a clean and level surface with the display face pointing downward.
2	Check that the installation gasket ( <i>see page 51</i> ) of the panel is seated securely which runs around the perimeter of the frame.
3	Create the correct sized opening required to install the panel, using the installation dimensions ( <i>see page 41</i> ).
4	Insert the panel into the panel-cut.
5	<p>Insert the installation fasteners into the panel's insertion slots on the top and bottom side (and left and right sides for the HMIGXO5502). Slide the fasteners flat against the panel. If the fasteners are not correctly attached, the panel may shift or fall out.</p> 

---

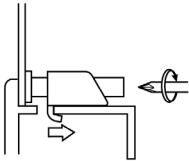
Step	Action
6	<p>Use a Phillips screwdriver to tighten each fastener and secure the panel in place. The necessary torque is 0.8...1 Nm (7.08...8.85 lb-in):</p> 

## ***NOTICE***

### **BROKEN ENCLOSURE**

Do not exert more than 1 Nm (8.85 lb-in) of torque when tightening the fastener's screws.

**Failure to follow these instructions can result in equipment damage.**

---

## Real Time Clock (RTC)

### Overview

HMIGXO panels include a RTC to provide system date and time information, and to support related functions requiring a real-time clock. To continue to keep time when power is off, a non-rechargeable but replaceable battery is provided with HMIGXO3502 and HMIGXO5502 panels.

**NOTE:** The HMIGXO3502 and HMIGXO5502 have an inner protective circuit which can sustain it for 2 minutes when exchanging the RTC battery.

### Installing and Replacing the RTC Battery

While lithium batteries are preferred due to their slow discharge and long life, they can present hazards to personnel, equipment and the environment, and must be handled properly.

## DANGER

### EXPLOSION, FIRE, OR CHEMICAL HAZARD

Follow these instructions for the lithium batteries:

- Replace with identical type.
- Follow all battery manufacturer's instructions.
- Remove all replaceable batteries before discarding panel.
- Recycle or properly dispose of used batteries.
- Protect battery from any potential short circuit.
- Do not recharge, disassemble, heat above 100 °C (212 °F), or incinerate.
- Use your hands or insulated tools to remove or replace the battery.
- Maintain proper polarity when inserting and connecting a new battery.

**Failure to follow these instructions will result in death or serious injury.**

**NOTE:** Replace battery only with identical type: Renata type CR2032.

To install or replace the RTC battery, follow these steps:

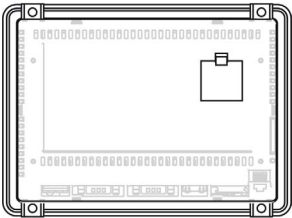
Step	Action
1	Power off your panel.
2	Open the cover to access the backup battery compartment as shown: 
3	Remove the used battery from the compartment.
4	Insert the new battery in the compartment in accordance with the polarity markings in the compartment and on the battery.
5	Close the cover and verify that the latch clicks into place.
6	Power up your HMIGXO. <b>NOTE:</b> If you do not power up your HMIGXO immediately, the external backup battery life might be reduced.
7	Set the internal clock. For further details on the internal clock, refer to Set Terminal Clock. (see Vijeo-Designer Online Help).
A lithium battery life is: <ul style="list-style-type: none"> <li>● 3 years when the battery's ambient temperature is <math>\leq 40</math> °C (104 °F).</li> <li>● 3 years when the panel's ambient temperature is <math>\leq 25</math> °C (77 °F).</li> </ul>	

**NOTE:** Replacement of the panel's battery other than with the type specified in this documentation may present a risk of fire or explosion.



---

## Section 4.2

### Wiring Principles

---

#### Overview

This section presents HMIGXO wiring principles.

#### What Is in This Section?

This section contains the following topics:

Topic	Page
Connecting the Power Cord	58
Connecting the Power Supply	61
Grounding	63

---

## Connecting the Power Cord

### Introduction

Follow these instructions when supplying power to the panel.

- When the functional ground (FG) terminal is connected, be sure the wire is grounded. Not grounding the panel can result in excessive Electromagnetic Interference (EMI). Grounding is required to meet EMC level immunity.
- The shield ground (SG) and FG terminals are connected internally in the panel.
- Disconnect the power before wiring the panel's power terminals.
- The panel uses only 24 Vdc power. Using any other level of power can damage both the power supply and the panel.
- Since the panel is not equipped with a power switch, be sure to connect a power switch to the panel's power supply.
- Be sure to ground the panel's FG terminal.

### Power Cord Preparation

- Make sure the ground wire is either the same or heavier gauge than the power wires.
- Do not use aluminum wires in the power supply's power cord.
- If the ends of the individual wires are not twisted correctly, the wires may create a short circuit. To avoid this, use D25CE/AZ5CE cable ends.
- Wherever possible, use wires that are 0.75 to 2.5 mm<sup>2</sup> (AWG 18 - 12) for the power cord, and twist the wire ends before attaching the terminals.
- The conductor type is solid or stranded wire.

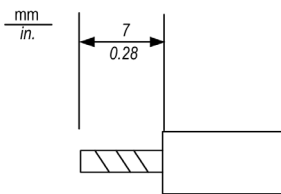

## Power Plug Illustration

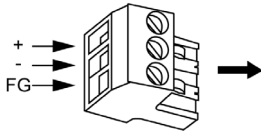

Connection	Wire
+	24 Vdc
-	0 Vdc
FG	Grounded terminal connected to the panel chassis.

## How to connect the Power Cord

The following table explains how to connect the power plug:

Step	Action
1	Remove the power cord from the power supply.
2	Remove the power plug from the panel.
3	Remove 7 mm (0.28 in.) of the vinyl cover off the ends of the power cord wires.
4	If using stranded wire, twist the ends. Tinning the ends with solder reduces risk of fraying and ensures good electrical transfer.
5	Connect the wires to the power plug by using a flat-bladed screwdriver (size 0.6 X 3.5).
6	Tighten the mounting screws using the defined torque: 0.5...0.6 Nm (5...7 lb-in).
7	Replace the power plug onto the power connector.

### NOTE:

- Do not solder the wire directly to the power receptacle pin.
- The power supply cord should meet the specification shown above. Be sure to twist the power cords together, up to the power plug, for EMC cancellation (see illustration as shown below).

---

## Example of Power Cord Connection

The following illustration shows a connection example of the power cord:

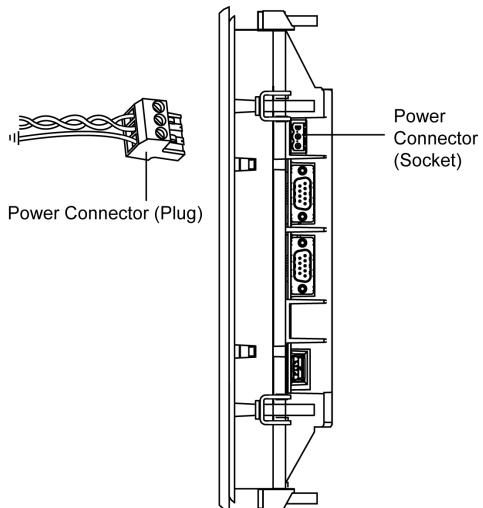

---

## Connecting the Power Supply

### Precautions

- Connect the power cord to the power connector on the side of the panel using the power plug.
- Between the line and the ground, be sure to use a regulated power supply with a Class 2 power supply.
- To increase the electromagnetic noise resistance, be sure to twist the ends of the power cord wires before connecting them to the power plug.
- The panel's power supply cord should not be bundled with or kept close to main circuit lines (high voltage, high current), or input/output signal lines.
- Connect a lightning surge absorber to handle power surges.
- To reduce electromagnetic noise, make the power cord as short as possible.

Excessive stress on the power connection or attempting to install a panel with the power cables connected may disconnect or cause damage to the power connections, which can cause short circuits, fire or unintended equipment operation.

### **WARNING**

#### **SHORT CIRCUITS, FIRE, OR UNINTENDED EQUIPMENT OPERATION**

Avoid excessive force on the power cable to prevent accidental disconnection:

- Securely attach power cables to the panel or cabinet.
- Use the torque 0.5 Nm (4.4 lb-in) to tighten the panel's terminal block screws.
- Install and fasten panel on installation panel or cabinet prior to connecting Power Supply and Communication lines.

**Failure to follow these instructions can result in death, serious injury, or equipment damage.**

## Power Supply Connections

For ease of maintenance, use the following connection diagram to set up your power supply connections.

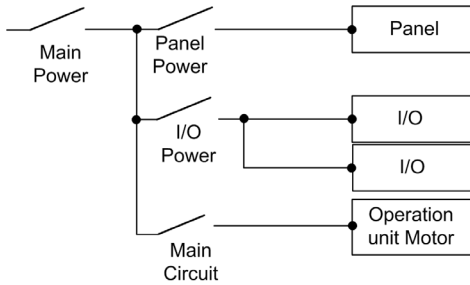

### NOTE:

- Ground the surge absorber (E1) separately from the panel (E2).
- Select a surge absorber that has a maximum circuit voltage greater than that of the peak voltage of the power supply.

The following shows a lightning surge absorber connection:

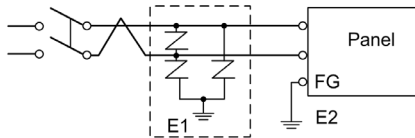

---

## Grounding

### Exclusive Grounding

Take the following precautions for grounding the panel. Connect the functional ground (FG) terminal on the power plug to an exclusive ground.

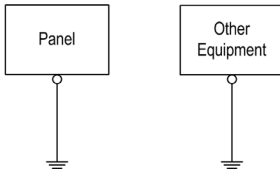

### Grounding Procedure

Step	Action
1	Check that the grounding resistance is less than $0.1 \Omega$ <sup>(1)</sup> .
2	The FG wire should have a cross sectional area greater than $2 \text{ mm}^2$ <sup>(1)</sup> . Create the connection point as close to the panel as possible, and make the wire as short as possible. When using a long grounding wire, replace the thin wire with a thicker wire, and place it in a duct.
3	If the equipment does not function properly when grounded, disconnect the ground wire from the FG terminal.
<sup>(1)</sup> Observe local codes and standards. Ensure the ground connection has a resistance of less than $0.1 \Omega$ and that the ground wire has a cross-section of at least $2 \text{ mm}^2$ or AWG 14.	

---

## Common Grounding

Take the following precautions for grounding the panel.

Electromagnetic Interference (EMI) can be created if the devices are improperly grounded. EMI can cause loss of communication.

Do not use common grounding, except for the authorized configuration described below.

If exclusive grounding is not possible, use a common connection point.

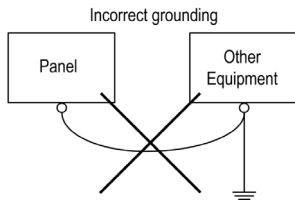
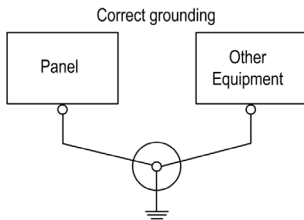



---

## Section 4.3

### USB Port

---

#### Overview

This section presents the USB port.

#### What Is in This Section?

This section contains the following topics:

Topic	Page
Important Considerations When Using the USB Port	66
USB Data Transfer Cable (BMXXCAUSBH018)	67
USB Holder Type A	69
USB Type Mini B	71

---

## Important Considerations When Using the USB Port

### Introduction

The following panels have a USB type A port:

- HMIGXO3502
- HMIGXO5502

The following panels have a USB type mini B port:

- HMIGXO3501
- HMIGXO3502
- HMIGXO5502

You can connect the data transfer cable (BMXXCAUSBH018) to the USB port to transfer data from the computer to the panel.

---

## USB Data Transfer Cable (BMXXCAUSBH018)

### Important Information

Follow the procedure described below to prevent damage to the cable connector or panel.

- Do not connect the USB data transfer cable until told to do so in the instructions.
- When connecting the USB data transfer cable to the computer or to the panel, insert the cable's connector at the correct 90° angle.
- When disconnecting the cable, make sure to hold the connector, not the cable itself.
- If the cable is unplugged from the port during installation and connected to a different port, the operating system will not recognize the new port. Therefore, make sure to always use the designated port.
- If the installation does not complete successfully, restart the computer and quit all resident applications before re-installing the software.

### Post-Installation Check

Perform the following check after installation:

Step	Action
1	On the target machine, make sure the USB cable is physically connected to the USB port.
2	On the PC, make sure the USB cable is physically connected to the USB port.
3	On the desktop, right-click <b>My Computer</b> and click <b>Properties</b> .
4	In the <b>System Properties</b> dialog box, select the <b>Hardware</b> tab, and then click <b>Device Manager</b> .
5	In the Device Manager, the USB link cable (BMXXCAUSBH018) should display below the USB controller.

---

## Troubleshooting

Symptom	Solution
The USB cable is not recognized.	Connect the cable correctly, or restart your PC. Also, when connecting a USB hub, make sure to connect it directly to your PC's USB port.
Overcurrent occurred	
The Plug and Play is not functioning correctly.	
You are unable to use the USB cable after connecting it to a USB hub.	The power supplied from the hub may be insufficient. Make sure the hub is self-powered.
	Connect the cable directly to the PC USB port.
After installation, a ? is displayed when you try to confirm the cable's status via the Device Manager.	The driver has not been installed correctly. Uninstall the driver and re-install it.

## USB Holder Type A

### Introduction

When using a USB device, attaching a USB holder to the USB interface on the side of the panel helps prevent the USB cable from being disconnected.

### Attaching the USB Holder

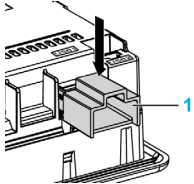
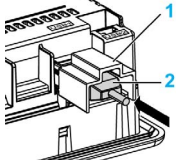
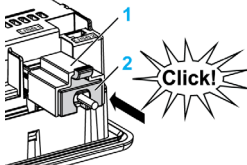
Step	Action
1	<p>Attach the USB holder to the USB Host Interface on the main panel. Hook the upper pick of the USB holder to the attachment hole of the main panel, and insert the lower pick as shown below to fix the USB holder.</p>  <p>1 USB holder</p>
2	<p>Insert the USB cable into the USB host interface.</p>  <p>1 USB holder 2 USB cable</p>
3	<p>Attach the USB cover to fix the USB cable in place. Insert the USB cover into the tab of the USB holder.</p>  <p>1 USB holder 2 USB cover</p>

---

## Removing the USB Holder

Lift up the tab of the USB holder and then remove the USB cover.

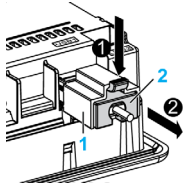

- 1 USB holder
- 2 USB cover

## USB Type Mini B

### Introduction

When using a USB device, you can attach a USB holder to the USB interface on the side of the unit to prevent the USB cable from being disconnected.

### Attaching the USB Holder

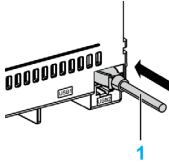
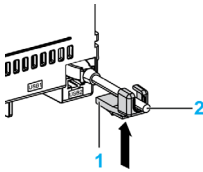
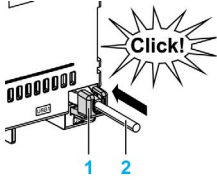
Step	Action
1	<p>Insert the USB cable into the USB host interface.</p>  <p>1 USB cable</p>
2	<p>Attach the USB holder to fix the USB cable in place.</p>  <p>1 USB holder 2 USB cable</p>
3	<p>Insert the USB holder into the tab.</p>  <p>1 USB holder 2 USB cable</p>

---

## Removing the USB Holder

Squeeze the tab of the USB holder and then remove the USB holder.

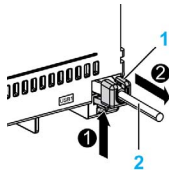

- 1 USB holder
- 2 USB cable



---

# Chapter 5

## Maintenance

---

### Overview

This chapter explains how to maintain your HMIGXO.

### What Is in This Chapter?

This chapter contains the following topics:

Topic	Page
Regular Cleaning	74
Periodic Check Points	75

---

## Regular Cleaning

### Cleaning the Display

#### ***NOTICE***

##### **EQUIPMENT DAMAGE**

- Power off the unit before cleaning it.
- Do not use hard or pointed objects to operate the touch panel, since it can damage the panel surface.
- Do not use paint thinner, organic solvents, or a strong acid compound to clean the unit.

**Failure to follow these instructions can result in equipment damage.**

When the surface or the frame of the display gets dirty, soak a soft cloth in water with a neutral detergent, wring the cloth tightly, and wipe the display.

Do not use paint thinner, organic solvents, or a strong acid compound to clean the unit.

### Cleaning the Gasket

The gasket protects the panel and improves its water resistance.

#### ***NOTICE***

##### **GASKET AGING**

- Inspect the gasket periodically as required by your operating environment to keep the initial IP level.
- Change the gasket at least once a year, or as soon as scratches or dirt become visible.

**Failure to follow these instructions can result in equipment damage.**

During normal maintenance and reinstallation, check the gasket for dirt and scratches.

### Inserting the Gasket

Insert the gasket correctly into the groove to comply with IP65.

---

## Periodic Check Points

### Operation Environment

- The operating temperature should be within the allowable range (0 °C to 50 °C) (32 °F to 122 °F).
- The operating humidity should be within the specified range.
- The operating atmosphere should be free of corrosive gases.

### Electrical Specifications

The input voltage should be within 20.4 to 28.8 Vdc.

### Related Items

- Are all power cords and cables connected properly? Have any become loose?
- Are all mounting brackets holding the unit securely?
- Are there many scratches or traces of dirt on the installation gasket?





## Symbols

peripherals  
  edit mode, *18*  
  run mode, *19, 20*

## A

accessories, *22*

## C

certifications and standards, *13*  
clock, *33*  
connecting the power cord, *58*  
connecting the power supply, *61*

## D

dimensions, *42, 44*

## E

edit mode peripherals, *18*

## F

fasteners, *47*

## G

grounding, *63*

## I

installation  
  fasteners, *47*  
  procedures, *51*

## M

maintenance  
  check points, *75*  
  cleaning, *74*  
memory, *33*

## P

panel-cut dimensions, *46*  
parts identification and functions, *11*  
power plug, *59*

## R

run mode peripherals, *19, 20*

## S

specifications, *27*  
  COM, *37*  
  COM1, *35, 37*  
  COM2, *35, 39*  
  display, *32*  
  interfaces, *35*  
  structural, *30*  
  USB, *36*

## T

touch panel, *33*

## U

USB  
  data transfer cable, *67*  
  holder type A, *69*  
  holder type mini B, *71*  
  port, *66*

