

Low voltage electrical distribution

# Masterpact NT

Circuit breakers and switch-disconnectors  
IEC from 630 to 1600 A

User manual  
04/2016





---

<b>Identifying Masterpact</b>	<b>2</b>
Rating plate	2
<b>Discovering Masterpact</b>	<b>4</b>
Components	4
<b>Using Masterpact</b>	<b>8</b>
Understanding the controls and indications	8
Charging the circuit breaker	9
Closing the circuit breaker	10
Opening the circuit breaker	11
Resetting after a fault trip	12
Locking the controls	13
<b>Using the Masterpact drawout chassis</b>	<b>16</b>
Identifying the circuit breaker positions	16
Racking	17
Matching a Masterpact circuit breaker with its chassis	20
Locking the switchboard door	21
Locking the circuit breaker in position	22
Locking the safety shutters	25
<b>Identifying the electrical auxiliaries</b>	<b>26</b>
Identification of the connection terminals	26
Operation	27
Electrical diagrams	28
<b>Discovering Masterpact's accessories</b>	<b>30</b>
Micrologic control units	30
Indication contacts	31
Auxiliaries for remote operation	33
Device mechanical accessories	36
Chassis accessories	38
<b>Inspecting and testing before use</b>	<b>40</b>
Initial tests	40
What to do when the circuit breaker trips	41
<b>Maintaining Masterpact performance</b>	<b>42</b>
Recommended maintenance program	42
Troubleshooting and solutions	44
<b>Checking Masterpact operating conditions</b>	<b>46</b>
Environmental conditions	46

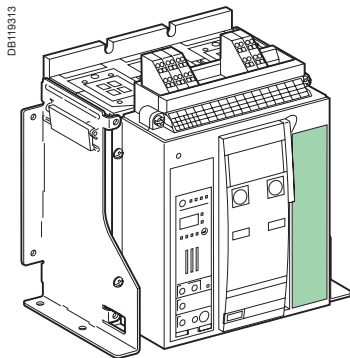

DB110314

<b>Masterpact</b>	
<b>NT12 H1</b>	<b>X</b>
<b>Ui</b> 1000V	<b>Uimp</b> 12kV
<b>Ue</b> (V)	<b>Icu</b> (kA)
220/440 ~	42
480/690 ~	42
<b>Ics</b> 100% Icu	
<b>Icw</b> 42kA/1s	<b>cat.B</b>
IEC 60947-2 50/60Hz	
UTE VDE BS CEI UNE AS NEMA	



Masterpact circuit breakers are available in drawout and fixed versions. The drawout version is mounted on a chassis and the fixed version is installed using fixing brackets.

## Drawout version

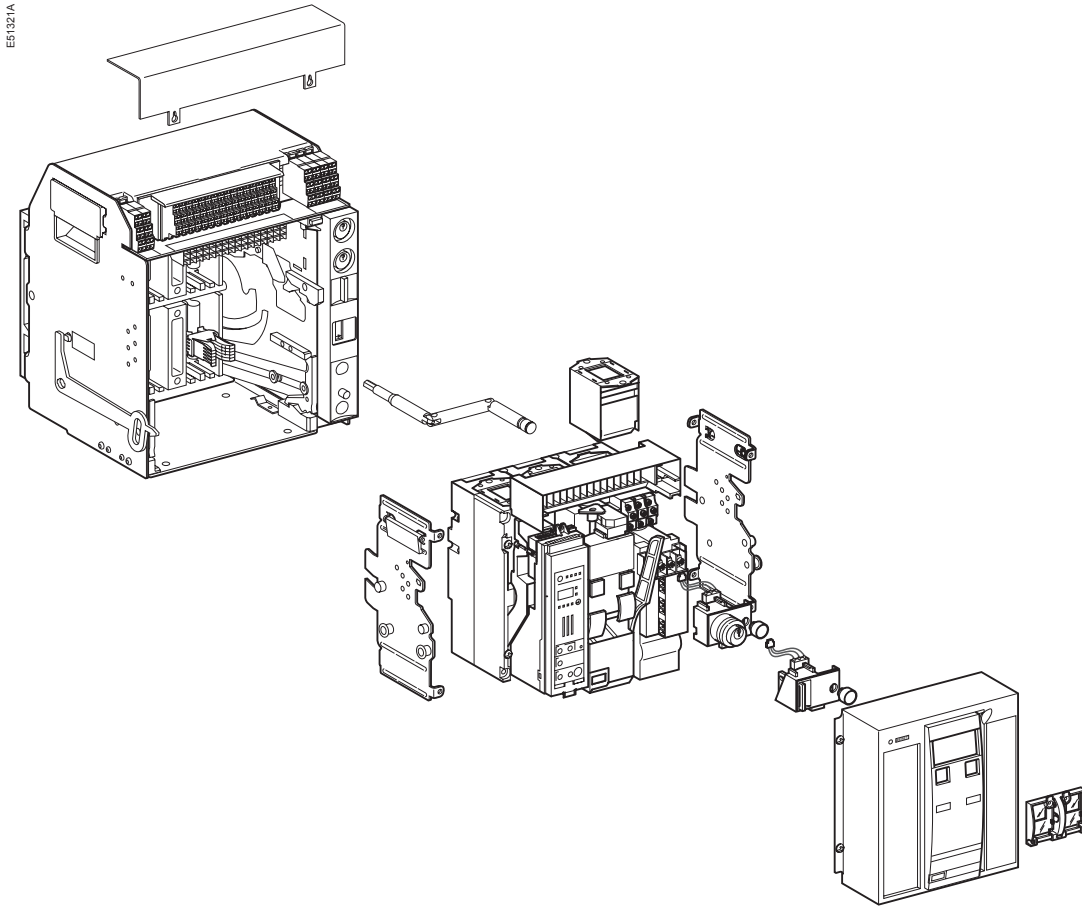

## Fixed version

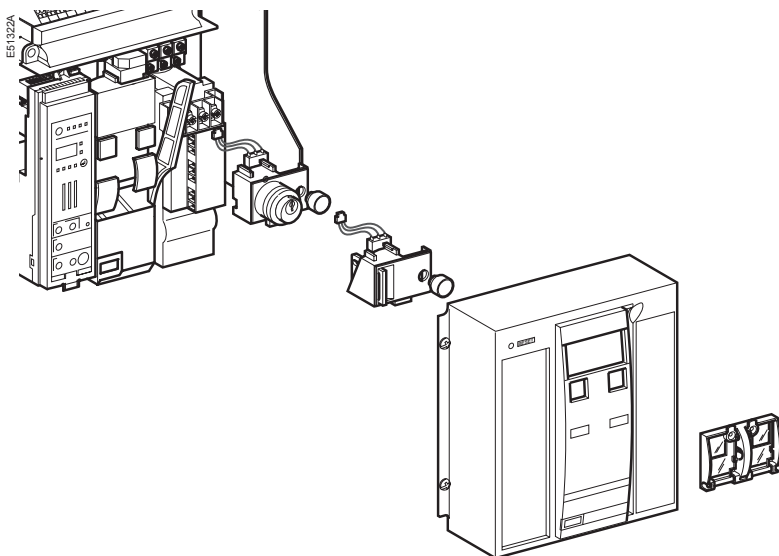

## Chassis

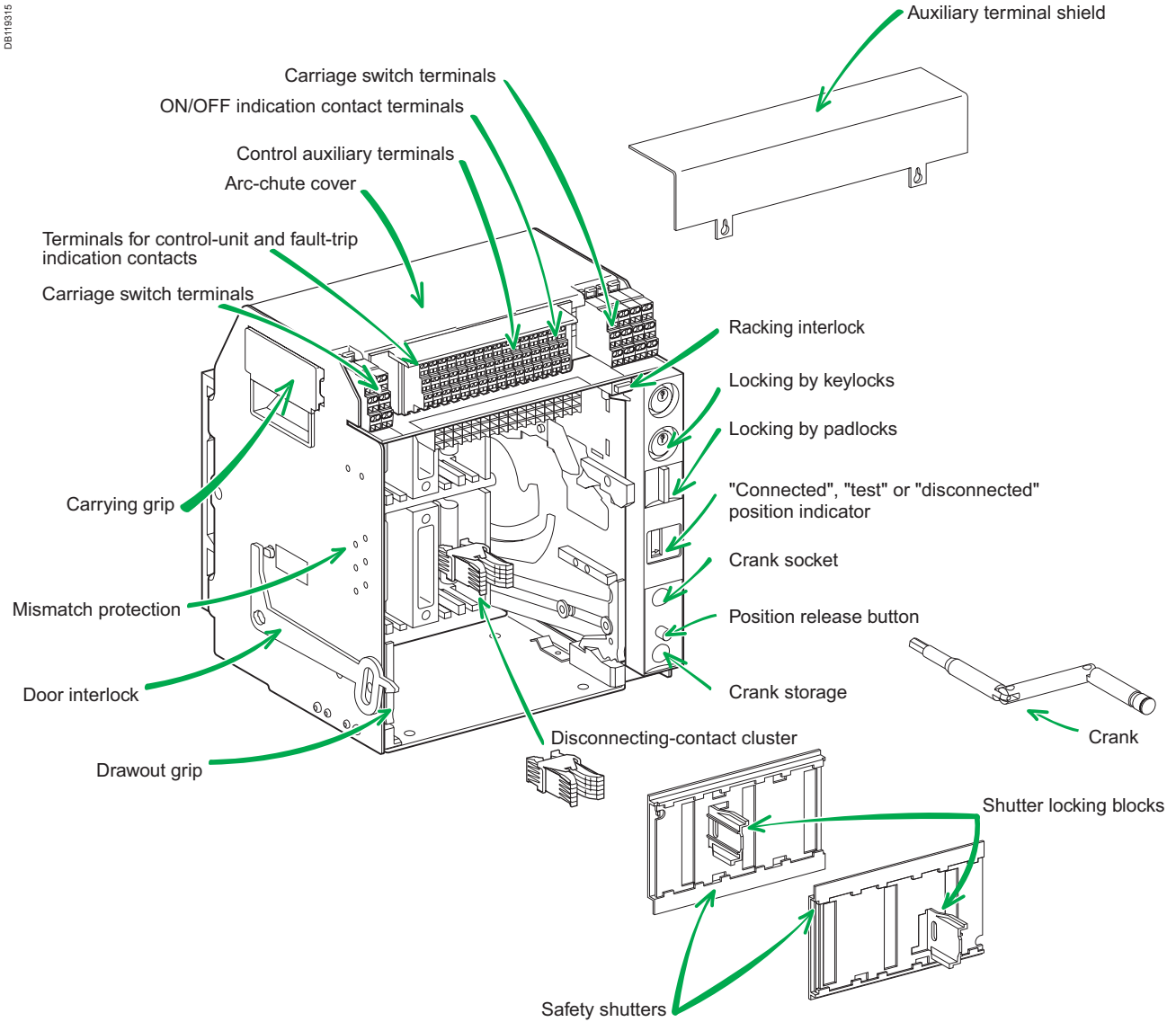

DB118315

## Drawout circuit breaker / switch-disconnector (moving part)

DB119216

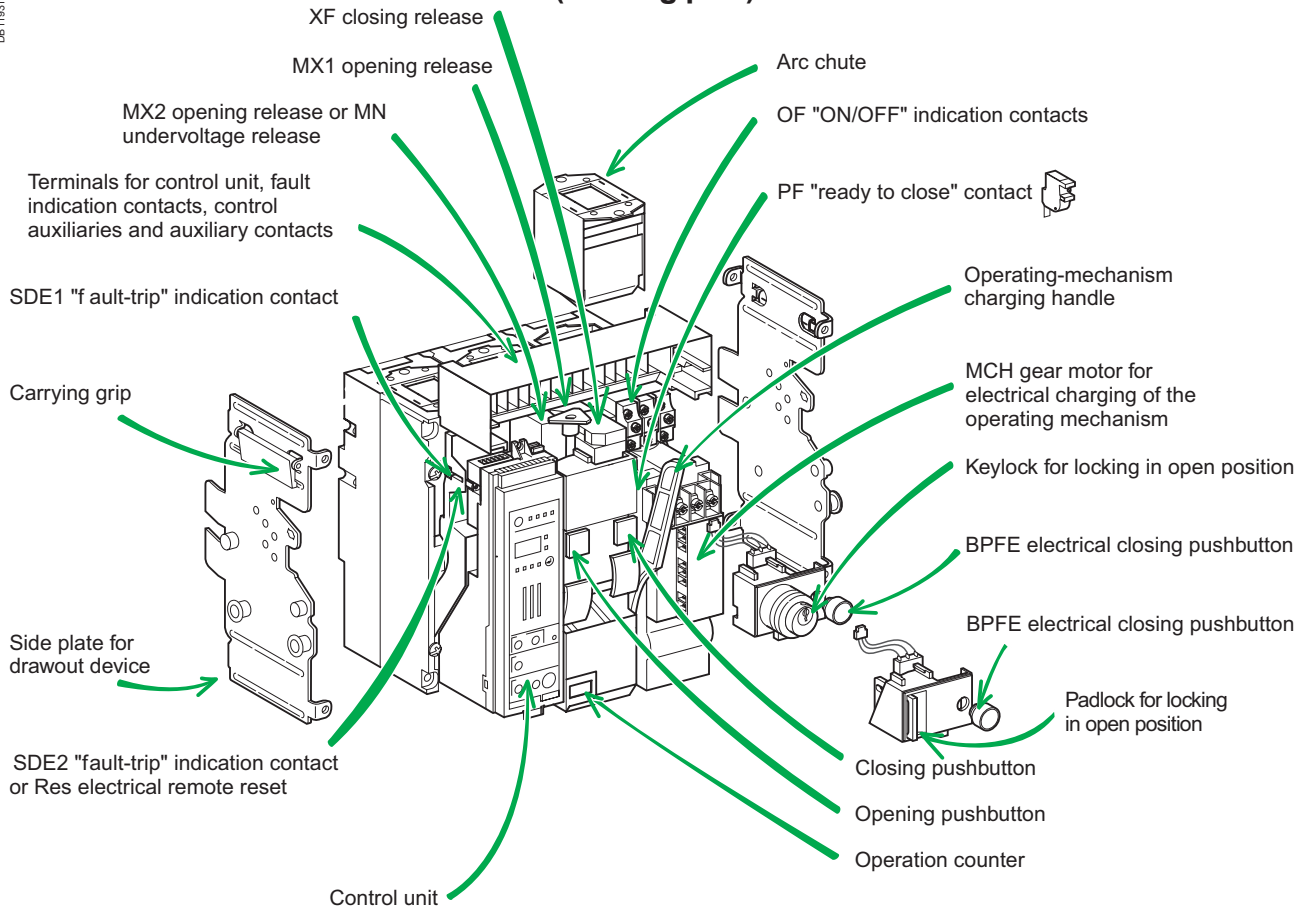



## Fixed circuit breaker / switch-disconnector

DE119317

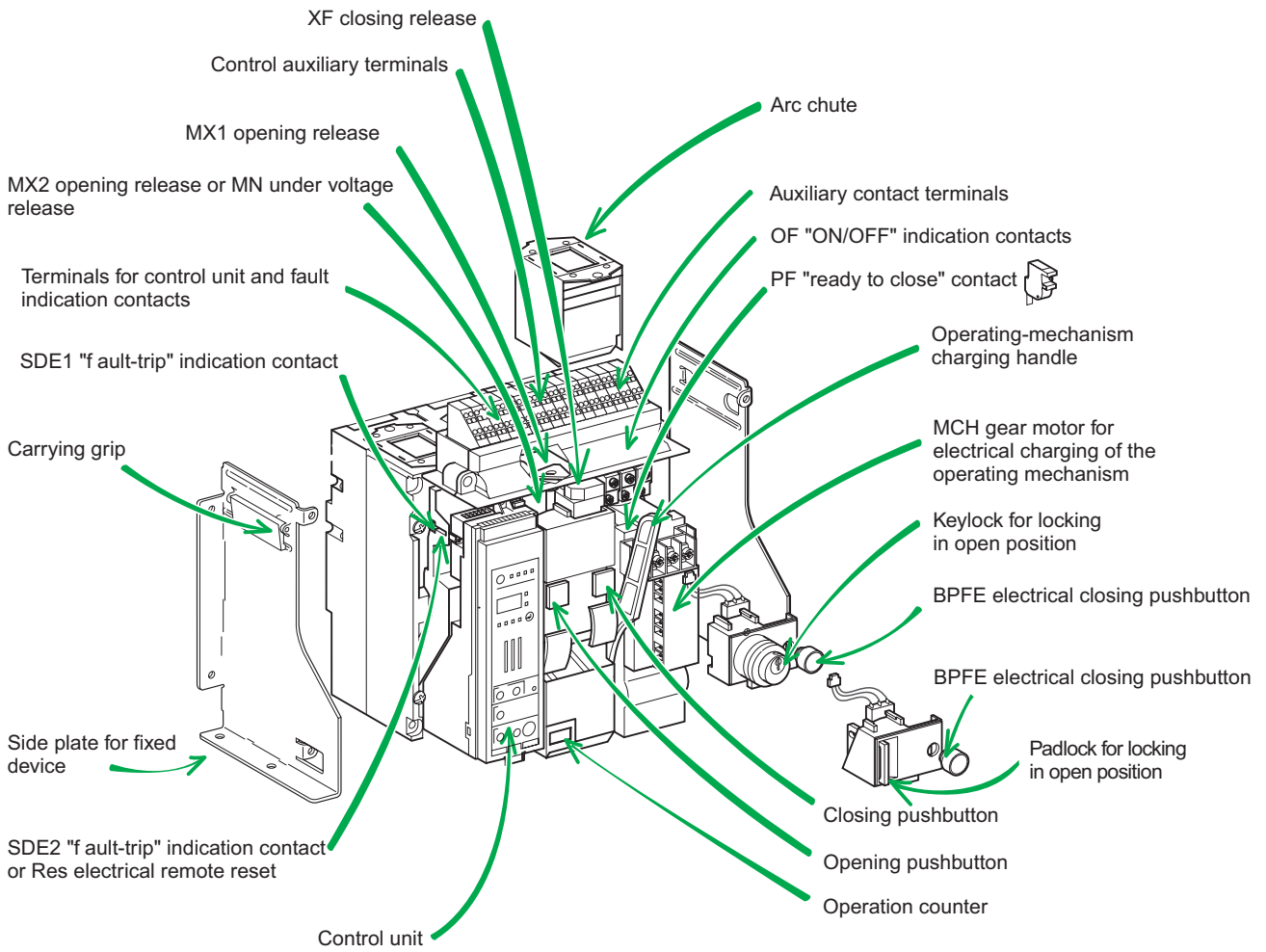

## Front

DE119318

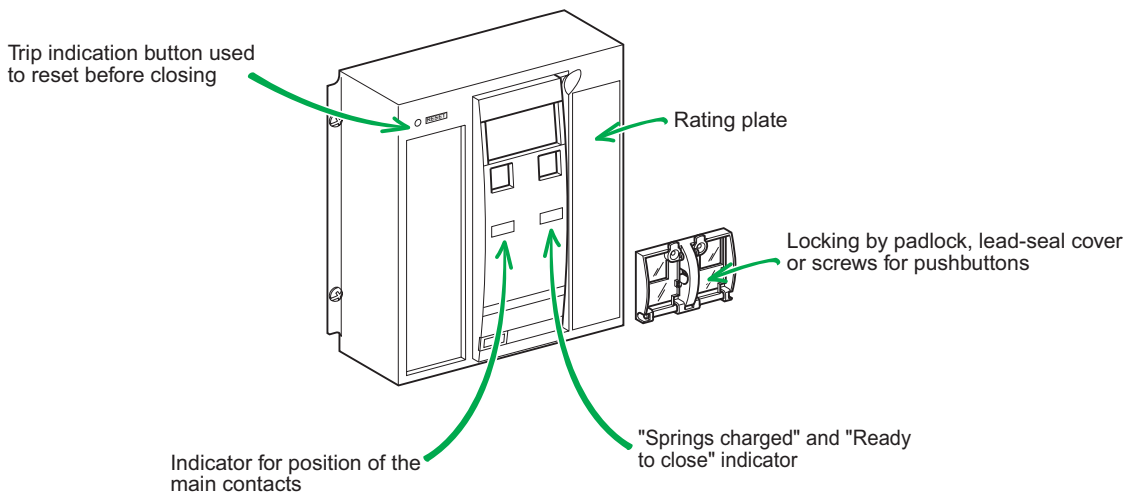

# Understanding the controls and indications

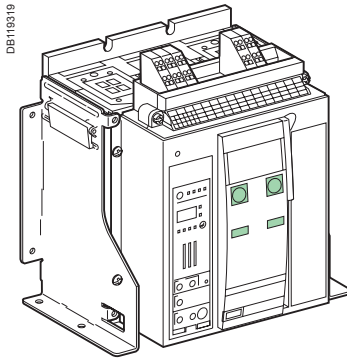

Circuit breaker open and discharged

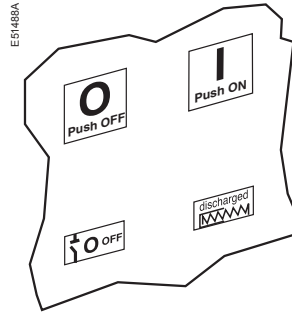

Circuit breaker closed and discharged

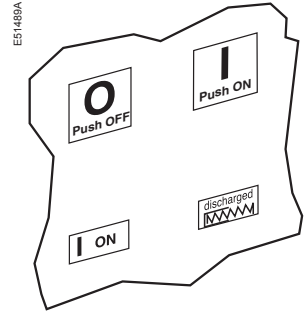

Circuit breaker open, charged and not "ready to close"

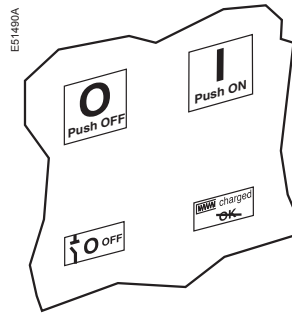

Circuit breaker closed and charged

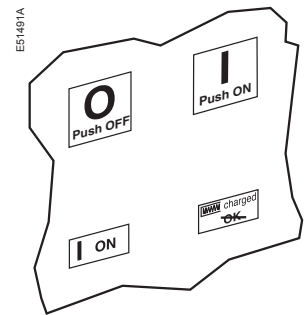

Circuit breaker open, charged and "ready to close"

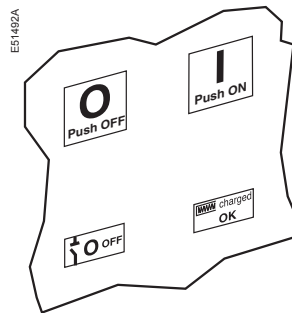

The charge status is indicated as follows.

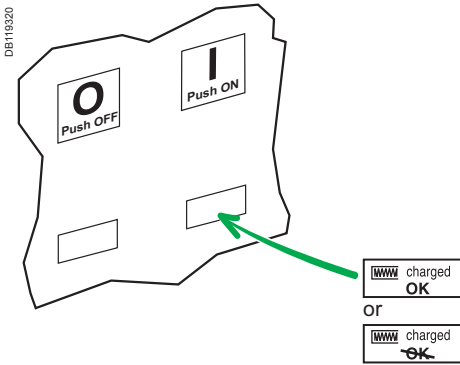

The springs in the circuit breaker operating mechanism must be charged to store the energy required to close the main contacts. The springs may be charged manually using the charging handle or automatically by the optional MCH gear motor.

**Manual charging.**  
Pull the handle down six times until you hear a "click".

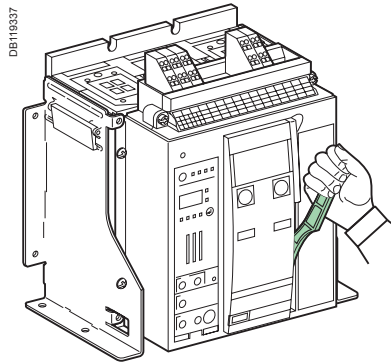

**Automatic charging.**  
If the MCH gear motor is installed, the spring is automatically recharged after each closing.

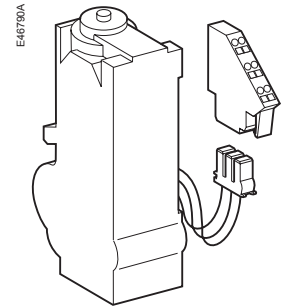

Device "ready to close"



Device not "ready to close"



## Closing conditions

Closing (i.e. turning the circuit ON) is possible only if the circuit breaker is "ready to close".

The prerequisites are the following:

- device open (OFF)
- springs charged
- no opening order present.

The circuit breaker will not close unless it is "ready to close" when the order is given. An opening order always takes priority over a closing order.

## Closing the circuit breaker

### Locally (mechanical)

Press the mechanical ON pushbutton.

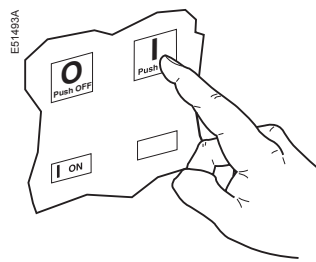
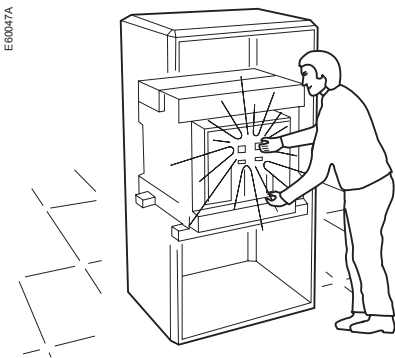

### Locally (electrical)

*BPFE*

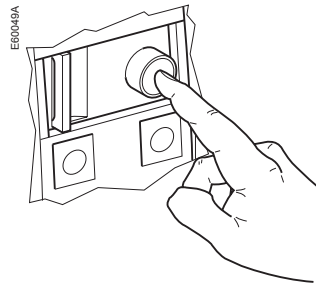

*XF*

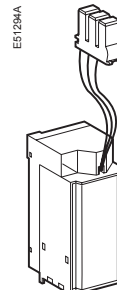

Press the electrical closing pushbutton. By adding an XF closing release, the circuit breaker can be closed locally. Electrical closing via the BPFE pushbutton takes into account all the safety functions that are part of the control/monitoring system of the installation. The BPFE connects to the closing release (XF com) in place of the COM module. The COM module is incompatible with this option.

### Remotely

*XF*

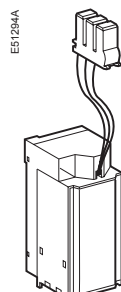

By adding an XF closing release, the circuit breaker can be closed locally. When connected to a remote control panel, the XF closing release can close the circuit breaker remotely.

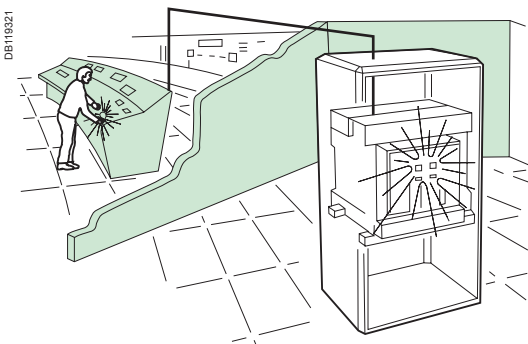

## Anti-pumping function

The purpose of the mechanical anti-pumping function is to ensure that a circuit breaker receiving simultaneous opening and closing orders does not open and close indefinitely.

If there is a continuous closing order, after opening the circuit breaker remains open until the closing order is discontinued. A new closing order is required to close the circuit breaker. A new order is not required if the closing release is wired in series with the PF "ready to close" contact.

**Locally**  
Press the OFF pushbutton.

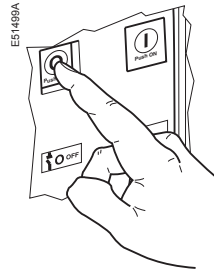
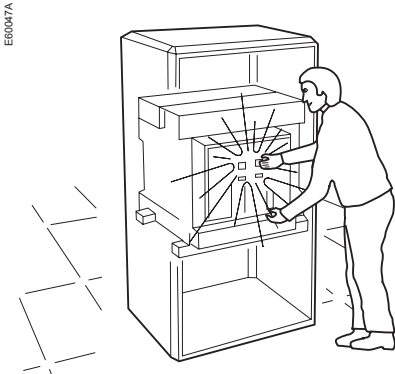

**Remotely**  
Use one of the following solutions:

- one or two MX opening releases (MX1 and MX2)
- one MN undervoltage release
- one MN undervoltage release with a delay unit.

When connected to a remote control panel, these releases can be used to open the circuit breaker remotely.

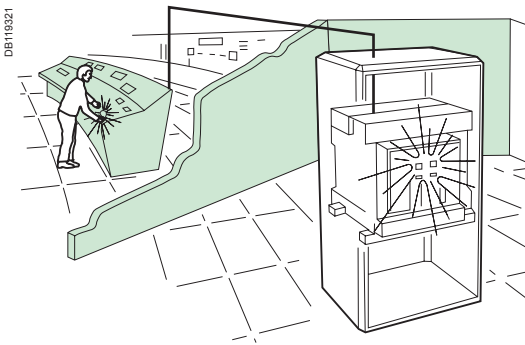

MX1, MX2, MN

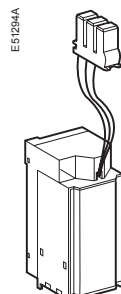

MN delay unit

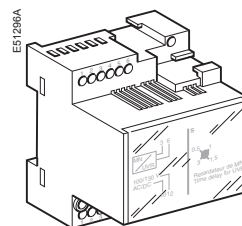

The circuit breaker signals a fault trip by:

- a mechanical indicator on the front
- one or two SDE "fault-trip" indication contacts (SDE2 is optional).

### Locally

If the circuit breaker is not equipped with the automatic reset option, reset it manually.

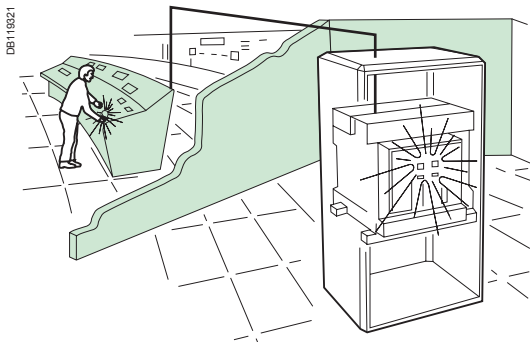
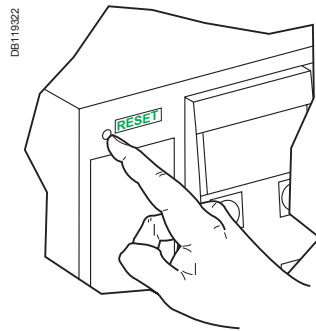
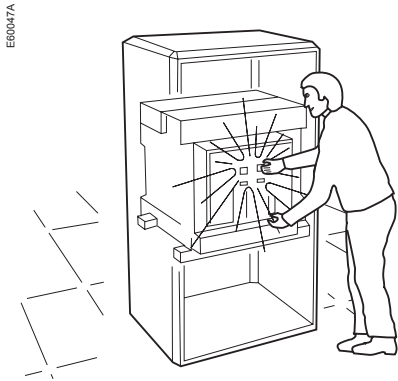

### Remotely

Use the Res electrical remote reset option (not compatible with an SDE2).

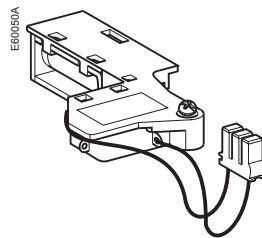

# Locking the controls

Disabling circuit-breaker local closing and opening

## Pushbutton locking using a padlock

(shackle diameter 5 to 8 mm), a lead seal or screws.

Padlock.

Lead seal.

Screws.

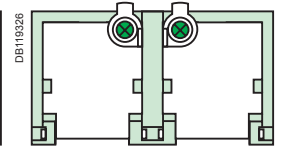
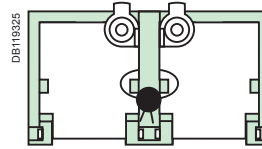
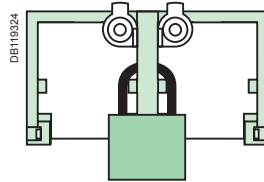
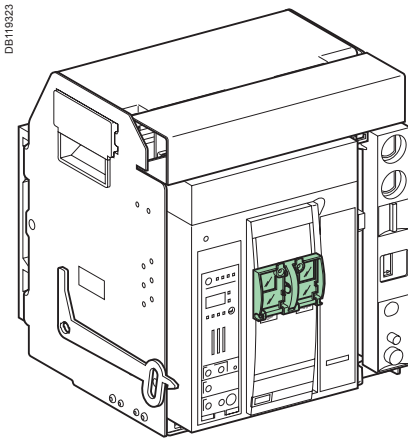

### Locking

Close the covers.

Insert the padlock shackle, lead seal or screws.

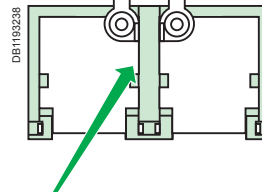
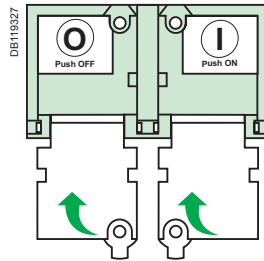

### Unlocking

Remove the padlock, lead seal or screws.

Lift the covers and swing them down.

The pushbuttons are no longer locked.

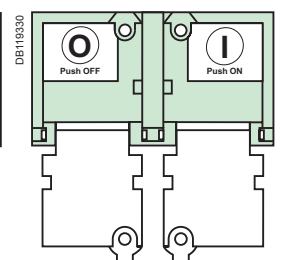
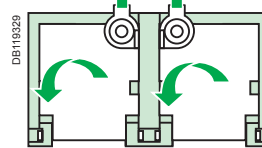
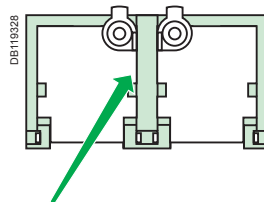

# Locking the controls

## Disabling local and remote closing

### Combination of locking systems

To disable local and remote circuit-breaker closing, use as needed 1 to 3 padlocks or a keylock.

### Install one to three padlocks (maximum shackle diameter 5 to 8 mm)

#### Locking

Open the circuit breaker.

Pull out the tab.

Insert the padlock shackle.

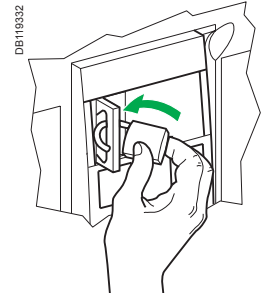
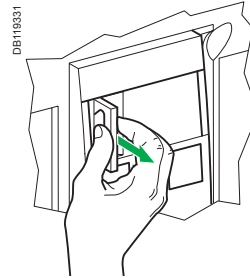
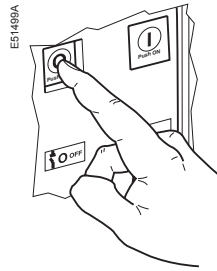

#### Check

The closing control is inoperative.

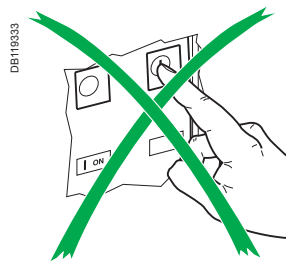

#### Unlocking

Remove the padlock.

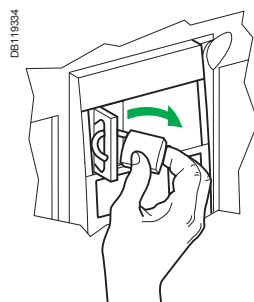



# Locking the controls

## Disabling local and remote closing

### Locking the controls with a keylock

#### Locking

Open the circuit breaker.

Turn the key.

Remove the key.

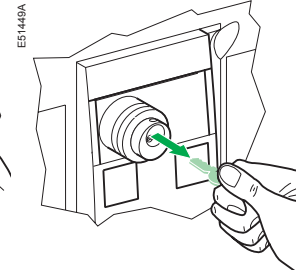
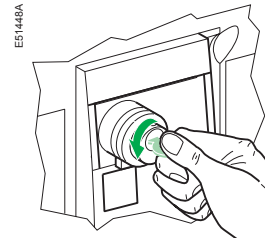
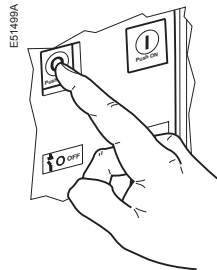

#### Check

The closing control is inoperative.

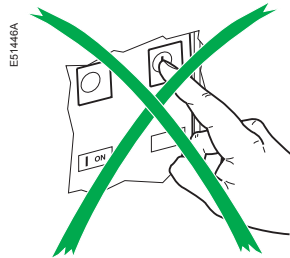

#### Unlocking

Insert the key.

Turn the key.

The key cannot be removed.

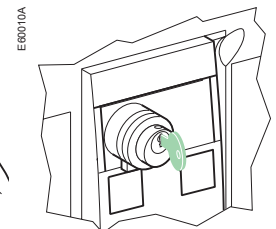
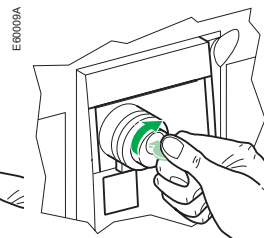
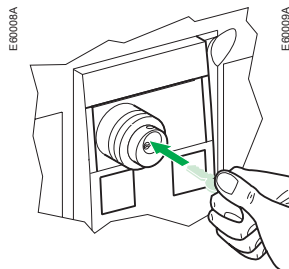

### Four types of keylocks can be installed

**RONIS**

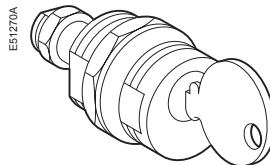

**PROFALUX**

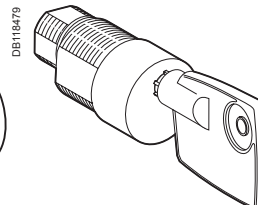

**CASTELL**

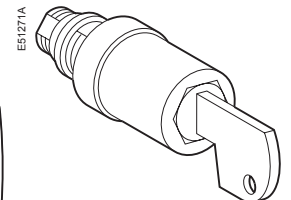

**KIRK**

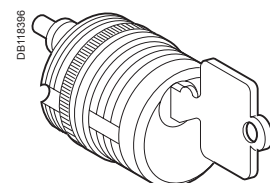

**Note :**

Castell and Kirk keylocks are not provided by Schneider Electric, only the adaptation kit is available.

# Identifying the circuit breaker positions

The indicator on the front signals the position of the circuit breaker in the chassis.

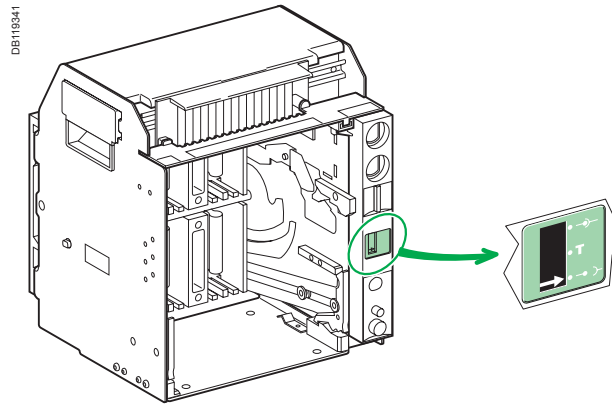

■ "connected" position

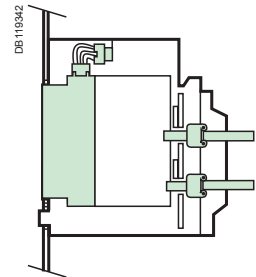
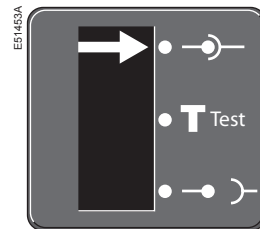

■ "test" position

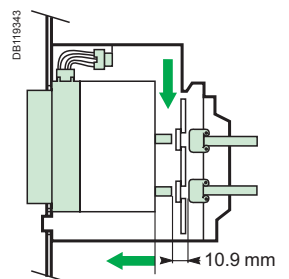
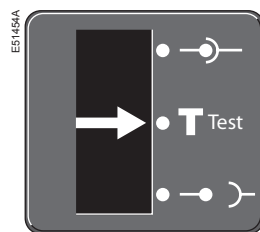

■ "disconnected" position

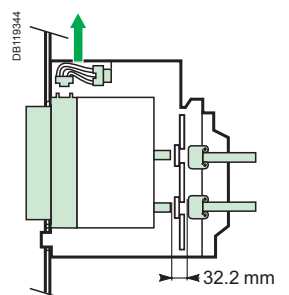
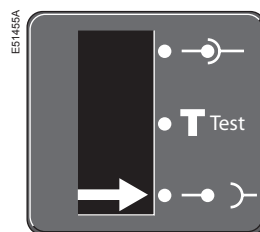

These operations require that all chassis-locking functions be disabled (see page 22).

## Prerequisites

To connect and disconnect Masterpact, the crank must be used. The locking systems, padlocks and the racking interlock all inhibit use of the crank.

## Withdrawing the circuit breaker from the "connected" to "test" position, then to "disconnected" position

The circuit breaker is in "connected" position. Push the pop-up button before starting to turn the crank.

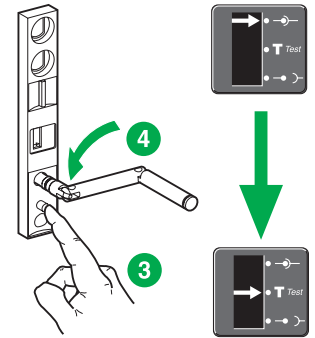
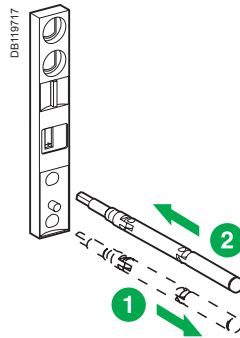

The circuit breaker is in "test" position.

The circuit breaker is in "test" position. Remove the crank or continue to "disconnected" position. Push the pop-up button before continuing to turn the crank.

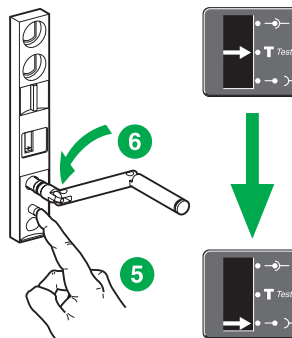

The circuit breaker is in "disconnected" position.

**STOP**

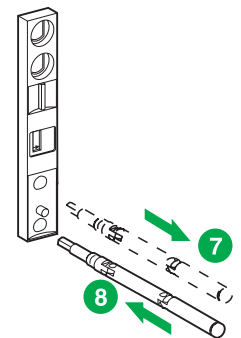

For complete information on Masterpact handling and mounting, see the installation manual(s).

Before mounting the circuit breaker, make sure it matches the chassis in terms of rated current and performance level.

## Removing the rails

Press the release tabs and pull the rails out.

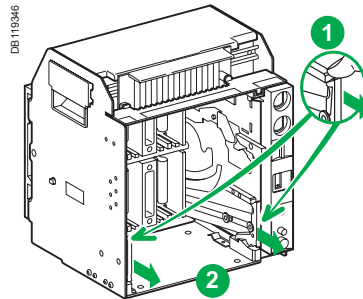

Press the release tabs to push the rails in.

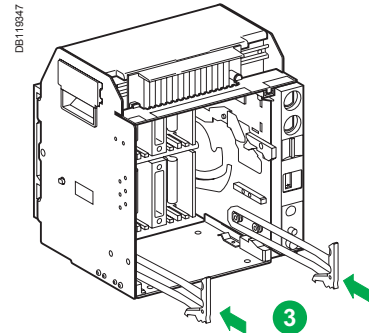

## Inserting Masterpact

Position the circuit breaker on the rails. Check that it rests on all four supports.

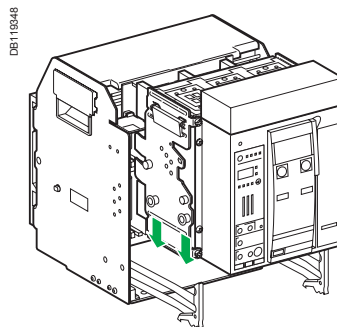

Open the circuit breaker (in any case, it opens automatically during connection).

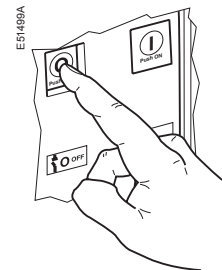

If you cannot insert the circuit breaker in the chassis, check that the mismatch protection on the chassis corresponds to that on the circuit breaker.

Push the circuit breaker into the chassis, taking care not to push on the control unit.

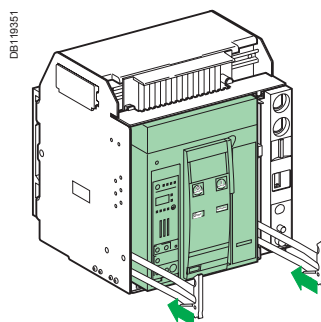
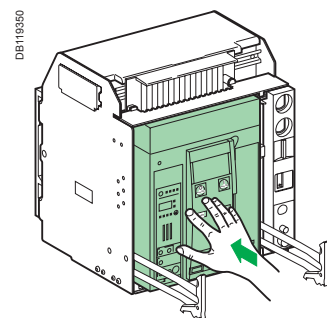
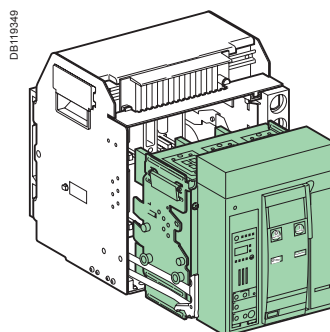

# Racking

## Racking the circuit breaker from the "disconnected" to "test" position, then to "connected" position

The device is in "disconnected" position. Push the pop-up button before continuing to turn the crank.

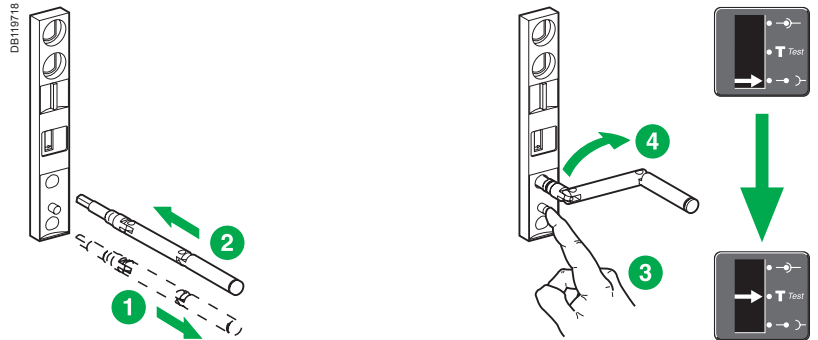

The device is in "test" position. Push the pop-up button before continuing to turn the crank.

The device is in "test" position. Remove the crank or continue to "connected" position.

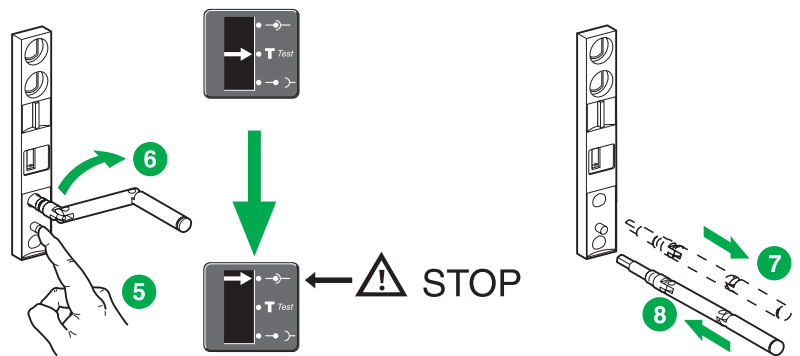

The device is in "connected" position.

# Matching a Masterpact circuit breaker with its chassis





To set up a mismatch-prevention combination for the circuit breaker and the chassis, see the mismatch-prevention installation manual.

The mismatch protection ensures that a circuit breaker is installed only in a chassis with compatible characteristics.

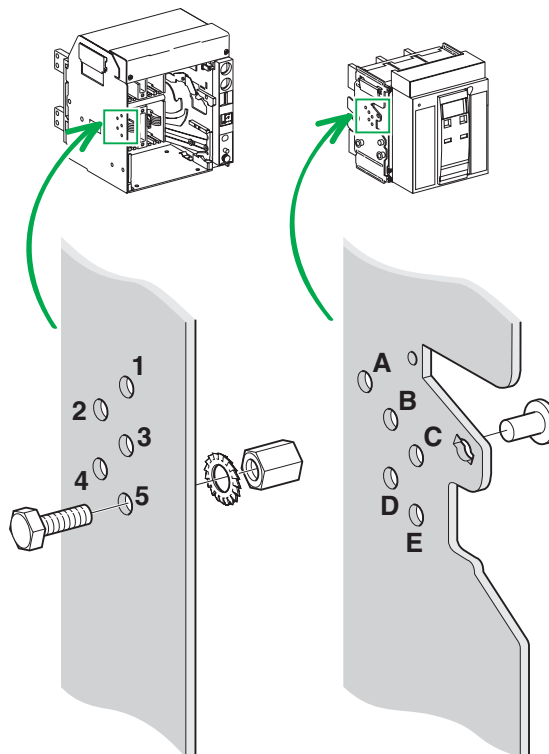
The possible combinations are listed below.

DB110353



			
<b>ABC</b>	<b>45</b>	<b>BCD</b>	<b>15</b>
<b>ABD</b>	<b>35</b>	<b>BCE</b>	<b>14</b>
<b>ABE</b>	<b>34</b>	<b>BC</b>	<b>145</b>
<b>AB</b>	<b>345</b>	<b>BDE</b>	<b>13</b>
<b>ACD</b>	<b>25</b>	<b>BD</b>	<b>135</b>
<b>ACE</b>	<b>24</b>	<b>BE</b>	<b>134</b>
<b>AC</b>	<b>245</b>	<b>CDE</b>	<b>12</b>
<b>ADE</b>	<b>23</b>	<b>CD</b>	<b>125</b>
<b>AD</b>	<b>235</b>	<b>CE</b>	<b>124</b>
<b>AE</b>	<b>234</b>	<b>DE</b>	<b>123</b>

# Locking the switchboard door

The locking option is installed on the left or right-hand side of the chassis.

- When the circuit breaker is in "connected" or "test" position, the latch is lowered and the door is locked
- When the circuit breaker is in "disconnected" position, the latch is raised and the door is unlocked.

DB110354

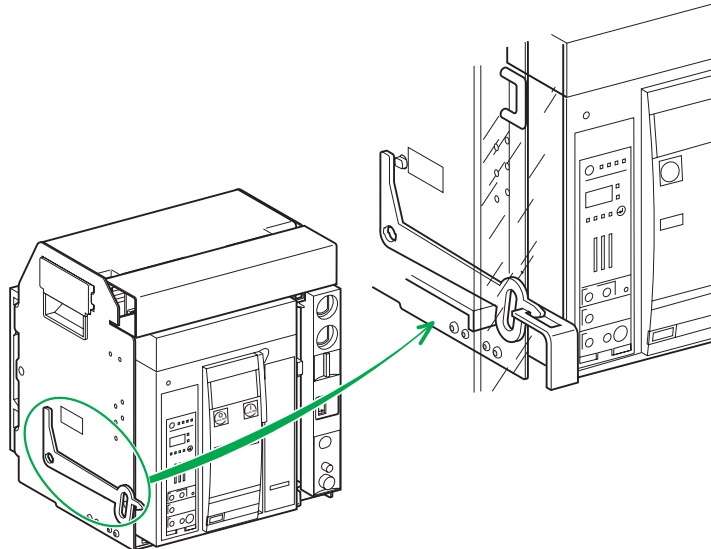

## Disabling door opening

Close the door.

Put the Masterpact in  
"test" or "connected"  
position.

The door is locked.

E51465A

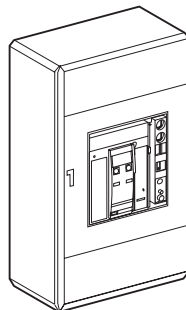

DB110355

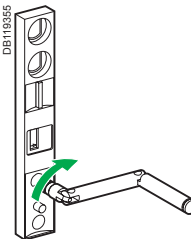

DB110356

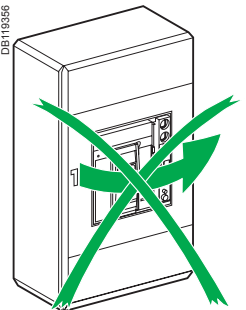

## Enabling door opening

Put the Masterpact in  
"disconnected" position.

The door is unlocked.

DB110357

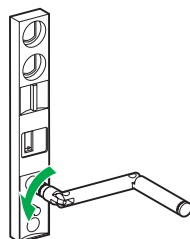

E51460A

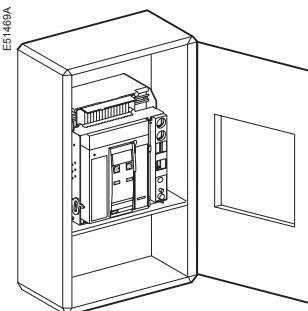

# Locking the circuit breaker in position

Padlocks and keylocks may be used together.

If specified when ordering the chassis, this locking function may be adapted to operate in all positions ("connected", "test" and "disconnected"), instead of in "disconnected" position only.

## Combination of locking systems

With the circuit breaker in the "disconnected" position, for forbidding its connection in the chassis, use as needed:

- one to three padlocks
- one or two keylocks
- a combination of the two locking systems.

## Disabling connection when the circuit breaker is in "disconnected" position, using one to three padlocks (maximum shackle diameter 5 to 8 mm)

### Locking

Circuit breaker in "disconnected" position.

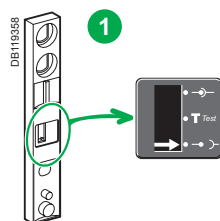

Insert the shackle (max. diameter 5 to 8 mm) of the padlock(s).

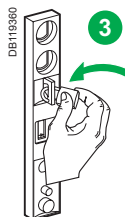

### Unlocking

Remove the padlock(s).

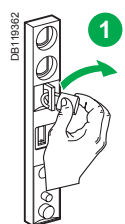

The crank can be inserted.

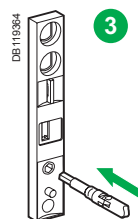

Pull out the tab.

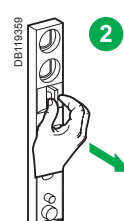

The crank cannot be inserted.

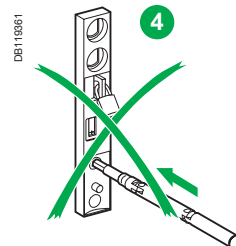

Release the tab.

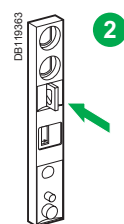



# Locking the circuit breaker in position

Padlocks and keylocks may be used together.

## Disabling connection when the circuit breaker is in "disconnected" position, using one or two keylocks.

### Locking

Circuit breaker in "disconnected" position.

Turn the key(s).

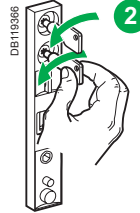
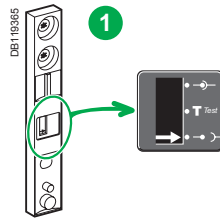

Remove the key(s).

The crank cannot be inserted.

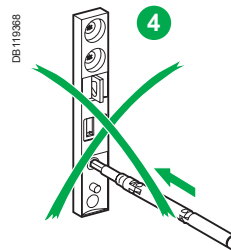

### Unlocking

Insert the key(s).

Turn the key(s).

The crank can be inserted.

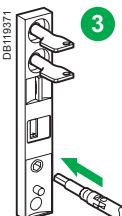
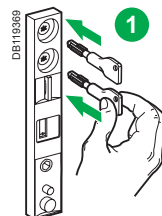

## Four types of keylocks are available

**RONIS**

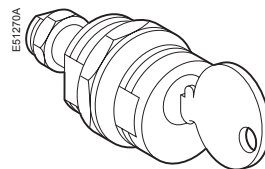

**PROFALUX**

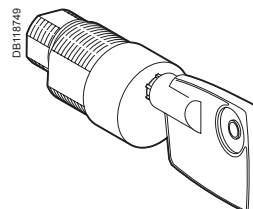

**CASTELL**

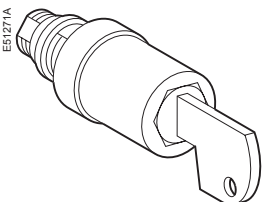

**KIRK**

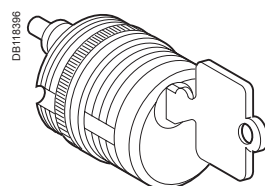

**Note :**

Castell and Kirk keylocks are not provided by Schneider Electric, only the adaptation kit is available.

# Locking the circuit breaker in position

## Locking the circuit breaker when the door is open

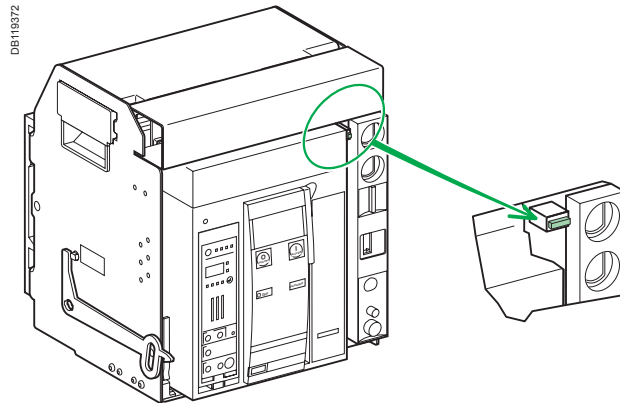

When the door is open, the crank cannot be inserted.

When the door is closed, the crank can be inserted.

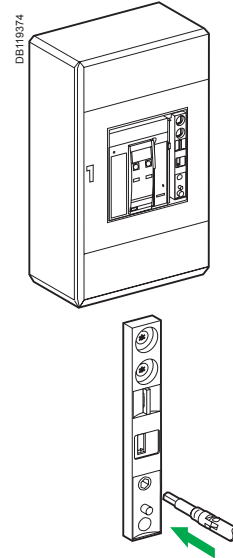
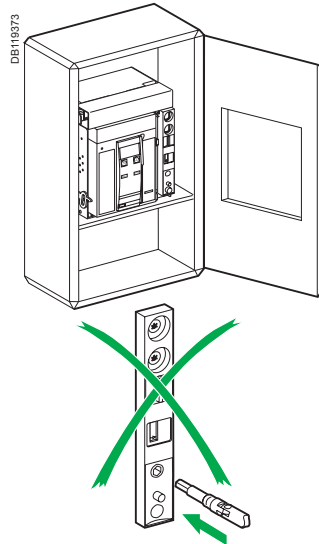

# Locking the safety shutters

## Padlocking inside the chassis

### Four locking possibilities: using one or two padlocks (maximum shackle diameter 5 to 8 mm) for each shutter

Top and bottom shutters not locked.

DB110375

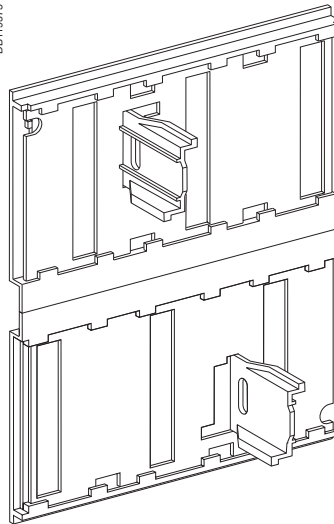

Top shutter not locked.  
Bottom shutter locked.

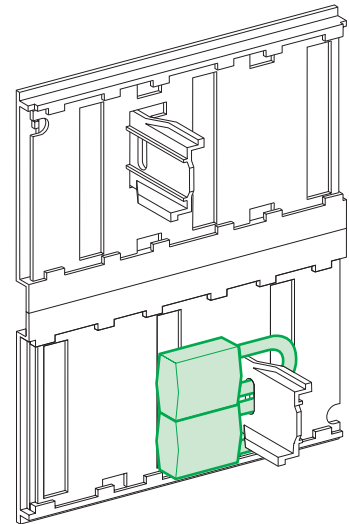

Top shutter locked.  
Bottom shutter not locked.

DB110376

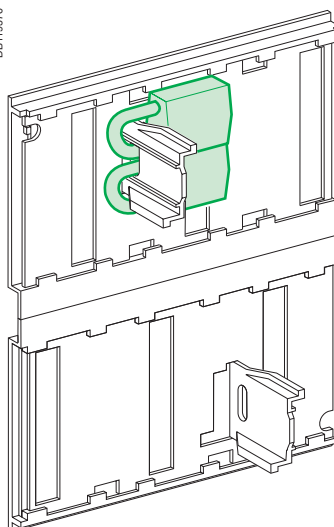

Top and bottom shutters locked.

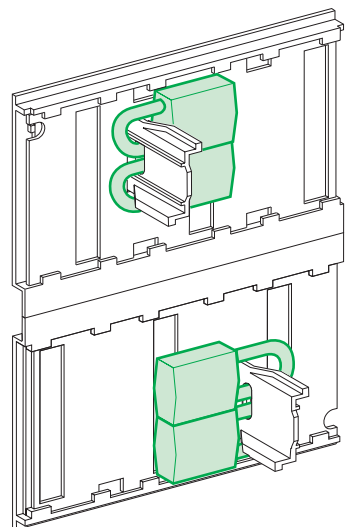

# Identification of the connection terminals

## Layout of terminal blocks

DB119377

CD2	CD1
824	814
822	812
821	811

Com	UC1	UC2	UC3	M2C/UC4	SDE2/Res	SDE1	MN/MX2	MX1	XF	PF	MCH
E5 E6	Z5 M1	M2 M3	F2	484/V3	184/K2	84	D2/C12	C2	A2	254	B2
E3 E4	Z3 Z4	T3 T4	VN	474/V2	182	82	C13	C3	A3	252	B3
E1 E2	Z1 Z2	T1 T2	F1	471/V1	181/K1	81	D1/C11	C1	A1	251	B1

OF4	OF3	OF2	OF1
44	34	24	14
42	32	22	12
41	31	21	11

CE3	CE2	CE1	CT1
334	324	314	914
332	322	312	912
331	321	311	911

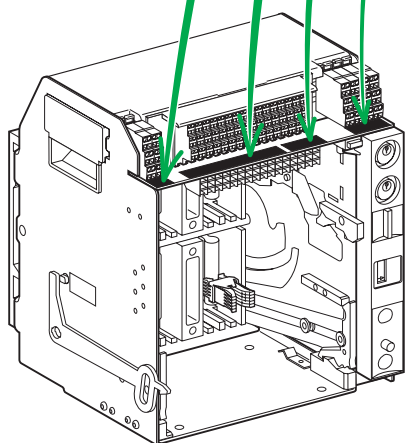

Com	UC1	UC2	UC3	M2C/UC4	SDE2/Res	SDE1	MN/MX2	MX1	XF	PF	MCH
E5 E6	Z5 M1	M2 M3	F2	484/V3	184/K2	84	D2/C12	C2	A2	254	B2
E3 E4	Z3 Z4	T3 T4	VN	474/V2	182	82	C13	C3	A3	252	B3
E1 E2	Z1 Z2	T1 T2	F1	471/V1	181/K1	81	D1/C11	C1	A1	251	B1

OF4	OF3	OF2	OF1
44	34	24	14
42	32	22	12
41	31	21	11

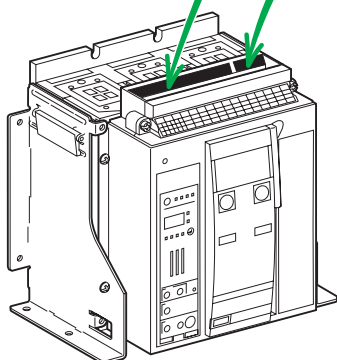

The ON/OFF indication contacts signal the status of the device main contacts.

## Circuit breaker

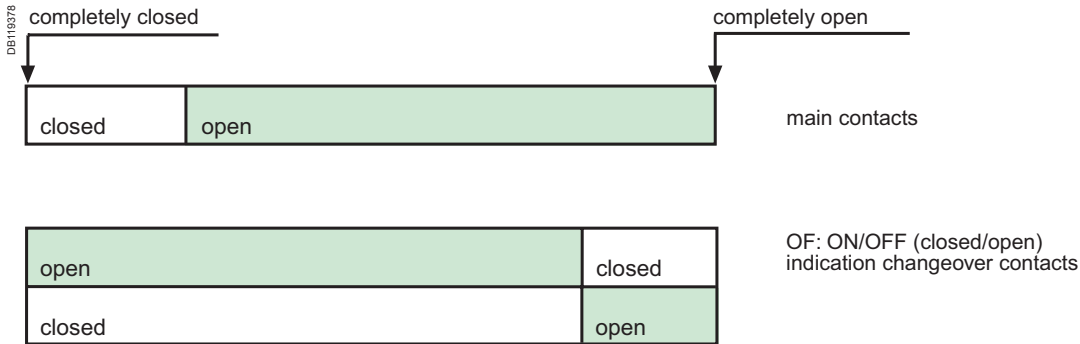

The carriage switches indicate the "connected", "test" and "disconnected" positions.

## Chassis

For information on the separation distance of the main circuits in the "test" and "disconnected" positions, see page 16.

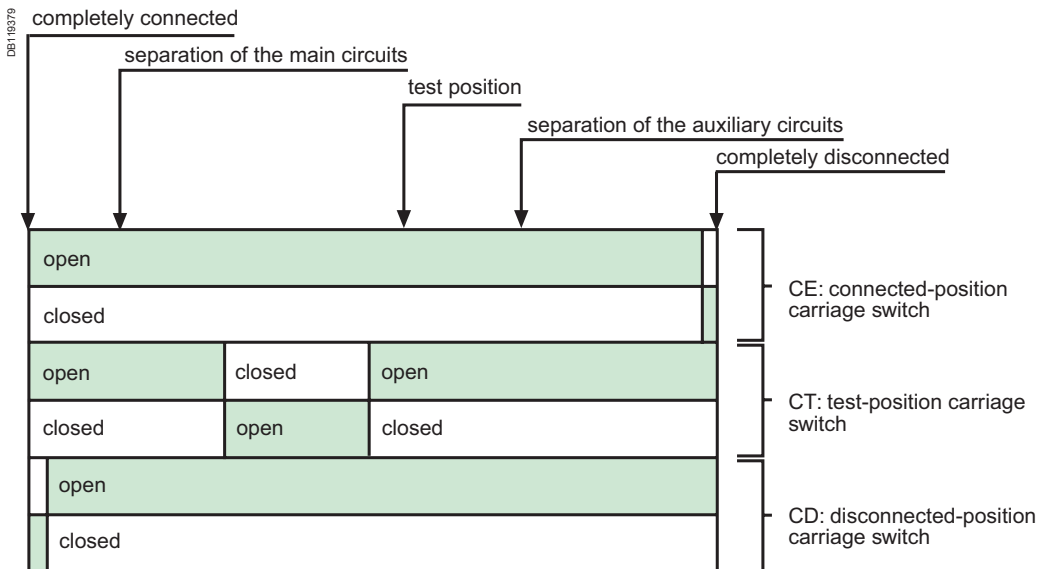

The diagram is shown with circuits de-energised, all devices open, connected and charged and relays in normal position.

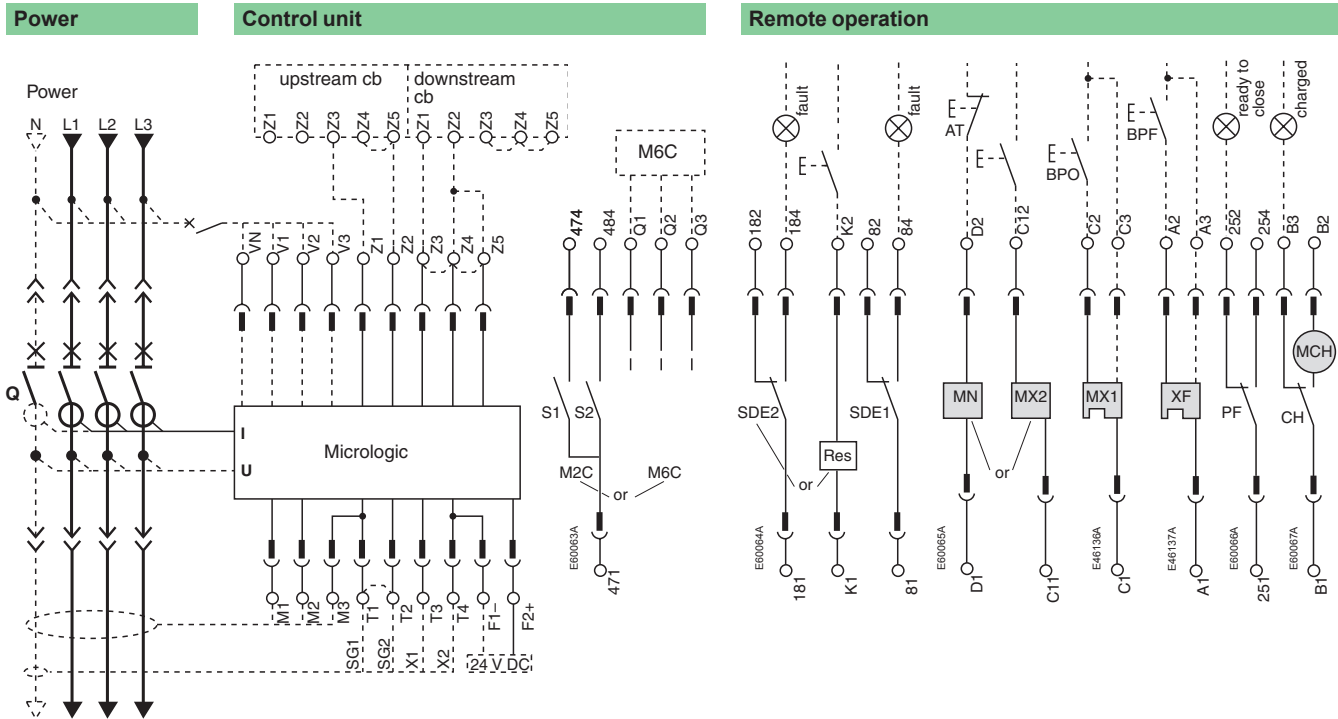

Com		UC1		UC2		UC3		UC4 / M2C / M6C	
○	○	○	○	○	○	○	○	○	○
E5	E6	Z5	M1	M2	M3	F2+	V3 / 484 / Q3	○	○
○	○	○	○	○	○	○	○	○	○
E3	E4	Z3	Z4	T3	T4	VN	V2 / 474 / Q2	○	○
○	○	○	○	○	○	○	○	○	○
E1	E2	Z1	Z2	T1	T2	F1-	V1 / 471 / Q1	○	○

SDE2 / Res		SDE1		MN / MX2		MX1		XF		PF		MCH	
○	○	○	○	○	○	○	○	○	○	○	○	○	○
184 /	K2	84		D2 /	C12	C2	A2	254	B2				
○	○	○	○	○	○	○	○	○	○	○	○	○	○
182		82		○	○	C3	A3	252	B3				
○	○	○	○	○	○	○	○	○	○	○	○	○	○
181 /	K1	81		D1 /	C11	C1	A1	251	B1				

A	E	P	H	Control unit	Remote operation
■	■	■	■	<b>Com:</b> E1-E6 communication	<b>SDE2:</b> Fault-trip indication contact <b>or</b> <b>Res:</b> Remote reset
■	■	■	■	<b>UC1:</b> Z1-Z5 zone selective interlocking; Z1 = ZSI OUT SOURCE Z2 = ZSI OUT; Z3 = ZSI IN SOURCE Z4 = ZSI IN ST (short time) Z5 = ZSI IN GF (earth fault) M1 = Vigi module input (Micrologic 7)	<b>SDE1:</b> Fault-trip indication contact (supplied as standard)
■	■	■	■	<b>UC2:</b> T1, T2, T3, T4 = external neutral; M2, M3 = Vigi module input (Micrologic 7)	<b>MN:</b> Undervoltage release <b>or</b> <b>MX2:</b> Shunt release
■	■	■	■	<b>UC3:</b> F2+, F1- external 24 V DC power supply VN external voltage connector	<b>MX1:</b> Shunt release (standard or communicating)
■	■	■	■	<b>UC4:</b> V1, V2, V3 optional external voltage connector <b>or</b> <b>M2C:</b> 2 programmable contacts (internal relay); ext. 24 V DC power supply required <b>or</b> <b>M6C:</b> 6 programmable contacts (external relay); ext. 24 V DC power supply required.	<b>XF:</b> Closing release (standard or communicating) <b>PF:</b> "Ready to close" contact <b>MCH:</b> Gear motor (*)
					<b>Note:</b> When communicating MX or XF releases are used, the third wire (C3, A3) must be connected even if the communications module is not installed.

A: Digital ammeter, E: A + energy  
P: E+ power meter + programmable protection, H: P + harmonics

### Indication contacts

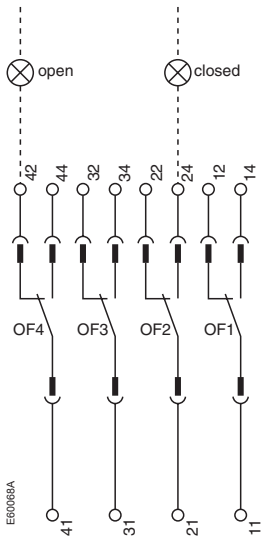

### Chassis contacts

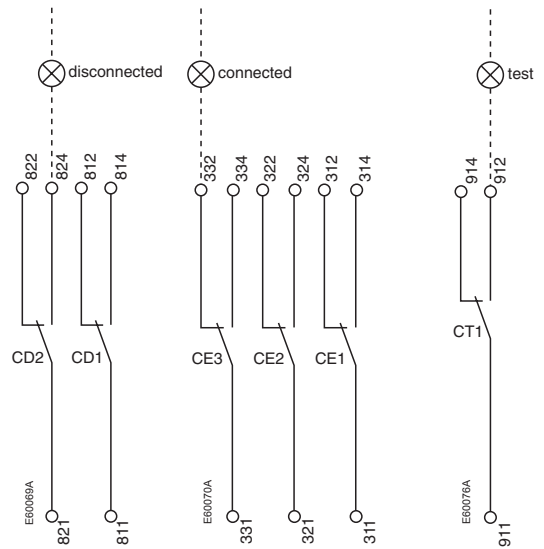

### Indication contacts

OF4	OF3	OF2	OF1

### Contacts chassis

CD2	CD1	CE3	CE2	CE1	CT1

### Indication contacts

OF4 / OF3 / OF2 / OF1: ON/OFF indication contacts

### Chassis contacts

CD2-CD1: Disconnected-position  
 CE3-CE2-CE1: Connected-position  
 CT1: Test-position contacts

(\*) 440/480 V AC gear motor for charging  
 (380 V motor + additional resistor)

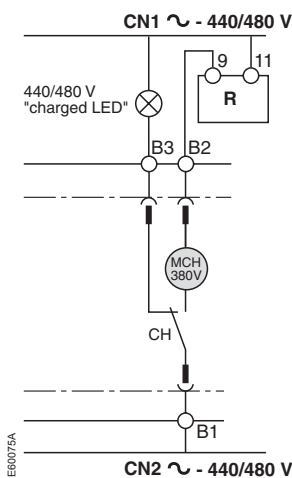

Key:

- Drawout device only
- SDE1, OF1, OF2, OF3, OF4 supplied as standard
- Interconnected connections (only one wire per connection point)

For the spare parts list, see the Masterpact NT/ NW catalogue. For more in-depth information, see the control-unit user manual.

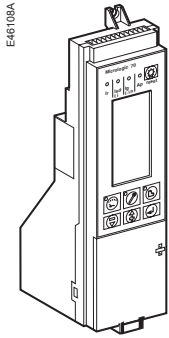

## Micrologic control units

- All Masterpact circuit breakers are equipped with a Micrologic control unit. Control units are designed to protect power circuits and loads. Alarms may be programmed for remote indications.
  - Micrologic 2.0 A
  - Micrologic 5.0 A
  - Micrologic 6.0 A
  - Micrologic 7.0 A
  - Micrologic 2.0 E
  - Micrologic 5.0 E
  - Micrologic 6.0 E
  - Micrologic 5.0 P
  - Micrologic 6.0 P
  - Micrologic 7.0 P
  - Micrologic 5.0 H
  - Micrologic 6.0 H
  - Micrologic 7.0 H
- Depending on the model, control units offer in addition:
  - fault indications
  - measurement of electrical parameters (current, voltage, power, etc.)
  - harmonic analysis
  - communication.

## Long-time rating plugs

- Standard accessory, one per control unit
  - standard 0.4 to 1 x I<sub>r</sub> setting
  - low 0.4 to 0.8 x I<sub>r</sub> setting
  - high 0.8 to 1 x I<sub>r</sub> setting
  - off (no long-time protection).
- The plugs determine the setting range for the long-time protection.

## M2C and M6C programmable contacts

- Optional accessory, used with Micrologic P and H control units
  - M2C: 2 programmable contacts
  - M6C: 6 programmable contacts
- Contacts can be programmed using the keypad on the control unit or via the COM option
  - They indicate:
    - the type of fault
    - instantaneous or delayed threshold overruns.
- M2C: 2 contacts (5 A - 240 V)
- M6C: 6 contacts (5 A - 240 V).
  - Permissible load on each of the M6C relay outputs at cos φ = 0.7
    - 240 V AC: 5 A
    - 380 V AC: 3 A
    - 24 V DC: 1.8 A
    - 48 V DC: 1.5 A
    - 125 V DC: 0.4 A
    - 250 V DC: 0.15 A
  - M2C: 24 V DC ± 5 % power from control unit
  - M6C: 24 V DC ± 5 % external supply
  - Maximum consumption: 100 mA.



## ON/OFF indication contacts (OF)

- Standard accessory, 4 OF per device

- OF contacts indicate the position of the main contacts
- They switch when the minimum isolation distance between the main contacts is reached.

- 4 changeover contacts
- Breaking capacity at  $\cos \varphi = 0.3$  (AC12 / DC12 as per IEC 60947-5-1)
- standard, minimum current 10 mA / 24 V

V AC	240/380	6 A (rms)
	480	6 A (rms)
	690	6 A (rms)
V DC	24/48	2.5
	125	0.5
	250	0.3

- low level, minimum current 1 mA / 4 V

V AC	24/48	5 A (rms)
	240	5 A (rms)
	380	5 A (rms)
V DC	24/48	5 / 2.5 A
	125	0.5 A
	250	0.3 A

## "Fault-trip" indication contact (SDE1)

- Standard accessory on circuit breakers, one SDE1 contact per device
- Not available for switch-disconnector versions.

- The contact provides a remote indication of device tripping due to an electrical fault.

- Changeover contact
- Breaking capacity at  $\cos \varphi = 0.3$  (AC12 / DC12 as per IEC60947-5-1)
- standard, minimum current 10 mA / 24 V

V AC	240/380	5 A (rms)
	480	5 A (rms)
	690	3 A (rms)
V DC	24/48	3 A
	125	0.3 A
	250	0.15 A

- low level, minimum current 1 mA / 4 V

V AC	24/48	3 A (rms)
	240	3 A (rms)
	380	3 A (rms)
V DC	24/48	3 A
	125	0.3 A
	250	0.15 A

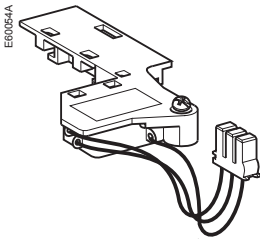

## Additional "fault-trip" indication contact (SDE2)

- Optional accessory for circuit breakers, one additional SDE2 contact per device
- Not available for switch-disconnector versions
- Not compatible with the Res option

- The contact remotely indicates device tripping due to an electrical fault.

- Changeover contact
- Breaking capacity at  $\cos \varphi = 0.3$  (AC12 / DC12 as per IEC 60947-5-1)
- standard, minimum current 10 mA / 24 V

V AC	240/380	5 A (rms)
	480	5 A (rms)
	690	3 A (rms)
V DC	24/48	3 A
	125	0.3 A
	250	0.15 A

- low level, minimum current 1 mA / 4 V

V AC	24/48	3 A (rms)
	240	3 A (rms)
	380	3 A (rms)
V DC	24/48	3 A
	125	0.3 A
	250	0.15 A

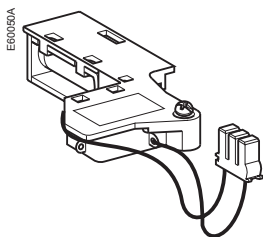

## Electrical reset after fault trip (Res)

- Optional accessory, one Res per device
- Not compatible with the SDE2 option
- Power supply:
  - 110/130 V AC
  - 220/240 V AC
- The Res option allows the remote resetting of the device following tripping due to an electrical fault.

## "Springs charged" limit switch contact (CH)

- Contact included with MCH gear motor, one CH contact per device.
- The contact indicates the "charged" status of the operating mechanism (springs charged).
- Changeover contact
- Breaking capacity 50/60 Hz for AC power (AC12 / DC12 as per IEC 60947-5-1):

V AC	240	10A(rms)
	380	6 A (rms)
	480	6 A (rms)
	690	3 A (rms)
V DC	24/48	3 A
	125	0.5 A
	250	0.25 A

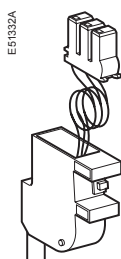

## "Ready to close" contact (PF)

- One optional PF contact per device
- The contact indicates that the device may be closed because all the following are valid:
  - circuit breaker is open
  - spring mechanism is charged
  - a maintained closing order is not present
  - a maintained opening order is not present.
- Changeover contact
- Breaking capacity at  $\cos \varphi = 0.3$  (AC12 / DC12 as per IEC 60947-5-1)
  - standard, minimum current 10 mA / 24 V

V AC	240/380	5 A (rms)
	480	5 A (rms)
	690	3 A (rms)
V DC	24/48	3 A
	125	0.3 A
	250	0.15 A

low level, minimum current 1 mA / 4 V

V AC	24/48	3 A (rms)
	240	3 A (rms)
	380	3 A (rms)
V DC	24/48	3 A
	125	0.3 A
	250	0.15 A

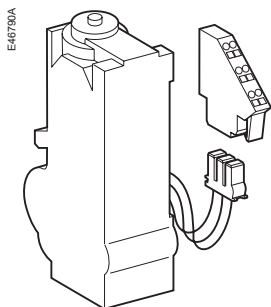

## Gear motor (MCH)

- Optional accessory, one MCH gear motor per device
- Power supply:
  - V AC 50/60 Hz:
    - 48/60 V AC
    - 100/130 V AC
    - 200/240 V AC
    - 277 V AC
    - 380/415 V AC
    - 400/440 V AC
    - 480 V AC
  - V DC:
    - 24/30 V DC
    - 48/60 V DC
    - 100/125 V DC
    - 200/250 V DC
- The gear motor automatically charges the spring mechanism.
- Operating threshold: 0.85 to 1.1 Un
- Consumption: 180 VA or W
- Inrush current: 2 to 3 In for 0.1 second
- Charging time: 3 seconds max.
- Operating rate: maximum 3 cycles per minute
- CH contact: see page 32.

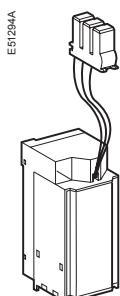

## Opening releases MX1 and MX2, closing release XF

- Optional accessory, 1 or 2 MX releases per device, 1 XF per device
- The function (MX or XF) is determined by where the coil is installed
- Power supply:
  - V AC 50/60 Hz:
    - 24 V AC
    - 48 V AC
    - 100/130 V AC
    - 200/250 V AC
    - 277 V AC
    - 380/480 V AC
  - V DC:
    - 12 V DC
    - 24/30 V DC
    - 48/60 V DC
    - 100/130 V DC
    - 200/250 V DC
- The MX release instantaneously opens the circuit breaker when energised
- The XF release instantaneously closes the circuit breaker when energised, if the device is "ready to close".
- Operating threshold:
  - XF: 0.85 to 1.1 Un
  - MX: 0.7 to 1.1 Un
- Consumption:
  - pick-up: 200 VA or W (80 ms)
  - hold: 4.5 VA or W
- Circuit-breaker response time at Un:
  - XF: 55 ms ± 10
  - MX: 50 ms ± 10.

# Auxiliaries for remote operation

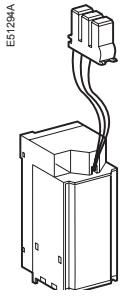

## Instantaneous undervoltage releases (MN)

- Optional accessory, 1 MN per device
- Not compatible with the MX2 opening release
- Power supply :
  - V AC 50/60 Hz:
    - 24 V AC
    - 48 V AC
    - 100 / 130 V AC
    - 200 / 250 V AC
    - 380 / 480 V AC
  - V DC:
    - 24 / 30 V DC
    - 48 / 60 V DC
    - 100 / 130 V DC
    - 200 / 250 V DC
- The MN release instantaneously opens the circuit breaker when its supply voltage drops.
- Device response time: 90 ms ±5
- Operating threshold:
  - opening: 0.35 to 0.7 x Un
  - closing: 0.85 x Un
- Consumption:
  - pick-up (80 ms): 200 VA
  - hold: 4.5 VA.

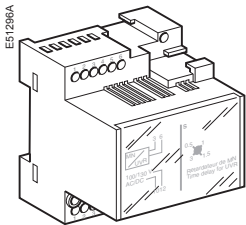

## Delay unit for MN releases

- Optional accessory, 1 MNR with delay unit per device.
- Delay-unit (must be ordered in addition to the MN):
  - 48/60 V AC 50/60 Hz / DC
  - 100/130 V AC 50/60 Hz / DC
  - 200/250 V AC 50/60 Hz / DC
  - 380/480 V AC 50/60 Hz / DC.
- The unit delays operation of the MN release to eliminate circuit-breaker nuisance tripping during short voltage dips
- The unit is wired in series with the MN and must be installed outside the circuit breaker.
- Device response time: 0.5, 1, 1.5, 3 seconds
- Operating threshold:
  - opening: 0.35 to 0.7 x Un
  - closing: 0.85 x Un
- Consumption:
  - pick-up (80 ms): 200 VA
  - hold: 4.5 VA.

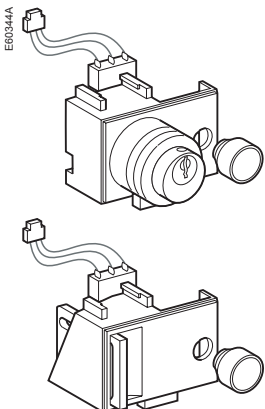

## Electrical closing pushbutton (BPFE)

- Optional accessory, 1 BPFE per device
- Located on the padlock or keylock locking system, this pushbutton carries out electrical closing of the circuit breaker via the XF release, taking into account all the safety functions that are part of the control/monitoring system of the installation
- It connects to the input of the COM option.

# Auxiliaries for remote operation

## Wiring of control auxiliaries

Under pick-up conditions, the level of consumption is approximately 150 to 200 VA. Consequently, for low supply voltages (12, 24, 48 V), cables must not exceed a maximum length determined by the supply voltage and the cross-section of the cables.

### Indicative values for maximum cable lengths (in meters)

		12 V		24 V		48 V	
		2.5 mm <sup>2</sup>	1.5 mm <sup>2</sup>	2.5 mm <sup>2</sup>	1.5 mm <sup>2</sup>	2.5 mm <sup>2</sup>	1.5 mm <sup>2</sup>
<b>MN</b>	100 % source voltage	—	—	58	36	280	165
	85 % source voltage	—	—	16	10	75	45
<b>MX-XF</b>	100 % source voltage	21	12	115	70	550	330
	85 % source voltage	10	6	75	44	350	210

**Note:** The indicated length is that for each of the two supply wires.

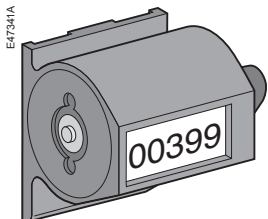

## Operation counter (CDM)

- Optional accessory, one CDM per device
- The operation counter sums the number of operating cycles.

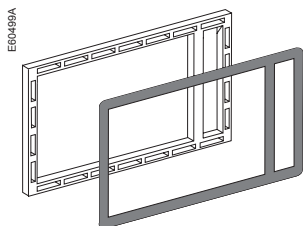

## Escutcheon (CDP)

- Optional accessory, one CDP per device
  - for fixed device
  - for drawout device.
- The CDP increases the degree of protection to IP 40 and IK 07 (fixed and drawout devices).

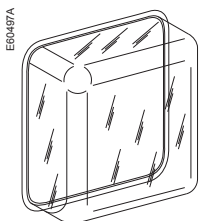

## Transparent cover (CCP)

- Optional accessory, one CCP per device equipped with a CDP
- Mounted with a CDP, the CCP increases the degree of protection to IP 54 and IK 10 (fixed and drawout devices).



## Blanking plate (OP)

- Optional accessory, one OP per device
- Used with the escutcheon, this option closes off the door cut-out of a cubicle not yet equipped with a device. It may be used with the escutcheon for both fixed and drawout devices.

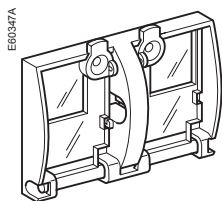

## Transparent cover for pushbutton locking using a padlock, lead seal or screws

- Optional accessory, one locking cover per device
- The transparent cover blocks access (together or separately) to the pushbuttons used to open and close the device
- Locking requires a padlock, a lead seal or two screws.

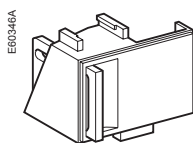

## Device locking in the OFF position using a padlock

- Optional accessory, one locking system per device
- The unit inhibits local or remote closing of the device
- Up to three padlocks may be used for locking.

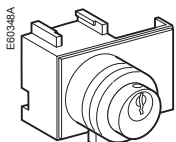

## Device OFF position locking kit for keylocks

- Optional accessory: one locking kit (without keylock) per device
- Locks not included:
  - for Profalux keylocks
  - for Ronis keylocks
  - for Castell keylocks
  - for Kirk keylocks.
- The kit inhibits local or remote closing of the device
- Mounted on the chassis and accessible with the door closed, this system locks the circuit breaker in "disconnected" position using one or two keylocks.

### Ronis

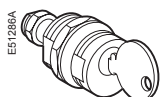

### Profalux

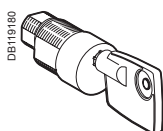

## Keylocks required for the device OFF position locking kit:

- One keylock per device, Ronis or Profalux type.
- Adaptation kits alone are available for Castell and Kirk keylocks.

Top shutter closed

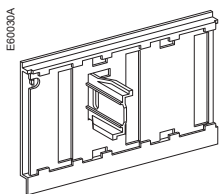

Bottom shutter closed

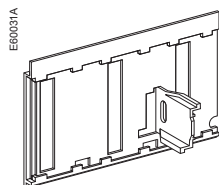

## Safety shutters

■ Standard accessories, provided on every chassis.

■ The safety shutters automatically block the access to the disconnecting contact cluster when the device is in the "disconnected" or "test" positions.

■ IP 20 for chassis connections  
 ■ IP 40 for the disconnecting contact cluster.

If specified when ordering the chassis, this locking function may be adapted to operate in all positions ("connected", "test" and "disconnected"), instead of in "disconnected" position alone.

## Chassis breaker locking in "disconnected" position

■ Optional accessory, one locking system per device  
 for Profalux or Ronis keylocks  
 for Castell keylocks  
 for Kirk keylocks.

■ Mounted on the chassis and accessible with the door closed, this system locks the chassis in "disconnected" position using one or two keylocks.

Ronis

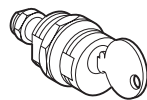
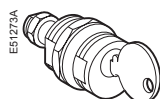
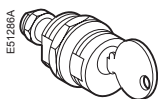

Profalux

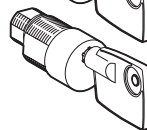
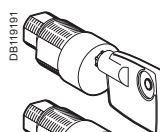
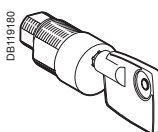

## Keylocks required with the "disconnected" position locking system

■ One or two keylocks per locking system  
 Ronis:  
 1 keylock  
 1 keylock + one identical keylock  
 2 different key locks  
 Profalux:  
 1 keylock  
 1 keylock + one identical keylock  
 2 different key locks.  
 ■ Adaptation kits alone are available for Kirk and Castell keylocks.



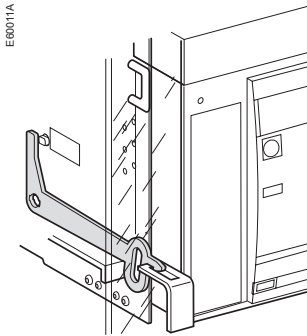

## Door interlock

- Optional accessory, one door interlock per chassis
- This device inhibits opening of the cubicle door when the circuit breaker is in "connected" or "test" position.
- It may be mounted on the left or right-hand side of the chassis.

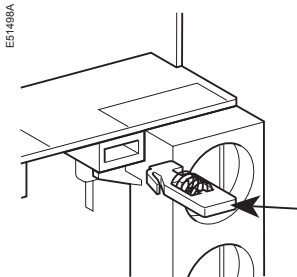

## Racking interlock

- Optional accessory, one racking interlock per chassis
- This device prevents insertion of the racking handle when the cubicle door is open.
- It is mounted on the right-hand side of the chassis.

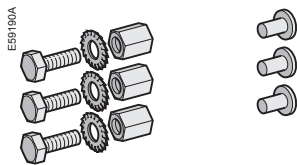

## Mismatch protection

- Optional accessory, one mismatch protection device per chassis
- Mismatch protection offers twenty different combinations that the user may select to ensure that only a compatible circuit breaker is mounted on a given chassis.

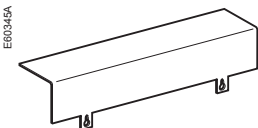

## Auxiliary terminal shield (CB)

- Optional accessory, one CB shield per chassis
- The shield prevents access to the terminal block of the electrical auxiliaries.

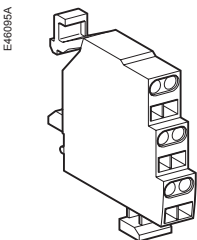

## "Connected", "disconnected" and "test" position carriage switches (CE, CD, CT)

- Optional accessories, one to six carriage switches
- Standard configuration, 0 to 3 CE, 0 to 2 CD, 0 to 1 CT
- The carriage switches indicate the three positions:  
CE: connected position  
CD: disconnected position (when the minimum isolation distance between the main contacts and the auxiliary contacts is reached)  
CT: test position.
- Changeover contact
- Breaking capacity at  $\cos \varphi = 0.3$  (AC12 / DC12 as per IEC 60947-5-1)
  - standard, minimum current 10 mA / 24 V

V AC	240	8 A (rms)
	380	8 A (rms)
	480	8 A (rms)
	690	6 A (rms)
V DC	24/48	2.5 A
	125	0.8 A
	250	0.3 A

□ low level, minimum current 1 mA / 4 V		
V AC	24/48	5 A (rms)
	240	5 A (rms)
	380	5 A (rms)
V DC	24/48	2.5 A
	125	0.8 A
	250	0.3 A

These operations must be carried out in particular before using a Masterpact device for the first time.

A general check of the circuit breaker takes only a few minutes and avoids any risk of mistakes due to errors or negligence.

A general check must be carried out:

- prior to initial use
- following an extended period during which the circuit breaker is not used.

A check must be carried out with the entire switchboard de-energised.

In switchboards with compartments, only those compartments that may be accessed by the operators must be de-energised.

### Electrical tests

Insulation and dielectric-withstand tests must be carried out immediately after delivery of the switchboard. These tests are precisely defined by international standards and must be directed and carried out by a qualified expert.

Prior to running the tests, it is absolutely necessary to:

- disconnect all the electrical auxiliaries of the circuit breaker (MCH, MX, XF, MN, Res electrical remote reset)
- remove the long-time rating plug on the 7.0 A, 5.0 P, 6.0 P, 7.0 P, 5.0 H, 6.0 H, 7.0 H control units. Removal of the rating plug disconnects the voltage measurement input.

### Switchboard inspection

Check that the circuit breakers are installed in a clean environment, free of any installation scrap or items (tools, electrical wires, broken parts or shreds, metal objects, etc.).

### Conformity with the installation diagram

Check that the devices conform with the installation diagram:

- breaking capacities indicated on the rating plates
- identification of the control unit (type, rating)
- presence of any optional functions (remote ON/OFF with motor mechanism, auxiliaries, measurement and indication modules, etc.)
- protection settings (long time, short time, instantaneous, earth fault)
- identification of the protected circuit marked on the front of each circuit breaker.

### Condition of connections and auxiliaries

Check device mounting in the switchboard and the tightness of power connections.

Check that all auxiliaries and accessories are correctly installed:

- electrical auxiliaries
- terminal blocks
- connections of auxiliary circuits.

### Operation

Check the mechanical operation of the circuit breakers:

- opening of contacts
- closing of contacts.

### Check on the control unit

Check the control unit of each circuit breaker using the respective user manuals.

# What to do when the circuit breaker trips

---

## Note the fault

Faults are signalled locally and remotely by the indicators and auxiliary contacts installed on circuit breakers (depending on each configuration). See page 12 in this manual and the user manual of the control unit for information on the fault indications available with your circuit breaker.

## Identify the cause of tripping

A circuit must never be reclosed (locally or remotely) before the cause of the fault has been identified and cleared.

A fault may have a number of causes:

- depending on the type of control unit, fault diagnostics are available. See the user manual for the control unit.
- depending on the type of fault and the criticality of the loads, a number of precautionary measures must be taken, in particular the insulation and dielectric tests on a part of or the entire installation. These checks and test must be directed and carried out by qualified personnel.

## Inspect the circuit breaker following a short-circuit

- Check the arc chutes (see page 43)
- Check the contacts (see page 43)
- Check the tightness of connections (see the device installation manual)
- Check the disconnecting-contact clusters (see page 43).

## Reset the circuit breaker

The circuit breaker can be reset locally or remotely. See page 12 in this manual for information on how the circuit breaker can be reset.

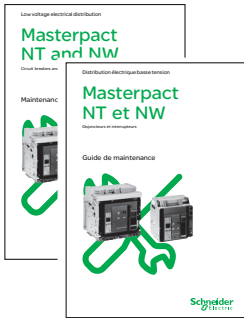

LVPED508016EN  
LVPED508016FR

**Keep your Masterpact NT/NW features year after year by performing requested maintenance.**

To ensure that your protective device retains the operating and safety characteristics specified in the catalogs for the whole of its service life, Schneider Electric recommends that routine inspections and periodic maintenance should be carried out by qualified personnel in accordance with the instructions in the Masterpact maintenance guide.

**The Maintenance Guide LVPED508016EN can be downloaded from the [www.schneider-electric.com](http://www.schneider-electric.com) website and provides detailed information on:**

- the types of maintenance required, depending on the criticality of the protected circuit
  - the risks involved if the component ceases to operate correctly
  - what is understood by the terms normal, improved and severe environment and operating conditions
  - the periodic preventive maintenance operations that should be carried out under normal environment and operating conditions as well as the level of competence required for the operations
  - the environment and operating conditions that accelerate device ageing.
- The level II and III procedures mentioned in the Maintenance Guide can be downloaded from the [www.schneider-electric.com](http://www.schneider-electric.com) website. They are compiled in a document with reference HRB16483.



Problem	Probable causes	Solutions
Circuit breaker cannot be closed locally or remotely	<ul style="list-style-type: none"> <li>■ Circuit breaker padlocked or keylocked in the "open" position</li> <li>■ Circuit breaker interlocked mechanically in a source changeover system</li> <li>■ Circuit breaker not completely connected</li> <li>■ The reset button signalling a fault trip has not been reset</li> <li>■ Stored energy mechanism not charged</li> <li>■ MX opening shunt release permanently supplied with power</li> <li>■ MN undervoltage release not supplied with power</li> <li>■ XF closing release continuously supplied with power, but circuit breaker not "ready to close" (XF not wired in series with PF contact)</li> <li>■ Permanent trip order in the presence of a Micrologic P or H control unit with minimum voltage and minimum frequency protection in Trip mode and the control unit powered</li> </ul>	<ul style="list-style-type: none"> <li>□ disable the locking fonction</li> <li>□ check the position of the other circuit breaker in the changeover system</li> <li>□ terminate racking in (connection) of the circuit breaker</li> <li>□ clear the fault</li> <li>□ push the reset button on the front of the circuit breaker</li> <li>□ charge the mechanism manually</li> <li>□ if it is equipped with a an MCH gear motor, check the supply of power to the motor. If the problem persists, replace the gear motor (MCH)</li> <li>□ there is an opening order. Determine the origin of the order. The order must be cancelled before the circuit breaker can be closed</li> <li>□ there is an opening order. Determine the origin of the order.</li> <li>□ check the voltage and the supply circuit (<math>U &gt; 0.85 U_n</math>).</li> <li>If the problem persists, replace the release</li> <li>□ cut the supply of power to the XF closing release, then send the closing order again via the XF, but only if the circuit breaker is "ready to close"</li> <li>□ Disable these protection functions on the Micrologic P or H control unit</li> </ul>
Circuit breaker cannot be closed remotely but can be opened locally using the closing pushbutton	<ul style="list-style-type: none"> <li>■ Closing order not executed by the XF closing release</li> </ul>	<ul style="list-style-type: none"> <li>□ check the voltage and the supply circuit (<math>0.85 - 1.1 U_n</math>).</li> <li>If the problem persists, replace the XF release</li> </ul>
Unexpected tripping without activation of the reset button signalling a fault trip	<ul style="list-style-type: none"> <li>■ MN undervoltage release supply voltage too low</li> <li>■ Load-shedding order sent to the MX opening release by another device</li> <li>■ Unnecessary opening order from the MX opening release</li> </ul>	<ul style="list-style-type: none"> <li>□ check the voltage and the supply circuit (<math>U &gt; 0.85 U_n</math>)</li> <li>□ check the overall load on the distribution system</li> <li>□ if necessary, modify the settings of devices in the installation</li> <li>□ determine the origin of the order</li> </ul>
Unexpected tripping with activation of the reset button signalling a fault trip	<p>A fault is present :</p> <ul style="list-style-type: none"> <li>■ overload</li> <li>■ earth fault</li> <li>■ short-circuit detected by the control unit</li> </ul>	<ul style="list-style-type: none"> <li>□ determine and clear the causes of the fault</li> <li>□ check the condition of the circuit breaker before putting it back into service</li> </ul>
Instantaneous opening after each attempt to close the circuit breaker with activation of the reset button signalling a fault trip	<ul style="list-style-type: none"> <li>■ Thermal memory</li> <li>■ Transient overcurrent when closing</li> <li>■ Closing on a short-circuit</li> </ul>	<ul style="list-style-type: none"> <li>□ see the user manual of the control unit</li> <li>□ press the reset button</li> <li>□ modify the distribution system or the control-unit settings</li> <li>□ check the condition of the circuit breaker before putting it back into service</li> <li>□ press the reset button</li> <li>□ clear the fault</li> <li>□ check the condition of the circuit breaker before putting it back into service</li> <li>□ press the reset button</li> </ul>

Problem	Probable causes	Solutions
Circuit breaker cannot be opened remotely, but can be opened locally	<ul style="list-style-type: none"> <li>■ Opening order not executed by the MX opening release</li> <li>■ Opening order not executed by the MN undervoltage release</li> </ul>	<ul style="list-style-type: none"> <li>□ check the voltage and the supply circuit (0.7 - 1.1 Un). If the problem persists, replace the MX release</li> <li>□ drop in voltage insufficient or residual voltage (&gt; 0.35 Un) across the terminals of the undervoltage release. If the problem persists, replace the MN release</li> </ul>
Circuit breaker cannot be opened locally	<ul style="list-style-type: none"> <li>■ Operating mechanism malfunction or welded contacts</li> </ul>	<ul style="list-style-type: none"> <li>□ contact a Schneider service centre</li> </ul>
Circuit breaker cannot be reset locally but not remotely	<ul style="list-style-type: none"> <li>■ Insufficient supply voltage for the MCH gear motor</li> </ul>	<ul style="list-style-type: none"> <li>□ check the voltage and the supply circuit (0.7 - 1.1 Un). If the problem persists, replace the MCH release</li> </ul>
Nuisance tripping of the circuit breaker with activation of the reset button signalling a fault trip	<ul style="list-style-type: none"> <li>■ Reset button not pushed-in completely</li> </ul>	<ul style="list-style-type: none"> <li>□ push the reset button in completely</li> </ul>
Impossible to insert the crank in connected, test or disconnected position	<ul style="list-style-type: none"> <li>■ A padlock or keylock is present on the chassis or a door interlock is present</li> </ul>	<ul style="list-style-type: none"> <li>□ disable the locking function</li> </ul>
Impossible to turn the crank	<ul style="list-style-type: none"> <li>■ The reset button has not been pressed</li> </ul>	<ul style="list-style-type: none"> <li>□ press the reset button</li> </ul>
Circuit breaker cannot be removed from chassis	<ul style="list-style-type: none"> <li>■ Circuit breaker not in disconnected position</li> </ul>	<ul style="list-style-type: none"> <li>□ turn the crank until the circuit breaker is in disconnected position and the reset button out</li> </ul>
Circuit breaker cannot be connected (racked in)	<ul style="list-style-type: none"> <li>■ The rails are not completely out</li> <li>■ Cradle/circuit breaker mismatch protection</li> <li>■ The safety shutters are locked</li> <li>■ The disconnecting-contact clusters are incorrectly positioned</li> <li>■ Cradle locked in disconnected position</li> <li>■ The reset button has not been pressed, preventing rotation of the crank</li> <li>■ The circuit breaker has not been sufficiently inserted in the cradle</li> </ul>	<ul style="list-style-type: none"> <li>□ pull the rails all the way out</li> <li>□ check that the cradle corresponds with the circuit breaker</li> <li>□ remove the lock(s)</li> <li>□ reposition the clusters</li> <li>□ disable the cradle locking function</li> <li>□ press the reset button</li> <li>□ insert the circuit breaker completely so that it is engaged in the racking mechanism</li> </ul>
Circuit breaker cannot be locked in disconnected position	<ul style="list-style-type: none"> <li>■ The circuit breaker is not in the right position</li> <li>■ The crank is still in the cradle</li> </ul>	<ul style="list-style-type: none"> <li>□ check the circuit breaker position by making sure the reset button is out</li> <li>□ remove the crank and store it</li> </ul>
Circuit breaker cannot be locked in connected, test or disconnected position	<ul style="list-style-type: none"> <li>■ Check that locking in any position is enabled</li> <li>■ The circuit breaker is not in the right position</li> <li>■ The crank is still in the cradle</li> </ul>	<ul style="list-style-type: none"> <li>□ contact a Schneider Electric service centre</li> <li>□ check the circuit breaker position by making sure the reset button is out</li> <li>□ remove the crank and store it</li> </ul>

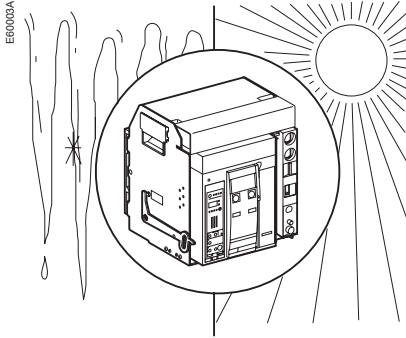

## Ambient temperature

Masterpact NT devices can operate under the following temperature conditions:

- the electrical and mechanical characteristics are stipulated for an ambient temperature of -25 °C to +70 °C
- circuit-breaker mechanical closing by pushbutton is guaranteed down to -35 °C
- Masterpact NW (without the control unit) can be stored in an ambient temperature of -40 °C to +85 °C
- the control unit can be stored in an ambient temperature of -25 °C to +85 °C.

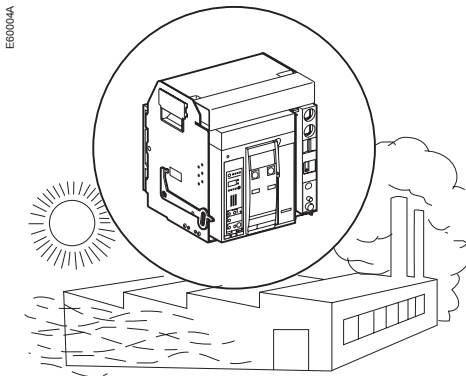

## Extreme atmospheric conditions

Masterpact NT devices have successfully passed the tests defined by the following standards for extreme atmospheric conditions:

- IEC 60068-2-1: dry cold at -40 °C
- IEC 60068-2-2: dry heat at +85 °C
- IEC 60068-2-30: damp heat (temperature +55 °C, relative humidity 95 %)
- IEC 60068-2-52 level 2: salt mist.

Masterpact NT devices can operate in the industrial environments defined by standard IEC 60947 (pollution degree up to 4).

It is nonetheless advised to check that the devices are installed in suitably cooled switchboards without excessive dust.

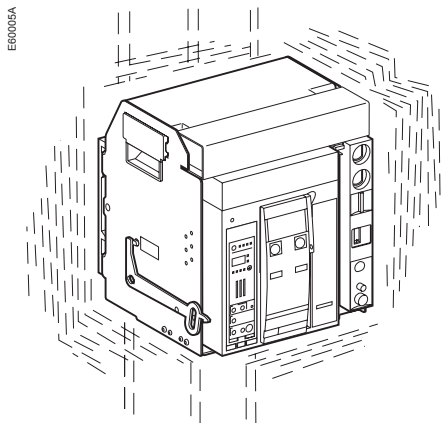

## Vibrations

Masterpact NT devices resist electromagnetic or mechanical vibrations.

Tests are carried out in compliance with standard IEC 60068-2-6 for the levels required by merchant-marine inspection organisations (Veritas, Lloyd's, etc.):

- 2 to 13.2 Hz: amplitude  $\pm 1$  mm
- 13.2 to 100 Hz: constant acceleration 0.7 g.

Excessive vibration may cause tripping, breaks in connections or damage to mechanical parts.

Some applications have vibration profiles outside of this standard, and require special attention during application design, installation, and use. Excessive vibration may cause unexpected tripping, damage to connections or to other mechanical parts. Please refer to the Masterpact maintenance guide (causes of accelerated ageing / operating conditions / vibrations) for additional information.

Examples of applications with high vibration profiles could include:

- wind turbines
- power frequency converters that are installed in the same switchboard or close proximity to the Masterpact circuit breaker
- emergency generators
- high vibration marine applications such as thrusters, anchor positioning systems, etc.



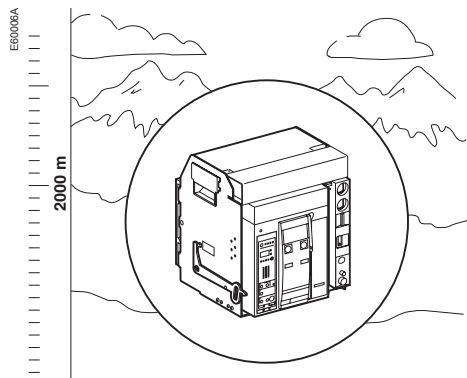

## Altitude

Masterpact NT devices are designed for operation at altitudes under 2000 metres. At altitudes higher than 2000 metres, the modifications in the ambient air (electrical resistance, cooling capacity) lower the following characteristics.

Altitude (m)	2000	3000	4000	5000
<b>Dielectric withstand voltage (V)</b>	3500	3150	2500	2100
<b>Rated insulation level (V)</b>	1000	900	700	600
<b>Rated operational voltage (V)</b>	690	590	520	460
<b>Rated current (A) at 40 °C</b>	1 x I <sub>n</sub>	0.99 x I <sub>n</sub>	0.96 x I <sub>n</sub>	0.94 x I <sub>n</sub>

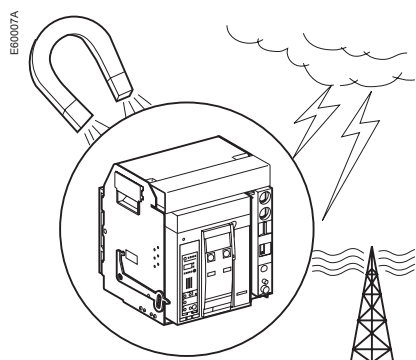

## Electromagnetic disturbances

Masterpact NT devices are protected against:

- overvoltages caused by devices that generate electromagnetic disturbances
- overvoltages caused by an atmospheric disturbance or by a distribution-system outage (e.g. failure of a lighting system)
- devices emitting radio waves (radios, walkie-talkies, radar, etc.)
- electrostatic discharges produced by users.

Masterpact NT devices have successfully passed the electromagnetic-compatibility tests (EMC) defined by the following international standards:

- IEC 60947-2, appendix F
- IEC 60947-2, appendix B (trip units with earth-leakage function).

The above tests guarantee that:

- no nuisance tripping occurs
- tripping times are respected.

## Cleaning

- **Non-metallic parts:**  
never use solvent, soap or any other cleaning product. Clean with a dry cloth only
- **Metal parts:**  
clean with a dry cloth whenever possible. If solvent, soap or any other cleaning product must be used, make sure that it does not come into contact with non-metallic parts.

# Notes

---



**Schneider Electric Industries SAS**

35, rue Joseph Monier  
CS 30323  
F - 92506 Rueil Malmaison Cedex

[www.schneider-electric.com](http://www.schneider-electric.com)

As standards, specifications and designs change from time to time, please ask for confirmation of the information given in this publication.



*This document has been printed on ecological paper*

Design: Schneider Electric  
Photos: Schneider Electric  
Printed: