

Multi-Loader

Simplified manual

04/2010



www.schneider-electric.com

Important information

1

NOTICE

Read these instructions carefully, and look at the equipment to become familiar with the device before trying to install, operate, or maintain it. The following special messages may appear throughout this documentation or on the equipment to warn of potential hazards or to call attention to information that clarifies or simplifies a procedure.

The addition of this symbol to a Danger or Warning safety label indicates that an electrical hazard exists, which will result in personal injury if the instructions are not followed.

This is the safety alert symbol. It is used to alert you to potential personal injury hazards. Obey all safety messages that follow this symbol to avoid possible injury or death.

⚠️ DANGER

HAZARD OF ELECTRIC SHOCK, EXPLOSION, OR ARC FLASH

- Read and understand this manual before using the Multi-Loader. Operation of the Multi-Loader must be performed by qualified personnel.
- Read and understand the installation and programming manuals applicable to the drive that you are using with the Multi-Loader. Installation, adjustment, repair, and maintenance must be performed by qualified personnel.
- The user is responsible for compliance with all international and national electrical code requirements with respect to grounding the equipment.
- Many parts in this drive, including the printed circuit boards, operate at the line voltage. DO NOT TOUCH. Use only electrically insulated tools.
- DO NOT touch unshielded components or terminal strip screw connections with voltage present.
- DO NOT short across terminals PA+/ and PC/- or across the DC bus capacitors.
- Install and close all covers before applying power or starting and stopping the drive.

Failure to follow these instructions will result in death or serious injury.

PLEASE NOTE

The word "drive" as used in this manual refers to the controller portion of the adjustable speed drive as defined by NEC.

Electrical equipment should be installed, operated, serviced, and maintained only by qualified personnel. No responsibility is assumed by Schneider Electric for any consequences arising out of the use of this product.

© 2009 Schneider Electric. All Rights Reserved

Setup procedure

2

1. Receive and inspect the Multi-Loader

Check that the reference printed on the label is the same as that on the purchase order.

Remove the Multi-Loader from its packaging and check that it has not been damaged in transit.

- Presentation. (see page 4)
- Description. (see page 5 and 6)

2. Connect the Multi-Loader

- To a PC. (see page 7)
- To a device. (see page 8)

3. Duplicate device configurations

- Load a configuration onto the Multi-Loader. (see page 9)
- Transfer a configuration to a device. (see page 10)
- Transfer a configuration to several devices : Quick Store (see page 10)

4. Multi-Loader main menu (see page 11)

5. Diagnostic (see page 13)



For complete documentation, refer to www.schneider-electric.com

Before you begin

Read and understand these instructions before performing any procedure with this product

⚠️ DANGER

UNINTENDED EQUIPMENT OPERATION

- Read and understand this manual before installing or operating the Multi-loader.
- Any changes made to a device using the Multi-loader must be performed by qualified personnel.
- Read and understand the device manuals before you load or duplicate the Configuration from one device to another device.
- Ensure that you select the Configuration suitable for your application

Failure to follow these instructions will result in death or serious injury.

Introduction

3

The Multi-Loader is a standalone tool for transferring configuration files to devices with their power on or off.

- The Multi-Loader is used to set device parameters by loading a configuration file onto the device(s). (Devices must have the same reference. A consistency check is performed before the data transfer). On some devices the parameters can be set with them still in their box or before they are powered up.
 - This portable tool has been designed to load up to fifty devices a day and has a battery life of six days. However, this depends on the transfer time, the size of the configuration files and other parameters associated with the settings for the Multi-Loader and the connected devices.
 - It can configure ten drives in less than five minutes.
 - The Multi-Loader can provide the power supply for certain devices if they are turned off during the transfer.
- The Multi-Loader is also a firmware update tool.
 - The "Password FW" mode can be used to protect against incorrect operation by means of a password.

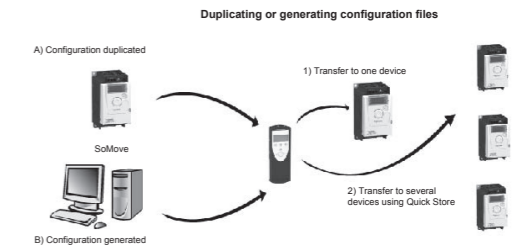

A) The device's configuration file is copied to the Multi-Loader's SD card. (See page 9)

B) The configuration file is generated by SoMove then transferred to the Multi-Loader's SD card.

1) The user selects and then transfers the configuration file from the Multi-Loader to the device. (See page 10 step 1 to 3)

2) Once the initial transfer is complete, the user can use Quick Store mode, which allows the Multi-Loader to load the same update file on several devices in succession. (See page 10 step 1 to 4)

All representations of the ATV12 drive throughout this document are given by way of example only to symbolize a device. Please refer to the device compatibility on the **User Manual**, available online at www.schneider-electric.com.

Receipt of the Multi-Loader

4

Presentation

Product reference:

Check that the product reference printed on the label is the same as that on the delivery note. This should also correspond with the number on the purchase order.

Contents of the Multi-Loader box (VW3A8121)

Check that the Multi-Loader box contains the following:

- 1 x Multi-Loader
- 4 x LR6 (AA) batteries
- 1 x SD card
- 1 x Standard USB type A to Mini-B cable
- 1 x RJ45 (RJ45/RJ45) cable
- 1 x RJ45 female/female adapter (VW3A1105)
- 1 x Carry case
- 1 x Simplified manual (English and French)
- 1 x Impact resistant cover

Available as an option

- Multi-Loader Cordset (VW3A8126)

Weight

250 grams (including batteries)

Data storage

One SD card is supplied with the Multi-Loader. Any standard SD card is compatible with the tool.

Language

The menus are in English, Japanese, French, German, Italian or Spanish.

Power supplies

Two options are available for powering the Multi-Loader:

- 1) With internal power supply:
 - 4 x LR6 (AA) alkaline batteries (batteries included)
 - NiMH rechargeable batteries (batteries and charger not included)
- 2) With external power supply:
 - USB type A to Mini-B cable direct on the PC power supply
 - Through an adaptor wall plug socket / USB type A. (230V~ to 5V ~)

Battery life

Depending on the type of batteries used, the Multi-Loader can transfer up to 300 configuration files.

Power save feature

To prolong battery life, a standby function is activated within a programmable time delay; the Multi-Loader is reactivated by pressing the ON/OFF button. Connection to a powered-up PC or device can also help conserve battery power, as the power supply from the connected device takes over from the batteries.

Receipt of the Multi-Loader

5

Description of the HMI

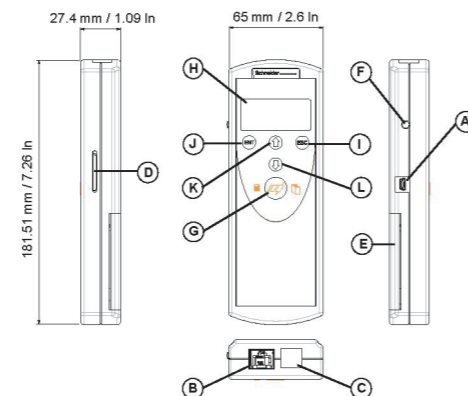

Letter	Description	Comments
A	Mini-B USB connector	The connection between the Multi-Loader (USB Mini-B type) and the PC (USB type A) is via a 1 m (3.28 feet) USB type A to Mini-B cable.
B	RJ 45 connector	The connection between the Multi-Loader and the device is via a RJ45 cable to load and transfer configuration files or updated application
C	RJ11 connector with label cover	This connector is reserved for Schneider Electric product support.
D	SD card slot	The SD card receives and stores the files. One SD card is supplied with the Multi-Loader.
E	Battery compartment	The Multi-Loader can take normal batteries or rechargeable batteries.
F	ON/OFF button	Press for 2 seconds to turn the tool on or off.
G	Quick Store key	Press this key to transfer data from the Multi-Loader to the device after an initial transfer.
H	Screen	The screen comprises 2 lines of 16 characters.
I	ESC key	Returns to the previous screen.
J	ENT key	Confirms the parameter selection or cancels messages.
K	Up arrow key	For menu navigation.
L	Down arrow key	For menu navigation.

Receipt of the Multi-Loader

6

Description of the status Bar.

The drawings below show names and functions of main parts display.

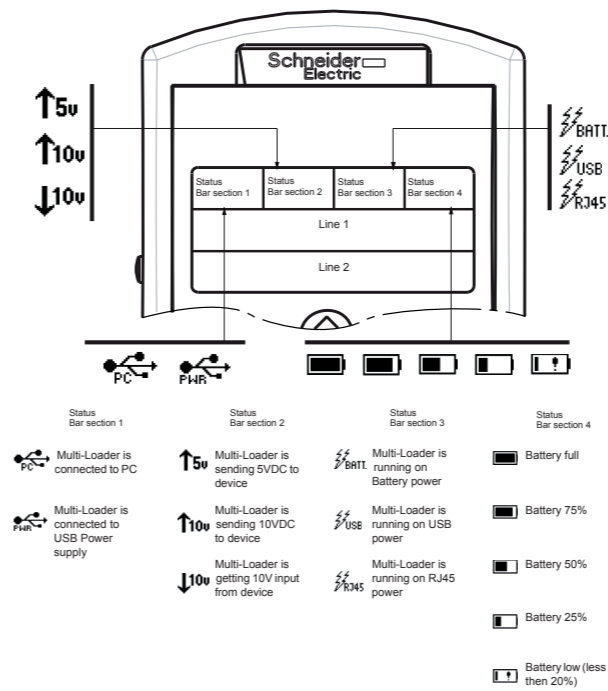

Connecting the Multi-Loader

7

This section describes the various ways of connecting the Multi-Loader.

Connection to a PC

There are two ways of storing files on the SD card:

- Insert the SD card in the Multi-Loader and connect the Multi-Loader to the PC via the standard USB type A to Mini-B cable (see Figure 3 below)
- OR
- Insert the SD card in the SD card reader on the PC (see Figure 4 below)



A: USB type A connector B: USB Mini-B type connector



SD card reader

For both these methods, the SD card is recognized as an external storage device; no driver is required. The SD card operates in Windows Explorer using the same copy/paste actions as any standard external storage medium.

Note :

- The PC must be on and operational before connecting the Multi-Loader to avoid to avoid an incorrect start up of the PC.
- The SD card must not be removed when the Multi-Loader is on and a transfer is in progress. Otherwise, data on the SD card may be lost.
- The file name can have 32 characters and the special characters are forbidden.
- The following priority rules come into play when the Multi-Loader is connected to a PC:
 - If no transfer is in progress between the Multi-Loader and the drive, the connection to the drive is ignored and the Multi-Loader is detected by the PC.
 - If a transfer is in progress between the Multi-Loader and the drive, the user must wait until the transfer is complete. The Multi-Loader should be reconnect to the pc for can be detected.

Source of configuration files

There are two ways of managing configuration files:

- If a device's configuration is to be duplicated, it is copied to another device via the Multi-Loader. See "Loading a configuration from device" on page 9 and "Configuration transfers" on page 10 and 11.
- If the configuration file is generated by SoMove software, it must then be transferred to the Multi-Loader's SD card. See "Downloads" on page 15 and "Connection to a PC" above.

Connection to the graphic terminal (VW3A1101)

The Multi-Loader can be connected to the graphic terminal via its RJ45 female/female adapter (VW3A1105). This adapter is needed for updating the graphic terminal.



Connection to a drive

There are three ways of transferring configuration files.

The drive is in its packaging



When the drive is off, the Multi-Loader is powered by its batteries.

Note: When the drive is in its box, the guiding tool option can be used for quicker and easier in-box connection (no locking tab on the connector), thus speeding up the transfer and keeping the packaging intact.

The drive is mounted, wired, and powered-up or the drive is power on



When the drive is on, the Multi-Loader is powered by the drive via the RJ45 cable.

HAZARD OF ELECTRIC SHOCK, EXPLOSION, OR ARC FLASH - EXPOSURE TO ENERGIZED PARTS

- Adhere to NFPA 70E guidelines when using the Multi-Loader.
- The Multi-Loader is to be used only by qualified personnel as defined in NFPA 70E
- Read and understand the manuals for the applicable drive before accessing the communication port of the drive.
- Ensure that the RJ45 cable is not damaged

Failure to follow these instructions will result in death or serious injury.

Schneider Electric recommends that all power from the drive and enclosures housing the drive is disconnected before performing this procedure. If you choose not to follow this recommendation, you must adhere to NFPA 70E guidelines.

- Remove all power from the drive and all enclosures housing the drive and wait 15 minutes to allow the DC bus of the drive to discharge.
- Insert the Multi-Loader's communication cable into the drive's RJ45 communication port. Refer to the drive's installation manual for more information about how to perform this task.
- Install and close all covers and doors before applying power to the drive. The drive must be powered on before performing an upload or download.
- Perform the desired transfer.
- Upon completing the transfer, remove all power from the drive and the enclosures housing the drive and wait 15 minutes to allow the DC bus of the drive to discharge.
- Remove the Multi-Loader communication cable from the drive.
- Install and close all covers and doors before reapplying power to the drive.
- Confirm that the correct program is in the drive.

Supervision

The diagram below shows the device main menu, accessible from **Main menu / Device**. This supervisory menu is used to check the reference and version of the device connected to the Multi-Loader.

Device Type: This menu accesses the reference of the connected device.

Device SW version: This menu accesses the software version of the connected device.

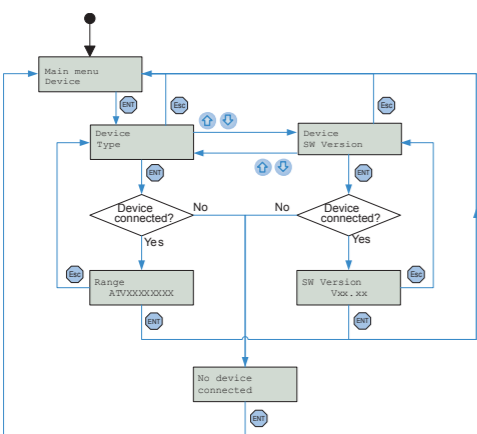

Loading a configuration from a device and more.

This procedure allows the user to retrieve a configuration file (*file.cfg) from a device and load it onto the Multi-Loader's SD card.

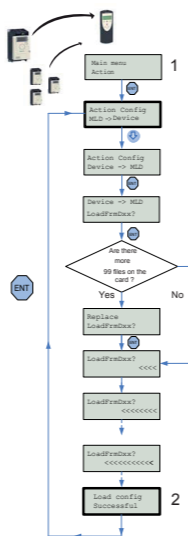

STEP	Actions
1	<ul style="list-style-type: none"> Turn the Multi-Loader on using the ON/OFF button "F" (see page 5). Connect the Multi-Loader to the device using the RJ45 cable (see page 8). Press "ENT" when the screen displays Main menu / Action. Select the Action Config / Device -> MLD menu using the arrow keys and press "ENT". Device -> MLD / LoadFromDevice appears on the screen. Press ENT until the transfer starts.
2	<ul style="list-style-type: none"> Load Config Successful: The configuration has been loaded successfully onto the Multi-Loader; disconnect the RJ45 cable from the device. The device configuration file (*file.cfg) is now loaded onto the Multi-Loader's SD card. Pressing "ENT" returns the user to the "Action Config" menu. For another loading configuration into the Multi-Loader, repeat the step 1 and step 2.

Note 1: The file will be stored in a folder (folder name is the first 5 letters of the device ID) kept in a directory called 'LoadFrmDev' located at root.

Note 2: Loading a configuration from an ATV61/71 device with option board could generate, a short time, the display of [Incorrect config] (CFF) fault on the device during the operation.

Parameter settings: Diagnostics

The diagram below shows the **Parameters / Diagnostic** menu accessible from **Main menu / Parameters**.

Diagnostic / Fault History: This menu accesses the fault history.

Diagnostic / Clear Faults: This menu is used to clear the fault history

HAZARD OF ELECTRIC SHOCK, EXPLOSION, OR ARC FLASH - EXPOSURE TO ENERGIZED PARTS

UNINTENDED EQUIPMENT OPERATION DUE TO TRANSFER INTERRUPTION

If an interruption occurs during the transfer of configuration to the device :

- Identify and correct the cause of interruption.
- Repeat the transfer.

Failure to follow these instructions will result in death or serious injury.

Multi-Loader display	Probable cause	Remedy
Alert: Low Battery Level	The battery charge is low. The appearance of this message depends on the charge level defined by the user.	<ul style="list-style-type: none"> Make sure you have a set of replacement batteries to hand, as the current set have little life left. Remains not enough time of use.
Switch off Low battery	The battery charge is too low. The Multi-Loader will turn off.	<ul style="list-style-type: none"> Replace the batteries immediately. No more transfers can be made.
Store config fault	Incomplete or incorrect transfer to the device	<ul style="list-style-type: none"> Check the RJ45 cable and both of its connectors. Make sure the connection is secure for the duration of the transfer. Restart the transfer operation.
Wrong reference Fault	Bad transfer to the device; the configuration file selected is not compatible with the destination device.	<ul style="list-style-type: none"> Check that the configuration file is compatible with the device to be configured.
Load config fault	Incomplete or incorrect transfer from the Multi-Loader to the device	<ul style="list-style-type: none"> Check the RJ45 cable and both of its connectors. Restart the transfer operation.
Flash FW Fault	Incomplete or incorrect device update	<ul style="list-style-type: none"> Check the RJ45 cable and both of its connectors. Make sure the connection is secure for the duration of the transfer. Restart the transfer operation.
No device connected	The device is not connected or is incorrectly connected.	<ul style="list-style-type: none"> Check the RJ45 cable and both of its connectors. Make sure the connection is secure for the duration of the transfer. Connect the RJ45 cable.
No file selected	No configuration file is selected. There is no file present on the SD card.	<ul style="list-style-type: none"> Select a file to transfer. Follow the procedure for loading configuration files described on page 9).
Wrong password	The password is incorrect.	<ul style="list-style-type: none"> Enter the password correctly (the default password is [000]).
SD card fault	The card is not recognized.	<ul style="list-style-type: none"> Check that the SD card is inserted correctly. Check that the SD card is formatted correctly.

Transferring the configuration to a device and more. (use Quick Store)

HAZARD OF ELECTRIC SHOCK, EXPLOSION, OR ARC FLASH - EXPOSURE TO ENERGIZED PARTS

UNINTENDED EQUIPMENT OPERATION

- Read and understand this manual before installing or operating the Multi-Loader.
- Any changes made to a device using the Multi-Loader must be performed by qualified personnel.
- Read and understand the device manuals before you load or duplicate the Configuration from one device to another device.
- Ensure that you select the Configuration suitable for your application

Failure to follow these instructions will result in death or serious injury.

This procedure allows the user to select the configuration file to be transferred to the device and use the Quick Store function.

The user must already have:

- Loaded the device configuration file (*.cfg) onto the Multi-Loader (see page 9)
- Or
- Generated the configuration file using SoMove and loaded this file onto the Multi-Loader (filename1, filename2, etc.)

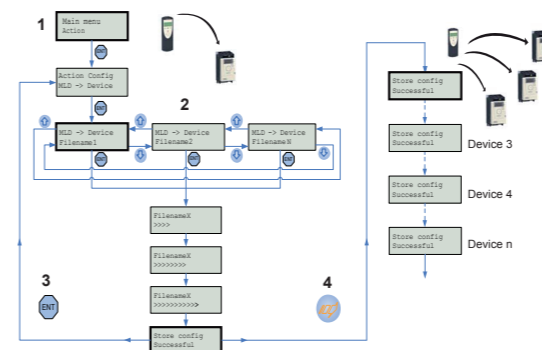

STEP	Transfer
1	<ul style="list-style-type: none"> Turn the Multi-Loader on using the ON/OFF button "F" (see page 5) Connect the Multi-Loader to the device using the RJ45 cable (see page 8) Press "ENT" when the screen displays Main menu / Action. Press "ENT" when the screen displays Action Config / MLD -> Device.
2	<ul style="list-style-type: none"> Select the file to be transferred using the arrow keys and press "ENT" to start the transfer. If no device is connected, a message (No device connected) appears on the screen (see page 12).
3	<ul style="list-style-type: none"> The configuration has been transferred successfully from the Multi-Loader; disconnect the RJ45 cable from the device. Pressing "ENT" returns the user to the "Action Config / MLD -> Device" menu or see STEP 4 for the Quick store.
4	<ul style="list-style-type: none"> Connect the Multi-Loader to the next device, then press the Quick Store key Store Config Successful: The configuration has been loaded successfully onto the second device; remove the RJ45 cable from the device. This action can be carried out as many times as necessary

Note: Storing a configuration to an ATV61/71 device with option board could generate, a short time, the display of [Incorrect config] (CFF) fault on the device during the operation.

HAZARD OF ELECTRIC SHOCK, EXPLOSION, OR ARC FLASH - EXPOSURE TO ENERGIZED PARTS

UNINTENDED EQUIPMENT OPERATION DUE TO TRANSFER INTERRUPTION

If an interruption occurs during the transfer of configuration to the device :

- Identify and correct the cause of interruption.
- Repeat the transfer.

Failure to follow these instructions will result in death or serious injury.

Codes	Display on the Multi-Loader	Codes	Display on the Multi-Loader
General			
Flash FW FAULT - 0x01	Wrong memory write detected	Specific Lexium 32	
Flash FW FAULT - 0x02	Wrong check at the end of the upgrade detected	Flash FW FAULT - 0x85	Wrong program erase detected
Flash FW FAULT - 0x11	Interruption connection detected or wrong file	Flash FW FAULT - 0x86	Wrong program download detected
Flash FW FAULT - 0x12	Missing file on the SD card Path too long	Flash FW FAULT - 0x87	Wrong exit update detected
Flash FW FAULT - 0x13	File in a wrong format (Drives)	Flash FW FAULT - 0x88	Wrong exit verification detected
Flash FW FAULT - 0x14	File in a wrong format (Graphic keypad)	Specific application FW	
Specific graphic keypad			
Flash FW FAULT - 0x9a	Wrong file detected	Flash FW FAULT - 0x21 - 0x31	Wrong communication detected
Flash FW FAULT - 0x9b	Fonts file download failed	Flash FW FAULT - 0x22 - 0x32	Wrong reference detected
Flash FW FAULT - 0x9c	Labels file download failed	Flash FW FAULT - 0x23 - 0x33	Wrong communication detected (baud rate)
Flash FW FAULT - 0x9d	Bitmaps file download failed	Flash FW FAULT - 0x24 - 0x34	Wrong program erase detected
Flash FW FAULT - 0x9e	Internal Error	Flash FW FAULT - 0x25 - 0x35	Wrong program download detected
Flash FW FAULT - 0x9f	Wrong file detected	Specific motor control FW	
Flash FW FAULT - 0xa0	Wrong file detected	Flash FW FAULT - 0x4a	Wrong download detected
Flash FW FAULT - 0xa1	Internal Error2 (Unable to open the file)	Flash FW FAULT - 0x40	Flashing Motor Control is not allowed when the drive is Power On
Flash FW FAULT - 0xa2	Wrong communication detected	Flash FW FAULT - 0x41	Wrong communication detected
Flash FW FAULT - 0xa3	Syntax error of the configuration file	Flash FW FAULT - 0x42	Inquiry device failed
Flash FW FAULT - 0xa4	Wrong file detected	Flash FW FAULT - 0x43	Selection device failed
Flash FW FAULT - 0xa5	Wrong file detected	Flash FW FAULT - 0x44	Inquiry of clock modes failed
Flash FW FAULT - 0xa6	Wrong configuration format file detected	Flash FW FAULT - 0x45	Selection of clock modes failed
Flash FW FAULT - 0xa7	No keypad connected	Flash FW FAULT - 0x46	Inquiry of write line size failed
Flash FW FAULT - 0xa8	Wrong update labels of keypad detected	Flash FW FAULT - 0x47	Wrong communication detected (baud rate)
Specific Lexium 32			
Flash FW FAULT - 0x81	Wrong compatibility detected	Flash FW FAULT - 0x48	End setting data failed
Flash FW FAULT - 0x82	Product not available for upgrade	Flash FW FAULT - 0x49	Wrong memory write detected
Flash FW FAULT - 0x83	Wrong Flash mode set		
Flash FW FAULT - 0x84	Wrong downloader upgrade application		

Multi-Loader main menu

On power-up, the **Multi-Loader / Version "x.x"** menu is displayed on the screen.

The diagram below shows the various menus that can be accessed from the Multi-Loader main menu.

Main menu / Action accesses the following functions:

- Load from Multi-Loader to device
- Load from device to Multi-Loader
- update software of device

Main menu / Device accesses the following information:

- Device type
- Device version

Main menu / Parameters accesses:

- Battery parameters
- Diagnostic parameters
- Password parameters
- Display parameters

Main menu / About MLD accesses:

- Multi-Loader version information

The Quick Store key "Q" (see page 5) allows the user to transfer the most recent configuration file or update to the device.

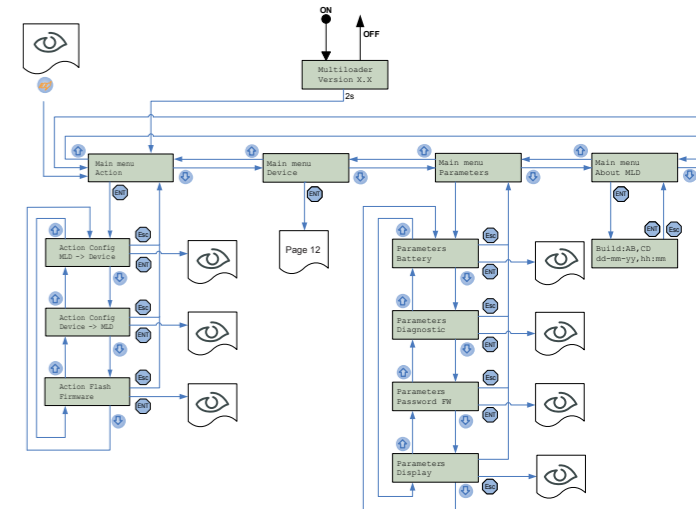

See Multi-Loader user's manual

Note: Quick Store mode is disabled when the Multi-Loader is loading files.