

BSH

Servo Motor

Motor Manual

01/2017



The information provided in this documentation contains general descriptions and/or technical characteristics of the performance of the products contained herein. This documentation is not intended as a substitute for and is not to be used for determining suitability or reliability of these products for specific user applications. It is the duty of any such user or integrator to perform the appropriate and complete risk analysis, evaluation and testing of the products with respect to the relevant specific application or use thereof. Neither Schneider Electric nor any of its affiliates or subsidiaries shall be responsible or liable for misuse of the information contained herein. If you have any suggestions for improvements or amendments or have found errors in this publication, please notify us.

No part of this document may be reproduced in any form or by any means, electronic or mechanical, including photocopying, without express written permission of Schneider Electric.

All pertinent state, regional, and local safety regulations must be observed when installing and using this product. For reasons of safety and to help ensure compliance with documented system data, only the manufacturer should perform repairs to components.

When devices are used for applications with technical safety requirements, the relevant instructions must be followed.

Failure to use Schneider Electric software or approved software with our hardware products may result in injury, harm, or improper operating results.

Failure to observe this information can result in injury or equipment damage.

© 2017 Schneider Electric. All Rights Reserved.

Table of Contents



	Safety Information	5
	About the Book	7
Chapter 1	Introduction	11
	Motor Family	12
	Options and Accessories	12
	Nameplate	13
	Type Code	15
Chapter 2	Technical Data	17
	General Characteristics	18
	Environmental Conditions	20
	Approved Drives	22
	Dimensions	23
	Shaft-Specific Data	34
	Motor-Specific Data	37
	Encoder	49
	Holding Brake	51
	Certifications	52
	Conditions for UL 1004-1, UL 1004-6 and CSA 22.2 No. 100	52
Chapter 3	Installation	53
3.1	Electromagnetic Compatibility (EMC)	55
	Electromagnetic Compatibility (EMC)	55
3.2	Mechanical Installation	57
	Before Mounting	58
	Cable Specifications	60
	Mounting The Motor	63
	Installation and Connection of IP67 Kit (Accessory)	65
3.3	Electrical Installation	66
	Connectors and Connector Assignments	67
	Power and Encoder Connection	71
	Holding Brake Connection	77
Chapter 4	Commissioning	79
	Commissioning	79
Chapter 5	Diagnostics and Troubleshooting	81
	Mechanical Issues	82
	Electrical Issues	82
Chapter 6	Accessories and Spare Parts	83
	IP67 Kit	84
	Connectors	85
	Motor Cables	86
	Encoder Cables	89
Chapter 7	Service, Maintenance, and Disposal	91
	Service Addresses	92
	Maintenance	92
	Replacing the Motor	94
	Shipping, Storage, Disposal	95
Glossary	97
Index	99



Important Information

NOTICE

Read these instructions carefully, and look at the equipment to become familiar with the device before trying to install, operate, service, or maintain it. The following special messages may appear throughout this documentation or on the equipment to warn of potential hazards or to call attention to information that clarifies or simplifies a procedure.



The addition of this symbol to a “Danger” or “Warning” safety label indicates that an electrical hazard exists which will result in personal injury if the instructions are not followed.



This is the safety alert symbol. It is used to alert you to potential personal injury hazards. Obey all safety messages that follow this symbol to avoid possible injury or death.

DANGER

DANGER indicates a hazardous situation which, if not avoided, **will result in** death or serious injury.

WARNING

WARNING indicates a hazardous situation which, if not avoided, **could result in** death or serious injury.

CAUTION

CAUTION indicates a hazardous situation which, if not avoided, **could result in** minor or moderate injury.

NOTICE

NOTICE is used to address practices not related to physical injury.

PLEASE NOTE

Electrical equipment should be installed, operated, serviced, and maintained only by qualified personnel. No responsibility is assumed by Schneider Electric for any consequences arising out of the use of this material.

A qualified person is one who has skills and knowledge related to the construction and operation of electrical equipment and its installation, and has received safety training to recognize and avoid the hazards involved.

About the Book



At a Glance

Document Scope

This manual describes technical characteristics, installation, commissioning, and maintenance of the servo motors BSH.

Validity Note

This manual is valid for the standard products listed in the chapter Type Code.

For product compliance and environmental information (RoHS, REACH, PEP, EOLI, etc.), go to www.schneider-electric.com/green-premium.

The technical characteristics of the devices described in this document also appear online. To access this information online:

Step	Action
1	Go to the Schneider Electric home page www.schneider-electric.com .
2	In the Search box type the reference of a product or the name of a product range. <ul style="list-style-type: none">• Do not include blank spaces in the reference or product range.• To get information on grouping similar modules, use asterisks (*).
3	If you entered a reference, go to the Product Datasheets search results and click on the reference that interests you. If you entered the name of a product range, go to the Product Ranges search results and click on the product range that interests you.
4	If more than one reference appears in the Products search results, click on the reference that interests you.
5	Depending on the size of your screen, you may need to scroll down to see the data sheet.
6	To save or print a data sheet as a .pdf file, click Download XXX product datasheet .

The characteristics that are presented in this manual should be the same as those characteristics that appear online. In line with our policy of constant improvement, we may revise content over time to improve clarity and accuracy. If you see a difference between the manual and online information, use the online information as your reference.

Product Related Information

The use and application of the information contained herein require expertise in the design and programming of automated control systems.

Only you, the user, machine builder or integrator, can be aware of all the conditions and factors present during installation and setup, operation, repair and maintenance of the machine or process.

You must also consider any applicable standards and/or regulations with respect to grounding of all equipment. Verify compliance with any safety information, different electrical requirements, and normative standards that apply to your machine or process in the use of this equipment.

Many components of the equipment, including the printed circuit board, operate with mains voltage, or present transformed high currents, and/or high voltages.

The motor itself generates voltage when the motor shaft is rotated.

DANGER

ELECTRIC SHOCK, EXPLOSION, OR ARC FLASH

- Disconnect all power from all equipment including connected devices prior to removing any covers or doors, or installing or removing any accessories, hardware, cables, or wires.
- Place a "Do Not Turn On" or equivalent hazard label on all power switches and lock them in the non-energized position.
- Wait 15 minutes to allow the residual energy of the DC bus capacitors to discharge.
- Measure the voltage on the DC bus with a properly rated voltage sensing device and verify that the voltage is less than 42.4 Vdc.
- Do not assume that the DC bus is voltage-free when the DC bus LED is off.
- Block the motor shaft to prevent rotation prior to performing any type of work on the drive system.
- Do not create a short-circuit across the DC bus terminals or the DC bus capacitors.
- Replace and secure all covers, accessories, hardware, cables, and wires and confirm that a proper ground connection exists before applying power to the unit.
- Use only the specified voltage when operating this equipment and any associated products.

Failure to follow these instructions will result in death or serious injury.

This equipment has been designed to operate outside of any hazardous location. Only install this equipment in zones known to be free of a hazardous atmosphere.

DANGER

POTENTIAL FOR EXPLOSION

Install and use this equipment in non-hazardous locations only.

Failure to follow these instructions will result in death or serious injury.

If the power stage is disabled unintentionally, for example as a result of a power outage, errors or functions, the motor is no longer decelerated in a controlled way. Overload, errors or incorrect use may cause the holding brake to no longer operate properly and may result in premature wear.

WARNING

UNINTENDED EQUIPMENT OPERATION

- Verify that movements without braking effect cannot cause injuries or equipment damage.
- Verify the function of the holding brake at regular intervals.
- Do not use the holding brake as a service brake.
- Do not use the holding brake for safety-related purposes.

Failure to follow these instructions can result in death, serious injury, or equipment damage.

WARNING

LOSS OF CONTROL

- The designer of any control scheme must consider the potential failure modes of control paths and, for certain critical control functions, provide a means to achieve a safe state during and after a path failure. Examples of critical control functions are emergency stop and overtravel stop, power outage and restart.
- Separate or redundant control paths must be provided for critical control functions.
- System control paths may include communication links. Consideration must be given to the implications of unanticipated transmission delays or failures of the link.
- Observe all accident prevention regulations and local safety guidelines.¹
- Each implementation of this equipment must be individually and thoroughly tested for proper operation before being placed into service.

Failure to follow these instructions can result in death, serious injury, or equipment damage.

¹ For additional information, refer to NEMA ICS 1.1 (latest edition), "Safety Guidelines for the Application, Installation, and Maintenance of Solid State Control" and to NEMA ICS 7.1 (latest edition), "Safety Standards for Construction and Guide for Selection, Installation and Operation of Adjustable-Speed Drive Systems" or their equivalent governing your particular location.

Terminology Derived from Standards

The technical terms, terminology, symbols and the corresponding descriptions in this manual, or that appear in or on the products themselves, are generally derived from the terms or definitions of international standards.

In the area of functional safety systems, drives and general automation, this may include, but is not limited to, terms such as *safety*, *safety function*, *safe state*, *fault*, *fault reset*, *malfunction*, *failure*, *error*, *error message*, *dangerous*, etc.

Among others, these standards include:

Standard	Description
EN 61131-2:2007	Programmable controllers, part 2: Equipment requirements and tests.
ISO 13849-1:2008	Safety of machinery: Safety related parts of control systems. General principles for design.
EN 61496-1:2013	Safety of machinery: Electro-sensitive protective equipment. Part 1: General requirements and tests.
ISO 12100:2010	Safety of machinery - General principles for design - Risk assessment and risk reduction
EN 60204-1:2006	Safety of machinery - Electrical equipment of machines - Part 1: General requirements
EN 1088:2008 ISO 14119:2013	Safety of machinery - Interlocking devices associated with guards - Principles for design and selection
ISO 13850:2006	Safety of machinery - Emergency stop - Principles for design
EN/IEC 62061:2005	Safety of machinery - Functional safety of safety-related electrical, electronic, and electronic programmable control systems
IEC 61508-1:2010	Functional safety of electrical/electronic/programmable electronic safety-related systems: General requirements.
IEC 61508-2:2010	Functional safety of electrical/electronic/programmable electronic safety-related systems: Requirements for electrical/electronic/programmable electronic safety-related systems.
IEC 61508-3:2010	Functional safety of electrical/electronic/programmable electronic safety-related systems: Software requirements.
IEC 61784-3:2008	Digital data communication for measurement and control: Functional safety field buses.
2006/42/EC	Machinery Directive
2014/30/EU	Electromagnetic Compatibility Directive
2014/35/EU	Low Voltage Directive

In addition, terms used in the present document may tangentially be used as they are derived from other standards such as:

Standard	Description
IEC 60034 series	Rotating electrical machines
IEC 61800 series	Adjustable speed electrical power drive systems
IEC 61158 series	Digital data communications for measurement and control – Fieldbus for use in industrial control systems

Finally, the term *zone of operation* may be used in conjunction with the description of specific hazards, and is defined as it is for a *hazard zone* or *danger zone* in the *Machinery Directive (2006/42/EC)* and *ISO 12100:2010*.

NOTE: The aforementioned standards may or may not apply to the specific products cited in the present documentation. For more information concerning the individual standards applicable to the products described herein, see the characteristics tables for those product references.

Chapter 1

Introduction

What Is in This Chapter?

This chapter contains the following topics:

Topic	Page
Motor Family	12
Options and Accessories	12
Nameplate	13
Type Code	15

Motor Family

The series BSH motors are low-inertia AC synchronous servo motors designed for highly dynamic positioning tasks.

A drive system consists of the servo motor and the appropriate drive (*see page 22*). Maximum performance requires the motor and drive to be adapted to each other.

Characteristics

The motors have the following features:

- Overload protection by integrated temperature sensor (external evaluation required)
- Low moment of inertia
- High power density
- Excellent dynamics
- High overload capability
- Broad torque range
- Special winding for low phase currents
- Motor connections via circular connectors or terminal box
- Easy commissioning via electronic nameplate in SinCos encoder
- Low maintenance

Options and Accessories

Options

The motors are available with various options such as:

- Various encoder systems
- Holding brake
- Various shaft versions
- Various degrees of protection
- Various lengths
- Various sizes
- Various winding versions
- Various connection versions

Accessories

Refer to the chapter Accessories and Spare Parts (*see page 83*).

Gearboxes adapted to the motor can be found in the Lexium 32 motion control catalog.

Nameplate

BSH040

The nameplate contains the following data:

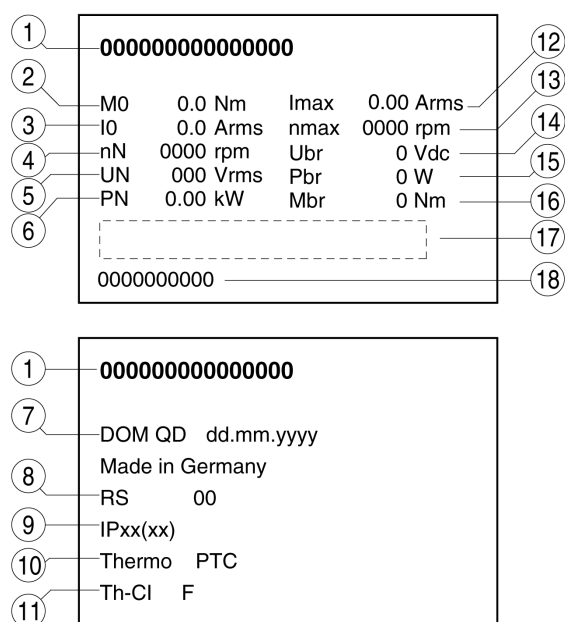

- 1 Motor type, see Type Code (*see page 15*)
- 2 Continuous stall torque
- 3 Continuous stall current
- 4 Nominal speed of rotation
- 5 Maximum nominal value of supply voltage
- 6 Nominal power
- 7 Date of manufacture
- 8 Hardware version
- 9 Degree of protection (housing without shaft bushing)
- 10 Temperature sensor
- 11 Thermal class
- 12 Maximum current
- 13 Maximum speed of rotation
- 14 Nominal voltage holding brake
- 15 Nominal power (electrical pull-in power) holding brake
- 16 Holding torque holding brake
- 17 Barcode
- 18 Serial number

BSH055 ... BSH205

The nameplate contains the following data:

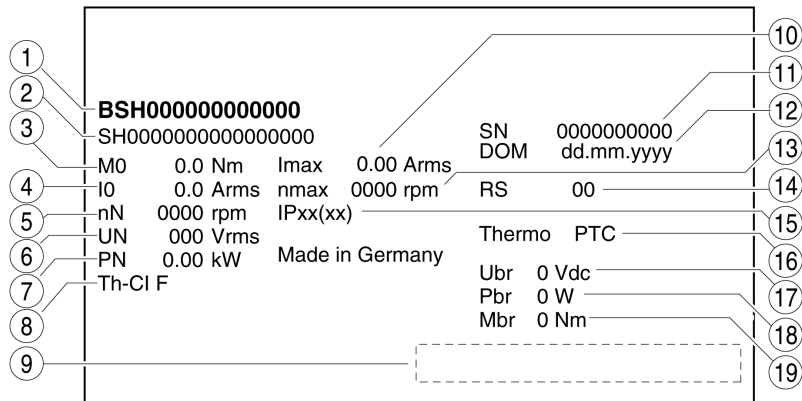

- 1 Motor type, see Type Code (*see page 15*)
- 2 Identification number
- 3 Continuous stall torque
- 4 Continuous stall current
- 5 Nominal speed of rotation
- 6 Maximum nominal value of supply voltage
- 7 Nominal power
- 8 Thermal class
- 9 Barcode
- 10 Maximum current
- 11 Serial number
- 12 Date of manufacture
- 13 Maximum speed of rotation
- 14 Hardware version
- 15 Degree of protection (housing without shaft bushing)
- 16 Temperature sensor
- 17 Nominal voltage holding brake
- 18 Nominal power (electrical pull-in power) holding brake
- 19 Holding torque holding brake

Type Code

Type Code

Item	1	2	3	4	5	6	7	8	9	10	11	12	13
Type code (example)	B	S	H	0	7	0	1	P	0	1	A	1	A

Item	Meaning
1 ... 3	Product family BSH = Synchronous motor - low moment of inertia
4 ... 6	Size (housing) 040 = 40 mm flange 055 = 55 mm flange 070 = 70 mm flange 100 = 100 mm flange 140 = 140 mm flange 205 = 205 mm flange
7	Length 1 = 1 stack 2 = 2 stacks 3 = 3 stacks 4 = 4 stacks
8	Winding M = Optimized in terms of high torque P = Optimized in terms of torque and speed of rotation T = Optimized in terms of high speed of rotation S = Customized version
9	Shaft and degree of protection¹⁾ 0 = Smooth shaft; degree of protection: shaft IP54, housing IP65 1 = Parallel key; degree of protection: shaft IP54, housing IP65 2 = Smooth shaft; degree of protection: shaft and housing IP65 3 = Parallel key; degree of protection: shaft and housing IP65
10	Encoder system 1 = Absolute singleturn 128 Sin/Cos periods per revolution (SKS36) 2 = Absolute multiturn 128 Sin/Cos periods per revolution (SKM36) 6 = Absolute singleturn 16 Sin/Cos periods per revolution (SEK37) 7 = Absolute multiturn 16 Sin/Cos periods per revolution (SEL37)
11	Holding brake A = Without holding brake F = With holding brake
12	Connection version 1 = Straight connector 2 = Angular connector 90°, can be rotated 3 = Terminal box for power and holding brake, 90° angular connector for encoder, can be rotated
13	Mechanical interface - mounting A = International IEC Standard (at motor flange) P = International IEC standard (at motor flange), BSH1402T, BSH1403T and BSH1404P with power connector M40
1) In the case of mounting position IM V3 (drive shaft vertical, shaft end upward), the motor has a degree of protection of IP 50.	

If you have questions concerning the type code, contact your Schneider Electric sales office.

Designation Customized Version

In the case of a customized version, position 8 of the type code is an "S". The subsequent number defines the customized version. Example: B.....S1234

Contact your machine vendor if you have questions concerning customized versions.

Chapter 2

Technical Data

What Is in This Chapter?

This chapter contains the following topics:

Topic	Page
General Characteristics	18
Environmental Conditions	20
Approved Drives	22
Dimensions	23
Shaft-Specific Data	34
Motor-Specific Data	37
Encoder	49
Holding Brake	51
Certifications	52
Conditions for UL 1004-1, UL 1004-6 and CSA 22.2 No. 100	52

General Characteristics

Characteristic	Value	Standard
Motor type	AC synchronous servo motor	-
Thermal class	F (155 °C)	As per IEC 60034-1
Vibration grade	A	As per IEC 60034-14
Test voltage	> 2400 Vac	As per IEC 60034-1
Perpendicularity	normal class	As per IEC 60072-1, DIN 42955
Housing color	Black RAL 9005	-
Overvoltage category	III	As per IEC 61800-5-1
Protection class ¹⁾	I	As per IEC 61140, EN 50178
1) The signals of the holding brake at CN1 and the signals at CN2 meet the PELV requirements.		

Service Life

Bearing service life	Unit	Value
Nominal bearing service life L_{10h} ¹⁾	h	20000
1) Operating hours at a probability of failure of 10%		

The service life of the motors when operated correctly is limited primarily by the service life of the rolling bearing.

The following operating conditions significantly reduce the service life:

- Installation altitude >1000 m (3281 ft) above mean sea level
- Rotary movements exclusively within a fixed angle of <100°
- Operation under vibration load >20 m/s²
- Allowing sealing rings to run dry
- Contact of the seals with aggressive substances

Compressed Air Connection

The compressed air generates a permanent overpressure inside the motor. This overpressure inside the motor is used to obtain degree of protection IP67.

Compressed air must also be available when the system is switched off, for example to maintain the required degree of protection during cleaning work. When the compressed air is switched off, the degree of protection is decreased to IP65. The degree of protection only relates to the motor itself, not to mounted components such as, for example, a gearbox.

Special compressed air must be used:

Characteristic	Unit	Value
Nominal pressure	bar (psi)	0.1 ... 0.3 (1.45 ... 4.35)
Maximum air pressure	bar (psi)	0.4 (5.8)
Permissible humidity	%	20 ... 30
Other properties of the compressed air		Free from dust, free from oil

Tightening Torque and Property Class of Screws

Screw	Unit	Value
Tightening torque of housing screws M3	Nm (lb•in)	1 (8.85)
Tightening torque of housing screws M4	Nm (lb•in)	1.5 (13.28)
Tightening torque of housing screws M5	Nm (lb•in)	5 (44.3)
Tightening torque protective ground conductor M3 (BSH040)	Nm (lb•in)	0.9 (7.97)
Tightening torque protective ground conductor M4 (BSH055, BSH070, BSH100)	Nm (lb•in)	2.9 (25.7)
Tightening torque protective ground conductor M6 (BSH140, BSH205)	Nm (lb•in)	9.9 (87.3)
Property class of the screws	-	8.8

Environmental Conditions

Conditions for Operation

Characteristic	Unit	Value
Class as per IEC 60721-3-3	-	3K3, 3Z12, 3Z2, 3B2, 3C1, 3M6
Ambient temperature ¹⁾ (no icing, non-condensing)	°C (°F)	-20 ... 40 (-4 ... 104)
Ambient temperature with current derating of 1% per °C (per 1.8 °F) ¹⁾	°C (°F)	40 ... 60 (104 ... 140)
Relative humidity (non-condensing)	%	5 ... 85
Installation altitude ²⁾	m (ft)	<1000 (<3281)
Installation altitude with current reduction of 1% per 100 m (328 ft) at altitudes of more than 1000 m (3281 ft) ²⁾³⁾	m (ft)	1000 ... 3000 (3281 ... 9843)
<p>1) Limit values with flanged motor (steel plate, height and width = 2.5 * motor flange, 10 mm (0.39 in) thickness, centered hole).</p> <p>2) The installation altitude is defined in terms of altitude above mean sea level.</p> <p>3) For the correct functioning of the BSH040 motors, you must apply a separate surge protection device when operating between 2000 and 3000 m.</p>		

Conditions for Transportation and Storage

The environment during transportation and storage must be dry and free from dust.

The storage time is primarily limited by the service life of the lubricants in the bearings. Do not store the product for more than 36 months and periodically operate the motor.

If the holding brake is not used for an extended period of time, parts of the holding brake may corrode. Corrosion reduces the holding torque. See chapter Inspecting/Breaking In the Holding Brake (*see page 93*).

Characteristic	Unit	Value
Temperature	°C (°F)	-40 ... 70 (-40 ... 158)
Relative humidity (non-condensing)	%	≤75
Set of class combinations as per IEC 60721-3-2		IE 21

Vibration and Shock

For BSH040 ... BSH140

Characteristic	Value
Vibration, sinusoidal	Type test with 10 runs as per IEC 60068-2-6 0.15 mm (10 ... 60 Hz) 20 m/s ² (60 ... 500 Hz)
Shock, semi-sinusoidal	Type test with 3 shocks in each direction as per IEC 60068-2-27 150 m/s ² (11 ms)

For BSH205

Characteristic	Value
Vibration, sinusoidal	Type test with 10 runs as per IEC 60068-2-6 0.35 mm (10 ... 60 Hz) 50 m/s ² (60 ... 150 Hz)
Continuous shock	Type test with 3 shocks in each direction as per IEC 60068-2-29 200 m/s ² (6 ms)

Compatibility with Foreign Substances

The motor has been tested for compatibility with many known substances and with the latest available knowledge. Nonetheless, you must perform a compatibility test prior to using a foreign substance.

Degree of Protection

Characteristic	Unit	Value
Degree of protection motor housing	IP65	As per IEC 60034-5
Degree of protection shaft bushing without shaft sealing ring	IP54 ¹⁾	As per IEC 60034-5
Degree of protection shaft bushing with shaft sealing ring	IP65 ¹⁾	As per IEC 60034-5
Degree of protection with IP67 kit	IP67 ¹⁾	As per IEC 60034-5
1) In the case of mounting position IM V3 (drive shaft vertical, shaft end up), the motor only has degree of protection IP50. The degree of protection only relates to the motor itself, not to mounted components such as, for example, a gearbox.		

The motors can be equipped with an optional shaft sealing ring. With a shaft sealing ring, they have degree of protection IP65. The shaft sealing ring limits the maximum speed of rotation to 6000 rpm.

Note the following:

- The shaft sealing ring is factory-pre-lubricated.
- If the seals run dry, this increases friction and greatly reduces the service life of the sealing rings.

Approved Drives

Drive systems may perform unintended movements if unapproved combinations of drive and motor are used. Even if motors are similar, different adjustment of the encoder system may be a source of hazards. Even if the connectors for motor connection and encoder connection match mechanically, this does not imply that the motor is approved for use.

WARNING

UNINTENDED MOVEMENT

Only use approved combinations of drive and motor.

Failure to follow these instructions can result in death, serious injury, or equipment damage.

The motor may be operated with the following drives:

Drive	BSH040	BSH055...BSH205
LXM32	✓	✓
LXM15	-	✓
LXM05	-	✓
✓ Approved - Not approved		

When selecting, refer to the drive type and the level of mains voltage to select an appropriate drive product.

In accordance with our continual introduction of new product, consult your local representative for additional compatible drive products as the become available.

Dimensions

Dimensions BSH040

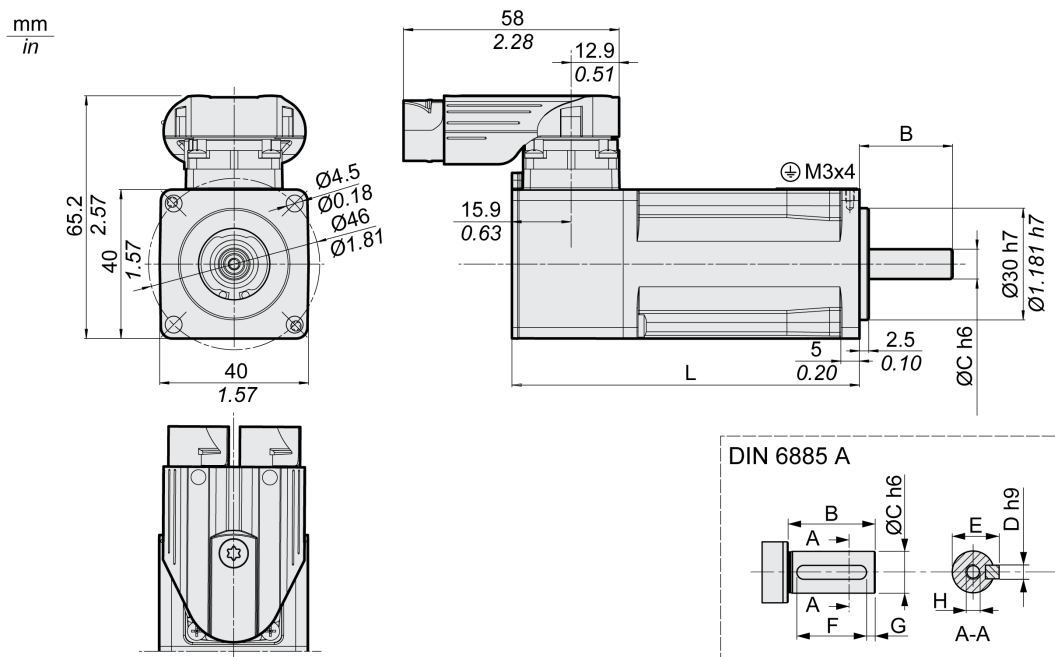

BSH...		0401		0402	
L	Length without holding brake	mm (in)	73.4 (2.89)	93.4 (3.68)	
L	Length with holding brake	mm (in)	99.4 (3.91)	119.4 (4.7)	
B	Shaft length	mm (in)	25 (0.98)	25 (0.98)	
C	Shaft diameter	mm (in)	8 (0.31)	8 (0.31)	
D	Width of parallel key	mm (in)	3 (0.12)	3 (0.12)	
E	Shaft width with parallel key	mm (in)	9.2 (0.36)	9.2 (0.36)	
F	Length of parallel key	mm (in)	12 (0.47)	12 (0.47)	
G	Distance parallel key to shaft end	mm (in)	4 (0.16)	4 (0.16)	
H	Female thread of shaft		DIN 332 DS M3 x 9	DIN 332 DS M3 x 9	
	Parallel key		DIN 6885-A3x3x12	DIN 6885-A3x3x12	

Dimensions BSH055

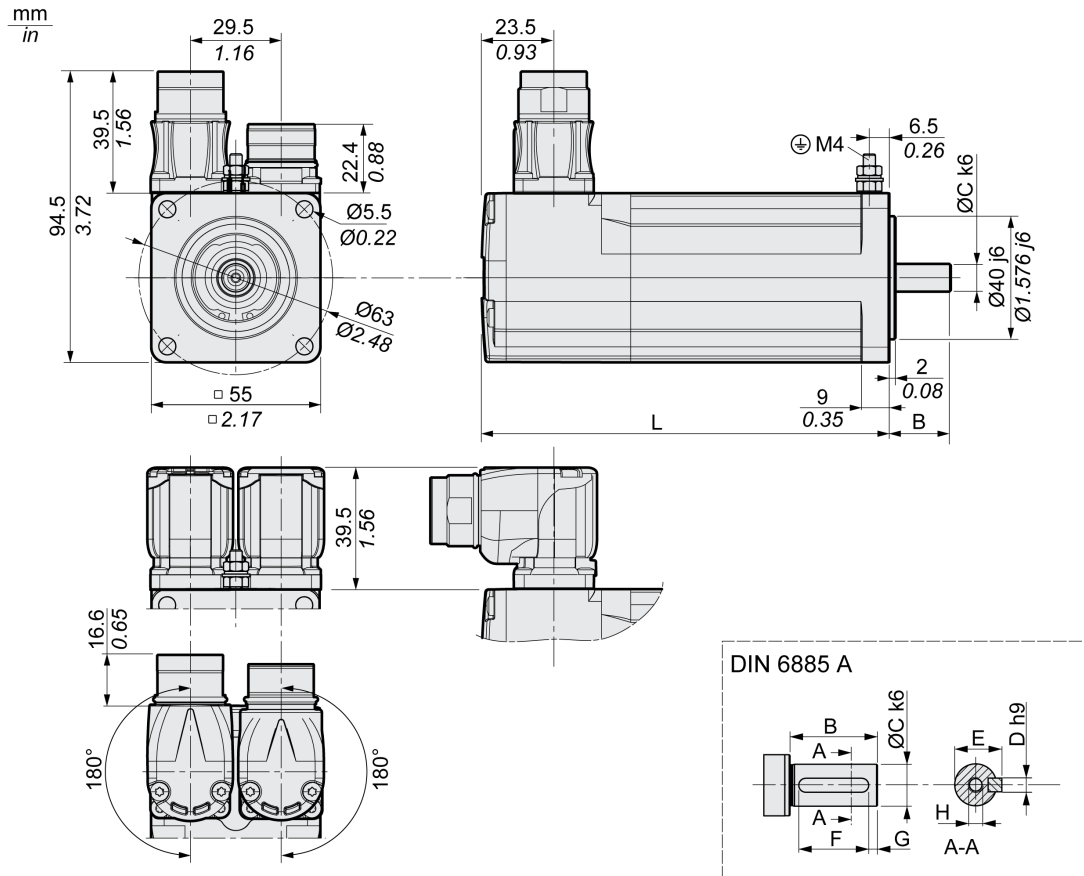

BSH...			0551	0552	0553
L	Length without holding brake	mm (in)	132.5 (5.22)	154.4 (6.08)	176.5 (6.95)
L	Length with holding brake	mm (in)	159 (6.26)	181 (7.13)	203 (7.99)
B	Shaft length	mm (in)	20 (0.79)	20 (0.79)	20 (0.79)
C	Shaft diameter	mm (in)	9 (0.35)	9 (0.35)	9 (0.35)
D	Width of parallel key	mm (in)	3 (0.12)	3 (0.12)	3 (0.12)
E	Shaft width with parallel key	mm (in)	10.2 (0.4)	10.2 (0.4)	10.2 (0.4)
F	Length of parallel key	mm (in)	12 (0.47)	12 (0.47)	12 (0.47)
G	Distance parallel key to shaft end	mm (in)	4 (0.16)	4 (0.16)	4 (0.16)
H	Female thread of shaft		DIN 332-D M3	DIN 332-D M3	DIN 332-D M3
	Parallel key		DIN 6885-A3x3x12	DIN 6885-A3x3x12	DIN 6885-A3x3x12

Dimensions BSH070

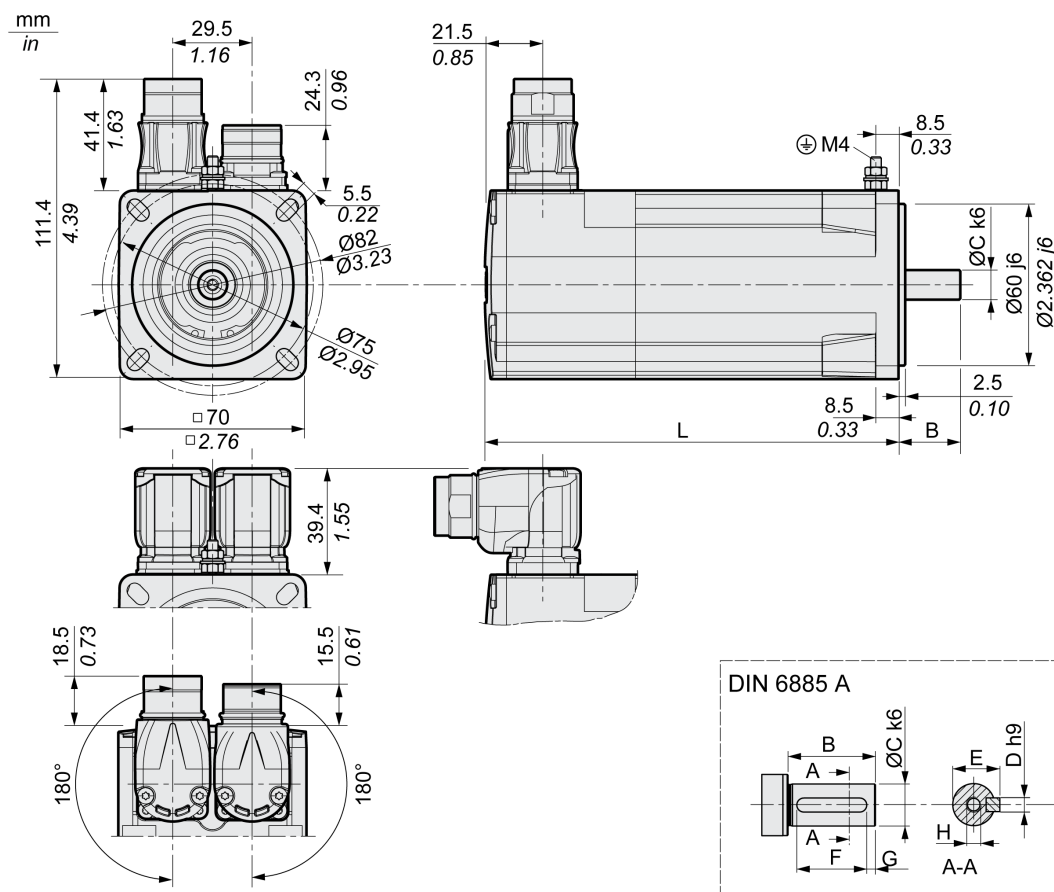

BSH...			0701	0702	0703
L	Length without holding brake	mm (in)	154 (6.06)	187 (7.36)	220 (8.66)
L	Length with holding brake	mm (in)	180 (7.09)	213 (8.39)	254 (10)
B	Shaft length	mm (in)	23 (0.91)	23 (0.91)	30 (1.18)
C	Shaft diameter	mm (in)	11 (0.43)	11 (0.43)	14 (0.55)
D	Width of parallel key	mm (in)	4 (0.16)	4 (0.16)	5 (0.2)
E	Shaft width with parallel key	mm (in)	12.5 (0.49)	12.5 (0.49)	16 (0.63)
F	Length of parallel key	mm (in)	18 (0.71)	18 (0.71)	20 (0.79)
G	Distance parallel key to shaft end	mm (in)	2.5 (0.1)	2.5 (0.1)	5 (0.2)
H	Female thread of shaft		DIN 332-D M4	DIN 332-D M4	DIN 332-D M5
	Parallel key		DIN 6885-A4x4x18	DIN 6885-A4x4x18	DIN 6885-A4x4x20

Dimensions BSH100

Hardware version ≥RS02:

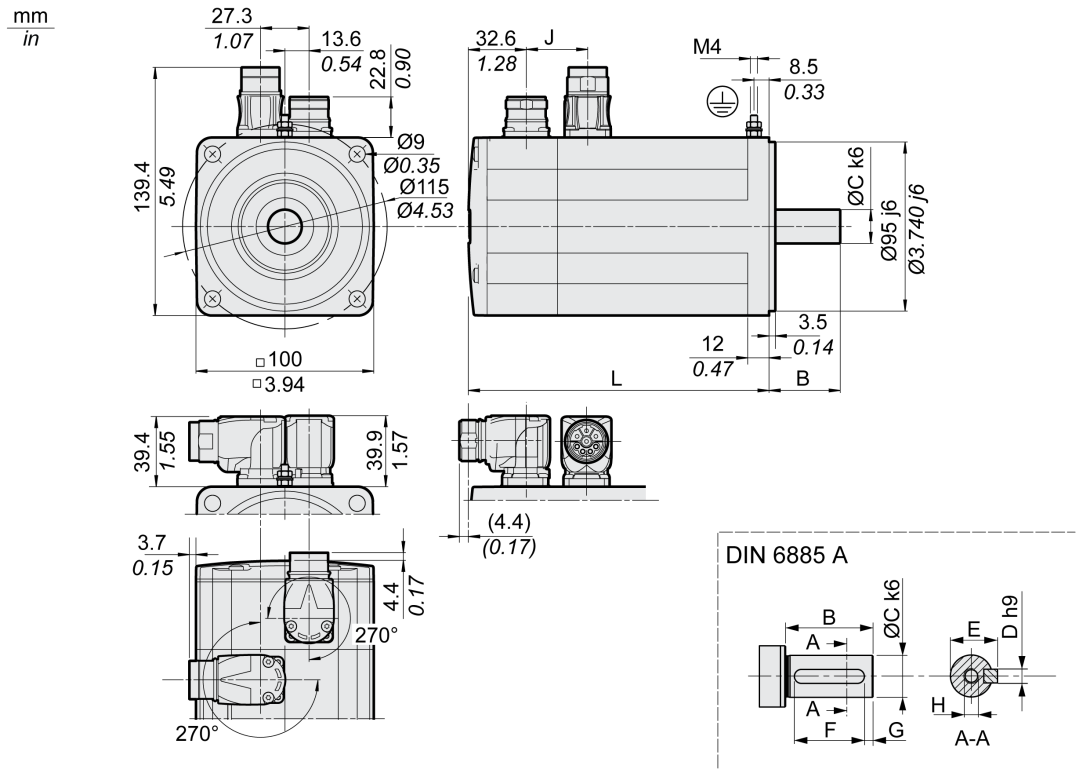

BSH...			1001	1002	1003	1004
L	Length without holding brake	mm (in)	168.5 (6.63)	204.5 (8.05)	240.5 (9.47)	276.5 (10.89)
L	Length with holding brake	mm (in)	199.5 (7.85)	235.5 (9.27)	271.5 (10.69)	307.5 (12.11)
B	Shaft length	mm (in)	40 (1.57)	40 (1.57)	40 (1.57)	50 (1.97)
C	Shaft diameter	mm (in)	19 (0.75)	19 (0.75)	19 (0.75)	24 (0.94)
D	Width of parallel key	mm (in)	6 (0.24)	6 (0.24)	6 (0.24)	8 (0.31)
E	Shaft width with parallel key	mm (in)	21.5 (0.85)	21.5 (0.85)	21.5 (0.85)	27 (1.06)
F	Length of parallel key	mm (in)	30 (1.18)	30 (1.18)	30 (1.18)	40 (1.57)
G	Distance parallel key to shaft end	mm (in)	5 (0.2)	5 (0.2)	5 (0.2)	5 (0.2)
H	Female thread of shaft		DIN 332-D M6	DIN 332-D M6	DIN 332-D M6	DIN 332-D M8
J	Connector distance without holding brake	mm (in)	34.5 (1.36)	34.5 (1.36)	34.5 (1.36)	34.5 (1.36)
J	Connector distance with holding brake	mm (in)	29.8 (1.17)	29.8 (1.17)	29.8 (1.17)	29.8 (1.17)
	Parallel key		DIN 6885-A6x6x30	DIN 6885-A6x6x30	DIN 6885-A6x6x30	DIN 6885-A8x7x40

Dimensions BSH100

Hardware version <RS02:

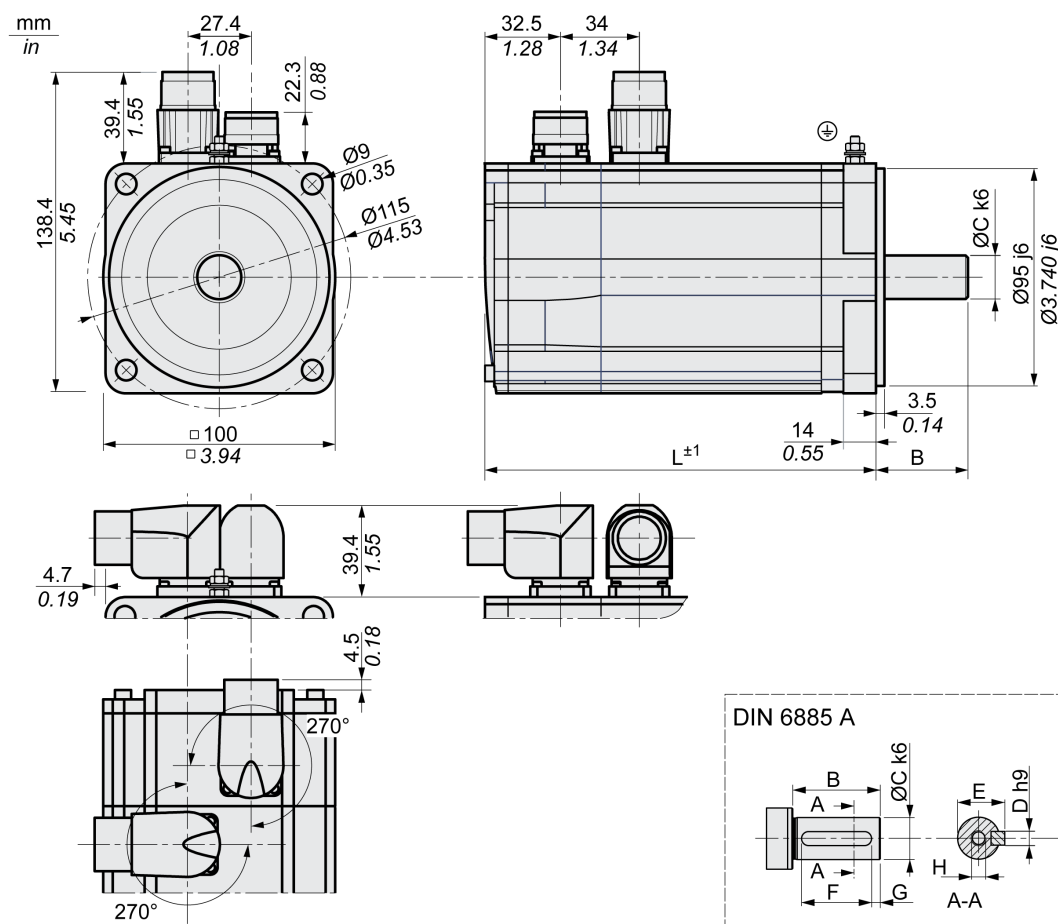

DIN 6885 A

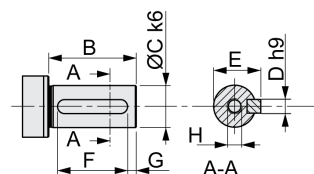

BSH...			1001	1002	1003	1004
L	Length without holding brake	mm (in)	168.5 (6.63)	204.5 (8.05)	240.5 (9.47)	276.5 (10.89)
L	Length with holding brake	mm (in)	199.5 (7.85)	235.5 (9.27)	271.5 (10.69)	307.5 (12.11)
B	Shaft length	mm (in)	40 (1.57)	40 (1.57)	40 (1.57)	50 (1.97)
C	Shaft diameter	mm (in)	19 (0.75)	19 (0.75)	19 (0.75)	24 (0.94)
D	Width of parallel key	mm (in)	6 (0.24)	6 (0.24)	6 (0.24)	8 (0.31)
E	Shaft width with parallel key	mm (in)	21.5 (0.85)	21.5 (0.85)	21.5 (0.85)	27 (1.06)
F	Length of parallel key	mm (in)	30 (1.18)	30 (1.18)	30 (1.18)	40 (1.57)
G	Distance parallel key to shaft end	mm (in)	5 (0.2)	5 (0.2)	5 (0.2)	5 (0.2)
H	Female thread of shaft		DIN 332-D M6	DIN 332-D M6	DIN 332-D M6	DIN 332-D M8
	Parallel key		DIN 6885-A6x6x30	DIN 6885-A6x6x30	DIN 6885-A6x6x30	DIN 6885-A8x7x40

Dimensions BSH140

Hardware version ≥RS02:

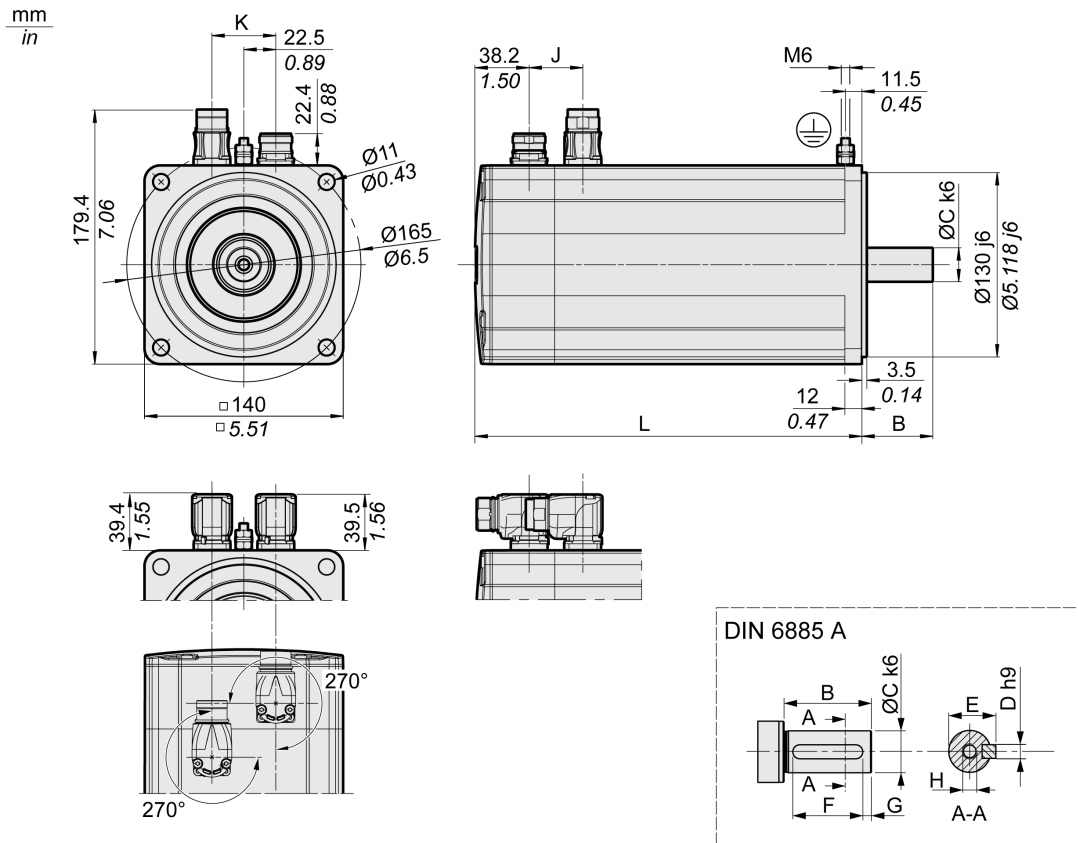

BSH...		1401	1402M, 1402P	1403M, 1403P	1404M	
L	Length without holding brake	mm (in)	217.5 (8.56)	272.5 (10.73)	327.5 (12.89)	382.5 (15.06)
L	Length with holding brake	mm (in)	255.5 (10.06)	310.5 (12.22)	365.5 (14.39)	420.5 (16.56)
B	Shaft length	mm (in)	50 (1.97)	50 (1.97)	50 (1.97)	50 (1.97)
C	Shaft diameter	mm (in)	24 (0.94)	24 (0.94)	24 (0.94)	24 (0.94)
D	Width of parallel key	mm (in)	8 (0.31)	8 (0.31)	8 (0.31)	8 (0.31)
E	Shaft width with parallel key	mm (in)	28 (1.1)	28 (1.1)	28 (1.1)	28 (1.1)
F	Length of parallel key	mm (in)	40 (1.57)	40 (1.57)	40 (1.57)	40 (1.57)
G	Distance parallel key to shaft end	mm (in)	5 (0.2)	5 (0.2)	5 (0.2)	5 (0.2)
H	Female thread of shaft		DIN 332-D M8	DIN 332-D M8	DIN 332-D M8	DIN 332-D M8
J	Connector distance 1 without holding brake	mm (in)	38 (1.5)	38 (1.5)	38 (1.5)	38 (1.5)
J	Connector distance 1 with holding brake	mm (in)	35 (1.38)	35 (1.38)	35 (1.38)	35 (1.38)

BSH...		1401	1402M, 1402P	1403M, 1403P	1404M	
K	Connector distance 2 without holding brake	mm (in)	45 (1.77)	45 (1.77)	45 (1.77)	45 (1.77)
K	Connector distance 2 with holding brake	mm (in)	38 (1.5)	38 (1.5)	38 (1.5)	38 (1.5)
	Parallel key		DIN 6885-A8x7x40	DIN 6885-A8x7x40	DIN 6885-A8x7x40	DIN 6885-A8x7x40

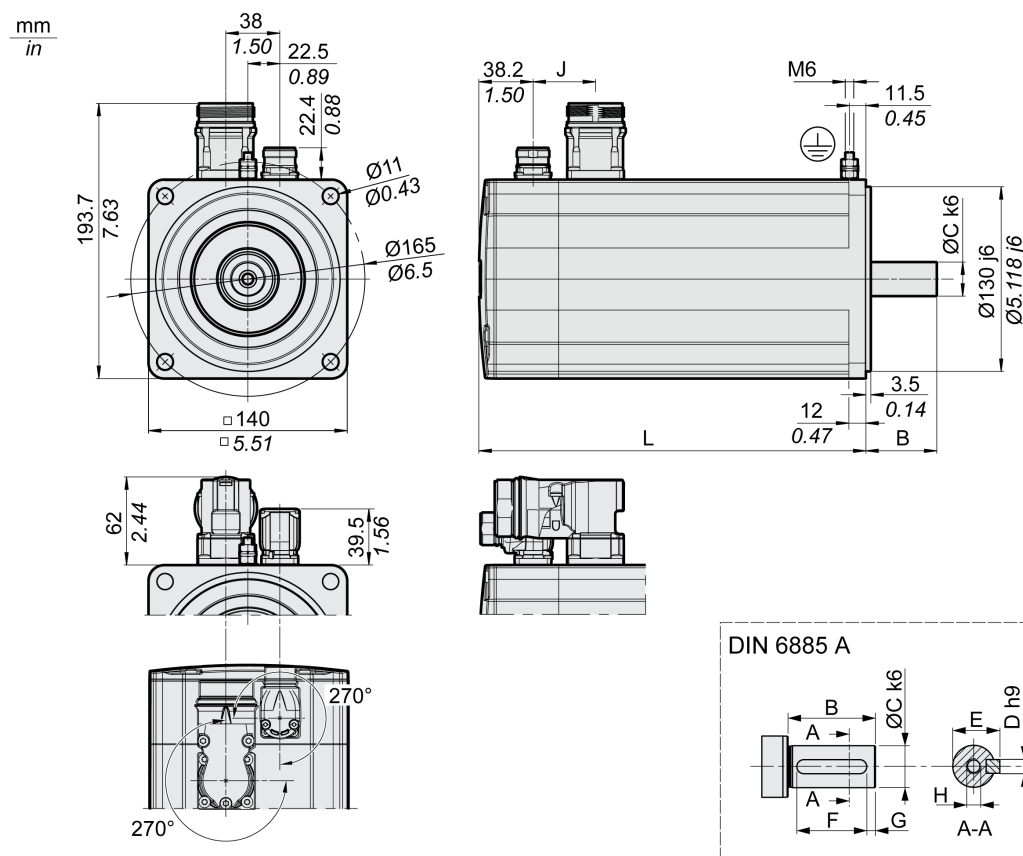

BSH...		1402T	1403T	1404P	
L	Length without holding brake	mm (in)	272.5 (10.73)	327.5 (12.89)	382.5 (15.06)
L	Length with holding brake	mm (in)	310.5 (12.22)	365.5 (14.39)	420.5 (16.56)
B	Shaft length	mm (in)	50 (1.97)	50 (1.97)	50 (1.97)
C	Shaft diameter	mm (in)	24 (0.94)	24 (0.94)	24 (0.94)
D	Width of parallel key	mm (in)	8 (0.31)	8 (0.31)	8 (0.31)
E	Shaft width with parallel key	mm (in)	28 (1.1)	28 (1.1)	28 (1.1)
F	Length of parallel key	mm (in)	40 (1.57)	40 (1.57)	40 (1.57)
G	Distance parallel key to shaft end	mm (in)	5 (0.2)	5 (0.2)	5 (0.2)
H	Female thread of shaft		DIN 332-D M8	DIN 332-D M8	DIN 332-D M8
J	Connector distance without holding brake	mm (in)	44 (1.73)	44 (1.73)	44 (1.73)
J	Connector distance with holding brake	mm (in)	35 (1.38)	35 (1.38)	35 (1.38)
	Parallel key		DIN 6885-A8x7x40	DIN 6885-A8x7x40	DIN 6885-A8x7x40

Dimensions BSH140

Hardware version <RS02:

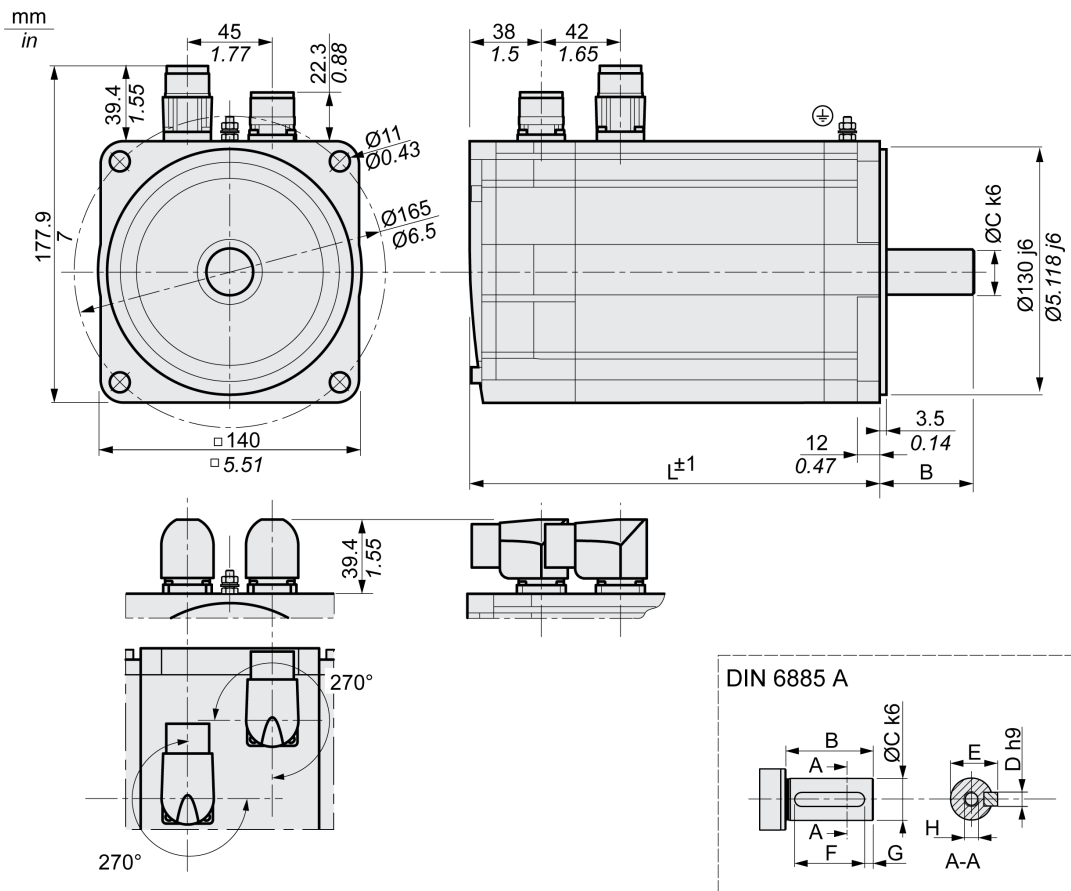

BSH...			1401	1402M, 1402P	1403M, 1403P	1404M
L	Length without holding brake	mm (in)	217.5 (8.56)	272.5 (10.73)	327.5 (12.89)	382.5 (15.06)
L	Length with holding brake	mm (in)	255.5 (10.06)	310.5 (12.22)	365.5 (14.39)	420.5 (16.56)
B	Shaft length	mm (in)	50 (1.97)	50 (1.97)	50 (1.97)	50 (1.97)
C	Shaft diameter	mm (in)	24 (0.94)	24 (0.94)	24 (0.94)	24 (0.94)
D	Width of parallel key	mm (in)	8 (0.31)	8 (0.31)	8 (0.31)	8 (0.31)
E	Shaft width with parallel key	mm (in)	28 (1.1)	28 (1.1)	28 (1.1)	28 (1.1)
F	Length of parallel key	mm (in)	40 (1.57)	40 (1.57)	40 (1.57)	40 (1.57)
G	Distance parallel key to shaft end	mm (in)	5 (0.2)	5 (0.2)	5 (0.2)	5 (0.2)
H	Female thread of shaft		DIN 332-D M8	DIN 332-D M8	DIN 332-D M8	DIN 332-D M8
	Parallel key		DIN 6885-A8x7x40	DIN 6885-A8x7x40	DIN 6885-A8x7x40	DIN 6885-A8x7x40

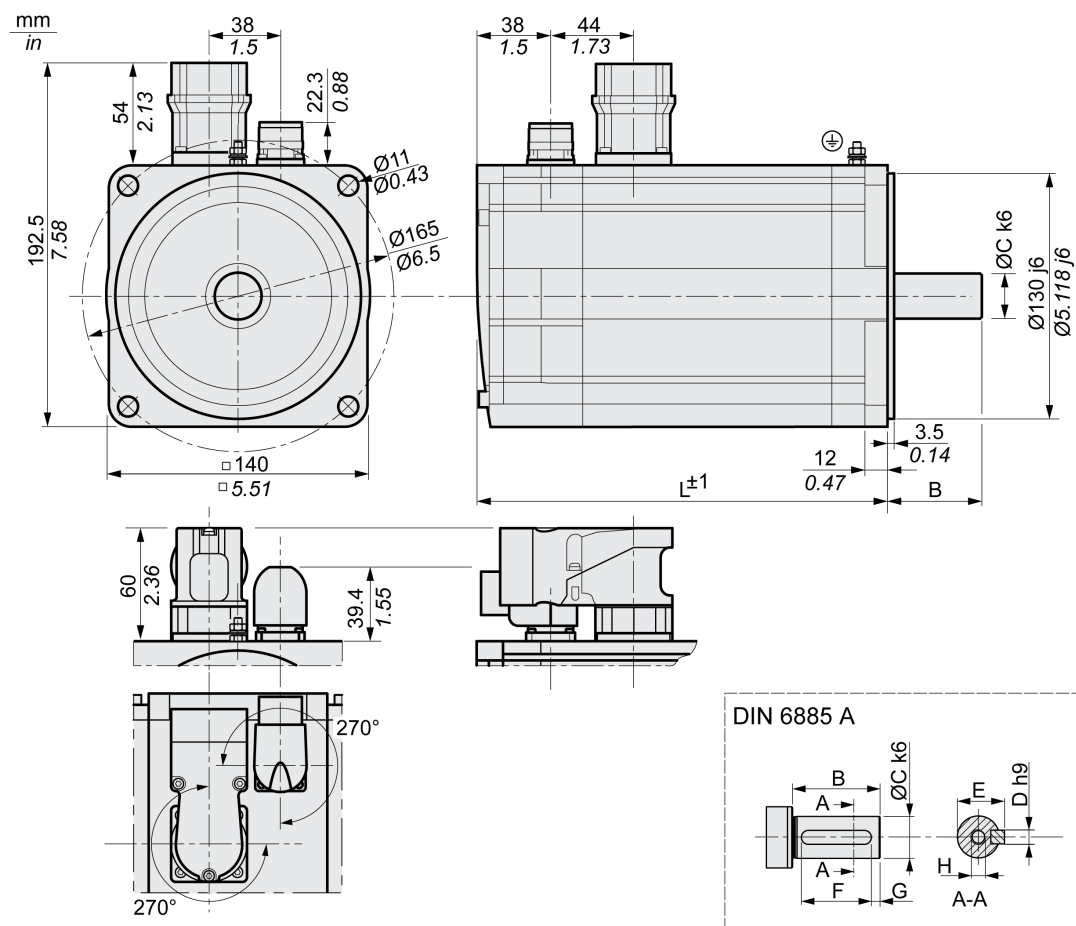

BSH...			1402T	1403T	1404P
L	Length without holding brake	mm (in)	272.5 (10.73)	327.5 (12.89)	382.5 (15.06)
L	Length with holding brake	mm (in)	310.5 (12.22)	365.5 (14.39)	420.5 (16.56)
B	Shaft length	mm (in)	50 (1.97)	50 (1.97)	50 (1.97)
C	Shaft diameter	mm (in)	24 (0.94)	24 (0.94)	24 (0.94)
D	Width of parallel key	mm (in)	8 (0.31)	8 (0.31)	8 (0.31)
E	Shaft width with parallel key	mm (in)	28 (1.1)	28 (1.1)	28 (1.1)
F	Length of parallel key	mm (in)	40 (1.57)	40 (1.57)	40 (1.57)
G	Distance parallel key to shaft end	mm (in)	5 (0.2)	5 (0.2)	5 (0.2)
H	Female thread of shaft		DIN 332-D M8	DIN 332-D M8	DIN 332-D M8
	Parallel key		DIN 6885-A8x7x40	DIN 6885-A8x7x40	DIN 6885-A8x7x40

Dimensions BSH205

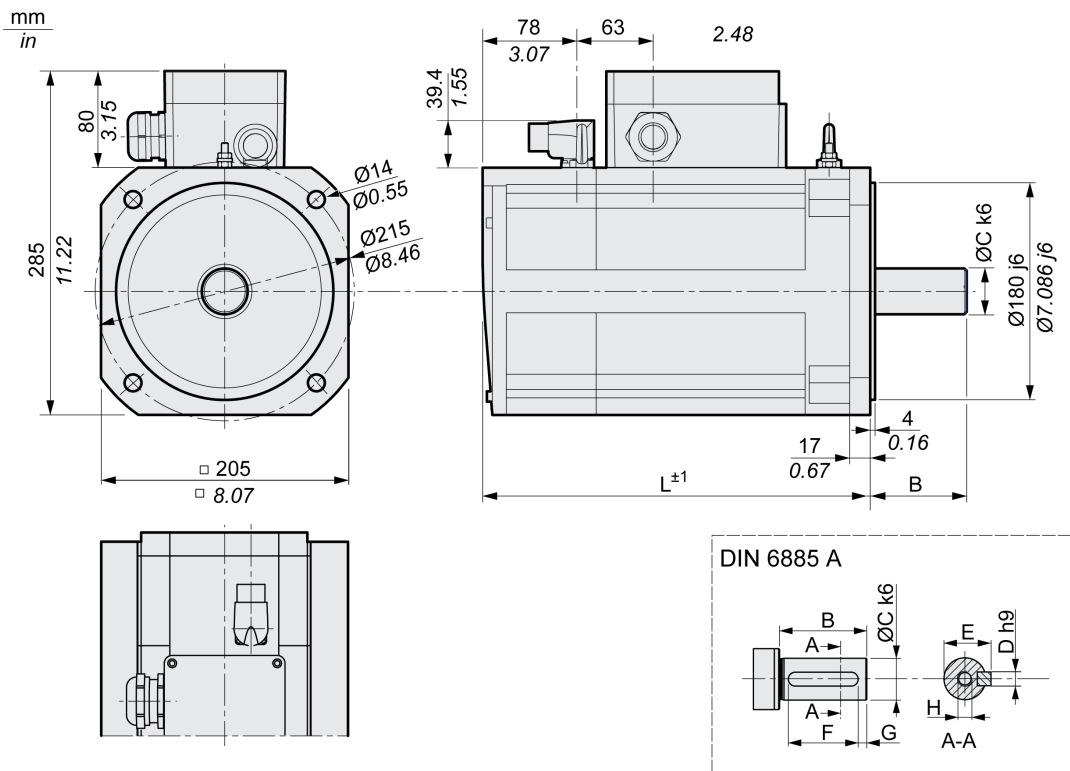
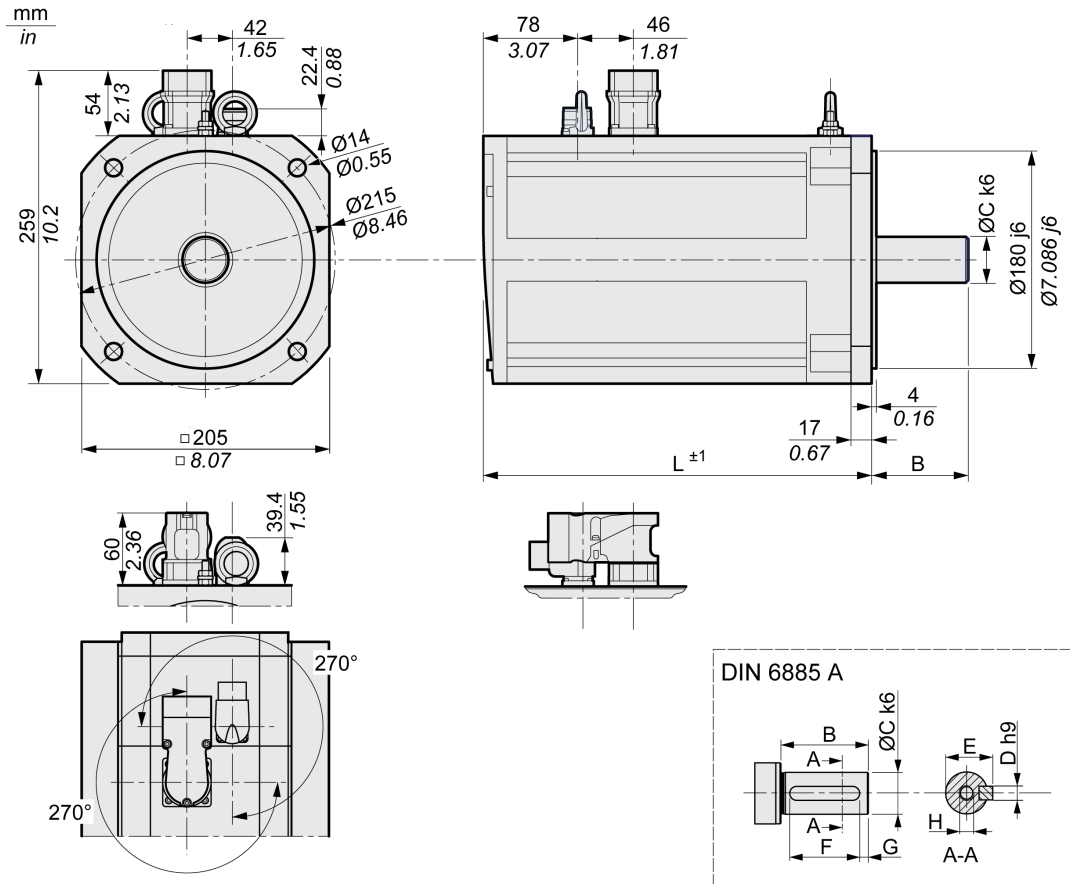

BSH...			2051	2052	2053
L	Length without holding brake	mm (in)	321 (12.64)	405 (15.94)	489 (19.25)
L	Length with holding brake	mm (in)	370.5 (14.59)	454.5 (17.89)	538.5 (21.2)
B	Shaft length	mm (in)	80 (3.15)	80 (3.15)	80 (3.15)
C	Shaft diameter	mm (in)	38 (1.5)	38 (1.5)	38 (1.5)
D	Width of parallel key	mm (in)	10 (0.39)	10 (0.39)	10 (0.39)
E	Shaft width with parallel key	mm (in)	43 (1.69)	43 (1.69)	43 (1.69)
F	Length of parallel key	mm (in)	70 (2.76)	70 (2.76)	70 (2.76)
G	Distance parallel key to shaft end	mm (in)	5 (0.2)	5 (0.2)	5 (0.2)
H	Female thread of shaft		DIN 332-D M12	DIN 332-D M12	DIN 332-D M12
	Parallel key		DIN 6885-A10x8x70	DIN 6885-A10x8x70	DIN 6885-A10x8x70

Shaft-Specific Data

If the maximum permissible forces at the motor shaft are exceeded, this will result in premature wear of the bearing or shaft breakage.

⚠ WARNING
UNINTENDED EQUIPMENT OPERATION DUE TO MECHANICAL DAMAGE TO THE MOTOR
<ul style="list-style-type: none"> ● Do not exceed the maximum permissible axial and radial forces at the motor shaft. ● Protect the motor shaft from impact. ● Do not exceed the maximum permissible axial force when pressing components onto the motor shaft.
Failure to follow these instructions can result in death, serious injury, or equipment damage.

Force for Pressing On

The force applied during pressing on must not exceed the maximum permissible axial force. Applying assembly paste to the shaft and the component to be mounted reduces friction and mechanical impact on the surfaces.

If the shaft has a thread, use it to press on the component to be mounted. This way there is no axial force acting on the rolling bearing.

It is also possible to shrink-fit, clamp or glue the component to be mounted.

The following table shows the maximum permissible axial force F_A at standstill.

BSH...		040	055	070	100	140	205
Maximum axial force F_A at standstill	N (lbf)	20 (4.5)	40 (9)	80 (18)	160 (36)	300 (65)	740 (165)

Shaft Load

The following conditions apply:

- The permissible force applied during pressing on must not be exceeded
- Radial and axial limit loads must not be applied simultaneously
- Nominal bearing service life in operating hours at a probability of failure of 10% ($L_{10h} = 20000$ hours)
- Mean speed of rotation $n = 4000$ rpm
- Ambient temperature = 40 °C (104 °F)
- Peak torque = Duty types S3 - S8, 10% duty cycle
- Nominal torque = Duty type S1, 100% duty cycle

Shaft load

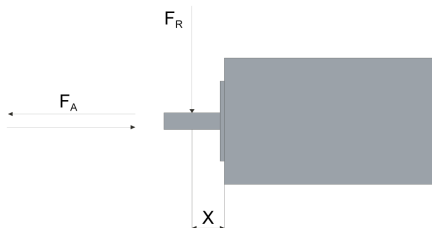

The point of application of the forces depends on the motor size:

BSH...		040	055	0701, 0702	0703	1001, 1002, 1003	1004, 140	205
Value for X	mm (in)	12.5 (0.49)	10 (0.39)	11.5 (0.45)	15 (0.59)	20 (0.76)	25 (0.98)	40 (1.57)

The following tables show the maximum radial shaft load F_R :

BSH...		0401	0402	0551	0552	0553	0701	0702	0703	1001	1002
1000 rpm	N (lbf)	130 (29)	145 (32)	340 (76)	370 (83)	390 (88)	660 (148)	710 (160)	730 (164)	900 (202)	990 (223)
2000 rpm	N (lbf)	105 (24)	115 (26)	270 (61)	290 (65)	310 (70)	520 (117)	560 (126)	580 (130)	720 (162)	790 (178)
3000 rpm	N (lbf)	90 (20)	100 (22)	240 (54)	260 (58)	270 (61)	460 (103)	490 (110)	510 (115)	630 (142)	690 (155)
4000 rpm	N (lbf)	85 (19)	90 (20)	220 (49)	230 (52)	240 (54)	410 (92)	450 (101)	460 (103)	570 (128)	620 (139)
5000 rpm	N (lbf)	76 (17)	85 (19)	200 (45)	220 (49)	230 (52)	380 (85)	410 (92)	430 (97)	530 (119)	-
6000 rpm	N (lbf)	72 (16)	80 (80)	190 (43)	200 (45)	210 (47)	360 (81)	390 (88)	400 (90)	-	-
7000 rpm	N (lbf)	68 (15)	76 (17)	180 (40)	190 (43)	200 (45)	-	-	-	-	-
8000 rpm	N (lbf)	65 (15)	72 (16)	170 (38)	190 (43)	190 (43)	-	-	-	-	-
9000 rpm	N (lbf)	63 (14)	70 (16)	-	-	-	-	-	-	-	-
10000 rpm	N (lbf)	60 (13)	67 (15)	-	-	-	-	-	-	-	-

BSH...		1003	1004	1401	1402	1403	1404	2051	2052	2053
1000 rpm	N (lbf)	1050 (236)	1070 (241)	1930 (434)	2240 (504)	2420 (544)	2660 (598)	3730 (839)	4200 (944)	4500 (1012)
2000 rpm	N (lbf)	830 (187)	850 (191)	1530 (344)	1780 (400)	1920 (432)	2110 (474)	2960 (665)	3330 (749)	3570 (803)
3000 rpm	N (lbf)	730 (164)	740 (166)	1340 (301)	1550 (348)	1670 (375)	1840 (414)	2580 (580)	2910 (654)	3120 (701)
4000 rpm	N (lbf)	660 (148)	-	-	-	-	-	-	-	-

The following tables show the maximum axial shaft load F_A :

BSH...		0401	0402	0551	0552	0553	0701	0702	0703	1001	1002
1000 rpm	N (lbf)	26 (6)	29 (7)	68 (15)	74 (17)	78 (18)	132 (30)	142 (32)	146 (33)	180 (40)	198 (45)
2000 rpm	N (lbf)	21 (5)	23 (5)	54 (12)	58 (13)	62 (14)	104 (23)	112 (25)	116 (26)	144 (32)	158 (36)
3000 rpm	N (lbf)	18 (4)	20 (4)	48 (11)	52 (12)	54 (12)	92 (21)	98 (22)	102 (23)	126 (28)	138 (31)
4000 rpm	N (lbf)	17 (4)	18 (4)	44 (10)	46 (10)	48 (11)	82 (18)	90 (20)	92 (21)	114 (26)	124 (28)
5000 rpm	N (lbf)	16 (4)	17 (4)	40 (9)	44 (10)	46 (10)	76 (17)	82 (18)	86 (19)	106 (24)	-
6000 rpm	N (lbf)	15 (3)	16 (4)	38 (9)	40 (9)	42 (9)	72 (16)	78 (18)	80 (18)	-	-
7000 rpm	N (lbf)	14 (3)	15 (3)	36 (8)	38 (9)	40 (9)	-	-	-	-	-
8000 rpm	N (lbf)	13 (3)	14 (3)	34 (8)	38 (9)	38 (9)	-	-	-	-	-
9000 rpm	N (lbf)	12 (3)	13 (3)	-	-	-	-	-	-	-	-
10000 rpm	N (lbf)	11 (2)	12 (3)	-	-	-	-	-	-	-	-

BSH...		1003	1004	1401	1402	1403	1404	2051	2052	2053
1000 rpm	N (lbf)	210 (47)	214 (48)	386 (87)	448 (101)	484 (109)	532 (120)	746 (168)	840 (189)	900 (202)
2000 rpm	N (lbf)	166 (37)	170 (38)	306 (69)	356 (80)	384 (86)	422 (95)	592 (133)	666 (150)	714 (161)
3000 rpm	N (lbf)	146 (33)	148 (33)	268 (60)	310 (70)	334 (75)	368 (83)	516 (116)	582 (131)	624 (140)
4000 rpm	N (lbf)	132 (30)	-	-	-	-	-	-	-	-

Motor-Specific Data

BSH040

BSH...		0401	0402
Winding		P	P
Technical data - general¹⁾			
Continuous stall torque $M_0^{2)}$	Nm	0.21	0.39
Peak torque M_{max}	Nm	0.75	1.50
Number of pole pairs		5	
With supply voltage $U_n = 115$ Vac			
Nominal speed of rotation n_N	rpm	2000	2000
Nominal torque M_N	Nm	0.20	0.38
Nominal current I_N	A_{rms}	1.03	1.45
Nominal power P_N	kW	0.042	0.078
With supply voltage $U_n = 230$ Vac			
Nominal speed of rotation n_N	rpm	4000	4000
Nominal torque M_N	Nm	0.19	0.37
Nominal current I_N	A_{rms}	1.01	1.42
Nominal power P_N	kW	0.080	0.152
With supply voltage $U_n = 400$ Vac			
Nominal speed of rotation n_N	rpm	9000	9000
Nominal torque M_N	Nm	0.18	0.31
Nominal current I_N	A_{rms}	1.02	1.27
Nominal power P_N	kW	0.170	0.292
With supply voltage $U_n = 480$ Vac			
Nominal speed of rotation n_N	rpm	9000	9000
Nominal torque M_N	Nm	0.175	0.290
Nominal current I_N	A_{rms}	1.04	1.26
Nominal power P_N	kW	0.165	0.275
<p>1) Conditions for performance data: Mounted to aluminum plate 185 mm (7.28 in) x 185 mm (7.28 in) x 8 mm (0.31 in).</p> <p>2) M_0 = Continuous stall torque at 20 rpm and 100% duty cycle; at speeds of rotation less than 20 rpm the continuous stall torque is reduced to 87%.</p>			

BSH...		0401	0402
Winding		P	P
Technical data - electrical			
Maximum winding voltage U_{max}	Vac	480	480
Maximum winding voltage U_{max}	Vdc	680	680
Maximum voltage to ground	Vac	280	280
Maximum current I_{max}	A_{rms}	4.5	7.2
Continuous stall current I_0	A_{rms}	1.12	1.50
Voltage constant $k_{E-U^{-1}}$	V_{rms}	13.6	18.0
Torque constant k_t	Nm/A	0.190	0.260
1) RMS value at 1000 rpm and 20°C (68 °F).			

BSH...		0401		0402	
Winding		P		P	
Winding resistance R_{20U-V}	Ω	17.2		11.6	
Winding inductance L_{qU-V}	mH	14.6		12.8	
Winding inductance L_{dU-V}	mH	13.2		11.6	
Technical data - mechanical					
Maximum permissible speed of rotation n_{max}	rpm	10000			
Rotor inertia without holding brake J_M	kgcm ²	0.0232		0.0419	
Rotor inertia with holding brake J_M	kgcm ²	0.0400		0.0588	
Mass without holding brake m	kg	0.43		0.57	
Mass with holding brake m	kg	0.58		0.72	
Technical data - thermal					
Thermal time constant t_{th}	min	8		10	
1) RMS value at 1000 rpm and 20°C (68 °F).					

BSH055

BSH...		0551		0552			0553		
Winding		P	T	M	P	T	M	P	T
Technical data - general¹⁾									
Continuous stall torque $M_0^{2)}$	Nm	0.5		0.8			1.2		
Peak torque M_{max}	Nm	1.5		2.5			3.5		
Number of pole pairs		3							
With supply voltage $U_n = 115$ Vac									
Nominal speed of rotation n_N	rpm	2000	4000	1000	2000	4000	1000	2000	4000
Nominal torque M_N	Nm	0.50	0.50	0.77	0.77	0.75	1.14	1.13	1.10
Nominal current I_N	A_{rms}	0.70	1.24	0.60	1.18	2.10	0.84	1.60	2.80
Nominal power P_N	kW	0.10	0.21	0.08	0.16	0.31	0.12	0.24	0.46
With supply voltage $U_n = 230$ Vac									
Nominal speed of rotation n_N	rpm	8000	8000	2000	4000	8000	2000	4000	8000
Nominal torque M_N	Nm	0.50	0.48	0.77	0.75	0.72	1.13	1.10	1.05
Nominal current I_N	A_{rms}	0.68	1.1	0.60	1.15	2.00	0.79	1.52	2.50
Nominal power P_N	kW	0.21	0.40	0.16	0.31	0.60	0.24	0.46	0.88
With supply voltage $U_n = 400$ Vac									
Nominal speed of rotation n_N	rpm	8000	8000	4000	8000	8000	4000	8000	8000
Nominal torque M_N	Nm	0.48	0.48	0.75	0.72	0.72	1.10	1.05	1.05
Nominal current I_N	A_{rms}	0.62	1.10	0.60	1.10	2.00	0.700	1.35	2.50
Nominal power P_N	kW	0.40	0.40	0.31	0.60	0.60	0.46	0.88	0.88
With supply voltage $U_n = 480$ Vac									
Nominal speed of rotation n_N	rpm	9000	9000	4800	9000	9000	4800	9000	9000
Nominal torque M_N	Nm	0.47	0.47	0.75	0.71	0.71	1.1	1.03	1.03
Nominal current I_N	A_{rms}	0.60	1.07	0.60	1.09	1.98	0.67	1.31	2.45
Nominal power P_N	kW	0.44	0.44	0.38	0.67	0.67	0.55	0.97	0.97
1) Conditions for performance data: Mounted to steel plate 175 mm (6.89 in) x 175 mm (6.89 in) x 10 mm (0.39 in).									
2) M_0 = Continuous stall torque at 20 rpm and 100% duty cycle; at speeds of rotation less than 20 rpm the continuous stall torque is reduced to 87%.									

BSH...		0551		0552			0553		
Winding		P	T	M	P	T	M	P	T
Technical data - electrical									
Maximum winding voltage U_{max}	Vac	480	480	480	480	480	480	480	480
Maximum winding voltage U_{max}	Vdc	680	680	680	680	680	680	680	680
Maximum voltage to ground	Vac	280	280	280	280	280	280	280	280
Maximum current I_{max}	A_{rms}	2.90	5.40	2.60	4.80	8.80	3.40	6.50	11.90
Continuous stall current I_0	A_{rms}	0.73	1.40	0.60	1.20	2.20	0.90	1.70	3.10
Voltage constant $k_{E-u-v^{1)}$	V_{rms}	40.00	22.00	74.00	40.00	22.00	79.00	41.00	22.00
Torque constant k_t	Nm/A	0.68	0.36	1.33	0.70	0.36	1.33	0.70	0.39
Winding resistance R_{20u-v}	Ω	41.80	12.20	55.50	17.40	4.60	38.40	10.40	3.10
Winding inductance L_{q-u-v}	mH	74.3	21.70	125.80	36.40	10.90	96.10	26.00	7.80
Winding inductance L_{d-u-v}	mH	68.84	20.10	118.50	34.28	10.30	88.50	23.96	7.10
Technical data - mechanical - with hardware version \geqRS02									
Maximum permissible speed of rotation n_{max}	rpm	9000							
Rotor inertia without holding brake J_M	kgcm ²	0.057		0.093			0.130		
Rotor inertia with holding brake J_M	kgcm ²	0.079		0.115			0.152		
Mass without holding brake m	kg	1.20		1.50			1.70		
Mass with holding brake m	kg	1.30		1.60			1.80		
Technical data - mechanical - with hardware version $<$RS02									
Maximum permissible speed of rotation n_{max}	rpm	9000							
Rotor inertia without holding brake J_M	kgcm ²	0.057		0.093			0.130		
Rotor inertia with holding brake J_M	kgcm ²	0.080		0.117			0.155		
Mass without holding brake m	kg	1.20		1.30			1.80		
Mass with holding brake m	kg	1.30		1.60			2.10		
Technical data - thermal									
Thermal time constant t_{th}	min	21		26			33		
Response threshold temperature sensor (PTC) T_{TK}	$^{\circ}C$ $(^{\circ}F)$	130 (266)							
1) RMS value at 1000 rpm and 20 $^{\circ}C$ (68 $^{\circ}F$).									

BSH070

BSH...	0701			0702			0703			
Winding	M	P	T	M	P	T	M	P	T	
Technical data - general¹⁾										
Continuous stall torque $M_0^{2)}$	Nm	1.4		2.2		3.1				
Peak torque M_{max}	Nm	3.5		7.6		11.3				
Number of pole pairs		3								
With supply voltage $U_n = 115$ Vac										
Nominal speed of rotation n_N	rpm	750	1500	3000	750	1500	3000	750	1500	3000
Nominal torque M_N	Nm	1.40	1.40	1.40	2.20	2.15	2.10	3.05	2.95	2.80
Nominal current I_N	A_{rms}	0.98	1.76	3.00	1.50	2.90	4.80	2.10	3.90	6.30
Nominal power P_N	kW	0.11	0.22	0.44	0.17	0.34	0.66	0.24	0.46	0.88
With supply voltage $U_n = 230$ Vac										
Nominal speed of rotation n_N	rpm	1500	3000	6000	1500	3000	6000	1500	3000	6000
Nominal torque M_N	Nm	1.40	1.40	1.30	2.15	2.10	1.90	2.95	2.80	2.30
Nominal current I_N	A_{rms}	0.95	1.72	2.80	1.50	2.80	4.40	2.00	3.70	5.20
Nominal power P_N	kW	0.22	0.44	0.82	0.34	0.66	1.19	0.46	0.88	1.45
With supply voltage $U_n = 400$ Vac										
Nominal speed of rotation n_N	rpm	3000	6000	6000	3000	6000	6000	3000	6000	6000
Nominal torque M_N	Nm	1.40	1.30	1.30	2.10	1.90	1.90	2.80	2.30	2.30
Nominal current I_N	A_{rms}	0.90	1.60	2.80	1.50	2.60	4.40	1.90	3.00	5.20
Nominal power P_N	kW	0.44	0.82	0.82	0.66	1.19	1.19	0.88	1.45	1.45
With supply voltage $U_n = 480$ Vac										
Nominal speed of rotation n_N	rpm	3600	7200	7200	3600	7200	7200	3600	7200	7200
Nominal torque M_N	Nm	1.35	1.26	1.26	2.07	1.80	1.80	2.72	2.05	2.05
Nominal current I_N	A_{rms}	0.88	1.54	2.70	1.50	2.50	4.20	1.85	2.65	4.60
Nominal power P_N	kW	0.50	0.95	0.95	0.78	1.36	1.36	1.03	1.55	1.55
<p>1) Conditions for performance data: Mounted to steel plate (2.5 x flange dimension)² area, 10 mm (0.39 in) thickness, centered hole.</p> <p>2) M_0 = Continuous stall torque at 20 rpm and 100% duty cycle; at speeds of rotation less than 20 rpm the continuous stall torque is reduced to 87%.</p>										

BSH...	0701			0702			0703			
Winding	M	P	T	M	P	T	M	P	T	
Technical data - electrical										
Maximum winding voltage U_{max}	Vac	480	480	480	480	480	480	480	480	480
Maximum winding voltage U_{max}	Vdc	680	680	680	680	680	680	680	680	680
Maximum voltage to ground	Vac	280	280	280	280	280	280	280	280	280
Maximum current I_{max}	A_{rms}	3.10	5.70	10.10	6.00	11.80	19.90	8.70	17.00	29.20
Continuous stall current I_0	A_{rms}	1.00	1.80	3.20	1.50	2.90	4.90	2.10	4.10	7.00
Voltage constant $k_E u-v^1)$	V_{rms}	85.00	46.00	26.00	95.90	48.00	28.00	95.00	49.00	29.00
Torque constant k_t	Nm/A	1.40	0.80	0.44	1.47	0.77	0.45	1.48	0.78	0.44
Winding resistance R_{20u-v}	Ω	35.40	10.40	3.30	16.40	4.20	1.50	10.70	2.70	0.97
Winding inductance $L_{q u-v}$	mH	144.80	42.60	13.50	83.10	21.30	7.50	55.30	14.60	4.90
Winding inductance $L_d u-v$	mH	120.00	35.30	11.20	65.20	16.70	5.90	43.10	11.40	3.90
1) RMS value at 1000 rpm and 20 °C (68 °F).										

BSH...	0701			0702			0703		
Winding	M	P	T	M	P	T	M	P	T
Technical data - mechanical - with hardware version ≥RS02									
Maximum permissible speed of rotation n_{max}	rpm	8000							
Rotor inertia without holding brake J_M	kgcm ²	0.205			0.351			0.503	
Rotor inertia with holding brake J_M	kgcm ²	0.318			0.464			0.616	
Mass without holding brake m	kg	1.90			2.80			3.40	
Mass with holding brake m	kg	2.10			3.00			3.50	
Technical data - mechanical - with hardware version <RS02									
Maximum permissible speed of rotation n_{max}	rpm	8000							
Rotor inertia without holding brake J_M	kgcm ²	0.205			0.351			0.503	
Rotor inertia with holding brake J_M	kgcm ²	0.322			0.482			0.807	
Mass without holding brake m	kg	2.20			2.90			3.50	
Mass with holding brake m	kg	2.40			3.00			4.10	
Technical data - thermal									
Thermal time constant t_{th}	min	35			38			51	
Response threshold temperature sensor (PTC) T_{TK}	°C (°F)	130 (266)							
1) RMS value at 1000 rpm and 20 °C (68 °F).									

BSH100

BSH...	1001			1002			
Winding	M	P	T	M	P	T	
Technical data - general¹⁾							
Continuous stall torque $M_0^{2)}$	Nm	3.3			5.8		
Peak torque M_{max}	Nm	9.6			18.3		
Number of pole pairs		4					
With supply voltage $U_n = 115$ Vac							
Nominal speed of rotation n_N	rpm	625	1250	2500	500	1000	2000
Nominal torque M_N	Nm	3.20	3.15	3.00	5.70	5.50	5.20
Nominal current I_N	A_{rms}	1.75	3.50	6.60	2.45	4.55	8.85
Nominal power P_N	kW	0.21	0.41	0.79	0.30	0.58	1.09
With supply voltage $U_n = 230$ Vac							
Nominal speed of rotation n_N	rpm	1250	2500	5000	1000	2000	4000
Nominal torque M_N	Nm	3.15	3.00	2.70	5.50	5.20	4.60
Nominal current I_N	A_{rms}	1.70	3.20	5.90	2.40	4.30	7.90
Nominal power P_N	kW	0.41	0.79	1.41	0.58	1.09	1.93
With supply voltage $U_n = 400$ Vac							
Nominal speed of rotation n_N	rpm	2500	5000	5000	2000	4000	4000
Nominal torque M_N	Nm	3.00	2.70	2.70	5.20	4.60	4.60
Nominal current I_N	A_{rms}	1.60	2.80	5.90	2.30	3.80	7.90
Nominal power P_N	kW	0.79	1.41	1.41	1.09	1.93	1.93
1) Conditions for performance data: Mounted to steel plate (2.5 x flange dimension) ²⁾ area, 10 mm (0.39 in) thickness, centered hole.							
2) M_0 = Continuous stall torque at 20 rpm and 100% duty cycle; at speeds of rotation less than 20 rpm the continuous stall torque is reduced to 87%.							

BSH...	1001			1002			
Winding	M	P	T	M	P	T	
Technical data - general¹⁾							
With supply voltage $U_n = 480$ Vac							
Nominal speed of rotation n_N	rpm	3000	6000	6000	2400	4800	4800
Nominal torque M_N	Nm	2.95	2.60	2.60	5.10	4.40	4.40
Nominal current I_N	A_{rms}	1.60	2.60	5.60	2.25	3.60	7.50
Nominal power P_N	kW	0.93	1.63	1.63	1.28	2.21	2.21
1) Conditions for performance data: Mounted to steel plate (2.5 x flange dimension) ² area, 10 mm (0.39 in) thickness, centered hole. 2) M_0 = Continuous stall torque at 20 rpm and 100% duty cycle; at speeds of rotation less than 20 rpm the continuous stall torque is reduced to 87%.							

BSH...	1001			1002			
Winding	M	P	T	M	P	T	
Technical data - electrical							
Maximum winding voltage U_{max}	Vac	480	480	480	480	480	
Maximum winding voltage U_{max}	Vdc	680	680	680	680	680	
Maximum voltage to ground	Vac	280	280	280	280	280	
Maximum current I_{max}	A_{rms}	6.30	12.00	25.10	9.00	17.10	35.40
Continuous stall current I_0	A_{rms}	1.80	3.50	7.30	2.50	4.80	9.90
Voltage constant $k_E u-v^1)$	V_{rms}	115.00	60.00	29.00	146.00	77.00	37.00
Torque constant k_t	Nm/A	1.83	0.89	0.45	2.32	1.21	0.59
Winding resistance R_{20u-v}	Ω	13.90	3.80	0.87	8.60	2.40	0.56
Winding inductance L_{qu-v}	mH	69.40	19.00	4.30	48.60	13.50	3.10
Winding inductance L_{d-u-v}	mH	59.50	16.30	3.70	43.20	12.00	2.80
Technical data - mechanical - with hardware version \geqRS02							
Maximum permissible speed of rotation n_{max}	rpm	6000					
Rotor inertia without holding brake J_M	kgcm ²	1.100			1.909		
Rotor inertia with holding brake J_M	kgcm ²	1.613			2.422		
Mass without holding brake m	kg	4.40			6.00		
Mass with holding brake m	kg	4.90			6.50		
Technical data - mechanical - with hardware version $<$RS02							
Maximum permissible speed of rotation n_{max}	rpm	6000					
Rotor inertia without holding brake J_M	kgcm ²	1.100			1.909		
Rotor inertia with holding brake J_M	kgcm ²	2.018			2.928		
Mass without holding brake m	kg	4.30			5.90		
Mass with holding brake m	kg	5.00			6.60		
Technical data - thermal							
Thermal time constant t_{th}	min	44			48		
Response threshold temperature sensor (PTC) T_{TK}	$^{\circ}C$ $(^{\circ}F)$	130 (266)					
1) RMS value at 1000 rpm and 20 $^{\circ}C$ (68 $^{\circ}F$).							

BSH...	1003			1004		
Winding	M	P	M	P	T	
Technical data - general¹⁾						
Continuous stall torque $M_0^{2)}$	Nm	8	10			
Peak torque M_{max}	Nm	28.3	40.5			
Number of pole pairs		4				
With supply voltage $U_n = 115$ Vac						
Nominal speed of rotation n_N	rpm	500	1000	375	750	1500
Nominal torque M_N	Nm	7.80	7.50	10.00	9.90	9.50
Nominal current I_N	A_{rms}	3.34	6.30	3.20	6.25	12.60
Nominal power P_N	kW	0.41	0.79	0.39	0.78	2.48
With supply voltage $U_n = 230$ Vac						
Nominal speed of rotation n_N	rpm	1000	2000	750	1500	3000
Nominal torque M_N	Nm	7.50	7.00	9.90	9.50	7.90
Nominal current I_N	A_{rms}	3.27	5.90	3.20	6.10	10.90
Nominal power P_N	kW	0.79	1.47	0.78	1.49	2.48
With supply voltage $U_n = 400$ Vac						
Nominal speed of rotation n_N	rpm	2000	4000	1500	3000	3000
Nominal torque M_N	Nm	7.00	5.70	9.50	7.90	7.90
Nominal current I_N	A_{rms}	3.10	4.90	3.20	5.30	10.90
Nominal power P_N	kW	1.47	2.39	1.49	2.48	2.48
With supply voltage $U_n = 480$ Vac						
Nominal speed of rotation n_N	rpm	2400	4800	1800	3600	3600
Nominal torque M_N	Nm	6.76	5.10	9.30	6.90	6.90
Nominal current I_N	A_{rms}	3.00	4.40	3.15	4.80	9.80
Nominal power P_N	kW	1.70	2.56	1.75	2.60	2.60
1) Conditions for performance data: Mounted to steel plate (2.5 x flange dimension) ² area, 10 mm (0.39 in) thickness, centered hole. 2) M_0 = Continuous stall torque at 20 rpm and 100% duty cycle; at speeds of rotation less than 20 rpm the continuous stall torque is reduced to 87%.						

BSH...	1003			1004		
Winding	M	P	M	P	T	
Technical data - electrical						
Maximum winding voltage U_{max}	Vac	480	480	480	480	480
Maximum winding voltage U_{max}	Vdc	680	680	680	680	680
Maximum voltage to ground	Vac	280	280	280	280	280
Maximum current I_{max}	A_{rms}	14.70	28.30	16.80	32.30	66.30
Continuous stall current I_0	A_{rms}	3.40	6.60	3.20	6.20	12.70
Voltage constant $k_{E-u-v^{1)}$	V_{rms}	148.00	77.00	198.00	103.00	50.00
Torque constant k_t	Nm/A	2.35	1.22	3.13	1.62	0.79
Winding resistance R_{20u-v}	Ω	5.30	1.43	6.70	1.81	0.45
Winding inductance L_{q-u-v}	mH	34.80	9.40	48.10	13.00	3.10
Winding inductance L_{d-u-v}	mH	30.00	8.10	39.60	10.70	2.50
1) RMS value at 1000 rpm and 20 °C (68 °F).						

BSH...		1003		1004		
Winding		M	P	M	P	T
Technical data - mechanical - with hardware version \geq RS02						
Maximum permissible speed of rotation n_{\max}	rpm	6000				
Rotor inertia without holding brake J_M	kgcm ²	2.718		3.613		
Rotor inertia with holding brake J_M	kgcm ²	3.521		4.416		
Mass without holding brake m	kg	7.70		9.40		
Mass with holding brake m	kg	8.40		10.30		
Technical data - mechanical - with hardware version $<$ RS02						
Maximum permissible speed of rotation n_{\max}	rpm	6000				
Rotor inertia without holding brake J_M	kgcm ²	2.718		3.613		
Rotor inertia with holding brake J_M	kgcm ²	3.838		5.245		
Mass without holding brake m	kg	7.50		9.10		
Mass with holding brake m	kg	8.20		9.80		
Technical data - thermal						
Thermal time constant t_{th}	min	56		58		
Response threshold temperature sensor (PTC) T_{TK}	°C (°F)	130 (266)				
1) RMS value at 1000 rpm and 20 °C (68 °F).						

BSH140

BSH...		1401			1402		
Winding		M	P	T	M	P	T
Technical data - general¹⁾							
Continuous stall torque $M_0^{2)}$	Nm	11.1			19.5		
Peak torque M_{\max}	Nm	27			60.1		
Number of pole pairs		5					
With supply voltage $U_n = 115$ Vac							
Nominal speed of rotation n_N	rpm	375	750	1500	375	750	1500
Nominal torque M_N	Nm	11.00	10.95	10.60	19.10	18.60	17.10
Nominal current I_N	A_{rms}	4.00	7.80	13.60	6.70	12.80	20.40
Nominal power P_N	kW	0.43	0.86	1.67	0.75	1.46	2.69
With supply voltage $U_n = 230$ Vac							
Nominal speed of rotation n_N	rpm	750	1500	3000	750	1500	3000
Nominal torque M_N	Nm	10.95	10.60	9.20	18.60	17.10	12.30
Nominal current I_N	A_{rms}	4.00	7.60	12.10	6.60	12.00	15.20
Nominal power P_N	kW	0.86	1.67	2.89	1.46	2.69	3.86
With supply voltage $U_n = 400$ Vac							
Nominal speed of rotation n_N	rpm	1500	3000	3000	1500	3000	3000
Nominal torque M_N	Nm	10.60	9.20	9.20	17.10	12.30	12.30
Nominal current I_N	A_{rms}	4.00	6.80	12.10	6.30	8.90	15.20
Nominal power P_N	kW	1.67	2.89	2.89	2.69	3.86	3.86
1) Conditions for performance data: Mounted to steel plate (2.5 x flange dimension) ² area, 10 mm (0.39 in) thickness, centered hole. 2) M_0 = Continuous stall torque at 20 rpm and 100% duty cycle; at speeds of rotation less than 20 rpm the continuous stall torque is reduced to 87%.							

BSH...	1401			1402		
Winding	M	P	T	M	P	T
Technical data - general¹⁾						
With supply voltage $U_n = 480$ Vac						
Nominal speed of rotation n_N	rpm	1800	3600	3600	1800	3600
Nominal torque M_N	Nm	10.40	8.40	8.40	16.30	9.70
Nominal current I_N	A_{rms}	4.00	6.30	11.15	6.10	7.10
Nominal power P_N	kW	1.96	3.17	3.17	3.07	3.66
1) Conditions for performance data: Mounted to steel plate (2.5 x flange dimension) ² area, 10 mm (0.39 in) thickness, centered hole. 2) M_0 = Continuous stall torque at 20 rpm and 100% duty cycle; at speeds of rotation less than 20 rpm the continuous stall torque is reduced to 87%.						

BSH...	1401			1402		
Winding	M	P	T	M	P	T
Technical data - electrical						
Maximum winding voltage U_{max}	Vac	480	480	480	480	480
Maximum winding voltage U_{max}	Vdc	680	680	680	680	680
Maximum voltage to ground	Vac	280	280	280	280	280
Maximum current I_{max}	A_{rms}	10.80	20.80	37.10	22.40	44.10
Continuous stall current I_0	A_{rms}	4.00	7.80	13.90	6.70	13.20
Voltage constant $k_{E u-v^1)}$	V_{rms}	193.00	100.00	56.00	199.00	101.00
Torque constant k_t	Nm/A	2.78	1.43	0.80	2.91	1.47
Winding resistance $R_{20 u-v}$	Ω	5.30	1.41	0.44	2.32	0.60
Winding inductance $L_q u-v$	mH	60.90	16.30	5.10	29.80	7.70
Winding inductance $L_d u-v$	mH	55.30	14.84	4.70	27.20	7.05
Technical data - mechanical - with hardware version \geqRS02						
Maximum permissible speed of rotation n_{max}	rpm	4000				
Rotor inertia without holding brake J_M	kgcm ²	6.941				12.162
Rotor inertia with holding brake J_M	kgcm ²	8.542				14.824
Mass without holding brake m	kg	11.50				16.50
Mass with holding brake m	kg	12.90				18.10
Technical data - mechanical - with hardware version $<$RS02						
Maximum permissible speed of rotation n_{max}	rpm	4000				
Rotor inertia without holding brake J_M	kgcm ²	6.941				12.162
Rotor inertia with holding brake J_M	kgcm ²	9.210				14.480
Mass without holding brake m	kg	11.20				16.10
Mass with holding brake m	kg	12.60				17.40
Technical data - thermal						
Thermal time constant t_{th}	min	64				74
Response threshold temperature sensor (PTC) T_{TK}	$^{\circ}C$ ($^{\circ}F$)	130 (266)				
1) RMS value at 1000 rpm and 20 $^{\circ}C$ (68 $^{\circ}F$).						

BSH...	1403			1404		
Winding	M	P	T	M	P	
Technical data - general¹⁾						
Continuous stall torque $M_0^{2)}$	Nm	27.8			33.4	
Peak torque M_{max}	Nm	90.2			131.9	
Number of pole pairs		5				
With supply voltage $U_n = 115$ Vac						
Nominal speed of rotation n_N	rpm	375	750	1500	375	750
Nominal torque M_N	Nm	26.30	24.70	21.20	31.90	30.20
Nominal current I_N	A_{rms}	8.70	15.90	17.00	10.40	19.60
Nominal power P_N	kW	1.03	1.94	3.33	1.25	2.37
With supply voltage $U_n = 230$ Vac						
Nominal speed of rotation n_N	rpm	750	1500	3000	750	1500
Nominal torque M_N	Nm	24.70	21.20	12.90	30.20	26.30
Nominal current I_N	A_{rms}	8.30	13.90	10.30	10.00	17.40
Nominal power P_N	kW	1.94	3.33	4.05	2.37	4.13
With supply voltage $U_n = 400$ Vac						
Nominal speed of rotation n_N	rpm	1500	3000	3000	1500	3000
Nominal torque M_N	Nm	21.20	12.90	12.90	26.30	16.10
Nominal current I_N	A_{rms}	7.30	8.70	10.30	9.00	11.00
Nominal power P_N	kW	3.33	4.05	4.05	4.13	5.06
With supply voltage $U_n = 480$ Vac						
Nominal speed of rotation n_N	rpm	1800	3600	3600	1800	3600
Nominal torque M_N	Nm	19.70	9.10	9.10	24.50	11.10
Nominal current I_N	A_{rms}	6.90	6.20	7.30	8.50	7.70
Nominal power P_N	kW	3.71	3.43	3.43	4.62	4.19
1) Conditions for performance data: Mounted to steel plate (2.5 x flange dimension) ² area, 10 mm (0.39 in) thickness, centered hole. 2) M_0 = Continuous stall torque at 20 rpm and 100% duty cycle; at speeds of rotation less than 20 rpm the continuous stall torque is reduced to 87%.						

BSH...	1403			1404		
Winding	M	P	T	M	P	
Technical data - electrical						
Maximum winding voltage U_{max}	Vac	480	480	480	480	
Maximum winding voltage U_{max}	Vdc	680	680	680	680	
Maximum voltage to ground	Vac	280	280	280	280	
Maximum current I_{max}	A_{rms}	31.30	61.00	81.30	47.80	95.60
Continuous stall current I_0	A_{rms}	9.00	17.60	22.30	10.70	21.30
Voltage constant $k_E U-v^{1)}$	V_{rms}	205.00	105.00	78.00	208.00	104.00
Torque constant k_t	Nm/A	3.09	1.58	1.25	3.12	1.57
Winding resistance R_{20U-v}	Ω	1.52	0.40	0.22	1.12	0.28
Winding inductance $L_q U-v$	mH	20.20	5.30	2.70	16.30	4.10
Winding inductance $L_d U-v$	mH	18.40	4.84	3.00	14.80	3.69
1) RMS value at 1000 rpm and 20 °C (68 °F).						

BSH...	1403			1404	
Winding	M	P	T	M	P
Technical data - mechanical - with hardware version \geq RS02					
Maximum permissible speed of rotation n_{\max}	rpm	4000			
Rotor inertia without holding brake J_M	kgcm ²	17.383		22.604	
Rotor inertia with holding brake J_M	kgcm ²	21.559		26.794	
Mass without holding brake m	kg	21.90		27.00	
Mass with holding brake m	kg	24.00		29.30	
Technical data - mechanical - with hardware version $<$ RS02					
Maximum permissible speed of rotation n_{\max}	rpm	4000			
Rotor inertia without holding brake J_M	kgcm ²	17.383		22.604	
Rotor inertia with holding brake J_M	kgcm ²	23.440		29.200	
Mass without holding brake m	kg	21.30		26.30	
Mass with holding brake m	kg	23.20		28.40	
Technical data - thermal					
Thermal time constant t_{th}	min	79			83
Response threshold temperature sensor (PTC) T_{TK}	°C (°F)	130 (266)			
1) RMS value at 1000 rpm and 20 °C (68 °F).					

BSH205

BSH...	2051		2052		2053		
Winding	M	P	M	P	M	P	
Technical data - general¹⁾							
Continuous stall torque $M_0^{2)}$	Nm	36.90		64.90		94.40	
Peak torque M_{\max}	Nm	110		220		330	
Number of pole pairs		5					
With supply voltage $U_n = 115$ Vac							
Nominal speed of rotation n_N	rpm	375	750	250	500	250	500
Nominal torque M_N	Nm	34.40	31.90	63.50	61.60	89.90	84.90
Nominal current I_N	A_{rms}	10.50	18.80	13.00	25.40	16.30	30.80
Nominal power P_N	kW	1.35	2.51	1.66	3.23	2.35	4.45
With supply voltage $U_n = 230$ Vac							
Nominal speed of rotation n_N	rpm	750	1500	500	1000	500	1000
Nominal torque M_N	Nm	31.90	27.00	61.60	56.00	84.90	74.40
Nominal current I_N	A_{rms}	10.10	16.50	12.60	24.00	16.00	27.90
Nominal power P_N	kW	2.51	4.24	3.23	5.86	4.45	7.79
With supply voltage $U_n = 400$ Vac							
Nominal speed of rotation n_N	rpm	1500	3000	1000	2000	1000	2000
Nominal torque M_N	Nm	27.00	17.50	56.00	38.10	74.40	50.70
Nominal current I_N	A_{rms}	9.20	11.50	11.50	17.80	15.00	20.40
Nominal power P_N	kW	4.24	5.50	5.86	7.98	7.79	10.62
1) Conditions for performance data: Mounted to steel plate (2.5 x flange dimension) ² area, 10 mm (0.39 in) thickness, centered hole.							
2) M_0 = Continuous stall torque at 20 rpm and 100% duty cycle; at speeds of rotation less than 20 rpm the continuous stall torque is reduced to 87%.							

BSH...	2051		2052		2053		
Winding	M	P	M	P	M	P	
Technical data - general¹⁾							
With supply voltage $U_n = 480$ Vac							
Nominal speed of rotation n_N	rpm	1800	3600	1200	2400	1200	2400
Nominal torque M_N	Nm	25.10	13.80	53.10	28.40	70.00	40.20
Nominal current I_N	A_{rms}	8.80	9.40	10.90	13.80	14.50	16.70
Nominal power P_N	kW	4.73	5.20	6.67	7.14	8.80	10.10
1) Conditions for performance data: Mounted to steel plate (2.5 x flange dimension) ² area, 10 mm (0.39 in) thickness, centered hole. 2) M_0 = Continuous stall torque at 20 rpm and 100% duty cycle; at speeds of rotation less than 20 rpm the continuous stall torque is reduced to 87%.							

BSH...	2051		2052		2053		
Winding	M	P	M	P	M	P	
Technical data - electrical							
Maximum winding voltage U_{max}	Vac	480	480	480	480	480	
Maximum winding voltage U_{max}	Vdc	680	680	680	680	680	
Maximum voltage to ground	Vac	280	280	280	280	280	
Maximum current I_{max}	A_{rms}	45.20	87.20	49.60	96.80	68.00	136.10
Continuous stall current I_0	A_{rms}	10.90	21.00	13.20	25.70	16.60	33.20
Voltage constant $k_E u-v^1)$	V_{rms}	200.00	104.00	314.00	161.00	344.00	172.00
Torque constant k_t	Nm/A	3.10	1.60	5.04	2.58	5.50	2.76
Winding resistance R_{20u-v}	Ω	1.10	0.30	1.10	0.30	0.80	0.20
Winding inductance L_{qu-v}	mH	21.90	5.90	21.20	5.60	17.10	4.30
Winding inductance L_{d-u-v}	mH	20.80	5.60	20.00	5.20	16.10	4.00
Technical data - mechanical - with hardware version <RS02							
Maximum permissible speed of rotation n_{max}	rpm	3800					
Rotor inertia without holding brake J_M	kgcm ²	71.40		129		190	
Rotor inertia with holding brake J_M	kgcm ²	87.40		145		206	
Mass without holding brake m	kg	35.00		50.00		67.00	
Mass with holding brake m	kg	38.60		53.60		70.60	
Technical data - thermal							
Thermal time constant t_{th}	min	73		88		101	
Response threshold temperature sensor (PTC) T_{TK}	$^{\circ}C$ $(^{\circ}F)$	130 (266)					
1) RMS value at 1000 rpm and 20 $^{\circ}C$ (68 $^{\circ}F$).							

Encoder

The motors are equipped with a SinCos encoder. The drive can access the electronic nameplate via the Hiperface interface for commissioning.

The signals meet the PELV requirements.

SKS36 Singleturn

This motor encoder measures an absolute value within one revolution at start-up and continues to count incrementally from this point.

Characteristic	Value
Resolution in increments	Depending on evaluation
Resolution per revolution	128 sin/cos periods
Measuring range absolute	1 revolution
Accuracy of the digital absolute value ¹⁾	$\pm 0.0889^\circ$
Accuracy of the incremental position	$\pm 0.0222^\circ$
Signal shape	Sinusoidal
Supply voltage	7 ... 12 Vdc
Maximum supply current	60 mA (without load)
Maximum angular acceleration	200000 rad/s ²
1) Depending on the evaluation through the drive, the accuracy may be increased by including the incremental position in the calculation of the absolute value. In this case, the accuracy corresponds to the incremental position.	

SKM36 Multiturn

This motor encoder measures an absolute value within 4096 revolutions at start-up and continues to count incrementally from this point.

Characteristic	Value
Resolution in increments	Depending on evaluation
Resolution per revolution	128 sin/cos periods
Measuring range absolute	4096 revolutions
Accuracy of the digital absolute value ¹⁾	$\pm 0.0889^\circ$
Accuracy of the incremental position	$\pm 0.0222^\circ$
Signal shape	Sinusoidal
Supply voltage	7 ... 12 Vdc
Maximum supply current	60 mA (without load)
Maximum angular acceleration	200000 rad/s ²
1) Depending on the evaluation through the drive, the accuracy may be increased by including the incremental position in the calculation of the absolute value. In this case, the accuracy corresponds to the incremental position.	

SEK37 Singleturn

This motor encoder measures an absolute value within one revolution at start-up and continues to count incrementally from this point.

Characteristic	Value
Resolution in increments	Depending on evaluation
Resolution per revolution	16 sin/cos periods
Measuring range absolute	1 revolution
Accuracy of position	$\pm 0.08^\circ$
Signal shape	Sinusoidal
Supply voltage	7 ... 12 Vdc
Maximum supply current	50 mA (without load)

SEL37 Multiturn

This motor encoder measures an absolute value within 4096 revolutions at start-up and continues to count incrementally from this point.

Characteristic	Value
Resolution in increments	Depending on evaluation
Resolution per revolution	16 sin/cos periods
Measuring range absolute	4096 revolutions
Accuracy of position	$\pm 0.08^\circ$
Signal shape	Sinusoidal
Supply voltage	7 ... 12 Vdc
Maximum supply current	50 mA (without load)

Holding Brake

Hardware version ≥RS02:

BSH...		040	055	070	1001, 1002	1003, 1004	1401	1402	1403, 1404	205
Holding torque ¹⁾	Nm (lb·in)	0.4 (3.54)	0.8 (7.08)	3.0 (26.6)	5.5 (48.7)	10 (88.5)	18 (159)	23 (204)	33 (292)	80 (708)
Opening time	ms	24	16	80	70	90	100	100	200	200
Coupling time	ms	13	21	17	30	25	50	40	60	50
Nominal voltage	Vdc	24 +15% -15%	24 +6% -10%	24 +5% -15%	24 +5% -15%	24 +5% -15%	24 +5% -15%	24 +5% -15%	24 +5% -15%	24 +6% -10%
Nominal power (electrical pull-in power)	W	5.8	10	7	12	18	18	19	22.5	40
Maximum speed of rotation during braking of moving loads	rpm	3000	3000	3000	3000	3000	3000	3000	3000	3000
Maximum number of decelerations during braking of moving loads and 3000 rpm		500	500	500	500	500	500	500	500	500
Maximum number of decelerations during braking of moving loads per hour (at even distribution)		20	20	20	20	20	20	20	20	20
Maximum kinetic energy that can be transformed into heat per deceleration during braking of moving loads	J	10	120	130	150	150	550	550	850	21000
1) The holding brake is broken-in at the factory. If the holding brake is not used for an extended period of time, parts of the holding brake may corrode. Corrosion reduces the holding torque.										

Hardware version <RS02:

BSH...		055	0701, 0702	0703	1001, 1002, 1003	1004	1401, 1402	1403, 1404	205
Holding torque ¹⁾	Nm (lb·in)	0.8 (7.08)	2 (17.7)	3 (26.6)	9 (79.7)	12 (106)	23 (204)	36 (319)	80 (708)
Opening time	ms	12	12	35	42	64	84	63	110
Coupling time	ms	6	6	15	38	37	61	73	140
Nominal voltage	Vdc	24 +6% -10%	24 +6% -10%	24 +6% -10%	24 +6% -10%	24 +6% -10%	24 +6% -10%	24 +6% -10%	24 +6% -10%
Nominal power (electrical pull-in power)	W	10	10	12	18	17	24	26	40
1) The holding brake is broken-in at the factory. If the holding brake is not used for an extended period of time, parts of the holding brake may corrode. Corrosion reduces the holding torque.									

Certifications

Product Certifications

Certified by	Assigned number
UL	File E208613

Conditions for UL 1004-1, UL 1004-6 and CSA 22.2 No. 100

PELV Power Supply

Use only power supply units that are approved for overvoltage category III.

Wiring

Use at least 60/75 °C (140/167 °F) copper conductors.

Chapter 3

Installation

DANGER

ELECTRIC SHOCK CAUSED BY INSUFFICIENT GROUNDING

- Verify compliance with all local and national electrical code requirements as well as all other applicable regulations with respect to grounding of the entire drive system.
- Ground the drive system before applying voltage.
- Do not use conduits as protective ground conductors; use a protective ground conductor inside the conduit.
- The cross section of the protective ground conductor must comply with the applicable standards.
- Do not consider cable shields to be protective ground conductors.

Failure to follow these instructions will result in death or serious injury.

DANGER

ELECTRIC SHOCK OR UNINTENDED EQUIPMENT OPERATION

- Keep foreign objects (such as chips, screws or wire clippings) from getting into the product.
- Verify the correct seating of seals and cable entries in order to avoid contamination such as deposits and humidity.

Failure to follow these instructions will result in death or serious injury.

This equipment has been designed to operate outside of any hazardous location. Only install this equipment in zones known to be free of a hazardous atmosphere.

DANGER

POTENTIAL FOR EXPLOSION

Install and use this equipment in non-hazardous locations only.

Failure to follow these instructions will result in death or serious injury.

Motors are very heavy relative to their size. The great mass of the motor can cause injuries and damage. The motor may move, tip and fall as a result of incorrect or insufficient mounting.

WARNING

HEAVY AND/OR FALLING PARTS

- Use a suitable crane or other suitable lifting gear for mounting the motor if this is required by the weight of the motor.
- Use the necessary personal protective equipment (for example, protective shoes, protective glasses and protective gloves).
- Mount the motor so that it cannot come loose (use of securing screws with appropriate tightening torque), especially in cases of fast acceleration or continuous vibration.

Failure to follow these instructions can result in death, serious injury, or equipment damage.

Motors can generate strong local electrical and magnetic fields. This can cause interference in electromagnetically sensitive devices.

⚠ WARNING
ELECTROMAGNETIC FIELDS <ul style="list-style-type: none">• Keep persons with electronic medical implants, such as pacemakers, away from the motor.• Do not place electromagnetically sensitive devices in the vicinity of the motor. Failure to follow these instructions can result in death, serious injury, or equipment damage.

The metal surfaces of the product may exceed 70 °C (158 °F) during operation.

⚠ WARNING
HOT SURFACES <ul style="list-style-type: none">• Avoid unprotected contact with hot surfaces.• Do not allow flammable or heat-sensitive parts in the immediate vicinity of hot surfaces.• Verify that the heat dissipation is sufficient by performing a test run under maximum load conditions. Failure to follow these instructions can result in death, serious injury, or equipment damage.

⚠ WARNING
IMPROPER APPLICATION OF FORCES <ul style="list-style-type: none">• Do not use the motor as a step to climb into or onto the machine.• Do not use the motor as a load-bearing part.• Use hazard labels and guards on your machine to help prevent the improper application of forces on the motor. Failure to follow these instructions can result in death, serious injury, or equipment damage.

What Is in This Chapter?

This chapter contains the following sections:

Section	Topic	Page
3.1	Electromagnetic Compatibility (EMC)	55
3.2	Mechanical Installation	57
3.3	Electrical Installation	66

Section 3.1

Electromagnetic Compatibility (EMC)

Electromagnetic Compatibility (EMC)

The measures for electromagnetic compatibility (EMC) are intended to minimize electromagnetic interference of the device and interference caused by the device that affects the environment. Such measures include measures to reduce interference and emission as well as to increase immunity.

Electromagnetic compatibility hinges to a great extent on the individual components used in the system. The EMC measures described in this manual may help to comply with the requirements of IEC 61800-3. You must comply with all EMC regulations of the country in which the product is operated. Also, respect any special EMC regulations that may apply at the installation site (for example, residential environments or airports).

Signal interference can cause unexpected responses of the drive system and of other equipment in the vicinity of the drive system.

WARNING

SIGNAL AND EQUIPMENT INTERFERENCE

- Install the wiring in accordance with the EMC requirements described in the present document.
- Verify compliance with the EMC requirements described in the present document.
- Verify compliance with all EMC regulations and requirements applicable in the country in which the product is to be operated and with all EMC regulations and requirements applicable at the installation site.

Failure to follow these instructions can result in death, serious injury, or equipment damage.

Motor and Encoder Cables

In terms of EMC, motor cables are especially critical since they are particularly prone to causing interference.

When planning the wiring, take into account the fact that the motor cable must be routed separately. The motor cable must be separate from mains cables or signal cables (for example, limit switches). Use only pre-assembled cables or cables that comply with the specifications and implement the EMC measures described below.

EMC measures	Effect
Keep cables as short as possible. Do not install unnecessary cable loops. Use short cables from the central grounding point in the control cabinet to the external ground connection.	Reduces capacitive and inductive interference.
Ensure that there is a ground connection between the motor flange and the mounting surface on the machine (no paint, oil and grease or any insulating material between the motor flange and the mounting surface on the machine).	Reduces emissions, increases immunity.
Connect large surface areas of cable shields, use cable clamps and ground straps.	Reduces emissions.
Do not install switching elements in motor cables or encoder cables.	Reduces interference.
Route the motor cable separately from mains cables and signal cables (for example, for limit switches), for example by using shielding plates or by keeping the cables apart from each other at a distance of at least 20 cm (5.08 in).	Reduces mutual interference.
Route the motor cable and encoder cable without cutting them. ⁽¹⁾	Reduces emission.
(1) If a cable is cut for the installation, take appropriate measures for uninterrupted shielding (such as a metal housing) at the point of the cut. Connect a large area of the cable shield to the metal housing at both ends of the cut.	

Pre-Assembled Connection Cables (Accessories)

Using pre-assembled cables helps to reduce the possibility of wiring errors. See chapter Accessories and Spare Parts (*see page 83*).

Equipotential Bonding Conductors

Potential differences can result in excessive currents on the cable shields. Use equipotential bonding conductors to reduce currents on the cable shields.

 WARNING
--

UNINTENDED EQUIPMENT OPERATION

- | |
|---|
| <ul style="list-style-type: none">● Use shielded cables for all fast I/O, analog I/O and communication signals.● Ground cable shields for all analog I/O, fast I/O and communication signals at a single point¹.● Route communication and I/O cables separately from power cables. |
|---|

Failure to follow these instructions can result in death, serious injury, or equipment damage.

¹Multipoint grounding is permissible if connections are made to an equipotential ground plane dimensioned to help avoid cable shield damage in the event of power system short-circuit currents.

Section 3.2

Mechanical Installation

What Is in This Section?

This section contains the following topics:

Topic	Page
Before Mounting	58
Cable Specifications	60
Mounting The Motor	63
Installation and Connection of IP67 Kit (Accessory)	65

Before Mounting

Inspecting The Product

- Verify the product version by means of the type code on the nameplate. See chapter Nameplate (*see page 13*) and chapter Type Code (*see page 15*).
- Prior to mounting, inspect the product for visible damage.

Damaged products may cause electric shock or unintended equipment operation.

 DANGER
ELECTRIC SHOCK OR UNINTENDED EQUIPMENT OPERATION
<ul style="list-style-type: none">• Do not use damaged products.• Keep foreign objects (such as chips, screws or wire clippings) from getting into the product.
Failure to follow these instructions will result in death or serious injury.

Contact your local Schneider Electric sales office if you detect any damage whatsoever to the products.

Inspecting the Holding Brake (Option)

See chapter Inspecting/Breaking In the Holding Brake (*see page 58*).

Cleaning the Shaft

The shaft extensions are factory-treated with an anti-corrosive. If output components are glued to the shaft, the anti-corrosive must be removed and the shaft cleaned. If required, use a grease removal agent as specified by the glue manufacturer. If the glue manufacturer does not provide information on grease removal, acetone may be used.

- Remove the anti-corrosive. Avoid direct contact of the skin and the sealing parts with the anti-corrosive or the cleaning agent.

Mounting Surface for Flange

The mounting surface must be stable, clean, deburred and low-vibration. Ensure that the mounting surface is itself grounded, and that a potential exists between the motor flange and the mounting surface.

 DANGER
ELECTRIC SHOCK CAUSED BY INSUFFICIENT GROUNDING
<ul style="list-style-type: none">• Verify compliance with all local and national electrical code requirements as well as all other applicable regulations with respect to grounding of the entire drive system.• Ground the drive system before applying voltage.• Do not use conduits as protective ground conductors; use a protective ground conductor inside the conduit.• The cross section of the protective ground conductor must comply with the applicable standards.• Do not consider cable shields to be protective ground conductors.
Failure to follow these instructions will result in death or serious injury.

Verify that the mounting surface meets the requirements in terms of dimensions and tolerances in this document.

Conductor Cross Sections According to Method of Installation

The following sections describe the conductor cross sections for two methods of installation:

- Method of installation B2:
Cables in conduits or cable trunking systems
- Method of installation E:
Cables on open cable trays

Cross section in mm ² (AWG)	Current-carrying capacity with method of installation B2 in A ¹⁾	Current carrying capacity with method of installation E in A ¹⁾
0.75 (18)	8.5	10.4
1 (16)	10.1	12.4
1.5 (14)	13.1	16.1
2.5 (12)	17.4	22
4 (10)	23	30
6 (8)	30	37
10 (6)	40	52
16 (4)	54	70
25 (2)	70	88

1) Values as per IEC 60204-1 for continuous operation, copper conductors and ambient air temperature 40°C (104 °F); see IEC 60204-1 for additional information.

Note the derating factors for grouping of cables and correction factors for other ambient conditions (IEC 60204-1).

The conductors must have a sufficiently large cross section so that the upstream fuse can trip.

In the case of longer cables, it may be necessary to use a greater conductor cross section to reduce the energy losses.

Cable Specifications

Using pre-assembled cables helps to reduce the possibility of wiring errors. See chapter Accessories and Spare Parts (*see page 83*).

The genuine accessories have the following properties:

Motor Cable With Connector

VW3...		M5100R...	M5101R...	M5102R...	M5103R...	M5105R...	M5104R...
Cable jacket, insulation		PUR orange (RAL 2003), TPM	PUR orange (RAL 2003), polypropylene (PP)				
Capacitance power wires							
Wire/wire	pF/m	80	80	80	90	85	100
Wire/shield	pF/m	145	135	150	150	150	160
Number of contacts (shielded)		(4 x 1 mm ² + 2 x (2 x 0.75 mm ²))	(4 x 1.5 mm ² + (2 x 1 mm ²))	(4 x 2.5 mm ² + (2 x 1 mm ²))	(4 x 4 mm ² + (2 x 1 mm ²))	(4 x 6 mm ² + (2 x 1 mm ²))	(4 x 10 mm ² + (2 x 1 mm ²))
Connector motor side		8-pin circular Y-TEC	8-pin circular M23		8-pin circular M40		
Connector drive side		Open					
Cable diameter	mm (in)	11 ± 0.3 (0.43 ± 0.01)	12 ± 0.2 (0.47 ± 0.01)	14.3 ± 0.3 (0.55 ± 0.01)	16.3 ± 0.3 (0.64 ± 0.01)	18.8 ± 0.4 (0.74 ± 0.02)	23.5 ± 0.6 (0.93 ± 0.02)
Minimum bend radius with permanently installed connection		10 times the cable diameter	5 times the cable diameter				
Minimum bend radius with flexible installation		10 times the cable diameter	7.5 times the cable diameter			10 times the cable diameter	
Nominal voltage							
Motor phases	V	1000	600				
Holding brake	V	1000	300				
Maximum orderable length	m (ft)	25 (82)	75 (246)				
Permissible temperature range during operation with permanently installed connection	°C (°F)	-40 ... 80 (-40 ... 176)					
Permissible temperature range during operation with flexible installation	°C (°F)	-20 ... 60 (-4 ... 140)	-20 ... 80 (-4 ... 176)				
Certifications / declaration of conformity		CE, DESINA					

Motor Cable Without Connector

VW3...		M5300R...	M5301R...	M5302R...	M5303R...	M5305R...	M5304R...
Cable jacket, insulation		PUR orange (RAL 2003), TPM	PUR orange (RAL 2003), polypropylene (PP)				
Capacitance power wires							
Wire/wire	pF/m	80	80	80	90	85	100
Wire/shield	pF/m	145	135	150	150	150	160
Number of contacts (shielded)		(4 x 1 mm ² + 2 x (2 x 0.75 mm ²))	(4 x 1.5 mm ² + (2 x 1 mm ²))	(4 x 2.5 mm ² + (2 x 1 mm ²))	(4 x 4 mm ² + (2 x 1 mm ²))	(4 x 6 mm ² + (2 x 1 mm ²))	(4 x 10 mm ² + (2 x 1 mm ²))
Connector motor side		Open					
Connector drive side		Open					
Cable diameter	mm (in)	11 ± 0.3 (0.43 ± 0.01)	12 ± 0.2 (0.47 ± 0.01)	14.3 ± 0.3 (0.55 ± 0.01)	16.3 ± 0.3 (0.64 ± 0.01)	18.8 ± 0.4 (0.74 ± 0.02)	23.5 ± 0.6 (0.93 ± 0.02)
Minimum bend radius with permanently installed connection		10 times the cable diameter	5 times the cable diameter				

VW3...		M5300R...	M5301R...	M5302R...	M5303R...	M5305R...	M5304R...
Minimum bend radius with flexible installation		10 times the cable diameter	7.5 times the cable diameter			10 times the cable diameter	
Nominal voltage Motor phases Holding brake	V	1000 1000	600 300				
Maximum orderable length	m (ft)	100 (328)					
Permissible temperature range during operation with permanently installed connection	°C (°F)	-40 ... 80 (-40 ... 176)					
Permissible temperature range during operation with flexible installation	°C (°F)	-20 ... 60 (-4 ... 140)	-20 ... 80 (-4 ... 176)				
Certifications / declaration of conformity		CE, c-UR-us, DESINA					

Encoder Cable With and Without Connectors

VW3...		M8100R...	M8102R...	M8222R...
Cable jacket, insulation		PUR green (RAL 6018), polypropylene (PP)		
Capacitance	pF/m	Approx. 135 (wire/wire)		
Number of contacts (shielded)		(3 x 2 x 0.14 mm ² + 2 x 0.34 mm ²)		
Connector motor side		12-pin circular Y-TEC	12-pin circular M23	Open
Connector drive side		10-pin RJ45	10-pin RJ45	Open
Cable diameter	mm (in)	6.8 ± 0.2 (0.27 ± 0.1)		
Minimum bend radius	mm (in)	68 (2.68)		
Nominal voltage	V	300		
Maximum orderable length	m (ft)	25 (82)	75 (246)	100 (328)
Permissible temperature range during operation with permanently installed connection	°C (°F)	-40 ... 80 (-40 ... 176)		
Permissible temperature range during operation with flexible installation	°C (°F)	-20 ... 80 (-4 ... 176)		
Certifications / declaration of conformity		DESINA		c-UR-us, DESINA

Clearance For Connectors

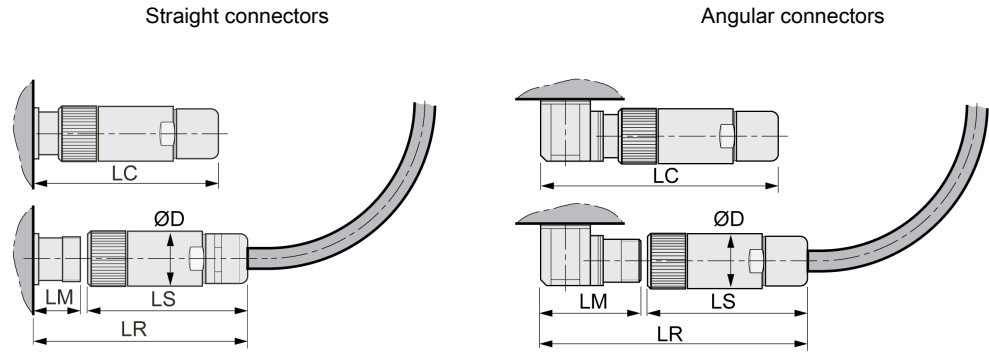

Dimensions		Motor connectors straight		Encoder connector straight
		M23	M40	M23
D	mm (in)	28 (1.1)	46 (1.81)	26 (1.02)
LS	mm (in)	76 (2.99)	100 (3.94)	51 (2.01)
LR	mm (in)	117 (4.61)	155 (6.1)	76 (2.99)
LC	mm (in)	100 (3.94)	145 (5.71)	60 (2.36)
LM	mm (in)	40 (1.57)	54 (2.13)	23 (0.91)

Dimensions		Motor connectors angular			Encoder connector angular	
		Y-TEC	M23	M40	Y-TEC	M23
D	mm (in)	18.7 (0.74)	28 (1.1)	46 (1.81)	18.7 (0.74)	26 (1.02)
LS	mm (in)	42 (1.65)	76 (2.99)	100 (3.94)	42 (1.65)	51 (2.01)
LR	mm (in)	100 (3.94)	132 (5.2)	191 (7.52)	100 (3.94)	105 (4.13)
LC	mm (in)	89 (3.50)	114 (4.49)	170 (6.69)	89 (3.50)	89 (3.5)
LM	mm (in)	58 (2.28)	55 (2.17)	91 (3.58)	58 (2.28)	52 (2.05)

Mounting The Motor

Electrostatic discharge to the shaft may cause incorrect operation of the encoder system and result in unanticipated motor movements and damage to the bearing.

⚠ WARNING

UNINTENDED MOVEMENT CAUSED BY ELECTROSTATIC DISCHARGE

Use conductive components such as antistatic belts or other suitable measures to avoid static charge by motion.

Failure to follow these instructions can result in death, serious injury, or equipment damage.

If the permissible environmental conditions are not respected, external substances from the environment may penetrate the product and cause unintended movement or equipment damage.

⚠ WARNING

UNINTENDED MOVEMENT

- Verify that the environmental conditions are respected.
- Do not allow seals to run dry.
- Keep liquids from getting to the shaft bushing
- Do not expose the shaft sealing rings and cable entries of the motor to the direct spray of a pressure washer.

Failure to follow these instructions can result in death, serious injury, or equipment damage.

The metal surfaces of the product may exceed 70 °C (158 °F) during operation.

⚠ WARNING

HOT SURFACES

- Avoid unprotected contact with hot surfaces.
- Do not allow flammable or heat-sensitive parts in the immediate vicinity of hot surfaces.
- Verify that the heat dissipation is sufficient by performing a test run under maximum load conditions.

Failure to follow these instructions can result in death, serious injury, or equipment damage.

Mounting Position

The following mounting positions are defined and permissible as per IEC 60034-7:

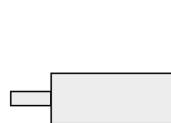

IM B5



IM V1



IM V3

Mounting

When the motor is mounted to the mounting surface, it must be accurately aligned axially and radially and make even contact with the mounting surface. All mounting screws must be tightened with the specified tightening torque. No uneven mechanical load must be applied when the mounting screws are tightened. See chapter Technical Data ([see page 17](#)) for data, dimensions and degrees of protection (IP).

Mounting Output Components

Output components such as pulleys and couplings must be mounted with suitable equipment and tools. Motor and output component must be accurately aligned both axially and radially. If the motor and the output component are not accurately aligned, this will cause runout and premature wear.

The maximum axial and radial forces acting on the shaft must not exceed the maximum shaft load values specified, see chapter Shaft-specific Data (*see page 34*).

If the maximum permissible forces at the motor shaft are exceeded, this will result in premature wear of the bearing or shaft breakage.

 WARNING
UNINTENDED EQUIPMENT OPERATION DUE TO MECHANICAL DAMAGE TO THE MOTOR
<ul style="list-style-type: none">● Do not exceed the maximum permissible axial and radial forces at the motor shaft.● Protect the motor shaft from impact.● Do not exceed the maximum permissible axial force when pressing components onto the motor shaft.
Failure to follow these instructions can result in death, serious injury, or equipment damage.

Installation and Connection of IP67 Kit (Accessory)

The IP67 kit is used to connect compressed air to the motor. Degree of protection IP65 is a prerequisite for the use of the IP67 kit. The compressed air generates a permanent overpressure inside the motor. This overpressure inside the motor is used to obtain degree of protection IP67.

Installation Procedure

When the IP67 kit is installed, the existing cover is replaced by the cover of the IP67 kit. The O-ring is also replaced (shipped with the IP67 kit).

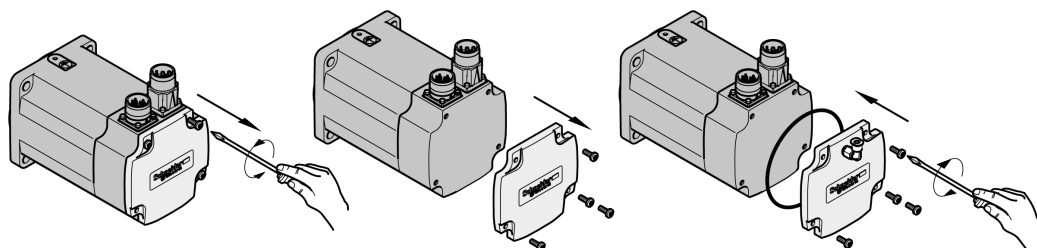

Step	Action
1	Loosen the 4 housing screws of the cover.
2	Remove the cover and the O-ring
3	<p>Verify proper seat of the O-ring in the cover of the IP67 kit. To facilitate mounting of the new O-ring, you may slightly grease the O-ring to hold it in place. Fasten the cover of the IP67 kit with the 4 housing screws:</p> <ul style="list-style-type: none"> ● Tightening torque of housing screws M3: 1 Nm (8.85 lb•in) ● Tightening torque of housing screws M4: 1.5 Nm (13.28 lb•in) ● Tightening torque of housing screws M5: 5 Nm (44.3 lb•in) <p>Verify the tightening torque of the compressed air connection:</p> <ul style="list-style-type: none"> ● Tightening torque compressed air connection: 0.6 Nm (5.31 lb•in)

Compressed Air Connection

The compressed air connection of the L-shaped push-in fitting is designed for compressed air hoses made of standard plastic with a nominal diameter of 4 mm.

Compressed Air Monitoring

Use a compressed air monitor.

Section 3.3

Electrical Installation

What Is in This Section?

This section contains the following topics:

Topic	Page
Connectors and Connector Assignments	67
Power and Encoder Connection	71
Holding Brake Connection	77

Connectors and Connector Assignments

Connection Overview

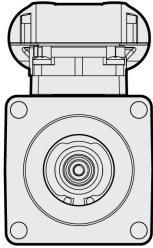
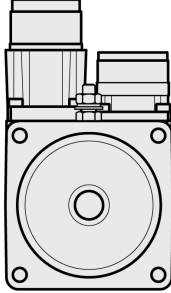
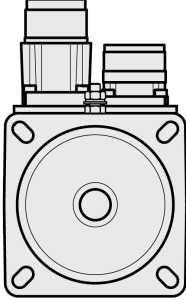
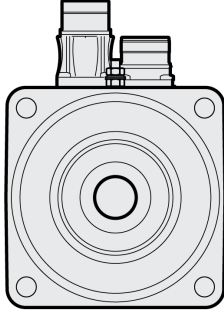
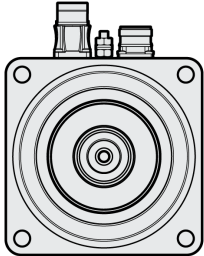
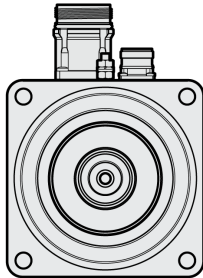
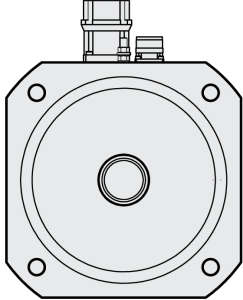
Overview of the connections			
BSH040	BSH055	BSH070	BSH100
CN1 Y-TEC 	CN1 M23 CN2 M23 	CN1 M23 CN2 M23 	CN1 M23 CN2 M23 
BSH1401, BSH1402M, BSH1402P, BSH1403M, BSH1403P, BSH1404M		BSH1402T, BSH1403T, BSH1404P	
CN1 M23 CN2 M23 		CN1 M40 CN2 M23 	
		CN1 M40 CN2 M23 	
CN1 Motor connection CN2 Encoder connection			

CN1 Motor Connection

Motor connector for connection of the motor phases and the holding brake.

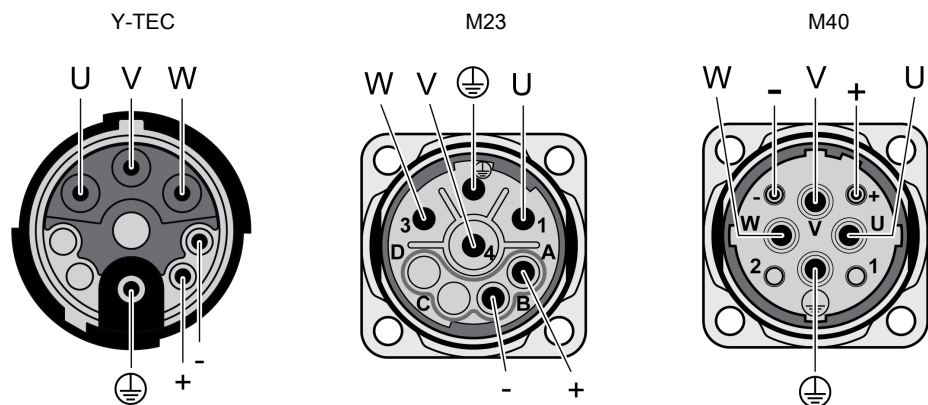

See chapter Connectors ([see page 85](#)) for suitable mating connectors.

The signals of the holding brake meet the PELV requirements.

Pin	Meaning	Accessory cable Wire color and wire number
U	Motor phase U	BK, L1
V	Motor phase V	BK, L2
W	Motor phase W	BK, L3
PE	Protective ground conductor	GN/YE
+	Supply voltage holding brake 24 Vdc	WH or BK 5
-	Reference potential holding brake 0 Vdc	GY or BK 6
SHLD	Shield (to connector housing)	-

CN2 encoder connection Y-TEC

Encoder connector for connection of the SinCos encoder (singleturn and multiturn)

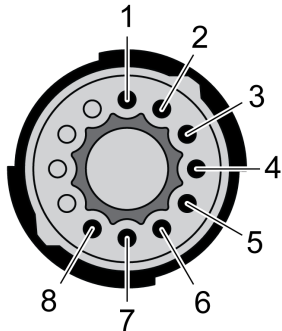

See chapter Connectors (*see page 85*) for suitable mating connectors.

The signals meet the PELV requirements.

Pin	Signal	Meaning	Pair ¹⁾	Accessory cable Wire color
1	COS_OUT	Cosine signal	2	GN
2	REFCOS_OUT	Reference for cosine signal, 2.5V	2	YE
3	SIN_OUT	Sine signal	1	WH
4	REFSIN_OUT	Reference for sine signal, 2.5 V	1	BN
5	DATA+	Receive data, transmit data	3	GY
6	DATA-	Receive data and transmit data, inverted	3	PK
7	ENC+10V	7 ... 12 V supply voltage	4	RD
8	ENC_0V	Reference potential ²⁾	4	BL
	SHLD	Shield (to connector housing)		

1) Signal pairs must be twisted
 2) The ENC_0V connection of the supply voltage has no connection to the encoder housing.

CN2 encoder connection M23

Encoder connector for connection of the SinCos encoder (singleturn and multiturn)

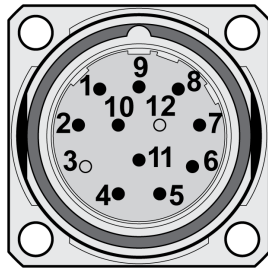

See chapter Connectors (*see page 85*) for suitable mating connectors.

The signals meet the PELV requirements.

Pin	Signal	Meaning	Pair ¹⁾	Accessory cable Wire color
1	PTC	Temperature sensor	6	BK
2	PTC	Temperature sensor	5	GY/PK
4	REFSIN_OUT	Reference for sine signal, 2.5 V	3	BN
5	REFCOS_OUT	Reference for cosine signal, 2.5V	2	YE
6	DATA+	Receive data, transmit data	1	GY
7	DATA-	Receive data and transmit data, inverted	1	PK
8	SIN_OUT	Sine signal	3	WH
9	COS_OUT	Cosine signal	2	GN
10	ENC+10V	7 ... 12 V supply voltage	4	RD
11	ENC_0V	Reference potential ²⁾	4	BL
	SHLD	Shield (to connector housing)		

1) Signal pairs must be twisted
2) The ENC_0V connection of the supply voltage has no connection to the encoder housing.

Motor connection terminal box

Terminal box for connection of the motor phases and the holding brake

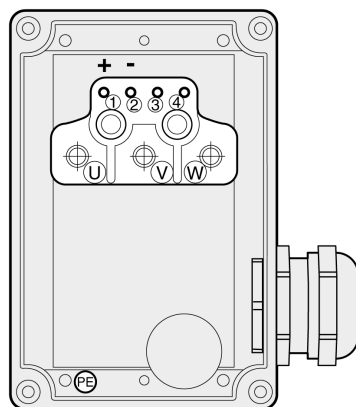

The signals of the holding brake meet the PELV requirements.

Pin	Assignment	Meaning
U	U	Motor phase U
	PE	Protective ground conductor
W	W	Motor phase W
V	V	Motor phase V
1	BR+	Supply voltage holding brake 24 Vdc
2	BR-	Reference potential holding brake
3	Reserved	Reserved
4	Reserved	Reserved
	SHLD	Shield (on housing)

Power and Encoder Connection

High voltages may be present at the motor connection. The motor itself generates voltage when the motor shaft is rotated. AC voltage can couple voltage to unused conductors in the motor cable.

⚠ DANGER

ELECTRIC SHOCK

- Verify that no voltage is present prior to performing any type of work on the drive system.
- Block the motor shaft to prevent rotation prior to performing any type of work on the drive system.
- Insulate both ends of unused conductors of the motor cable.
- Only touch the motor shaft or the mounted output components if all power has been disconnected.
- Verify compliance with all local and national electrical code requirements as well as all other applicable regulations with respect to grounding of all equipment.

Failure to follow these instructions will result in death or serious injury.

The motor is designed for operation via a drive. Connecting the motor directly to AC voltage will damage the motor and can cause fires and initiate an explosion.

⚠ DANGER

POTENTIAL FOR EXPLOSION

Only connect the motor to a matching, approved drive in the way described in the present documentation.

Failure to follow these instructions will result in death or serious injury.

Drive systems may perform unintended movements if unapproved combinations of drive and motor are used. Even if motors are similar, different adjustment of the encoder system may be a source of hazards. Even if the connectors for motor connection and encoder connection match mechanically, this does not imply that the motor is approved for use.

⚠ WARNING

UNINTENDED MOVEMENT

Only use approved combinations of drive and motor.

Failure to follow these instructions can result in death, serious injury, or equipment damage.

See chapter Approved Drives ([see page 22](#)) for approved drives.

Protective Ground Conductor Connection

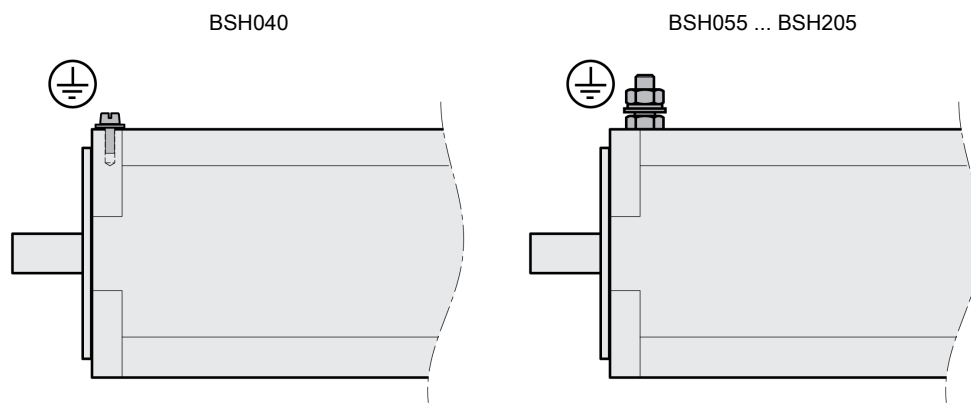

Ground the motor via a grounding screw if grounding via the flange and the protective ground conductor of the motor cable is not sufficient. Use parts with suitable corrosion protection. Note the required tightening torque and the property class of the grounding screw, see chapter Tightening Torque and Property Class Of Screws Used ([see page 19](#)).

Assembling Cables

Insulate unused wires individually.

- Note the EMC requirements for motor cables and encoder cables, see chapter Electromagnetic Compatibility (EMC) (*see page 55*).
- Use equipotential bonding conductors for equipotential bonding.

Assembling Motor Cables With Y-TEC Motor Connector (VW3M8219)

Refer to the Assembly Instructions for series 915 of Intercontec

www.intercontec.com

Assembling Motor Cables With M23 Motor Connector (VW3M8215)

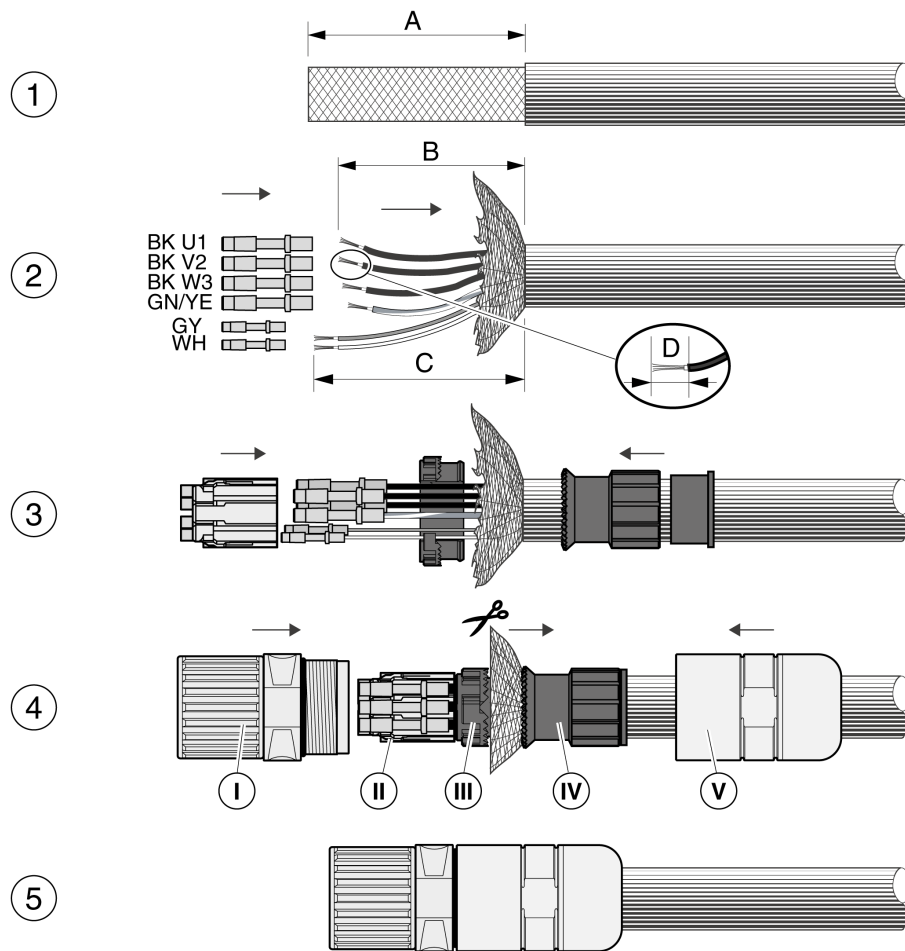

Step	Action
1	Strip the cable jacket. <ul style="list-style-type: none"> ● Stripping length A: 40 mm (1.57 in)
2	Open the shielding braid and slide it back over the outer cable jacket. Shorten the inner cable jacket. Shorten the wires to the specified length and crimp them to the connector. If possible, also connect unused wires. This improves EMC. Wires that are not connected must be insulated at both ends. <ul style="list-style-type: none"> ● Stripping length B: 36 mm (1.42 in) ● Stripping length C: 40 mm (1.57 in) ● Stripping length D: 8 mm (0.31 in) for motor phases; 4.5 mm (0.18 in) for holding brake ● Crimp contact: SF-7QS2000 for motor phases; SF-6AS2000 for holding brake ● Crimp tool: SF-Z0025
3	Push part (V) and part (IV) onto the cable. Snap the contacts into part (II). Open the side of part (III) and enclose the wires using this part.
4	Slide part (III) behind the shielding braid and insert part (II) into part (I). Arrange the shielding braid as shown. Push part (I) and part (III) together and shorten the shielding braid.
5	Screw part (IV) onto part (I) all the way to the stop.

Assembling Motor Cables With M40 Motor Connector (VW3M8217 and VW3M8218)

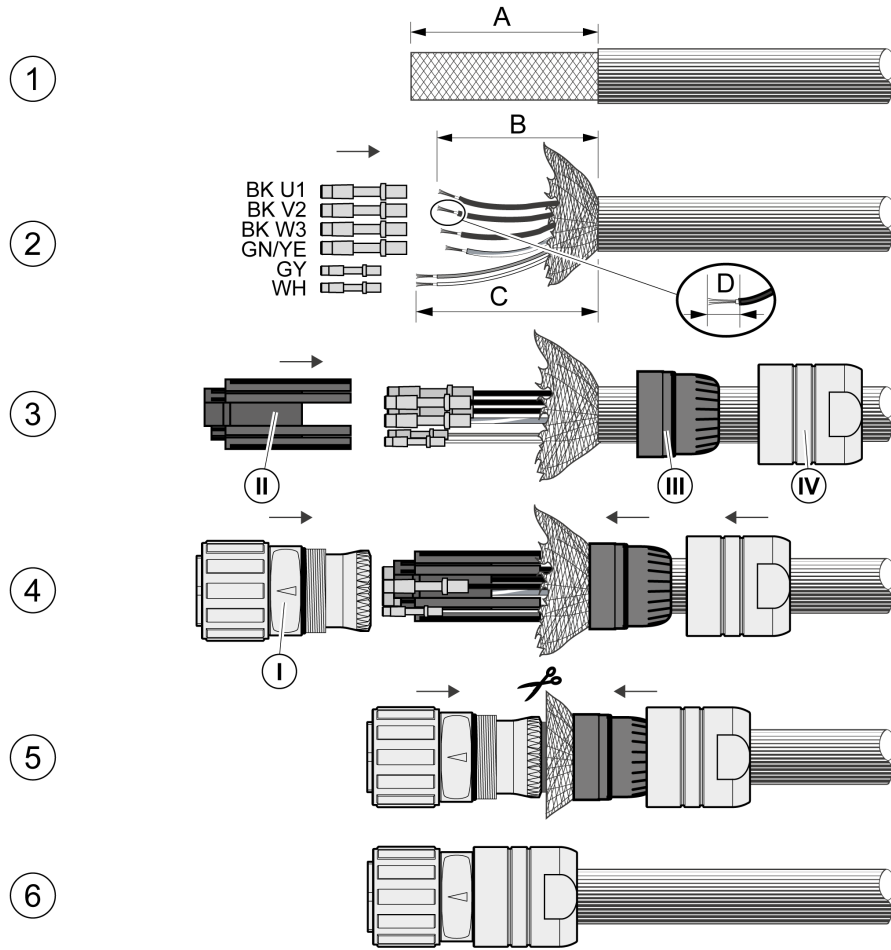

Step	Action
1	Strip the cable jacket. <ul style="list-style-type: none"> • Stripping length A: 40 mm (1.57 in)
2	Open the shielding braid and slide it back over the outer cable jacket. Shorten the inner cable jacket. Shorten the wires to the specified length and crimp them to the connector. If possible, also connect unused wires. This improves EMC. Wires that are not connected must be insulated at both ends. <ul style="list-style-type: none"> • Stripping length B: 36 mm (1.42 in) • Stripping length C: 40 mm (1.57 in) • Stripping length D: 10 mm (0.39 in) for motor phases; 4.5 mm (0.18 in) for holding brake • Crimp contact: SM-36KS002 for 4 mm² motor phases; SM-36KS004 for 6 mm² and 10 mm² motor phases; SF-7NS2000 for holding brake • Crimp tool: SF-Z0025 for 4 mm² motor phases and holding brake; SF-Z0026 for 6 mm² and 10 mm² motor phases
3	Push part (IV) and part (III) onto the cable. Snap the contacts laterally into part (II).
4	Slide part (III) behind the shielding braid and insert part (II) into part (I).
5	Arrange the shielding braid as shown. Push part (I) and part (III) together and shorten the shielding braid.
6	Screw part (IV) onto part (I) all the way to the stop.

Assembling Encoder Cables With Y-TEC Encoder Connector (VW3M8220)

Refer to the Assembly Instructions for series 615 of Intercontec

www.intercontec.com

Assembling Encoder Cables With M23 Encoder Connector (VW3M8214)

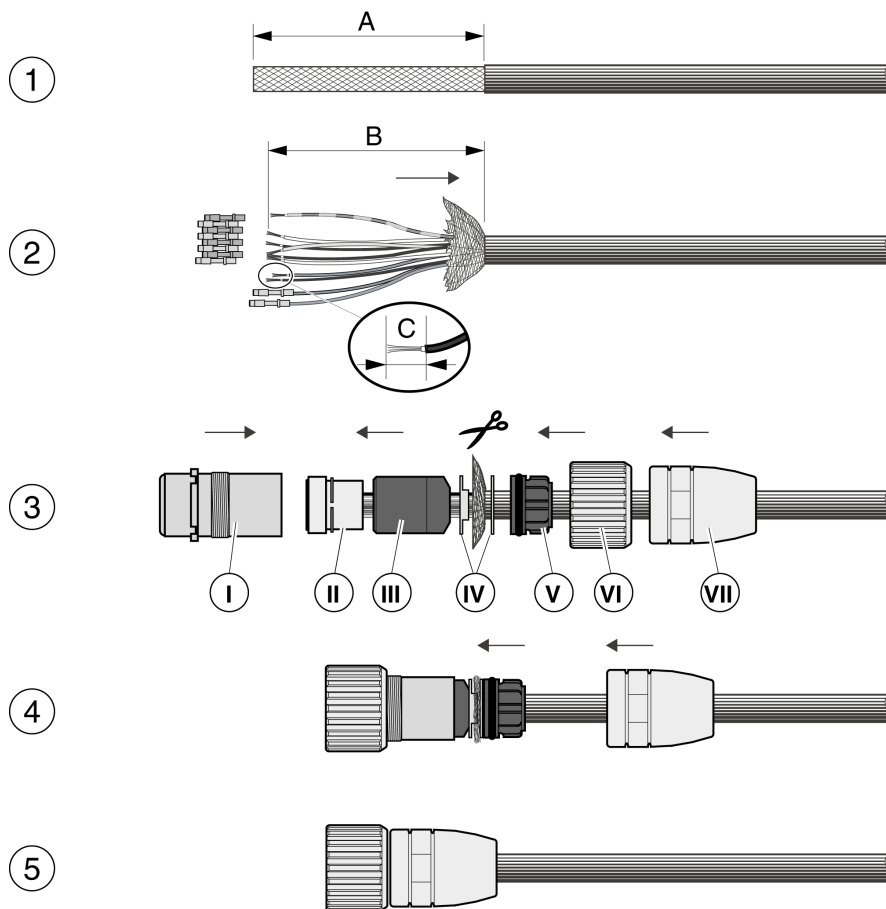

Step	Action
1	Strip the cable jacket. <ul style="list-style-type: none"> ● Stripping length A: 28 mm (1.1 in)
2	Open the shielding braid and slide it back over the outer cable jacket. Shorten the inner cable jacket. Shorten the wires to the specified length (see table below) and crimp them to the connector. If possible, also connect unused wires. This improves EMC. Wires that are not connected must be insulated at both ends. <ul style="list-style-type: none"> ● Stripping length B: 28 mm (1.1 in) ● Stripping length C: 4.5 mm (0.18 in) ● Crimp contact: RC-12S2000 ● Crimp tool: RC-Z2514
3	Push part (VII) and part (VI) onto the cable. The cable entry contains rubber seals of various sizes for different cable diameters. Use rubber seals matching the diameter of the cable. Enclose the shield with part (IV). Snap the contacts into part (II). Open part (III) at the side and enclose part (II) as well as the rear part of the contacts with it. Slide part (II) into part (I).
4	Slide part (IV) behind the shielding braid. Slide part (VI) over part (I).
5	Screw part (IV) onto part (I) all the way to the stop.

Connecting the Cables

Incorrect installation of the cable may damage the insulation. Broken conductors in the cable or improperly connected connectors may promote arcing within the cable.

DANGER

ELECTRIC SHOCK, ARC FLASH AND FIRE

- Disconnect all power before plugging in or unplugging the connectors.
- Verify correct pin assignment of the connectors according to the specifications in this chapter before connecting the cables.
- Verify that the connectors are properly inserted and locked before applying power.
- Avoid forces or movements of the cable at the cable entries.

Failure to follow these instructions will result in death or serious injury.

- Place the female connector of the motor cable onto the motor connector and tighten the union nut. Proceed in the same manner with the connection cable of the encoder system. Keep the connection cables from being twisted when tightening the union nut.
- Connect the motor cable and the encoder cable to the drive according to the wiring diagram of the drive.
- Ground the shield to a large surface area. See the product manual of the drive for information on connecting the shield.

Holding Brake Connection

Applying the holding brake while the motor is running will cause excessive wear and loss of the braking force.

WARNING

LOSS OF BRAKING FORCE DUE TO WEAR OR HIGH TEMPERATURE

- Do not use the holding brake as a service brake.
- Do not exceed the maximum number of brake applications and the kinetic energy during braking of moving loads.

Failure to follow these instructions can result in death, serious injury, or equipment damage.

See chapter Holding Brake (*see page 51*) for technical data on braking while the load moves.

Releasing the holding brake can cause an unintended movement, for example, lowering of the load in the case of vertical axes.

WARNING

UNINTENDED MOVEMENT

- Verify that there are no persons or obstacles in the zone of operation when performing a test of the holding brake.
- Take appropriate measures to avoid damage caused by falling or lowering loads or other unintended movements.

Failure to follow these instructions can result in death, serious injury, or equipment damage.

If the voltage is incorrect, the holding brake cannot be released which causes wear. If the voltage is higher than the specified voltage, the holding brake may be re-applied. If the voltage polarity is incorrect, the holding brake cannot be released.

WARNING

MISOPERATION OF THE HOLDING BRAKE CAUSED BY INCORRECT VOLTAGE

- Verify that the specified voltage is available at the holding brake connection.
- Use a properly rated voltage-sensing device for measuring.

Failure to follow these instructions can result in death, serious injury, or equipment damage.

A motor with a holding brake requires a suitable holding brake controller which releases the brake when the power stage is enabled and locks the motor shaft when the power stage is disabled.

Chapter 4

Commissioning

Commissioning

DANGER

ELECTRIC SHOCK OR UNINTENDED EQUIPMENT OPERATION

- Keep foreign objects (such as chips, screws or wire clippings) from getting into the product.
- Verify the correct seating of seals and cable entries in order to avoid contamination such as deposits and humidity.

Failure to follow these instructions will result in death or serious injury.

Drive systems may perform unanticipated movements because of incorrect connection or other errors.

WARNING

UNINTENDED MOVEMENT

- Verify proper wiring.
- Only start the system if there are no persons or obstructions in the zone of operation.
- Perform the first test runs without coupled loads.
- Only touch the motor shaft or the mounted output components if all power has been disconnected.

Failure to follow these instructions can result in death, serious injury, or equipment damage.

Drive systems may perform unintended movements if unapproved combinations of drive and motor are used. Even if motors are similar, different adjustment of the encoder system may be a source of hazards. Even if the connectors for motor connection and encoder connection match mechanically, this does not imply that the motor is approved for use.

WARNING

UNINTENDED MOVEMENT

Only use approved combinations of drive and motor.

Failure to follow these instructions can result in death, serious injury, or equipment damage.

See chapter Approved Drives ([see page 22](#)) for a list of approved drives.

Rotating parts may cause injuries and may catch clothing or hair. Loose parts or parts that are out of balance may be ejected.

WARNING

MOVING, UNGUARDED EQUIPMENT

Verify that rotating parts cannot cause injuries or equipment damage.

Failure to follow these instructions can result in death, serious injury, or equipment damage.

The metal surfaces of the product may exceed 70 °C (158 °F) during operation.

 WARNING
<p>HOT SURFACES</p> <ul style="list-style-type: none"> ● Avoid unprotected contact with hot surfaces. ● Do not allow flammable or heat-sensitive parts in the immediate vicinity of hot surfaces. ● Verify that the heat dissipation is sufficient by performing a test run under maximum load conditions. <p>Failure to follow these instructions can result in death, serious injury, or equipment damage.</p>

Motors can generate strong local electrical and magnetic fields. This can cause interference in electromagnetically sensitive devices.

 WARNING
<p>ELECTROMAGNETIC FIELDS</p> <ul style="list-style-type: none"> ● Keep persons with electronic medical implants, such as pacemakers, away from the motor. ● Do not place electromagnetically sensitive devices in the vicinity of the motor. <p>Failure to follow these instructions can result in death, serious injury, or equipment damage.</p>

 WARNING
<p>IMPROPER APPLICATION OF FORCES</p> <ul style="list-style-type: none"> ● Do not use the motor as a step to climb into or onto the machine. ● Do not use the motor as a load-bearing part. ● Use hazard labels and guards on your machine to help prevent the improper application of forces on the motor. <p>Failure to follow these instructions can result in death, serious injury, or equipment damage.</p>

Prior to commissioning, verify correct installation.

Step	Action
1	Verify proper mechanical installation.
2	Verify proper electrical installation. <ul style="list-style-type: none"> ● Did you connect all protective ground conductors? ● Did you properly connect and install all cables and connectors? ● Did you tighten the cable glands properly?
3	Verify that the ambient conditions are met. <ul style="list-style-type: none"> ● Does the installation meet the ambient conditions specified?
4	Verify the output components. <ul style="list-style-type: none"> ● Have the installed output components been balanced and accurately aligned?
5	Verify the parallel key at the shaft end of the motor. <ul style="list-style-type: none"> ● If you have a motor with a parallel key groove and parallel key, the parallel key must not be inserted during commissioning without output component or it must be appropriately secured.
6	Verify the function of the holding brake. <ul style="list-style-type: none"> ● Is the holding brake able to hold the maximum load? ● Is the holding brake released prior to the start of a movement?

NOTE: Observe the information on commissioning in the product manual of the drive.

Chapter 5

Diagnostics and Troubleshooting

What Is in This Chapter?

This chapter contains the following topics:

Topic	Page
Mechanical Issues	82
Electrical Issues	82

Mechanical Issues

Issue	Cause	Troubleshooting
Excessive heat	Overload	Reduce load
	Holding brake not released	Verify that the holding brake controller operates properly
	Heavy pollution	Clean the motor
Whistling or knocking noise	Rolling bearings	Contact your sales office
Grinding noise	Rotating output component grinds	Align output component
Radial oscillation	Poor alignment of output component	Align output component
	Output component out of balance	Balance output component
	Shaft bent	Contact your sales office
	Resonance with machine bed	Suppress resonance
Axial oscillation	Poor alignment of output component	Align output component
	Damage to the output component	Repair/replace output component
	Resonance with machine bed	Suppress resonance

Electrical Issues

Issue	Cause	Solution
Motor does not start or has difficulty starting	Overload	Reduce load.
	Unsuitable settings for the drive	Correct drive settings.
	Cable damaged	Replace damaged cables.
Excessive heat	Overload	Reduce power.
Heat at the terminals or connectors	Poor contact	Tighten the terminals / connectors with the specified tightening torque.

Chapter 6

Accessories and Spare Parts

What Is in This Chapter?

This chapter contains the following topics:

Topic	Page
IP67 Kit	84
Connectors	85
Motor Cables	86
Encoder Cables	89

IP67 Kit

Degree of protection IP65 (shaft sealing ring) is a prerequisite for the use of the IP67 kit.

Hardware version \geq RS02:

Description	Reference
IP67 kit for size 055, cover with compressed air connection, O-ring, 4 screws	VW3M2300
IP67 kit for size 070, cover with compressed air connection, O-ring, 4 screws	VW3M2301
IP67 kit for size 100, cover with compressed air connection, O-ring, 4 screws	VW3M2302
IP67 kit for size 140, cover with compressed air connection, O-ring, 4 screws	VW3M2303
IP67 kit for size 205, cover with compressed air connection, O-ring, 4 screws	VW3M2304

Hardware version $<$ RS02:

Description	Reference
IP67 kit for size 055, cover with compressed air connection, O-ring, 4 screws	VW3M2305
IP67 kit for size 070, cover with compressed air connection, O-ring, 4 screws	VW3M2306
IP67 kit for size 100, cover with compressed air connection, O-ring, 4 screws	VW3M2307
IP67 kit for size 140, cover with compressed air connection, O-ring, 4 screws	VW3M2308
IP67 kit for size 205, cover with compressed air connection, O-ring, 4 screws	VW3M2304

Connectors

Description	Reference
Connector for motor cable, motor side Y-TEC, 1 mm ² , 5 pcs	VW3M8219
Connector for motor cable, motor side M23, 1.5 ... 2.5 mm ² , 5 pcs	VW3M8215
Connector for motor cable, motor side M40, 4 mm ² , 5 pcs	VW3M8217
Connector for motor cable, motor side M40, 6...10 mm ² , 5 pcs	VW3M8218
Connector for encoder cable, motor side Y-TEC, 5 pcs	VW3M8220
Connector for encoder cable, motor side M23, 5 pcs	VW3M8214
Connector for encoder cable, drive side RJ45 (10 pins), 5 pcs	VW3M2208

The tools required for cable assembly can be ordered directly from the manufacturer.

- Crimping tool for power connector Y-TEC:
Intercontec C0.201.00 or C0.235.00
www.intercontec.com
- Crimping tool for power connector M23/M40:
Coninvers SF-Z0025, SF-Z0026
www.coninvers.com
- Crimping tool for encoder connector Y-TEC:
Intercontec C0.201.00 or C0.235.00
www.intercontec.com
- Crimping tool for encoder connector M23:
Coninvers RC-Z2514
www.coninvers.com
- Crimping tools for encoder connector RJ45 10 pins:
Yamaichi Y-ConTool-11, Y-ConTool-20, Y-ConTool-30
www.yamaichi.com

Motor Cables

Motor Cables 1.0 mm²

Description	Reference
Motor cable 3 m (9.84 ft), (4 x 1.0 mm ² + 2 x (2 x 0.75 mm ²)) shielded; motor end 8-pin circular connector Y-TEC, other cable end open	VW3M5100R30
Motor cable 5 m (16.4 ft), (4 x 1.0 mm ² + 2 x (2 x 0.75 mm ²)) shielded; motor end 8-pin circular connector Y-TEC, other cable end open	VW3M5100R50
Motor cable 10 m (32.8 ft), (4 x 1.0 mm ² + 2 x (2 x 0.75 mm ²)) shielded; motor end 8-pin circular connector Y-TEC, other cable end open	VW3M5100R100
Motor cable 15 m (49.2 ft), (4 x 1.0 mm ² + 2 x (2 x 0.75 mm ²)) shielded; motor end 8-pin circular connector Y-TEC, other cable end open	VW3M5100R150
Motor cable 25 m (82 ft), (4 x 1.0 mm ² + 2 x (2 x 0.75 mm ²)) shielded; motor end 8-pin circular connector Y-TEC, other cable end open	VW3M5100R250
Motor cable 100 m (328 ft), (4 x 1.0 mm ² + 2 x (2 x 0.75 mm ²)) shielded; both cable ends open	VW3M5300R1000

Motor Cables 1.5 mm²

Description	Reference
Motor cable 1.5 m (4.92 ft), (4 x 1.5 mm ² + (2 x 1 mm ²)) shielded; motor end 8-pin circular connector M23, other cable end open	VW3M5101R15
Motor cable 3 m (9.84 ft), (4 x 1.5 mm ² + (2 x 1 mm ²)) shielded; motor end 8-pin circular connector M23, other cable end open	VW3M5101R30
Motor cable 5 m (16.4 ft), (4 x 1.5 mm ² + (2 x 1 mm ²)) shielded; motor end 8-pin circular connector M23, other cable end open	VW3M5101R50
Motor cable 10 m (32.8 ft), (4 x 1.5 mm ² + (2 x 1 mm ²)) shielded; motor end 8-pin circular connector M23, other cable end open	VW3M5101R100
Motor cable 15 m (49.2 ft), (4 x 1.5 mm ² + (2 x 1 mm ²)) shielded; motor end 8-pin circular connector M23, other cable end open	VW3M5101R150
Motor cable 20 m (65.6 ft), (4 x 1.5 mm ² + (2 x 1 mm ²)) shielded; motor end 8-pin circular connector M23, other cable end open	VW3M5101R200
Motor cable 25 m (82 ft), (4 x 1.5 mm ² + (2 x 1 mm ²)) shielded; motor end 8-pin circular connector M23, other cable end open	VW3M5101R250
Motor cable 50 m (164 ft), (4 x 1.5 mm ² + (2 x 1 mm ²)) shielded; motor end 8-pin circular connector M23, other cable end open	VW3M5101R500
Motor cable 75 m (246 ft), (4 x 1.5 mm ² + (2 x 1 mm ²)) shielded; motor end 8-pin circular connector M23, other cable end open	VW3M5101R750
Motor cable 25 m (82 ft), (4 x 1.5 mm ² + (2 x 1 mm ²)) shielded; both cable ends open	VW3M5301R250
Motor cable 50 m (164 ft), (4 x 1.5 mm ² + (2 x 1 mm ²)) shielded; both cable ends open	VW3M5301R500
Motor cable 100 m (328 ft), (4 x 1.5 mm ² + (2 x 1 mm ²)) shielded; both cable ends open	VW3M5301R1000

Motor Cables 2.5 mm²

Description	Reference
Motor cable 3 m (9.84 ft), (4 x 2.5 mm ² + (2 x 1 mm ²)) shielded; motor end 8-pin circular connector M23, other cable end open	VW3M5102R30
Motor cable 5 m (16.4 ft), (4 x 2.5 mm ² + (2 x 1 mm ²)) shielded; motor end 8-pin circular connector M23, other cable end open	VW3M5102R50
Motor cable 10 m (32.8 ft), (4 x 2.5 mm ² + (2 x 1 mm ²)) shielded; motor end 8-pin circular connector M23, other cable end open	VW3M5102R100
Motor cable 15 m (49.2 ft), (4 x 2.5 mm ² + (2 x 1 mm ²)) shielded; motor end 8-pin circular connector M23, other cable end open	VW3M5102R150

Description	Reference
Motor cable 20 m (65.6 ft), (4 x 2.5 mm ² + (2 x 1 mm ²)) shielded; motor end 8-pin circular connector M23, other cable end open	VW3M5102R200
Motor cable 25 m (82 ft), (4 x 2.5 mm ² + (2 x 1 mm ²)) shielded; motor end 8-pin circular connector M23, other cable end open	VW3M5102R250
Motor cable 50 m (164 ft), (4 x 2.5 mm ² + (2 x 1 mm ²)) shielded; motor end 8-pin circular connector M23, other cable end open	VW3M5102R500
Motor cable 75 m (246 ft), (4 x 2.5 mm ² + (2 x 1 mm ²)) shielded; motor end 8-pin circular connector M23, other cable end open	VW3M5102R750
Motor cable 25 m (82 ft), (4 x 2.5 mm ² + (2 x 1 mm ²)) shielded; both cable ends open	VW3M5302R250
Motor cable 50 m (164 ft), (4 x 2.5 mm ² + (2 x 1 mm ²)) shielded; both cable ends open	VW3M5302R500
Motor cable 100 m (328 ft), (4 x 2.5 mm ² + (2 x 1 mm ²)) shielded; both cable ends open	VW3M5302R1000

Motor Cables 4 mm²

Description	Reference
Motor cable 3 m (9.84 ft), (4 x 4 mm ² + (2 x 1 mm ²)) shielded; motor end 8-pin circular connector M40, other cable end open	VW3M5103R30
Motor cable 5 m (16.4 ft), (4 x 4 mm ² + (2 x 1 mm ²)) shielded; motor end 8-pin circular connector M40, other cable end open	VW3M5103R50
Motor cable 10 m (32.8 ft), (4 x 4 mm ² + (2 x 1 mm ²)) shielded; motor end 8-pin circular connector M40, other cable end open	VW3M5103R100
Motor cable 15 m (49.2 ft), (4 x 4 mm ² + (2 x 1 mm ²)) shielded; motor end 8-pin circular connector M40, other cable end open	VW3M5103R150
Motor cable 20 m (65.6 ft), (4 x 4 mm ² + (2 x 1 mm ²)) shielded; motor end 8-pin circular connector M40, other cable end open	VW3M5103R200
Motor cable 25 m (82 ft), (4 x 4 mm ² + (2 x 1 mm ²)) shielded; motor end 8-pin circular connector M40, other cable end open	VW3M5103R250
Motor cable 50 m (164 ft), (4 x 4 mm ² + (2 x 1 mm ²)) shielded; motor end 8-pin circular connector M40, other cable end open	VW3M5103R500
Motor cable 75 m (246 ft), (4 x 4 mm ² + (2 x 1 mm ²)) shielded; motor end 8-pin circular connector M40, other cable end open	VW3M5103R750
Motor cable 25 m (82 ft), (4 x 4 mm ² + (2 x 1 mm ²)) shielded; both cable ends open	VW3M5303R250
Motor cable 50 m (164 ft), (4 x 4 mm ² + (2 x 1 mm ²)) shielded; both cable ends open	VW3M5303R500
Motor cable 100 m (328 ft), (4 x 4 mm ² + (2 x 1 mm ²)) shielded; both cable ends open	VW3M5303R1000

Motor Cables 6 mm²

Description	Reference
Motor cable 3 m (9.84 ft), (4 x 6 mm ² + (2 x 1 mm ²)) shielded; motor end 8-pin circular connector M40, other cable end open	VW3M5105R30
Motor cable 5 m (16.4 ft), (4 x 6 mm ² + (2 x 1 mm ²)) shielded; motor end 8-pin circular connector M40, other cable end open	VW3M5105R50
Motor cable 10 m (32.8 ft), (4 x 6 mm ² + (2 x 1 mm ²)) shielded; motor end 8-pin circular connector M40, other cable end open	VW3M5105R100
Motor cable 15 m (49.2 ft), (4 x 6 mm ² + (2 x 1 mm ²)) shielded; motor end 8-pin circular connector M40, other cable end open	VW3M5105R150
Motor cable 20 m (65.6 ft), (4 x 6 mm ² + (2 x 1 mm ²)) shielded; motor end 8-pin circular connector M40, other cable end open	VW3M5105R200
Motor cable 25 m (82 ft), (4 x 6 mm ² + (2 x 1 mm ²)) shielded; motor end 8-pin circular connector M40, other cable end open	VW3M5105R250

Description	Reference
Motor cable 50 m (164 ft), (4 x 6 mm ² + 2 x 1 mm ²) shielded; motor end 8-pin circular connector M40, other cable end open	VW3M5105R500
Motor cable 75 m (246 ft), (4 x 6 mm ² + 2 x 1 mm ²) shielded; motor end 8-pin circular connector M40, other cable end open	VW3M5105R750
Motor cable 25 m (82 ft), (4 x 6 mm ² + 2 x 1 mm ²) shielded; both cable ends open	VW3M5305R250
Motor cable 50 m (164 ft), (4 x 6 mm ² + 2 x 1 mm ²) shielded; both cable ends open	VW3M5305R500
Motor cable 100 m (328 ft), (4 x 6 mm ² + 2 x 1 mm ²) shielded; both cable ends open	VW3M5305R1000

Encoder Cables

Description	Reference
Encoder cable 3 m (9.84 ft), (3 x 2 x 0.14 mm ² + 2 x 0.34 mm ²) shielded; motor end 12-pin circular connector Y-TEC, device end 10-pin connector RJ45	VW3M8100R30
Encoder cable 5 m (16.4 ft), (3 x 2 x 0.14 mm ² + 2 x 0.34 mm ²) shielded; motor end 12-pin circular connector Y-TEC, device end 10-pin connector RJ45	VW3M8100R50
Encoder cable 10 m (32.8 ft), (3 x 2 x 0.14 mm ² + 2 x 0.34 mm ²) shielded; motor end 12-pin circular connector Y-TEC, device end 10-pin connector RJ45	VW3M8100R100
Encoder cable 15 m (49.2 ft), (3 x 2 x 0.14 mm ² + 2 x 0.34 mm ²) shielded; motor end 12-pin circular connector Y-TEC, device end 10-pin connector RJ45	VW3M8100R150
Encoder cable 25 m (82 ft), (3 x 2 x 0.14 mm ² + 2 x 0.34 mm ²) shielded; motor end 12-pin circular connector Y-TEC, device end 10-pin connector RJ45	VW3M8100R250
Encoder cable 1.5 m (4.92 ft), (3 x 2 x 0.14 mm ² + 2 x 0.34 mm ²) shielded; motor end 12-pin circular connector M23, device end 10-pin connector RJ45	VW3M8102R15
Encoder cable 3 m (9.84 ft), (3 x 2 x 0.14 mm ² + 2 x 0.34 mm ²) shielded; motor end 12-pin circular connector M23, device end 10-pin connector RJ45	VW3M8102R30
Encoder cable 5 m (16.4 ft), (3 x 2 x 0.14 mm ² + 2 x 0.34 mm ²) shielded; motor end 12-pin circular connector M23, device end 10-pin connector RJ45	VW3M8102R50
Encoder cable 10 m (32.8 ft), (3 x 2 x 0.14 mm ² + 2 x 0.34 mm ²) shielded; motor end 12-pin circular connector M23, device end 10-pin connector RJ45	VW3M8102R100
Encoder cable 15 m (49.2 ft), (3 x 2 x 0.14 mm ² + 2 x 0.34 mm ²) shielded; motor end 12-pin circular connector M23, device end 10-pin connector RJ45	VW3M8102R150
Encoder cable 20 m (65.6 ft), (3 x 2 x 0.14 mm ² + 2 x 0.34 mm ²) shielded; motor end 12-pin circular connector M23, device end 10-pin connector RJ45	VW3M8102R200
Encoder cable 25 m (82 ft), (3 x 2 x 0.14 mm ² + 2 x 0.34 mm ²) shielded; motor end 12-pin circular connector M23, device end 10-pin connector RJ45	VW3M8102R250
Encoder cable 50 m (164 ft), (3 x 2 x 0.14 mm ² + 2 x 0.34 mm ²) shielded; motor end 12-pin circular connector M23, device end 10-pin connector RJ45	VW3M8102R500
Encoder cable 75 m (246 ft), (3 x 2 x 0.14 mm ² + 2 x 0.34 mm ²) shielded; motor end 12-pin circular connector M23, device end 10-pin connector RJ45	VW3M8102R750
Encoder cable 25 m (82 ft), (3 x 2 x 0.14 mm ² + 2 x 0.34 mm ²) shielded; both cable ends open	VW3M8222R250
Encoder cable 50 m (164 ft), (3 x 2 x 0.14 mm ² + 2 x 0.34 mm ²) shielded; both cable ends open	VW3M8222R500
Encoder cable 100 m (328 ft), (3 x 2 x 0.14 mm ² + 2 x 0.34 mm ²) shielded; both cable ends open	VW3M8222R1000

Chapter 7

Service, Maintenance, and Disposal

What Is in This Chapter?

This chapter contains the following topics:

Topic	Page
Service Addresses	92
Maintenance	92
Replacing the Motor	94
Shipping, Storage, Disposal	95

Service Addresses

Schneider Electric Automation GmbH

Schneiderplatz 1
97828 Marktheidenfeld, Germany
Phone: +49 (0) 9391 / 606 - 0
Fax: +49 (0) 9391 / 606 - 4000
Email: info-marktheidenfeld@schneider-electric.com
Internet: <http://www.schneider-electric.com>

Machine Solutions Service

Schneiderplatz 1
97828 Marktheidenfeld, Germany
Phone: +49 (0) 9391 / 606 - 3265
Fax: +49 (0) 9391 / 606 - 3340
Email: automation.support.de@schneider-electric.com
Internet: <http://www.schneider-electric.com>

Additional Contact Addresses

See the homepage for additional contact addresses:
<http://www.schneider-electric.com>

Maintenance

Maintenance Plan

There are no user-serviceable parts within the motor.
Either replace the complete motor, or contact Schneider Electric.
The product may only be repaired by a Schneider Electric customer service center.

WARNING

UNINTENDED EQUIPMENT OPERATION

- Only use software and hardware components approved by Schneider Electric for use with this equipment.
- Do not attempt to service this equipment outside of authorized Schneider Electric service centers.
- Update your application program every time you change the physical hardware configuration.

Failure to follow these instructions can result in death, serious injury, or equipment damage.

Use only the accessories and mounting parts specified in the documentation and no third-party devices or components that have not been expressly approved by Schneider Electric. Do not modify the equipment.
Include the following points in the maintenance plan of your machine.

Connections and Fastening

- Inspect all connection cables and connectors regularly for damage. Replace damaged cables immediately.
- Verify regularly that all output elements are firmly seated.
- Verify regularly that all mechanical and electrical threaded connections are tightened to the specified torque.

Lubricating the Shaft Sealing Ring

In the case of motors with shaft sealing ring, lubricant must be applied to the space between the sealing lip of the shaft sealing ring and the shaft with a suitable non-metallic tool. If the shaft sealing rings are allowed to run dry, the service life of the shaft sealing rings will be significantly reduced.

Cleaning

If the permissible environmental conditions are not respected, external substances from the environment may penetrate the product and cause unintended movement or equipment damage.

⚠ WARNING

UNINTENDED MOVEMENT

- Verify that the environmental conditions are respected.
- Do not allow seals to run dry.
- Keep liquids from getting to the shaft bushing (for example, in mounting position IM V3).
- Do not expose the shaft sealing rings and cable entries of the motor to the direct spray of a pressure washer.

Failure to follow these instructions can result in death, serious injury, or equipment damage.

Clean dust and dirt off the product at regular intervals. Insufficient heat dissipation to the ambient air may excessively increase the temperature.

Motors are not suitable for cleaning with a pressure washer. The high pressure may force water into the motor.

Care must be taken with cleaning products as some active agents may have deleterious effects on plastics and welds. When using solvents or cleaning agents, verify that the cables, cable entry seals, O-rings and motor paint are not damaged.

NOTICE

CORROSION CAUSED BY CLEANING AGENTS

- Before using a cleaning agent, carry out a compatibility test in relation to the cleaning agent and the component affected.
- Do not use alkaline cleaning agents.
- Do not use cleaning agents containing chloride.
- Do not use cleaning agents containing sulfuric acid.

Failure to follow these instructions can result in equipment damage.

Inspecting/Breaking In the Holding Brake

The holding brake is broken-in at the factory. If the holding brake is not used for an extended period of time, parts of the holding brake may corrode. Corrosion reduces the holding torque.

If the holding brake does not have the holding torque indicated in the technical data, it must be broken in again.

- If the motor is mounted, dismount the motor.
- Measure the holding torque of the holding brake using a torque wrench.
- If the holding torque of the holding brake considerably differs from the specified values, manually rotate the motor shaft by 25 rotations in both directions. See chapter Holding Brake (*see page 51*) for the values.
- Repeat the process up to 3 times, until you can restore the original holding torque.
Contact your Schneider Electric sales office if the original holding torque is not restored.

Replacing the Rolling Bearing

When the rolling bearing is replaced, the motor is partially demagnetized and loses power.

NOTICE

INOPERABLE EQUIPMENT

Do not replace the rolling bearing.

Failure to follow these instructions can result in equipment damage.

For all service matters, contact your Schneider Electric representative.

Replacing the Motor

If you replace the motor, the absolute position of the encoder is no longer valid.

WARNING

UNINTENDED MOVEMENT DUE TO INCORRECT ABSOLUTE POSITION

Set the new absolute position of the encoder after having replaced the motor.

Failure to follow these instructions can result in death, serious injury, or equipment damage.

Step	Action
1	Power off all supply voltages. Verify that no voltages are present.
2	Label all connections and uninstall the product.
3	Note the identification number and the serial number shown on the product nameplate for later identification.
4	Install the new product as per chapter Installation (<i>see page 53</i>).
5	Commission the product as per chapter Commissioning (<i>see page 79</i>).

Shipping, Storage, Disposal

Shipping

The product must be protected against shocks during transportation. If possible, use the original packaging for shipping.

Storage

The product may only be stored in spaces where the specified permissible ambient conditions are met. Protect the product from dust and dirt.

Disposal

The product consists of various materials that can be recycled. Dispose of the product in accordance with local regulations.

Visit <http://www.schneider-electric.com/green-premium> for information and documents on environmental protection as per ISO 14025 such as:

- EoLi (Product End-of-Life Instructions)
- PEP (Product Environmental Profile)



A

Axial forces

Tension or compression forces acting longitudinally on the shaft

C

Centering collar

Centering device at the motor flange that allows for accurate motor mounting.

D

Degree of protection

The degree of protection is a standardized specification for electrical equipment that describes the protection against the ingress of foreign objects and water (for example: IP 20).

DOM

Date of manufacturing: The nameplate of the product shows the date of manufacture in the format DD.MM.YY or in the format DD.MM.YYYY. For example:

31.12.11 corresponds to December 31, 2011

31.12.2011 corresponds to December 31, 2011

Drive system

System consisting of controller, drive and motor.

E

EMC

Electromagnetic compatibility

L

Length

In the type code, the length is defined in terms of the number of stacks.

P

PELV

Protective Extra Low Voltage, low voltage with isolation. For more information: IEC 60364-4-41

R

Radial forces

Forces that act radially on the shaft

S

Size

In the type code, the size is defined in terms of the flange size.



A

Approved drives, *22*

C

cable specifications, *60*

D

disposal, *95, 95*

E

EMC, *55*

 Motor cable and encoder cable, *55*

Encoder, *49*

Encoder cable

 EMC requirements, *55*

Equipotential bonding conductors, *56*

F

force for pressing on, *34*

G

general characteristics, *18*

H

holding brake, *51*

holding brake connection, *77*

I

Installation, *53*

M

maintenance, *92*

Motor cable

 EMC requirements, *55*

mounting position, *63*

N

nameplate, *13*

R

Replacing the motor, *94*

S

SEK37 Singleturn, *50*

SEL37 Multiturn, *50*

service addresses, *92*

shaft load, *34*

shaft-specific data, *34*

shipping, *95*

SKM36 Multiturn, *49*

SKS36 Singleturn, *49*

storage, *95*

T

type code, *15*

