

# SLP-KONSTANTER 32N

Series SLP 120 / SLP 240 / SLP 320

Analog Controlled Laboratory Power Supplies

13025  
11/5.15

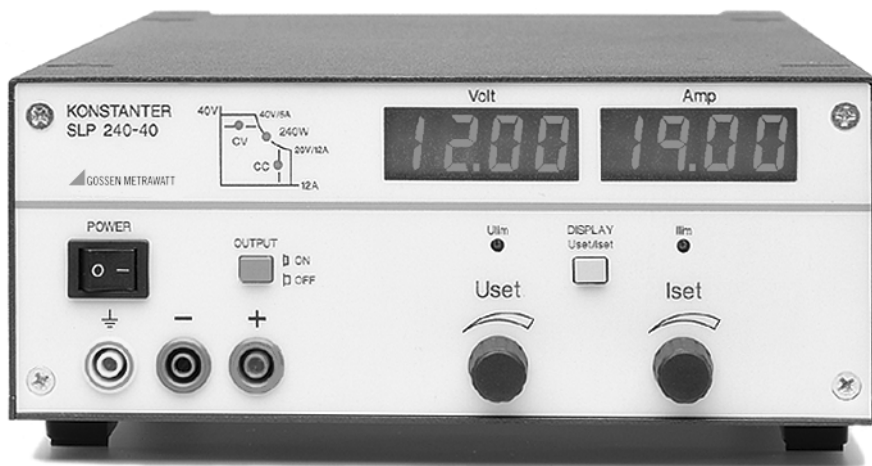



# Contents

	Page
Receiving Inspection . . . . .	4
Warnings and Safety Precautions . . . . .	4
Important Warnings . . . . .	4
1 Technical Description . . . . .	5
1.1 Range of Applications and Features . . . . .	5
1.2 Functional Characteristics . . . . .	5
1.3 Options and Accessories . . . . .	5
1.4 Technical Data . . . . .	6
1.4.1 General Data . . . . .	6
1.4.2 Electrical Data . . . . .	7
1.4.3 Mechanical Data . . . . .	10
2 Preparation for Operation and Initial Start-Up . . . . .	11
2.1 Connection to the Mains . . . . .	11
2.2 Connection to the Consuming Device . . . . .	11
2.3 Sensing Mode Operation . . . . .	11
2.4 Installation to a 19" Rack . . . . .	12
2.5 Multiple Benchtop Device Combination . . . . .	12
3 Controls, Displays and Connectors . . . . .	13
4 Adjusting Output Values . . . . .	15
4.1 Output Voltage . . . . .	15
4.1.1 $U_{out}$ – Presently Measured Voltage Value . . . . .	15
4.1.2 $U_{lim}$ – Limit Value for $U_{set}$ . . . . .	15
4.1.3 $U_{set}$ – Voltage Setpoint Value . . . . .	15
4.2 Output Current . . . . .	16
4.2.1 $I_{out}$ – Presently Measured Current Value . . . . .	16
4.2.2 $I_{lim}$ – Limit Value for $I_{set}$ . . . . .	16
4.2.3 $I_{set}$ – Current Setpoint Value . . . . .	16
4.3 OUTPUT – Switching the Power Output On and Off . . . . .	16
5 Control via the Analog Interface . . . . .	17
5.1 Connector Assignments . . . . .	17
5.2 Status Signal Outputs . . . . .	18
5.3 Trigger Input . . . . .	18
5.4 Controlling Output Voltage . . . . .	19
5.5 Controlling Output Current . . . . .	19
5.6 Voltage Monitoring Output . . . . .	20
5.7 Current Monitoring Output . . . . .	20
5.8 Parallel Operation . . . . .	21
5.8.1 Direct Parallel Operation . . . . .	21
5.8.2 Parallel Master-Slave Operation . . . . .	22
5.9 Series Operation . . . . .	23
5.9.1 Direct Series Operation . . . . .	23
5.9.2 Series Master-Slave Operation . . . . .	24
5.10 Varying Internal Output Resistance . . . . .	25
6 Accessories . . . . .	26
7 Order Information . . . . .	26
8 Repair and Replacement Parts Service Calibration Center and Rental Service . . . . .	26
9 Product Support . . . . .	26

## Receiving Inspection

Immediately upon receipt, unpack the **KONSTANTER** and all included accessories, and inspect for completeness and possible damage.

### Unpacking

- ☞ Other than the usual degree of care required for the handling of electronic devices, no special care must be exercised when unpacking the instrument.
- ☞ The **KONSTANTER** is shipped in recyclable packaging which provides for adequate protection during transport. If the instrument needs to be repacked, the original packaging, or equivalent packaging, must be used.

### Visual Inspection

- ☞ Compare the order number or type designation found on the packaging and/or the serial plate with the specifications printed in the shipping documents.
- ☞ Make sure that all accessory components have been included (→ 1.3 Options and Accessories).
- ☞ Inspect the packaging as well as instrument mechanisms for possible transport damage.

### Complaints

If damage is detected, file a damages report immediately with the freight forwarder (save the packaging!). In the event of any other defects or if service is required, please contact your service representative, or contact us directly at the address included in the last page of these instructions.

## Warnings and Safety Precautions

The **KONSTANTER** has been manufactured and tested in accordance with the safety regulations specified in the technical data section included in this chapter as a safety class I device. It has left the factory in flawless technical safety conditions. In order to maintain this condition, and to assure safe use, the user must observe all notes and warnings included in these operating instructions. These are identified with the following headings:

### CAUTION!

**Operating instructions or practical information etc., which must be observed in order to prevent damage to the KONSTANTER, and to assure correct operation.**

### WARNING!

**Operating instructions or practical information etc., which must be observed in order to maintain the safety features included with the KONSTANTER, and to prevent personal injury.**

**The most important warnings are summarized below. Reference is made to these warning at all appropriate points throughout the operating instructions.**

## Important Warnings

### WARNING I – Protective Ground

The **KONSTANTER** may only be operated with a connected protective conductor. Any interruption of the protective conductor, either inside or outside of the **KONSTANTER** or disconnection of the protective conductor terminal, may render the **KONSTANTER** hazardous. Intentional interruption is prohibited.

Mains connection is accomplished with a 3-conductor cable with mains plug. The plug may only be inserted into a suitable mains outlet with an earthing contact. The resulting protection must not be rendered ineffective through the use of an extension cable without protective conductor.

### WARNING II – Impaired Safety Protection

If it may be assumed that safe operation is no longer possible, the **KONSTANTER** must be removed from service and secured against unintentional use. It must be assumed that safe operation is no longer possible if:

- The **KONSTANTER** demonstrates visible damage
- The **KONSTANTER** no longer functions
- After lengthy periods of storage if specified storage conditions have not been observed
- After excessive stress due to transport

### WARNING III – Opening Housing Covers

Voltage conducting part may be exposed when housing covers are opened, as long as the **KONSTANTER** is connected.

Touching these exposed voltage conducting parts is extremely life endangering.

Housing covers may thus only be opened or removed by qualified personnel who are familiar with the dangers involved.

### WARNING IV – Repairs Performed by Qualified Personnel Only

Voltage conducting part may be exposed when housing covers are opened, as long as the **KONSTANTER** is connected.

Maintenance and repairs, as well as internal instrument balancing, may only be performed by qualified personnel who are familiar with the dangers involved.

In as far as possible, the **KONSTANTER** must be disconnected from all external voltage sources before such work is performed. A 5 minute waiting period must be observed after disconnection, in order to allow internal capacitors to discharge to safe voltage levels.

### WARNING V – Replacing Fuses

When replacing blown fuses, use only specified fuse types with the specified current ratings (see technical data or serial plate).

Tampering with the fuses or fuse holders (“mending” fuses, short-circuiting fuse holders etc.) is prohibited.

# 1 Technical Description

## 1.1 Range of Applications and Features

The **SLP-KONSTANTER** is a single channel laboratory power supply for universal use in R&D, production, training and service.

The **KONSTANTER** maintains either **constant current or constant voltage** and is capable of delivering 120 W or 240 W of nominal power over a broad range thanks to the auto-ranging output.

Precise manual settings for voltage and current are accomplished with the help of ten-turn potentiometers. The setting range can be reduced with a screwdriver, in order to prevent inadvertent adjustment to unwanted, excessively high values.

Output voltage and current appear at **two large-format 3½ place digital LED displays**, which can also be switched for the display of **setpoint values**. **Control mode displays** indicate the respective operating status.

The **floating output at the front and rear panels** can be activated and deactivated by pressing a key, or with a signal to the analog interface which is provided as standard equipment. The instrument is **automatically** switched to **remote sensing** as soon as sensor cables are connected.

The sturdy metal housing is sealed at top and bottom, and is equipped with rubber feet and a cable spacer at the rear panel.

With a minimum of effort, several housings can be mechanically combined into a **multi-channel unit**. This unit requires only one mains outlet which is looped through with the help of a mains jumper cable (accessory) via the integrated **mains outlet socket**. Installation to a 19" rack is also possible with the appropriate adapter.

## 1.2 Functional Characteristics

### Adjustable functions

- Voltage and current setpoints
- Limit values for voltage and current setting ranges
- Output activation and deactivation

### Display functions

- Measured voltage and current values
- Voltage and current setpoints
- Current control mode (CC/CV)

### Protective and additional functions

- Reverse polarity protection for sensor terminals with automatic activation (auto-sensing)
- Protection against excessive temperature
- Protection against output polarity reversal
- In-rush current limiting
- Temperature controlled fan
- Master-slave link

## 1.3 Options and Accessories

### Options

No options are available for the **KONSTANTER**, above and beyond the included standard equipment.

### Included Accessories:

The following accessories are included with the **KONSTANTER**:

- These operating instructions
- 1 power cable (approx. 1.5 m long) with earthing contact plug

### Additionally available accessories:

(see last page for order information)

- 19" adapter (1x32N) for installing 1 series SLP **KONSTANTER** to a 19" rack
- 19" adapter (2x32N) for installing 2 series SLP **KONSTANTERs** to a 19" rack
- Mains jumper cable, 0.4 m long used for looping through mains power, equipped with a 10 A plug and a 10 A socket for non-heating apparatus

## 1.4 Technical Data

### 1.4.1 General Data

#### Power Supply

Connection	Input: 10 A IEC plug Output: 10 A IEC socket, no switch, no fuse
Line Voltage	230 V~, +10 / -15%, 47 ... 63 Hz
Power Consumption	see 1.4.2
In-Rush Current	max. 50 A <sub>S</sub>
Mains Fuse	1 x T 4 A / 250 V (6.3 x 32 mm, UL) internal: 1 x T 5 H / 250 V (5 x 20 mm)

#### Output

Connection	front panel, 2 ea. 4 mm safety socket
Output	rear panel, 6-pole plug-in screw terminal block
Sensor	rear panel, 6-pole plug-in screw terminal block

Regulator Type	primary switched mode with BET technology
Operating Modes	adjustable constant voltage / constant current source with automatic sharp transition
Output Isolation	Floating output with "safety isolation" from the mains input, max. allowed potential output-earth: 120 V, capacitive output-earth (housing): 60 nF

#### Output Working Range

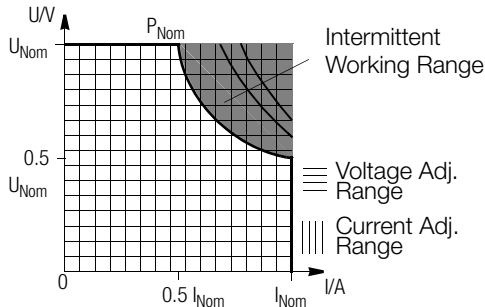

**Intermittent Working Range:**  
Overtemperature protection may be triggered, and the output deactivated, if operated for lengthy periods of time in the intermittent working range (see also intermittent power, 1.4.2).

#### Analog Interface

Connection	11-pole plug-in screw terminal block
Reference Potential	negative output pole, floating TRG input

#### Connector Pin Assignments:

Pin	Designation	Function
1	SIG1 OUT	Status signal output for output ON/OFF (open collector, max. 30 V - / 20 mA)
2	SIG2 OUT	Control mode status signal output CV / CC (open collector, max. 30 V - / 20 mA)
3	TRG IN +	Digital control input for output ON/OFF (low: < 1 V, high: 4 ... 26 V), floating
4	TRG IN -	
5	+15 V	Auxiliary voltage +15 V / max. 50 mA
6	AGND	Reference point connected to - output via automatic resetting fuse
7	U <sub>set</sub> -	Analog, negated voltage control input (0 ... -5 V corres. to 0 ... U <sub>nom</sub> , R <sub>i</sub> = 10 kΩ)
8	U <sub>set</sub> +	Analog voltage control input (0 ... +5 V corres. to 0 ... U <sub>nom</sub> , R <sub>i</sub> = 10 kΩ)
9	I <sub>set</sub> +	Analog current control input (0 ... +5 V corres. to 0 ... I <sub>nom</sub> , R <sub>i</sub> = 10 kΩ)

10	U-MON	Output voltage measurement output (0 ... 10 V corres. to 0 ... U <sub>nom</sub> , R <sub>i</sub> = 9.8 kΩ)
11	I-MON	Output current measurement output (0 ... 10 V corres. to 0 ... I <sub>nom</sub> , R <sub>i</sub> = 9.4 kΩ)

#### Electrical Safety

Safety class	I
Overvoltage category	II for mains input I for output and interfaces
Fouling factor	2
Earth leakage current	2.5 mA, typ.

IEC 61010-1:1990 + A1:1992 / DIN EN 61010-1: 1993 / VDE 0411-1:1994

DIN VDE 0160:1988 + A1:1989 class W1

EN 60950:1992 / VDE 0805:1990

Protection IP 20 for housing per IEC 529:1989, EN 60529:1991, VDE 0470-1:1992

Electrical isolation Test voltage  
Mains/output-PE 1.35 kV~  
Mains-output 2.7 kV~ (type test: 3.7 kV ~)

#### Electromagnetic Compatibility (EMC)

Product standard	EN 61326-1:1997 + A1: 1998
Interference emission	EN 55022:1998 class A
Interference immunity	EN 61000-4-2:1995, feature A EN 61000-4-3:1996 + A1:1998, feature B EN 61000-4-4:1995, feature B EN 61000-4-5:1995, feature B EN 61000-4-6:1996, feature B EN 61000-4-11:1994, feature B

#### Ambient Conditions

IEC 68-2-6 ('90)	Resistance to Vibration (10 ... 55 Hz, 0.3 mm, 1 octave / min, 3 x 30 min)
IEC 68-2-27 ('89)	Impact Resistance (15 g, 11 ms, half-sine, 3 x 6 shocks)
Temperature Range	Operation: 0 ... 50 °C current derating at > 40 °C (see also 1.4.2.) Storage: -25 ... +75 °C
Atmospheric Humidity	Operation: ≤ 75% relative humidity, no condensation
Cooling	With integrated fan Air inlet: at side panels Air outlet: at rear panel

## 1.4.2 Electrical Data

### Electrical Data, Series 120 W

If not otherwise specified, all entries are maximum values and are valid for an operating temperature range of 0 to 50 °C, nominal power range and a line voltage range of 230 V ± 10% after a warm-up period of 30 minutes.

Description (abbreviated designation)		SLP 120-20	SLP 120-40	SLP 120-80
<b>Type</b>		<b>32 N 20 R 10</b>	<b>32 N 40 R 6</b>	<b>32 N 80 R 3</b>
<b>Nominal Output Data</b>				
Voltage setting range		0 ... 20 V	0 ... 40 V	0 ... 80 V
Current setting range		0 ... 10 A	0 ... 6 A	0 ... 3 A
Continuous power where $T_u \leq 40$ °C		max. 120 W	max. 120 W	max. 120 W
Intermittent power where $t < 90$ s / $T_u \leq 25$ °C		max. 200 W	max. 240 W	max. 240 W
Current derating where $T_u > 40$ °C		-0.25 A / K	-0.15 A / K	-0.07 A / K
<b>Output Operating Characteristics</b>				
Overall setting accuracy at $23 \pm 5$ °C with reference to 3½ place setpoint display including system deviation, load / mains		Voltage 0.2% + 50 mV Current 0.5% + 45 mA	0.2% + 150 mV 0.5% + 35 mA	0.2% + 250 mV 0.5% + 20 mA
Static system deviation <sup>1)</sup> at 100% load variation <sup>1)</sup>		Voltage 15 mV Current 20 mA	10 mV 10 mA	10 mV 10 mA
Static system deviation <sup>1)</sup> at 10% line voltage variation <sup>1)</sup>		Voltage 5 mV Current 8 mA	5 mV 5 mA	5 mV 5 mA
Residual ripple <sup>1)</sup> $U_a > 5\% U_{nom}$		Voltage (10 Hz ... 10 MHz) 10 mV <sub>eff</sub> Current (10 Hz ... 1 MHz) 25 mA <sub>eff</sub>	10 mV <sub>eff</sub> 20 mA <sub>eff</sub>	10 mV <sub>eff</sub> 10 mA <sub>eff</sub>
Common-mode noise (10 Hz ... 1 MHz)		0.5 mA <sub>eff</sub>	0.5 mA <sub>eff</sub>	0.5 mA <sub>eff</sub>
Settling time (voltage) with sudden load variation of 10 ... 90% $I_{nom}$		Tolerance 40 mV (Typical values) $\Delta I = 80\%$ 200 µs	80 mV 200 µs	80 mV 200 µs
Under and overshooting with sudden load variation of 50 A / ms		(Typical values) $\Delta I = 80\%$ 400 mV	400 mV	800 mV
Settling time (voltage) with setpoint jump: 0 → 100% with setpoint jump: 100% → 0		Tolerance no load / nominal load no load / nominal load 40 mV 1 ms / 1 ms 1 ms / 1 ms	80 mV 1 ms / 1 ms 1 ms / 1 ms	160 mV 4 ms / 4ms 4 ms / 4ms
Settling time (current) with setpoint jump: 0 → 100% with setpoint jump: 100% → 0		Tolerance short-circuit / nominal load short-circuit / nominal load 100 mA < 5 ms / < 5 ms < 5 ms / < 5 ms	60 mA < 5 ms / < 5 ms < 5 ms / < 5 ms	30 mA < 10 ms / < 10 ms < 10 ms / < 10 ms
<b>Measured Value Displays (3½ place)</b>				
Measurement resolution		Voltage 10 mV Current 10 mA	100 mV 10 mA	100 mV 10 mA
Measuring accuracy at $23 \pm 5$ °C with reference to the respective measured value		Voltage 0.15% + 25 mV Current 0.5% + 30 mA	0.2% + 120 mV 0.5% + 25 mA	0.2% + 150 mV 0.5% + 20 mA
<b>Protective Functions</b>				
Output overvoltage protection		Threshold 25 ± 1 V	50 ± 2 V	100 ± 4 V
Reversed polarity protection – overload capacity		Continuous 10 A	6 A	3 A
Reverse flow resistance		Continuous 40 V	80 V	100 V
<b>General</b>				
Power supply <sup>1)</sup>		Line voltage 230 V~ +10 / -15% 47 ... 63 Hz	230 V~ +10 / -15% 47 ... 63 Hz	230 V~ +10 / -15% 47 ... 63 Hz
Power Consumption		At nominal load In standby mode At max. intermittent power 280 VA, 180 W 45 VA, 15 W 450 VA	280 VA, 150 W 45 VA, 15 W 500 VA	280 VA, 170 W 45 VA, 15 W 500 VA
Efficiency		At nominal load > 70%	> 80%	> 80%
Switching frequency		Typical 200 kHz	200 kHz	200 kHz
<b>Article number</b>		<b>K220A</b>	<b>K221A</b>	<b>K222A</b>

1) Typical values are increased by a factor of approximately 1.2 in the functional line voltage input range of -10% to -15%.

## Electrical Data, Series 240 W

If not otherwise specified, all entries are maximum values and are valid for an operating temperature range of 0 to 50 °C, nominal power range and a line voltage range of 230 V ± 10% after a warm-up period of 30 minutes.

Description (abbreviated designation)		SLP 240-20	SLP 240-40	SLP 240-80
Type		32 N 20 R 20	32 N 40 R 12	32 N 80 R 6
<b>Nominal Output Data</b>	Voltage setting range	0 ... 20 V	0 ... 40 V	0 ... 80 V
	Current setting range	0 ... 20 A	0 ... 12 A	0 ... 6 A
	Continuous power where $T_u \leq 40$ °C	max. 240 W	max. 240 W	max. 240 W
	Intermittent power where $t < 90$ s / $T_u \leq 25$ °C	max. 320 W	max. 360 W	max. 360 W
	Current derating where $T_u > 40$ °C	- 0.5 A / K	- 0.3 A / K	- 0.15 A / K
<b>Output Operating Characteristics</b>				
Overall setting accuracy at $23 \pm 5$ °C with reference to 3½ place setpoint display including system deviation, load / mains	Voltage	0.2% + 100 mV	0.2% + 150 mV	0.2% + 250 mV
	Current	0.5% + 55 mA	0.5% + 45 mA	0.5% + 35 mA
Static system deviation <sup>1)</sup> at 100% load variation <sup>1)</sup>	Voltage	25 mV	18 mV	18 mV
	Current	30 mA	30 mA	15 mA
Static system deviation <sup>1)</sup> at 10% line voltage variation <sup>1)</sup>	Voltage	5 mV	5 mV	5 mV
	Current	8 mA	8 mA	5 mA
Residual ripple <sup>1)</sup> $U_a > 5\% U_{nom}$	Voltage (10 Hz ... 10 MHz)	15 mV <sub>eff</sub>	15 mV <sub>eff</sub>	15 mV <sub>eff</sub>
	Current (10 Hz ... 1 MHz)	50 mA <sub>eff</sub>	25 mA <sub>eff</sub>	20 mA <sub>eff</sub>
Common-mode noise (10 Hz ... 1 MHz)		0.5 mA <sub>eff</sub>	0.5 mA <sub>eff</sub>	0.5 mA <sub>eff</sub>
Settling time (voltage) with sudden load variation of 10 ... 90% $I_{nom}$	Tolerance	40 mV	80 mV	160 mV
	(Typical values) $\Delta I = 80\%$	600 µs	300 µs	200 µs
Under and overshooting with sudden load variation of 50 A / ms	(Typical values) $\Delta I = 80\%$	450 mV	450 mV	800 mV
Settling time (voltage) with setpoint jump: 0 → 100% with setpoint jump: 100% → 0	Tolerance no load / nominal load	40 mV 1 ms / 1 ms	80 mV 1 ms / 1 ms	160 mV 4 ms / 4ms
	no load / nominal load	1 ms / 1 ms	1 ms / 1 ms	4 ms / 4ms
Settling time (current) with setpoint jump: 0 → 100% with setpoint jump: 100% → 0	Tolerance short-circuit / nominal load	200 mA < 5 ms / < 5 ms	120 mA < 5 ms / < 5 ms	60 mA < 10 ms / < 10 ms
	short-circuit / nominal load	< 5 ms / < 5 ms	< 5 ms / < 5 ms	< 10 ms / < 10 ms
<b>Measured Value Displays (3½ place)</b>				
Measurement resolution	Voltage	10 mV	100 mV	100 mV
	Current	10 mA	10 mA	10 mA
Measuring accuracy at $23 \pm 5$ °C with reference to the respective measured value	Voltage	0.2% + 50 mV	0.2% + 120 mV	0.2% + 120 mV
	Current	0.5% + 25 mA	0.5% + 30 mA	0.5% + 25 mA
<b>Protective Functions</b>				
Output overvoltage protection	Threshold	25 ± 1 V	50 ± 2 V	100 ± 4 V
Reversed polarity protection – overload capacity	Continuous	20 A	12 A	6 A
Reverse flow resistance	Continuous	40 V	80 V	100 V
<b>General</b>				
Power supply <sup>1)</sup>	Line voltage	230 V~ +10 / -15% 47 ... 63 Hz	230 V~ +10 / -15% 47 ... 63 Hz	230 V~ +10 / -15% 47 ... 63 Hz
Power Consumption	At nominal load	510 VA, 350 W	500 VA, 340 W	500 VA, 340 W
	In standby mode	45 VA, 15 W	45 VA, 15 W	45 VA, 15 W
	At max. intermittent power	620 VA	690 VA	690 VA
Efficiency	At nominal load	> 68%	> 70%	> 70%
Switching frequency	Typical	200 kHz	200 kHz	200 kHz
<b>Article number</b>		<b>K230A</b>	<b>K231A</b>	<b>K232A</b>

1) Typical values are increased by a factor of approximately 1.2 in the functional line voltage input range of -10% to -15%.



## Electrical Data, Series 320 W

If not otherwise specified, all entries are maximum values and are valid for an operating temperature range of 0 to 50 °C, nominal power range and a line voltage range of 230 V ± 10% after a warm-up period of 30 minutes.

Description (abbreviated designation)		SLP 320-32	
Type		32 N 32 R 18	
<b>Nominal Output Data</b>	Voltage setting range	0 ... 32 V	
	Current setting range	0 ... 18 A	
	Continuous power where $T_u \leq 40$ °C	max. 320 W	
	Intermittent power where $t < 90$ s / $T_u \leq 25$ °C	max. 430 W	
	Current derating where $T_u > 40$ °C	– 0.5 A / K	
<b>Output Operating Characteristics</b>			
Overall setting accuracy at $23 \pm 5$ °C with reference to 3½ place setpoint display including system deviation, load / mains	Voltage	0.2% + 150 mV	
	Current	0.5% + 50 mA	
Static system deviation <sup>1)</sup> at 100% load variation <sup>1)</sup>	Voltage	30 mV	
	Current	40 mA	
Static system deviation <sup>1)</sup> at 10% line voltage variation <sup>1)</sup>	Voltage	10 mV	
	Current	20 mA	
Residual ripple <sup>1)</sup> $U_a > 5\% U_{nom}$	Voltage (10 Hz ... 10 MHz)	30 mV <sub>eff</sub>	
	Current (10 Hz ... 1 MHz)	50 mA <sub>eff</sub> ( $U_a > 10\% U_{nom}$ )	
Common-mode noise (10 Hz ... 1 MHz)		0.5 mA <sub>eff</sub>	
Settling time (voltage) with sudden load variation of 10 ... 90% $I_{nom}$	Tolerance	64 mV	
	(Typical values) $\Delta I = 80\%$	500 µs	
Under and overshooting with sudden load variation of 50 A / ms	(Typical values) $\Delta I = 80\%$	450 mV	
Settling time (voltage) with setpoint jump: 0 → 100% with setpoint jump: 100% → 0	Tolerance no load / nominal load	64 mV 1 ms / 1 ms	
	no load / nominal load	1 ms / 1 ms	
Settling time (current) with setpoint jump: 0 → 100% with setpoint jump: 100% → 0	Tolerance short-circuit / nominal load	180 mA < 5 ms / < 5 ms	
	short-circuit / nominal load	< 5 ms / < 5 ms	
<b>Measured Value Displays (3½ place)</b>			
Measurement resolution	Voltage	100 mV	
	Current	10 mA	
Measuring accuracy at $23 \pm 5$ °C with reference to the respective measured value	Voltage	0.2% + 120 mV	
	Current	0.5% + 40 mA	
<b>Protective Functions</b>			
Output overvoltage protection	Threshold	40 ± 1 V	
Reversed polarity protection – overload capacity	Continuous	20 A	
Reverse flow resistance	Continuous	64 V	
<b>General</b>			
Power supply <sup>1)</sup>	Line voltage	230 V~ +10 / –15% 47 ... 63 Hz	
Power Consumption	At nominal load	650 VA, 460 W	
	In standby mode	50 VA, 15 W	
	At max. intermittent power	770 VA	
Efficiency	At nominal load	> 69%	
Switching frequency	Typical	200 kHz	
<b>Article number</b>	<b>K234A</b>		

1) Typical values are increased by a factor of approximately 1.2 in the functional line voltage input range of –10% to –15%.

### 1.4.3 Mechanical Data

#### Mechanical Design

Benchtop instrument, suitable for rack mounting

Dimensions

See also dimensional drawing

(W x H x D)

221.5 x 102 x 397.5 mm

For 19" rack

1/2 19" x 2 standard height units x 400 mm

Weight

approx. 2.8 kg

#### Dimensional Drawing

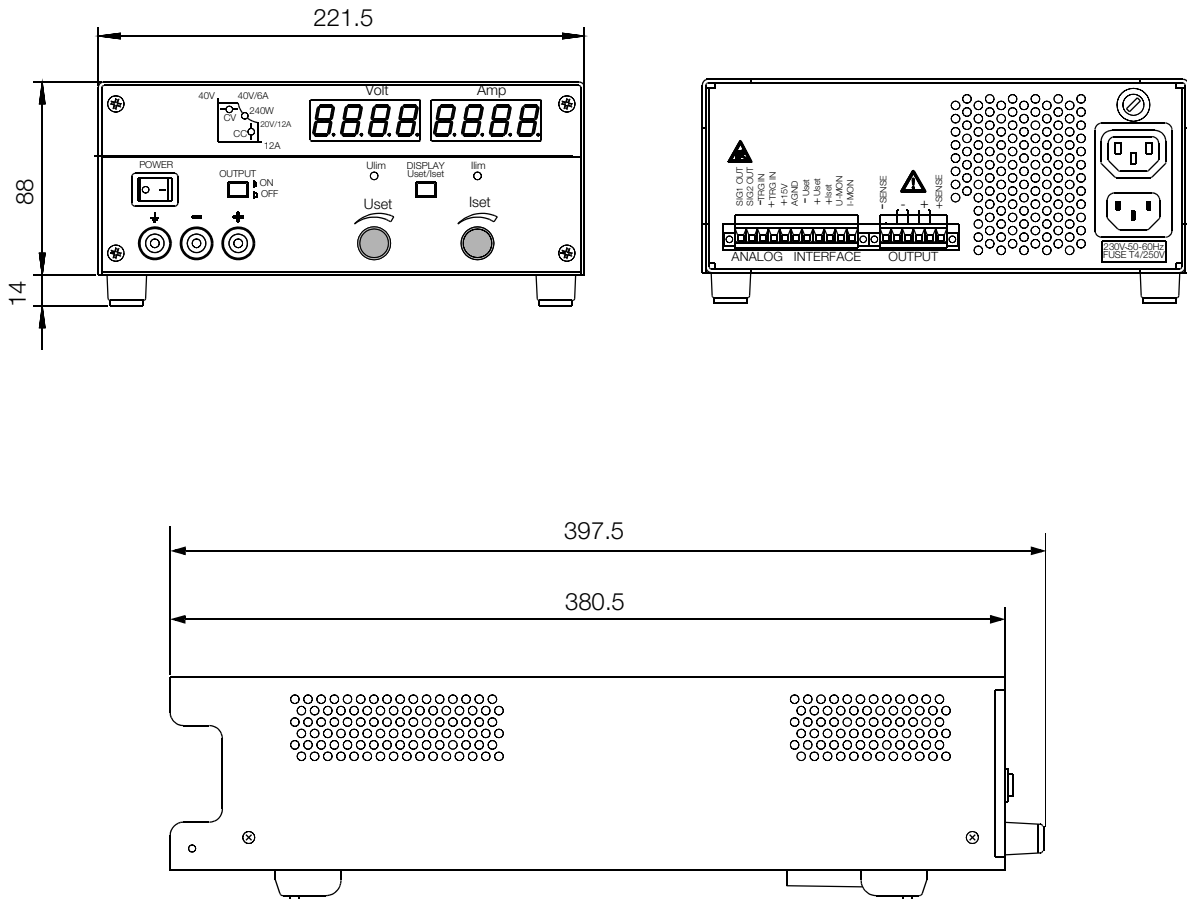

All dimensions in mm

## 2 Preparation for Operation and Initial Start-Up

### 2.1 Connection to the Mains

Observe **WARNING!**

#### CAUTION!

Before switching the KONSTANTER on, make sure that your local mains voltage corresponds with the operating voltage specified on the instrument's rear panel.

The KONSTANTER requires 230 V~ supply power. Connect the recessed mains plug at the back of the device to a mains outlet with earthing contact with the included power cable. Power consumption is specified on the serial plate at the back of the KONSTANTER.

A mains outlet socket is located above the recessed plug and can be used for looping mains power through to additional instruments.

This mains outlet is neither switched nor fused.

#### WARNING!

If mains power is looped through, make sure that overall power consumption does not exceed 10 A at the point from which power is drawn from the mains!

Suitable "mains jumper cables" are available as an accessory (see order information on last page).

### 2.2 Connection to the Consuming Device

Supply power to the consuming device is connected either at the front panel with 4 mm safety plugs to the safety jacks identified with the "+" and "-" markings, or to the "+" and "-" outputs at the 6-pole terminal strip at the rear panel.

Connections for the consuming device at the rear panel include two "+" and two "-" terminals.

These must be connected in parallel for load currents of greater than 10 A due to contact ratings.

Be certain to use conductors with an adequate cross-section and observe correct polarity. It is advisable to twist the power leads to the consuming device, and to identify polarity with markings at their ends.

If connections are made simultaneously at the front and the rear panel, constant voltage regulation applies to the terminals at the rear panel. This is **not permitted for parallel connection** because the internal connection might otherwise be overloaded.

The yellow-green safety jack at the front panel is connected to PE, and can be used to connect earthing cables or cable shields, or as an earth connection point for one of the output terminals.

### 2.3 Sensing Mode Operation

In order to take advantage of highly constant output voltage, even if long leads are used for connection to the consuming device, voltage drops at the power leads can be compensated for with additional sensing leads.

#### Function

- Sensing terminals: **+SENSE / -SENSE**  
Output voltage, which is decisive for the voltage measuring and regulating circuits, is acquired **directly at the consuming device** (instead of at the output terminals).
- Sensing mode operation (**remote sensing**) offers the following advantages:
  - ☞ **Voltage** at the consuming device remains largely **uninfluenced** by **current-dependent voltage drops** at the **power supply leads** during **constant voltage operation**.  
Voltage drops are **compensated for** by automatically

increasing voltage as required at the output jacks.

- ☞ **Voltage limiting** remains **uninfluenced** by **output current** as well during **constant current operation**.
- ☞ The **voltage value** determined by the measuring function corresponds to **voltage acquired by the sensing leads**. **Load parameters** such as **power consumption** and **load impedance** can thus be more precisely determined.
- The **parameters** and **limit values** listed in **figure 2.3** apply for operation with sensing leads.

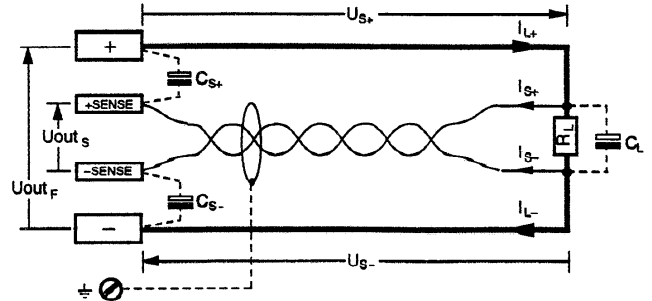

Figure 2.3 Connection to Consumer for Sensing Mode Operation

- $C_{S+}, C_{S-}$  typically ... 220  $\mu\text{F}$
- $U_{S+}, U_{S-} \leq 1 \text{ V}$
- $I_{S+} = U_{S+} / 81 \Omega$
- $I_{S-} = U_{S-} / 81 \Omega$

#### Connection

- The **+SENSE** and **-SENSE** leads from the **output plug connector at the rear panel** should be connected **as close as possible** to the corresponding terminals at the power consuming device.
- **Interference injection** can be minimized as follows:
  - ☞ **Twist** the sensing leads and/or
  - ☞ **Shield** the sensing leads.  
(Connect shield to ground/housing or neg. output terminal.)
- **Impedance resulting from long power and sensing leads** may lead to control oscillation at the output.  
**Capacitance at the consumer** promotes this problem as well.
- Control oscillation can be counteracted by connecting capacitors ( $C_{S+}, C_{S-}$ ) between the **SENSE** and the **output terminals** (see figure 2.3).
- **Twisting the power leads** reduces their impedance as well.
- **Incorrect connection of the sensing leads does not cause any damage to the KONSTANTER**, although it results in the following reversible events:
  - ☞ **Sensing lead polarity reversal or power lead interruption**  
If output voltage from the KONSTANTER is not limited with the current regulator, it rises to well above the setpoint value. **Overvoltage protection** is then immediately triggered and the **output is deactivated**.
  - ☞ **Sensing lead interruption**  
If one of the sensing leads is interrupted, the device is switched automatically to local sensing for the corresponding output terminal.
- If the sensing leads are connected incorrectly, voltage present at the output terminals or consuming device is not displayed.

#### Activating Sensing Mode Operation

- Sensing mode operation is activated **automatically after connecting** the SENSE terminal to the consumer which has been connected to the output terminals.
- Sensing mode operation is **deactivated** as soon as this connection has been **interrupted**.

## 2.4 Installation to a 19" Rack

The housing included with the **KONSTANTERs** has been designed for use as a benchtop device, as well as for installation to a 19" rack. Two **KONSTANTERs** can be installed next to one another, or a single device can be installed along with a blanking plate. Benchtop devices can be quickly converted for installation to a 19" rack.

### Installing a Single KONSTANTER to a 19" Rack

Use the 19" adapter set accessory 1x32N.

It includes an 19" limit stop and a ½19" blanking plate.

- ① Loosen the 4 screws at the front panel of the **KONSTANTER**.
- ② Pull out the two filler strips from the left and right-hand sides at the front of the side panels.

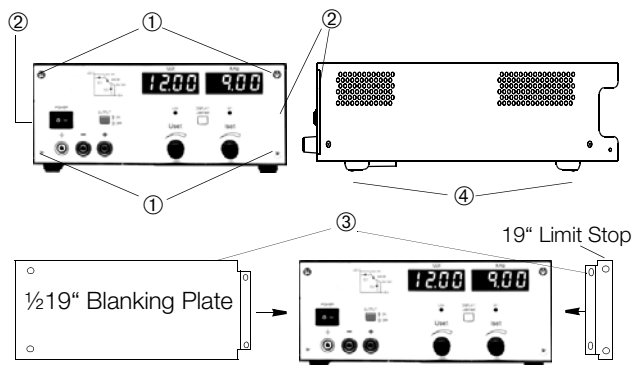

Figure 2.4 Rack Conversion for a Single Device

- ③ Replace the filler strips with the 19" limit stop on one side, and the ½19" blanking plate on the other side. Fasten the limit stop and the blanking plate with the 4 screws.
- ④ Unscrew the feet from the bottom of the device. Remove the rubber inserts from the feet first, behind which the screws are concealed.
- ⑤ Install the **KONSTANTER** into the rack. Keep all remaining parts in a safe place for possible future use.
- ⑥ The **KONSTANTER** must be supported in the rack **at one side with slide rails**. The slide rails, as well as the screws required for securing the **KONSTANTER's** front panel are rack-specific, and must thus be obtained **from your rack supplier**.

### Conversion for Installing Two KONSTANTERs to a 19" Rack

Use the 19" adapter set accessory 2x32N.

It includes two 19" limit stops and one 19" joiner.

- ① Loosen the 8 screws from the front panels at the **KONSTANTERs**.
- ② Pull out the two filler strips from the left and right-hand sides of the front of the side panels at each device.

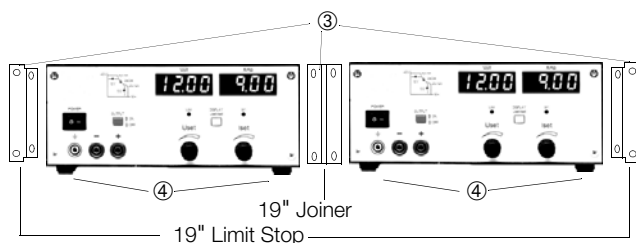

Figure 2.4 Rack Conversion for Two Devices

- ③ Replace the filler strips with the 19" limit stops at the right and left-hand sides, and with the 19" joiner in the middle. Fasten the limit stops and the joiner with the 8 screws. Screw the housings together at the threaded through-holes in the cable spacers at the back of the devices.
- ④ Unscrew the feet from the bottom of the devices. Remove the rubber inserts from the feet first, behind which the screws are concealed.
- ⑤ If the two **KONSTANTERs** are to be electrically connected to one another, use the accessory "mains jumper cable".
- ⑥ Install the **KONSTANTERs** into the rack. Keep all remaining parts in a safe place for possible future use.
- ⑦ The **KONSTANTERs** must be supported in the rack at both sides with slide rails. The slide rails, as well as the screws required for securing the **KONSTANTER's** front panels are rack-specific, and must thus be procured from your rack supplier.

## 2.5 Multiple Benchtop Device Combination

Up to 3 **KONSTANTERs** can be stacked to create a multiple benchtop device combination (see also chapter 5 regarding possible electrical connections via the analog interface).

- ① Unscrew the feet from the bottom of the device. Remove the rubber inserts from the feet first, behind which the screws are concealed. Four large slotted holes are now visible at the bottom of the device.
- ② Turn the four collar screws from the device feet into the threads at the top of the other device housing. Keep the 4 lock washers and device feet in a safe place.
- ③ Set the **KONSTANTER** without feet on top of the other **KONSTANTER**. The screws from the bottom device must protrude through the enlarged openings in the bottom of the top device. Push the top device back slightly, until the screws snap into place.
- ④ Screw the housings together at the threaded through-holes in the cable spacers at the back of the devices. This secures the top device against slipping.
- ⑤ If the two **KONSTANTERs** are to be electrically connected to one another, use the accessory "mains jumper cable".

### 3 Controls, Displays and Connectors

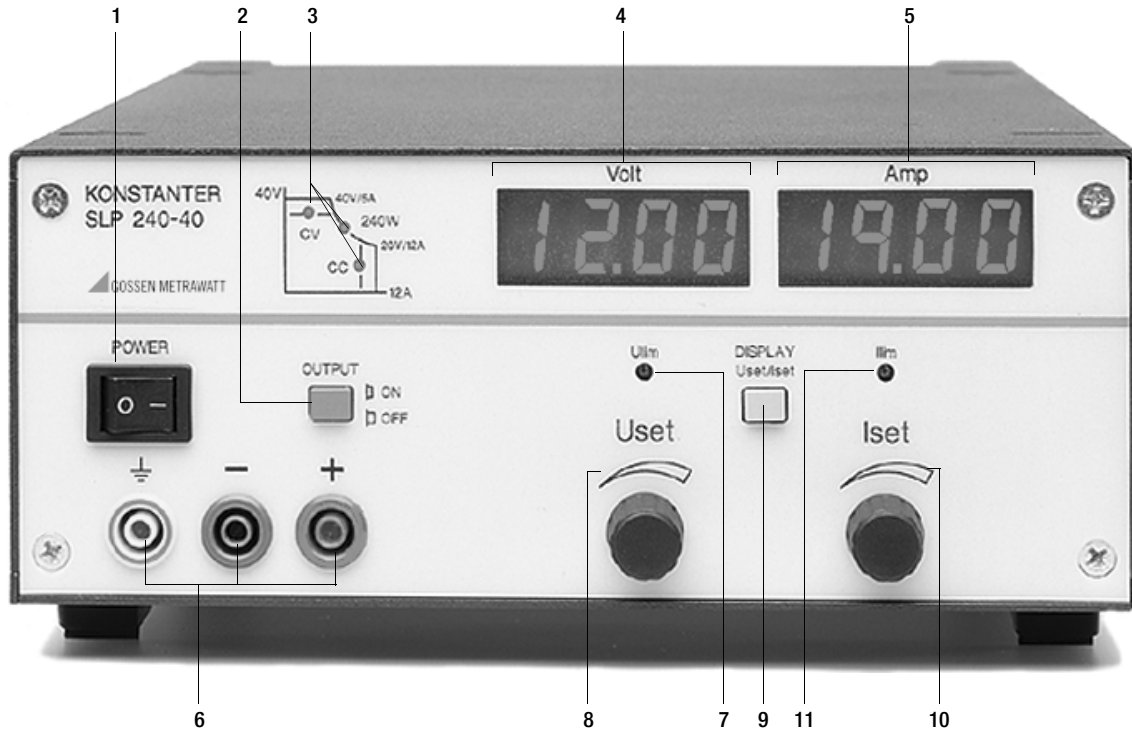

Figure 3.1 Front Panel Controls, Displays and Connectors

#### [1] Mains Switch <POWER>

For switching the **KONSTANTER** on and off. After mains power has been switched on, the **KONSTANTER** adjusts itself to all of the values which have been predetermined by manual control settings or signals received at the analog interface. It is then switched to the standby mode and is ready for operation. When the **KONSTANTER** is switched off, it is disconnected at both poles from the mains and the output is deactivated.

#### CAUTION!

Do not switch the device on and off repeatedly at short intervals. Effectiveness of in-rush current limiting may be impaired in such cases, which may cause the mains fuse to blow!

#### [2] Output ON/OFF key <OUTPUT>

The power output is activated and deactivated by pressing the <OUTPUT> key. If the output is active, one of the control mode displays lights up, namely **CV** or **CC** [3].

No significant output voltage overshooting occurs during activation and deactivation of the power output. When the device is switched off, an electronic sink is activated for approximately 300 ms, which rapidly discharges the output capacitors. The output then becomes "highly resistive" ( $R_i > 50 \text{ k}\Omega \parallel 250 \mu\text{F}$ ).

☞ Refer to chapter 4.3 for detailed information.

#### CAUTION!

The output terminals are not electrically isolated when the output is deactivated.

#### [3] Control Mode Displays

The three LEDs indicate the current operating status (control mode) of the output.

"CV" illuminated Constant voltage mode ( $U_{out} = U_{set}$ )  
 "CC" illuminated Constant current mode ( $I_{out} = I_{set}$ )  
 "Pmax" illuminated Overload limiting / overtemperature protection has been triggered. The output is deactivated as a result.

#### [4] Left-Hand Display

The measured value for output voltage  $U_{out}$  in volts appears as the standard display value at the left-hand display. As long as the <DISPLAY Uset/Iset> key [9] is depressed, the manually selected voltage setpoint  $U_{set}$  appears at the display.

Type / Nom. Voltage	Display Resolution / Range
20 V	0.01 (max. 19.99)
32/40/80 V	0.1 (xx.x)

#### [5] Right-Hand Display

The measured value for output current  $I_{out}$  in amperes appears as the standard display value at the right-hand display. As long as the <DISPLAY Uset/Iset> [9] key is depressed, the manually selected current setpoint  $I_{set}$  appears at the display.

Display Resolution / Range
0.01 (max. 19.99)

☞ Refer to chapter 4.3 for detailed information.

#### [6] Front Panel Output

The selected constant voltage or constant current is made available at the safety jacks at the front panel, or at the terminals on the rear panel [13].

- (blue)	Negative output terminal
+ (red)	Positive output terminal
⊥ (yellow-green)	The output can be grounded here if desired, or the shield can be connected here if shielded power leads are used. The ground terminal is connected to the housing and the mains connection earthing contact.

☞ Refer to chapter 2.2 for detailed information.

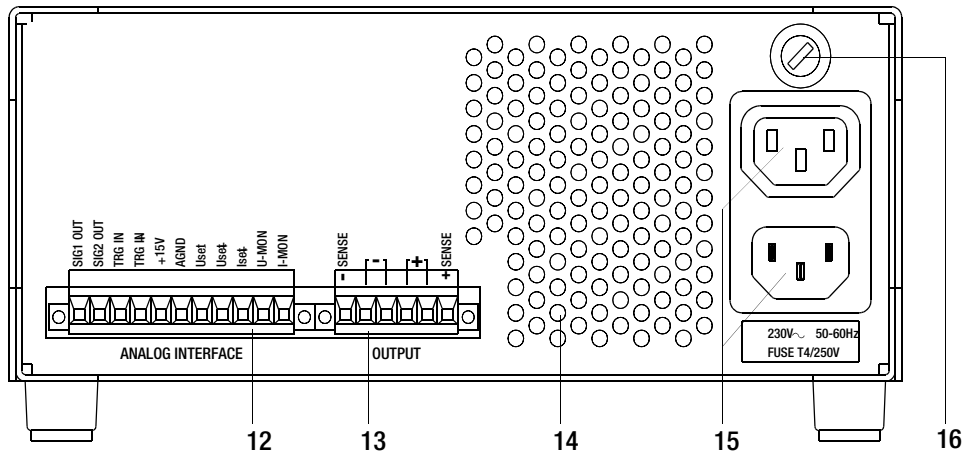

Figure 3.2 Controls and Connectors at the Rear Panel

**[7] Limit Value Adjustment <Ulim>**

The upper limit value Ulim for the voltage setting range is selected with this trimming potentiometer. Use a size 3 screwdriver only for this adjustment.

☞ Refer to chapter 4.1.2 for detailed information.

**[8] Rotary Knob for Voltage Setpoint Adjustment <Uset>**

Output voltage can be set with this rotary knob. Adjustment is accomplished with a ten-turn potentiometer and allows for precise adjustment of the voltage setpoint Uset, selected within the range defined by means of Ulim [7].

Press the key [9] in order to display the setpoint value Uset.

☞ Refer to chapter 4.1.3 for detailed information.

**[9] Display Switching Key <Uset/Iset>**

The two displays [4/5] can be switched from Uout/Iout to Uset/Iset by pressing the key [9].

The key must be pressed and held in order to continuously monitor changes to Uset/Iset or Ulim/Ilim during adjustment.

**[10] Rotary Knob for Current Setpoint Adjustment <Iset>**

This rotary knob functions just like the rotary knob for voltage setpoint adjustment [8].

The display can be switched to the **present current setpoint value Iset** by pressing the key [9] <DISPLAY Uset/Iset>.

☞ Refer to chapter 4.2.3 for detailed information.

**[11] Limit Value Adjustment <Ilim>**

The upper limit value Ilim for the current setting range is selected with this trimming potentiometer. Use a size 3 screwdriver only for this adjustment.

☞ Refer to chapter 4.2.3 for detailed information.

**[12] Analog Interface**

**CAUTION!**

**The contacts at the analog interface are connected to electronic components which may be damaged by electrostatic discharge. Before touching any contacts, neutralize the potential difference between yourself and the KONSTANTER by touching the housing!**

The analog interface provides for the following functions:

- Remote setting of output voltage and current with analog control voltages ranging from 0 to 5 V or –5 to 0 V

☞ Refer to chapters 5.4 and 5.5 for detailed information.

- External measurement or recording of output voltage and current by means of monitor signals ranging from 0 to 10 V

☞ Refer to chapters 5.6 and 5.7 for detailed information.

- +15 V auxiliary power supply to the trigger input or external control devices
- Linking of several **KONSTANTERs** for master-slave operation

☞ See chapters 5.8.2 and 5.9.2 for detailed information.

- For varying internal output resistance

☞ Refer to chapter 5.10 for detailed information.

- For activating and deactivating the output via the floating TRIGGER input

☞ Refer to chapter 5.3 for detailed information.

**[13] Rear Panel Output**

The OUTPUT interface can be used for two different functions:

- Pick off constant voltage or constant current from the rear panel of the **KONSTANTER** via the terminal strip
- Connect the sensing leads for the compensation of voltage drops at the power leads

☞ Refer to chapters 2.2 and 2.3 for detailed information.

**[14] Air Outlet**

The air outlet vents regulate temperature inside the **KONSTANTER**. Warm air generated during operation is exhausted via the air outlet vents with the help of a temperature controlled fan.

**CAUTION!**

**The air outlet may not be closed off and, it must be possible for warm air to be exhausted freely via the air outlet vents. Non-observance may trigger overtemperature protection and deactivate the output (see chapter 4.3).**

**[15] Mains Power Input**

Mains power input with looped through mains outlet for connection to inlet connectors for non-heating apparatus. The looped through mains outlet allows for direct connection of up to 3 **KONSTANTERs** with two short power cables with inlet connectors for non-heating apparatus. Only one power cable is thus required for operation of three devices.

☞ Refer to chapter 2.1 for detailed information.

**[16] Mains Fuse**

Fusing at the mains power input:

All device types: T 4.0 A / 250 V (6.3 x 32 mm)

The second mains input pole is fused internally with:

T 5.0 A / 250 V (5 x 20 mm)

**WARNING!**

**When replacing blown fuses, use only fuses of the specified type with the specified current rating.**

**Any tampering with fuses or the fuse holder (“mending” fuses or short-circuiting the fuse holder etc.) is strictly prohibited.**

## 4 Adjusting Output Values

### 4.1 Output Voltage

#### 4.1.1 Uout – Presently Measured Voltage Value

- The left-hand digital display [4] <Volt> indicates the measured value **Uout** for voltage present at the output terminals.
  - During sensing mode operation, the displayed value corresponds to voltage acquired from the sensing leads at the consuming device.
  - The 3½ place measured value display is refreshed approximately 3 times per second. Overflow is indicated for measured values of greater than 19.99 at 20 V devices.
  - If output voltage is superimposed with an alternating voltage, the arithmetic mean value is displayed.
- ☞ Refer to chapter 1.4.3, Electrical Data, regarding measuring range, measuring resolution and measuring accuracy.

#### 4.1.2 Ulim – Limit Value for Uset

##### Function

- Defines the voltage adjustment setting range <Uset> [8]
- Prevents **inadvertent**, excessively high voltage setpoint values (Uset) during manual operation.
- If **Ulim** is set to **0 V** (full left), the voltage adjusting potentiometer <Uset> is **disabled** (e.g. for adjustment of output voltage by means of the analog interface).

##### Setting Ulim

- **Ulim** is adjusted with the **left-hand trimming potentiometer** [7] <Ulim>.
- Use a **size 3 screwdriver** only in order to avoid damaging the potentiometer.
- Deactivate the output: <OUTPUT> "OFF".
- First set **Uset** to its **maximum value** (turn potentiometer [8] <Uset> clockwise as far as it will go).
- Press the **key** [9] <DISPLAY Uset/Iset>.
- The left-hand display [4] <Volt> is switched from the **presently measured voltage value Uout** to the manually **selected voltage setpoint Uset**.
- Hold this **key depressed**.
- **At the same time, turn** <Ulim> [7] with the screwdriver until <Volt> appears at the display [4] as the selected voltage for **Ulim**.
- **To increase voltage:** Turn **clockwise**
- **To decrease voltage:** Turn **counterclockwise**
- The selected voltage is now the **maximum voltage value** to which **Uset** can be adjusted manually.

##### Setting Range

- The <Ulim> potentiometer can be turned **270°**, which corresponds to a setting range of  $0\text{ V} \leq U_{\text{lim}} \leq U_{\text{nom}}$ .
- The **10 revolutions which are possible** with the <Uset> rotary knob [8] **always** correspond to a **range of 0 V to Ulim**.

#### 4.1.3 Uset – Voltage Setpoint Value

##### Function

- Predefined voltage at which the consuming device is to be operated

##### Adjusting Uset

- **Uset** is adjusted with the **left-hand rotary knob** [8] <Uset>.
- First press the **key** [9] <DISPLAY Uset/Iset>.
- The left-hand display [4] <Volt> is switched from the **presently measured voltage value Uout** to the manually **adjusted voltage setpoint Uset**.
- Hold this **key depressed**.
- **At the same time, turn** the rotary knob [8] <Uset>.
- **To increase voltage:** Turn **clockwise**
- **To decrease voltage:** Turn **counterclockwise**
- If the **output is activated** <OUTPUT> "ON", output voltage is adjusted directly by turning rotary knob.
- If the **output is deactivated** <OUTPUT> "OFF", no voltage is present at the output during adjustment. Voltage is not applied to the output until it is activated <OUTPUT> "ON".
- After **releasing the key** [9] <DISPLAY Uset/Iset>, the display [4] is **switched back to the measured value** for output voltage Uout.

##### CAUTION!

The **Uset** value can also be changed when the KONSTANTER is not in operation.

##### Setting Range

- The rotary knob can be turned **10 revolutions**.
- The **10 revolutions which are possible** with the <Uset> potentiometer [8] **always** correspond to a **range of 0 V to Ulim**.
- The selection of a **low value** for **Ulim** allows for "finer" adjustment of the **Uset** value.  
The setting accuracy specified in chapter 1.4.3 makes reference to the respectively displayed setpoint value.
- 19.99 is the highest value which can be displayed for Uout and Uset with **20 V devices**.  
The A-D converter generates an **overflow display** for values beyond this limit:



## 4.2 Output Current

### 4.2.1 Iout – Presently Measured Current Value

- The right-hand digital display [5] <Amp> indicates the measured value **Iout** for current at the output.
  - If output current is superimposed with an alternating current, the arithmetic mean value is displayed.
  - The 3½ place measured value display is refreshed approximately 3 times per second. Overflow is indicated for measured values of greater than 19.99 at 20 A devices.
- ☞ Refer to chapter 1.4.3, Electrical Data, regarding measuring range, measuring resolution and measuring accuracy.

### 4.2.2 Ilim – Limit Value for Iset

#### Function

- Defines the current adjustment setting range <Iset> [8].
- Prevents **inadvertent**, excessively high Iset values.
- If Ilim is set to 0 V (full left), the current adjusting potentiometer <Iset> is **disabled** (e.g. for adjustment of output current by means of the analog interface).

#### Setting Ilim

- The procedure for adjusting the Iset limit value is identical to the procedure used to adjust the Uset limit value (4.1.2).
- **The following controls and displays do however vary:**  
Left trimmer [7] <Ulim> → Right trimmer <Ilim> [11]  
Left rotary knob [8] <Uset> → Right rotary knob <Iset> [10]  
Left display [4] <Volt> → Right display <Amp> [5]

#### Setting Range

- The <Ilim> potentiometer can be turned 270°, which corresponds to a setting range of  $0\text{ A} \leq I_{lim} \leq I_{nom}$ .
- The **10 revolutions which are possible** with the <Iset> rotary knob [10] **always** correspond to a range of 0 A to Ilim.

### 4.2.3 Iset – Current Setpoint Value

#### Function

- Predefined current at which the consuming device is to be operated.

#### Adjusting Iset

- The procedure for adjusting the current setpoint is identical to the procedure used to adjust Uset (4.1.3).
- **The following controls and displays do however vary:**  
Left rotary knob [8] <Uset> → Right rotary knob <Iset> [10]  
Left display [4] <Volt> → Right display <Amp> [5]

#### CAUTION!

The Uset value can also be changed when the KONSTANTER is not in operation.

#### Setting Range

- The **10 revolutions which are possible** with the <Iset> rotary knob [10] **always** correspond to a range of 0 A to Ilim.
- The selection of a **low value** for Ilim allows for “finer” adjustment of the Iset value.  
The setting accuracy specified in chapter 1.4.3 makes reference to the respectively displayed setpoint value.
- Overflow display  
for settings of greater than 19.99 at 20 A devices: 

## 4.3 OUTPUT – Switching the Power Output On and Off

- The power output is switched on and off with the red detented key [9] <OUTPUT>.
- Pressing the <OUTPUT> key activates or deactivates the power output.  
OUTPUT OFF → OUTPUT ON  
OUTPUT ON → OUTPUT OFF
- The power output can be deactivated for adjustments to Uset, Ulim, Iset and Ilim in order to prevent damage to the consuming device due to inadvertent, excessively high settings.
- If the power output is deactivated, “**OUTPUT OFF**”, the control mode displays are switched off.
- If the power output has been deactivated by means of **overtemperature protection**, the **yellow “Pmax” LED** in the control mode display [3] lights up. The output cannot be reactivated until the **KONSTANTER** has cooled back down to its normal operating temperature.
- **Additional functions which may deactivate the power output:**
  - ✗ External control signal to TRG IN at the analog interface (see also chapters 5.1 and 5.3)
  - ✗ **Overvoltage protection** is triggered as soon as voltage at the output terminals exceeds approximately 125% of Unom.  
Cause:
    - **Excessively high** setting for **output voltage** by means of Uset control signal to the analog interface
    - **Voltage transient** while switching an inductive consumer
    - **Unipolar power recovery** from interconnected consumers (e.g. DC motors) or from parallel connected voltage sources
    - **Sensing mode operation:** sensing leads connected with **reversed polarity** or a **power lead** is/was **interrupted**

The “**CV**” display for constant voltage operation **remains illuminated**. However, the display for output voltage or output current drops to zero. **At the same time, SIG1OUT** indicates “**OUTPUT OFF**”.

After eliminating the cause of triggering, the output can be reactivated.

- ✗ **Overtemperature protection** is triggered

Cause:

- **Impaired cooling**, e.g. closed off air inlet or air outlet vents
- Excessively high **ambient temperature** or **load**:  
The device is able to deliver nominal power during continuous operation at a maximum ambient temperature of 40 °C (measured at air inlet vents)
- Defective fan

After the device has cooled sufficiently, the output is reactivated automatically.

#### CAUTION!

The output terminals are not electrically isolated when the output is deactivated.



## 5 Control via the Analog Interface

### 5.1 Connector Assignments

#### SIG1 OUT, SIG2 OUT (output)

- Digital status signal outputs with reference to AGND
- SIG1 OUT** indicates the status of the power output
- SIG2 OUT** indicates the current control mode
- Signal type: open collector
- Max. switching voltage: 30 V DC
- Max. switching current: 20 mA

☞ Refer to chapter 5.2 for detailed information.

#### TRG IN+, TRG IN- (input)

- Floating digital control input for switching the power output on and off
- Low signal:  $-26 \text{ V} \leq U_s \leq +1 \text{ V}$
- High signal:  $+4 \text{ V} \leq U_s \leq +26 \text{ V}$   
 $I_s = (U_s - 2 \text{ V}) / 1.5 \text{ k}\Omega$

☞ Refer to chapter 5.3 for detailed information.

#### +15 V (output)

- This auxiliary voltage output (14 ... 17.5 V DC with reference to AGND) can be used to control the trigger input or to supply external consumers with power (e.g. reference component for the generation of control voltages).
- The output is equipped with electronic current limiting to approximately 60 mA, and is short-circuit proof to AGND.

#### AGND (analog ground = reference point)

- Reference point for analog control inputs and outputs
- This terminal is internally connected to the negative pole of the power output via an automatic resetting fuse (110 mA rating).

#### Uset-, Uset+ (input)

- Analog (differential) **voltage input** with reference to AGND for controlling output voltage. The following applies when the output is active:

- $U_{out} = U_{SET} + U_{SU} \cdot k_{SU}$
- $U_{out}$ : **output voltage** during constant voltage operation
- $U_{SET}$ : **manually selected voltage setpoint value**
- $U_{SU}$ : **external control voltage** (0 ... 5 V  $\triangleq$  0 ...  $U_{out_{nom}}$ )
- $k_{SU}$ : **voltage control coefficient** =  $U_{out_{nom}} / 5 \text{ V}$
- $R_{SU}$ : **input impedance** Uset+: 10 k $\Omega$   
Uset-: 15 k $\Omega$

☞ Refer to chapter 5.4 for detailed information.

#### Iset+ (input)

- Analog **voltage input** with reference to AGND for controlling output current. The following applies when the output is active:

- $I_{out} = I_{SET} + U_{SI} \cdot k_{SI}$
- $I_{out}$ : **output current** during constant current operation
- $I_{SET}$ : **manually selected current setpoint value**
- $U_{SI}$ : **external control voltage** (0 ... 5 V  $\triangleq$  0 ...  $I_{out_{nom}}$ )
- $k_{SI}$ : **current control coefficient** =  $I_{out_{nom}} / 5 \text{ V}$
- $R_{SI}$ : **input impedance**: 10 k $\Omega$

☞ Refer to chapter 5.5 for detailed information.

#### U-MON (output)

- Analog voltage output, proportional to output voltage  $U_{out}$  which is acquired by the sensing leads (0 ... 10 V  $\triangleq$  0 ...  $U_{out_{nom}}$ ).
- This output, with reference to AGND, has an internal resistance of 9.8 k $\Omega$  and is **short-circuit proof**.

☞ Refer to chapter 5.6 for detailed information.

#### I-MON (output)

- Analog voltage output proportional to actual output current  $I_{out}$  (0 ... 10 V  $\triangleq$  0 ...  $I_{out_{nom}}$ )
- This output, with reference to AGND, has an internal resistance of 9.4 k $\Omega$  and is **short-circuit proof**.

☞ Refer to chapter 5.7 for detailed information.

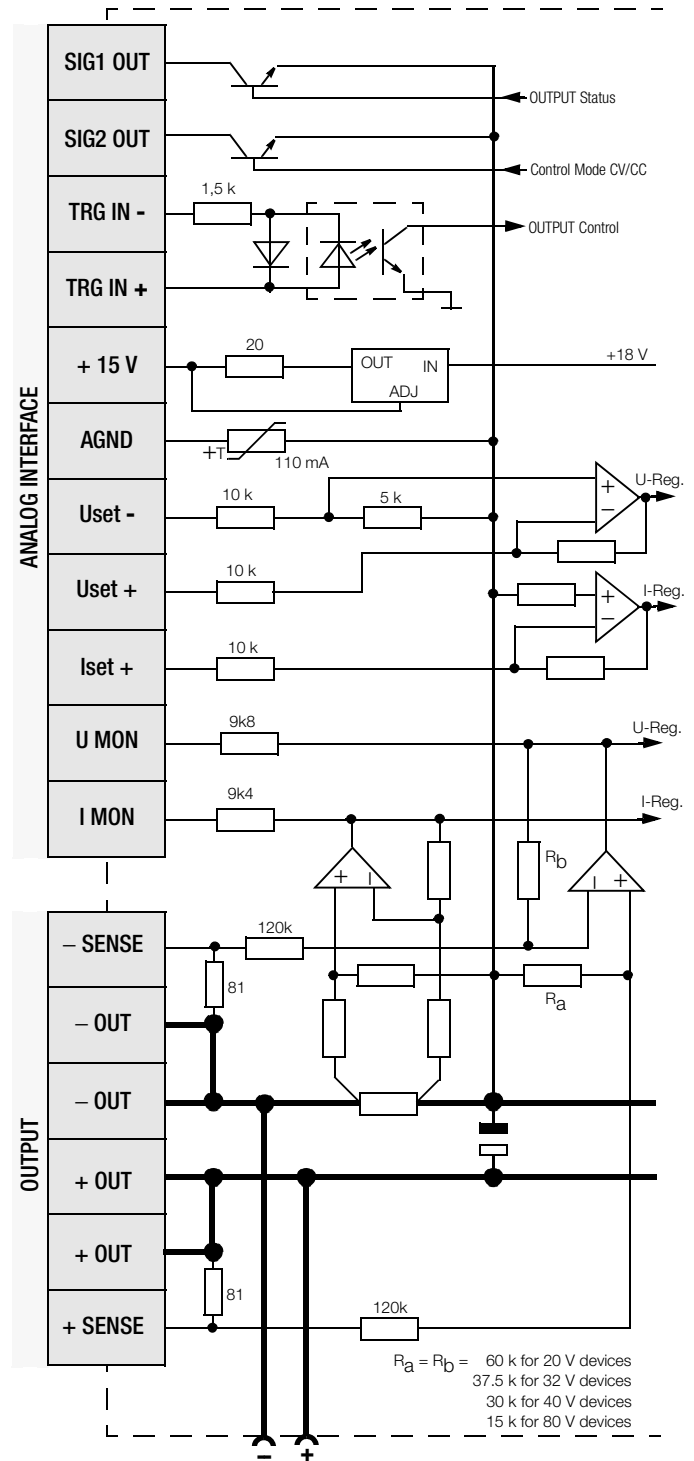

Figure 5.1 Internal connection to the analog interface and the output (simplified schematic)

## 5.2 Status Signal Outputs

### Function

- The **KONSTANTER** includes two digital open collector outputs with reference to AGND for the generation of status signals.
- SIG1 OUT** – indicates **activation status** of the **power output OUTPUT ON** = passive high (= OFF)  
**OUTPUT OFF** = active low (= ON)
  - If this output is connected to the trigger input of a second **KONSTANTER**, the power outputs of both devices can be activated and deactivated simultaneously (see also chapters 5.8.2 and 5.9.2).
  - As a **message signal** for transmission to monitoring equipment
  - For the **control** of external **output relays**  
Due to the fact that output voltage drops off very quickly when the output is switched off (< 1 ms), the relay can be released load-free with resistive consumers.
- SIG2 OUT** – indicates the active **power output control mode**.
  - Constant current (**CC**) or overload (**Pmax**) = active low (= ON)
  - Constant voltage (**CV**) or **OUTPUT OFF** = passive high (= OFF)
  - As a **message signal** to monitoring equipment

### Connection

- Connected load values  
Max. switching voltage 30 V DC  
Max. switching current 20 mA  
Low level < 1 V at  $I_s \leq 20$  mA
- In order to generate an “active high” signal of + 15 V, the status signal outputs can be connected to the +15 V terminal with pull-up resistors  $R_{PU}$  with a value of at least 1 k $\Omega$ .

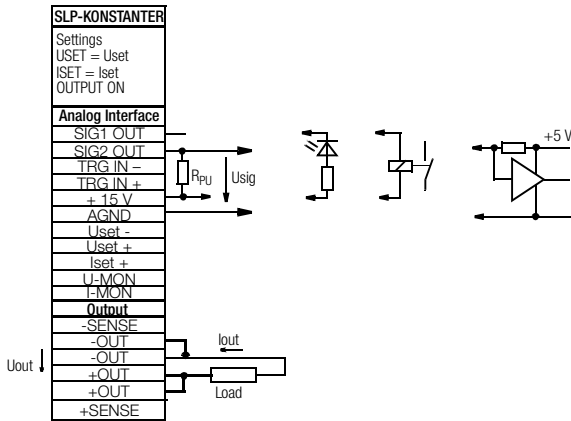

Figure 5.2 Wiring examples for the status signal outputs

## 5.3 Trigger Input

### Function

- The **floating optocoupler input “TRG IN”** allows for **remote control** of a the **OUTPUT** function with a binary control signal.
- The trigger input is only active as long as the **OUTPUT** key is depressed (**ON**).
- If this input is connected to the signal of a second **KONSTANTER**, the power outputs of both devices can be activated and deactivated simultaneously (see also chapters 5.8.2 and 5.9.2).
- The **OUTPUT ON/OFF** function can be controlled by means of user-specific signals to the trigger input in **automated testing systems**.

### Connection

- Connect the control signal between **TRG IN +** and **TRG IN -**. Appropriate signal levels are listed in the following table.

Signal	$U_s$	$I_s$	Output
High	4 ... 26 V DC	$(U_s - 2 \text{ V}) / 1.5 \text{ k}\Omega$	OFF
Low	0 ... 1 V DC	0 mA	ON

- The **TRIGGER** can be controlled with the **+ 15 V output** at the analog interface via any desired switch (see figure 5.3 a).

### WARNING

Trigger input TRG IN is a floating input and is functionally isolated from the output current circuit.

This functional isolation is not to be construed with “protective separation” as set forth in electrical safety regulations.

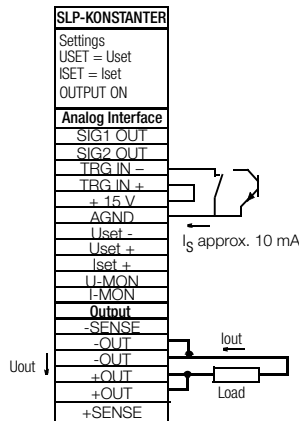

Figure 5.3 a Controlling the trigger input with a switching element

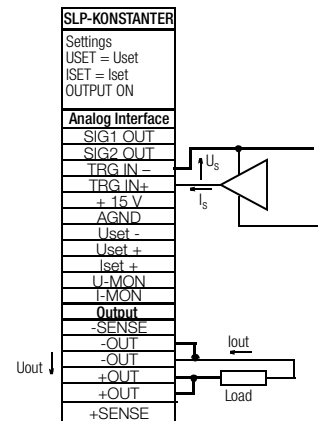

Figure 5.3 b Controlling the trigger input with an external signal

## 5.4 Controlling Output Voltage

### Function

- Output voltage **U<sub>out</sub>** can be controlled via control inputs **Uset+** (non-inverting) and **Uset-** (inverting) with an external control voltage **U<sub>su</sub>**.
- The following applies during constant voltage operation:  

$$U_{out} = USET + U_{su} \cdot k_{su}$$
 USET: manually selected voltage setpoint value  
 k<sub>su</sub>: voltage control coefficient =  $U_{out_{nom}} / 5 \text{ V}$   
 – **Max. setting error:**  $\pm 0.05\%$  of  $U_{nom} \pm 2\%$  of setting value
- The voltage control input has been designed as a differential voltage input:  
 Uset+: non-inverting input:  
 $U_{su} = 0 \dots +5 \text{ V}$  for  $U_{out} = 0 \text{ V} \dots U_{out_{nom}}$ ,  
 input impedance: 10 kΩ  
 Uset-: inverting input:  
 $U_{su} = 0 \dots -5 \text{ V}$  for  $U_{out} = 0 \text{ V} \dots U_{out_{nom}}$ ,  
 input impedance: 15 kΩ

### Notes

- The **control inputs** are **not floating inputs**, the reference point **AGND** is connected to the **negative pole** of the power output.
- Connecting **grounded current circuits** to the control input may lead to **erroneous settings** due to leakage current or earth loops.
- If control voltage **U<sub>su</sub>** is applied to the **output's negative pole** with its **reference point at the load side**, the inverting input must be connected to this point (**connection b** in figure 5.4 a). Influences caused by voltage drops at the load conductor are thus avoided.
- If **control voltage** is electrically **isolated from the output**, connect **Uset-** to **AGND** (**connection a** in figure 5.4 a).
- If **remote control of output voltage** is to be accomplished by means of a **potentiometer**, wiring can be implemented in accordance with figure 5.4 b.
- U<sub>su</sub>** can be applied as an **alternating voltage**, e.g. in order to superimpose the selected direct voltage **USET** with **fault signals**. The **cut-off frequency** of the modulated output voltage **depends** upon **voltage amplitude**. However, the cut-off frequency remains largely independent of load and the selected current limit thanks to special circuit technology.

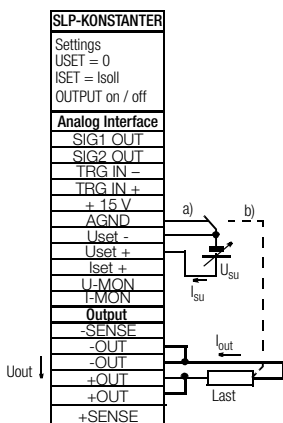

Figure 5.4 a Wiring for control of output voltage with an external voltage

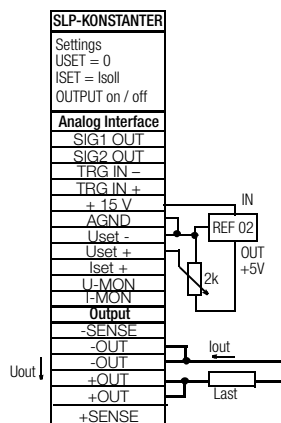

Figure 5.4 b Wiring for control of output voltage with an external potentiometer

## 5.5 Controlling Output Current

### Function

- Output current **I<sub>out</sub>** can be controlled with an external control voltage **U<sub>si</sub>** via the control input **Iset+**.
- The following applies during constant current operation:  

$$I_{out} = ISET + U_{si} \cdot k_{si}$$
 ISET: manually selected current setpoint value  
 k<sub>si</sub>: current control coefficient =  $I_{out_{nom}} / 5 \text{ V}$   
**Max. setting error:**  $\pm 0.1\%$  v.  $I_{nom} \pm 2\%$  of setting value
- Current Control Input  
 Iset+: non-inverting input:  
 $U_{si} = 0 \dots +5 \text{ V}$  for  $I_{out} = 0 \text{ A} \dots I_{out_{nom}}$ ,
- Input impedance is equal to 10 kΩ.

### Notes

- The **control input** is **not a floating input**, the reference point **AGND** is connected to the **negative pole** of the power output.
- Connecting **grounded current circuits** to the control input may lead to **erroneous settings** due to leakage current or earth loops.
- Control voltage **U<sub>si</sub>** may **not** be connected to the **input's negative pole at the load side** (see figure 5.5 a).
- If **remote control of output current** is to be accomplished by means of a **potentiometer**, wiring can be implemented in accordance with figure 5.5 b.
- U<sub>si</sub>** can be applied as an **alternating voltage**, e.g. in order to superimpose the selected direct current **ISET** with **fault signals**. The **cut-off frequency** of the modulated output current **depends** upon the load-related **voltage amplitude**.

### CAUTION!

Control inputs **Uset +**, **Uset -** and **Iset +** should only be connected with **shielded cable**.

Connect the shield to reference point **AGND**.

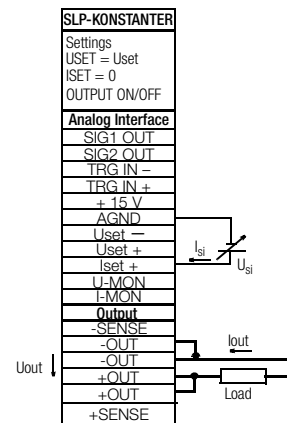
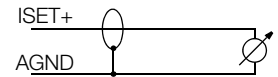
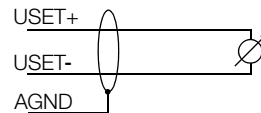

Figure 5.5 a Wiring for control of output current with an external voltage

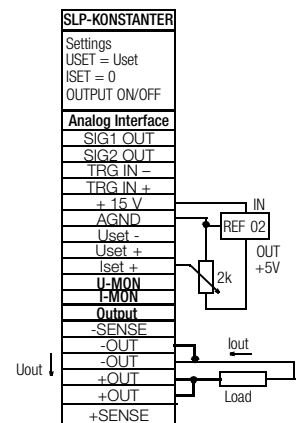

Figure 5.5 b Wiring for control of output current with an external potentiometer

## 5.6 Voltage Monitoring Output

### Function

- The **U-MON** terminal, with reference to **AGND**, supplies a voltage  $U_{MU}$  which is **proportional to Uout**.
- U-MON** is used as a control voltage for **series master-slave** connection (see 5.9.2).
- U-MON** can also be used for external **measuring, monitoring and recording purposes**.
- The following applies:
 
$$U_{MU} = U_{out} \cdot k_{MU} \cdot k_{load} = 0 \dots 10 \text{ V}$$

$$k_{MU} = 10 \text{ V} / U_{out_{nom}}, \text{ U monitor coefficient}$$

$$R_i(\text{U-MONITOR}) = 9.8 \text{ k}\Omega, \text{ U monitor internal resistance}$$

Load Coefficient

$$k_{load} = \frac{R_{load}}{R_{load} + 9.8 \text{ k}\Omega}$$

$R_{load}$  = load resistance

**Max. error,  $U_{MU}$ :**  $\pm 5 \text{ mV} \pm 2\%$  actual value (where  $R_{load} > 10 \text{ M}\Omega$ )

### Notes

- U-MON** is **not potential-free**, its reference point **AGND** is connected to the negative pole of the output.
- Connecting **grounded measuring circuits** to the monitoring output may lead to **erroneous measurements** due to leakage current or earth loops.
- The voltage monitoring output makes reference to output voltage acquired by the sensing leads (see chapter 2.3).
- The monitoring output is **short-circuit proof**.
  - Internal resistance** is equal to  $9.8 \text{ k}\Omega$ .

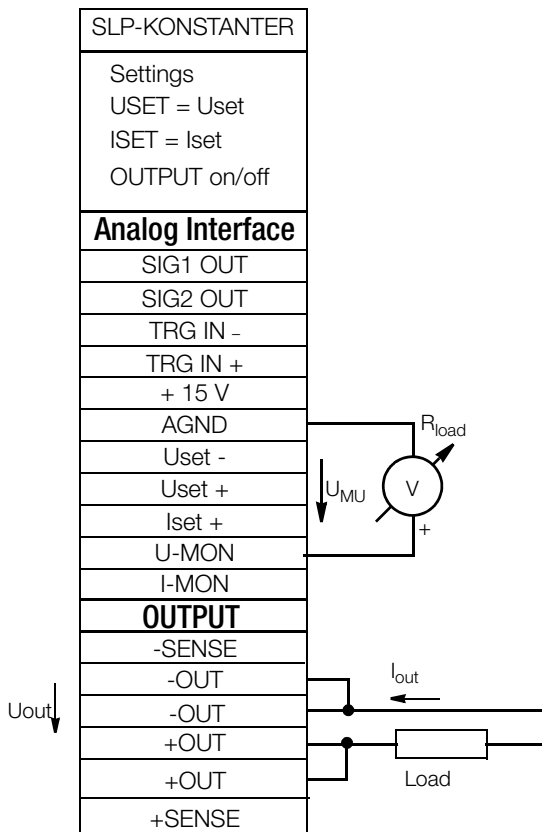

Figure 5.6 Voltage Monitor Wiring

## 5.7 Current Monitoring Output

### Function

- The **I-MON** terminal with reference to **AGND** supplies a current  $U_{MI}$  which is **proportional to Iout**.
- I-MON** is used as a control voltage for **parallel master-slave** connection (see 5.8.2 and 5.8.3).
- I-MON** can also be used for external **measuring, monitoring and recording purposes**.
- The following applies:
 
$$U_{MI} = I_{out} \cdot k_{MI} \cdot k_{load} = 0 \dots 10 \text{ V}$$

$$k_{MI} = 10 \text{ V} / I_{out_{nom}}, \text{ I monitor coefficient}$$

$$R_i(\text{I-MONITOR}) = 9.4 \text{ k}\Omega, \text{ I monitor internal resistance}$$

Load Coefficient

$$k_{load} = \frac{R_{load}}{R_{load} + 9.4 \text{ k}\Omega}$$

$R_{load}$  = load resistance

**Max. error,  $U_{MI}$ :**  $\pm 5 \text{ mV} \pm 2\%$  actual value (where  $R_{load} > 10 \text{ M}\Omega$ )

### Notes

- I-MON** is **not a potential-free**, its reference point **AGND** is connected to the negative pole of the output.
- Connecting **measuring current circuits** to the monitoring output may lead to **erroneous measurements** due to leakage current or earth loops.
- The monitoring output is **short-circuit proof**.
  - Internal resistance** is equal to  $9.4 \text{ k}\Omega$

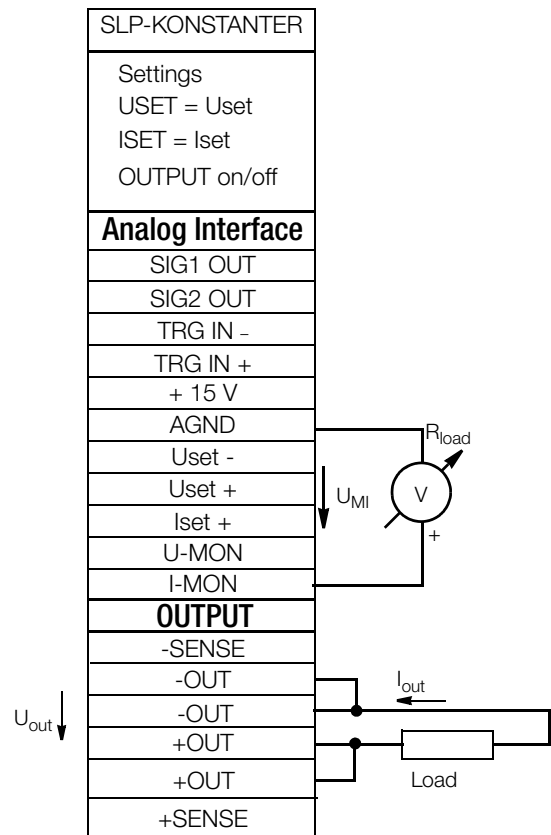

Figure 5.7 Current Monitor Wiring

## 5.8 Parallel Operation

The outputs of any number of KONSTANTERs can be parallel connected if output current from a single KONSTANTER is insufficient for your application.

### CAUTION

If outputs with different nominal voltage values are parallel connected, all of the outputs must be limited to the lowest nominal voltage value within the system.

This setting is accomplished with the Ulim parameter.

### 5.8.1 Direct Parallel Operation

#### Function

- Simplest way to increase current to the consumer to a level greater than that provided by a single KONSTANTER.
- KONSTANTERs with different nominal output voltages can be used. However, all voltage setpoints must be limited to the same value.
- Less suitable for constant voltage operation

#### Wiring

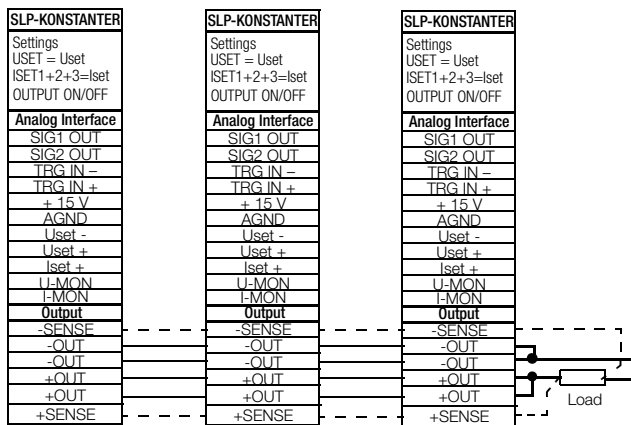

- - - - = Only required for sensing mode operation

Figure 5.8.1 a Wiring for Direct Parallel Operation

#### Procedure

- Deactivate all outputs.
- Adjust voltage setpoint values USET for all parallel connected KONSTANTERs to approximately the same value:  
 $U_{set} = U_{SET1} = U_{SET2} = U_{SET3} = U_{SETn}$
- Adjust current setpoint values ISET such that the desired cumulative current setpoint value Iset is achieved:  
 $I_{set} = I_{SET1} + I_{SET2} + I_{SET3} + \dots + I_{SETn}$
- Activate the outputs.

#### Functional Principle

- Immediately after power-up, the KONSTANTER with the highest voltage setting provides the consumer with load current.
- If load resistance is continuously reduced, load current is consistently increased.
- When load current at the initially loaded output reaches the selected setpoint value ISET, current regulating is activated for this output.
- If load resistance is further reduced, current regulating reduces output voltage until the voltage value for the output with the next lowest setting has been reached.

- As of this point in time, the corresponding KONSTANTER supplies a portion of the load current.
- This process continues until the output with the lowest voltage setting is reached.
- This output maintains constant voltage at the consumer. If this output is also used for current regulation, load current is held constant as a cumulative current from all parallel connected outputs until short-circuiting occurs.

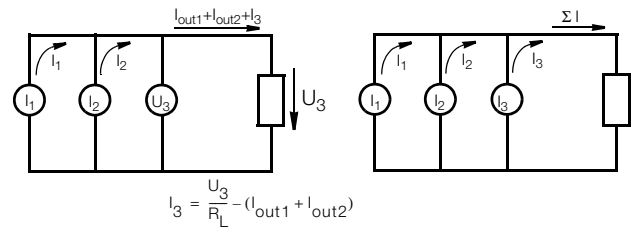

Figure 5.8.1 b Direct parallel connection with an ideal working range for voltage regulation at the consumer

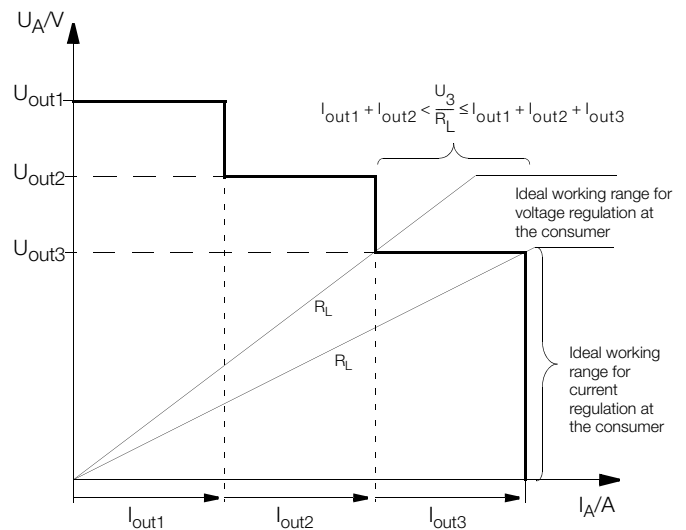

Figure 5.8.1 c U / I Diagram for Direct Parallel Connection

#### Notes

- Slightly varying voltages result at the individual outputs due to setting tolerance.  
 If large voltage differences prevail, an electronic sink becomes active at the outputs with the lower voltage settings. The sink attempts to achieve the lower voltage value - possibly in pulsating mode.  
 Neither the KONSTANTER nor the consumer are damaged during this process.  
 If load current measurement problems should occur as a result, the devices should be parallel connected for master-slave operation (see also chapter 5.8.2).
- The outputs can be activated and deactivated simultaneously by connecting the SIG1 outputs to the TRG inputs (see also chapter 5.8.2).

## 5.8.2 Parallel Master-Slave Operation

### Function

Parallel master-slave connection provides for significant **advantages** as opposed to direct parallel connection:

- Equally suitable for **voltage** and **current regulation**
- **Output parameters** (output voltage, cumulative current limiting, output ON/OFF) are **fully** controlled by the **master**.
- All interconnected **KONSTANTERS** are **equally loaded**.

### Wiring

- Define one **KONSTANTER** as the **master**.
- Connect **master** and **slave** devices as shown in figure 5.8.2.
- Connect the **power leads** (observe instructions in chapter 2.2).
- **Balance** the individual **current outputs**. Keep the connector cables as **short** as possible, and use the **largest possible** conductor cross section. Perform balancing with  $R_{match}$ .

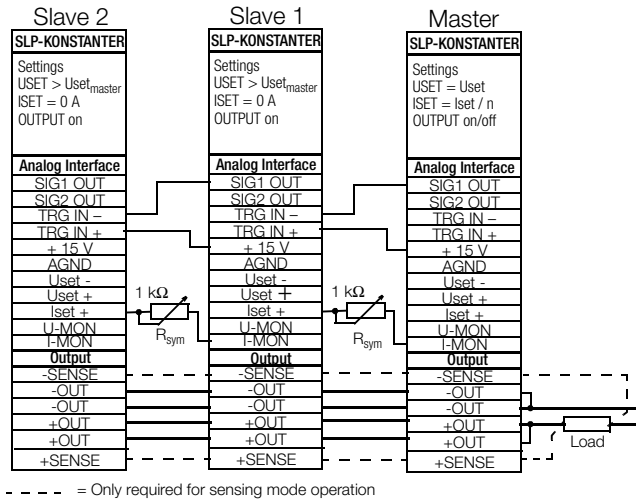

Figure 5.8.2 Wiring for Parallel Master-Slave Operation

### Procedure

#### Initial Start-Up:

- Short circuit the load.
- Switch the **master** on (mains switch) and **set:**  
**OUTPUT off**  
 $USET = Uset$ , desired output voltage  
 $ISET = Iset / n$ , Iset: desired cumulative output current, n: number of **KONSTANTERS**  
 Only valid if **nominal values** for all devices are **identical**, see notes as well.
- Switch on **slave 1** (mains switch) and **set:**  
**OUTPUT on** The output remains inactive at first even though the OUTPUT key is depressed, because it has been disabled by the master via the TRG input.  
 $USET > USET_{master}$  The voltage setpoint value must be set at least 2% higher at the slaves than at the master, e.g. to maximum.  
 $ISET = 0 A$  ISET rotary knob can be deactivated by setting Ilim to 0 A.
- Proceed as described above for all slaves.
- Press the **OUTPUT ON** key at the master. **All slave** outputs are switched on and set **simultaneously** in this way.
- Check the output levels displayed at the **KONSTANTERS**.

- **Output current for each individual slave** can be precisely **set** to match output current at the master by adjusting  $R_{match}$ . Changes appear immediately at the respective display.
- Eliminate short-circuiting of the load.
- From now on, (cumulative) output parameters are **set** and **regulated entirely** by the **master**.

#### Repeat Start-Ups (after initial start-up):

- The **order** in which devices are switched off and back on again is **irrelevant**.

### Functional Principle

- The master controls output current at the downstream device (slave 1) via its **current control input** with the **current monitor signal**.
- **Slave 1** functions as a **master** for **slave 2** and so forth. Cumulative output current is thus always proportional to output current from the master. The master controls the **OUTPUT ON/OFF status** of the slaves via connection of the **master SIG1** output to the **slave TRG** input.

### Notes

#### Devices with Different Nominal Values

- The device with the **lowest nominal voltage** must be used as the **master**.
- The **voltage setting range** for all other devices must be **limited** to the lowest nominal value with the **ULIM** parameter.
- $I_{out,slave}$  is only equivalent to  $I_{out,Master}$  as a percentage with reference to  $I_{nom}$ .

#### Example:

<b>Master:</b>	SLP 120-20	$U_{nom}$ : 20 V	$I_{nom}$ : 10 A
	Settings:	<b>USET</b> : 12 V	<b>ISET</b> : 3 A (30%)
<b>Slave 1:</b>	SLP 120-20	$U_{nom}$ : 20 V	$I_{nom}$ : 10 A
	Results in:	<b>Uout</b> : 12 V	<b>Iout</b> : 3 A (30%)
<b>Slave 2:</b>	SLP 120-40	$U_{nom}$ : 40 V	$I_{nom}$ : 6 A
	Results in:	<b>Uout</b> : 12 V	<b>Iout</b> : 1.8 A (30%)

### General

- A **wire conductor** can be used instead of  $R_{match}$ , if an **exact setpoint value is not** required for cumulative output current. In this case, each of the **slaves** always supplies somewhat **more current** than the master.
- If the **connector leads** to the analog interface and the sensing leads are **longer than 1 m**, use **shielded** cable. Connect the **shield** to **ground / housing** or **AGND**.
- The measuring function at the master device acquires **cumulative** generated **output voltage** from all interconnected devices, but **only its own output current**. **Current values** from all of the interconnected devices must be **added together** in order to calculate **cumulative output current**.

## 5.9 Series Operation

The outputs of several devices can be connected **in series** if **output voltage** from a **single** device is insufficient, or if a  $\pm$  **voltage** needs to be generated.

### WARNING!

Maximal allowable cumulative output voltage for series connection is 120 V (or 240 V with grounded neutral).

### 5.9.1 Direct Series Operation

#### CAUTION!

When outputs with different nominal values are series connected, the highest selected current flows at all outputs in the event of short-circuit. However, internal reverse voltage protection diodes are only rated for nominal current at their own devices (see reverse voltage withstand under Technical Data). All current setpoint values must therefore be set to the lowest nominal current value of all interconnected devices. This setting is accomplished with the Ilim parameter. A diode can also be connected in the reverse direction between the output terminals at the device with lower nominal values ( $D_{e1}$ , see figure 5.9.1 a). The diode must be capable of conducting nominal current from the output with the highest nominal value.

#### Function

- Simplest way to increase voltage to the consumer to a level greater than that provided by a single device.
- Easy wiring
- Less suitable for constant current operation

#### Wiring

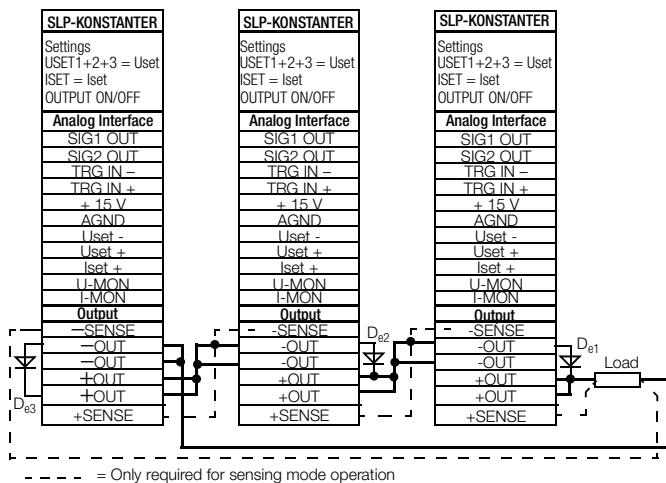

Figure 5.9.1 a Wiring for Direct Series Operation

#### Procedure

- Deactivate all outputs.
- Adjust current setpoint values ISET for all series connected devices to approximately the same value:  
 $I_{set} = ISET1 = ISET2 = ISET3 = ISETn$
- Adjust voltage setpoint values USET such that the desired cumulative voltage setpoint value Uset is achieved:  
 $U_{set} = USET1 + USET2 + USET3 + \dots + USETn$
- Activate the outputs.

#### Functional Principle

- The sum of the individual output voltages is made available to the consumer.
- If connected load resistance is continuously reduced, all outputs deliver the same load current at first.
- If load current reaches the lowest selected current setpoint value, current regulating is triggered at the respective output.
- If load resistance is further reduced, this output maintains a constant load current until its output voltage has dropped to 0 V.
- Further reduction of load resistance results in negative voltage at the respective output caused by the other outputs.
- The respective internal reverse voltage protection diode is conductive as of approximately  $-0.5$  V.
- Load current can now rise again until current regulating is triggered at the output with the next highest current setpoint value.
- This process continues until load current triggers current regulating at the output with the highest current setpoint value.
- Constant current is maintained by this final output until short-circuiting occurs.

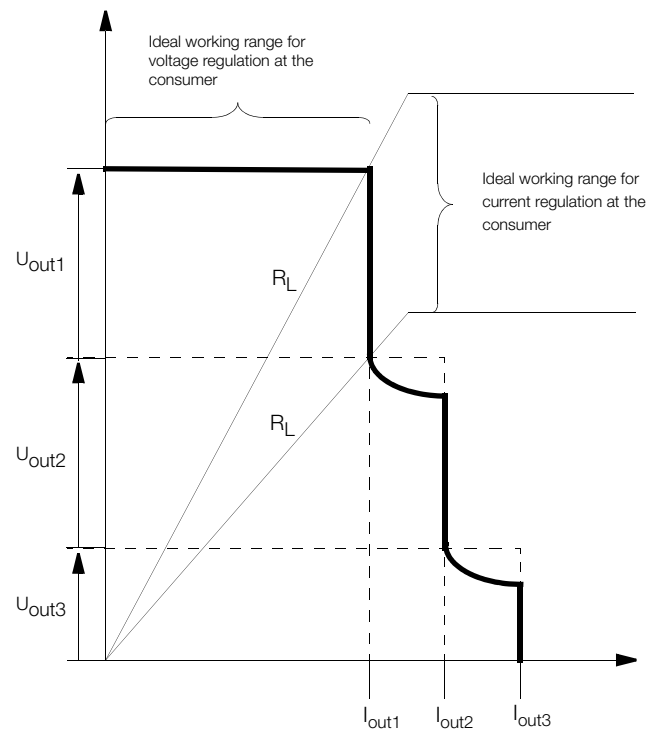

Figure 5.9.1 b U / I Diagram for Direct Series Connection

#### Note

- The outputs can be activated and deactivated simultaneously by connecting the SIG1 outputs to the TRG inputs (see also chapter 5.9.2).

## 5.9.2 Series Master-Slave Operation

### Function

Series master-slave connection provides for significant **advantages** as opposed to direct series connection:

- Equally suitable for **voltage** and **current regulation**
- **Output parameters** (cumulative output voltage, current limiting, output ON/OFF) are **fully** controlled by the **master**.
- All interconnected **KONSTANTERS** are **equally** loaded.

### Wiring

- Define one device as the **master**.
- Connect master and slave devices as shown in **figure 5.9.2**.
- Connect the **power** leads to the **external** points in the series circuit.
- **Balance** the individual **output voltages** with  $R_{match}$ .

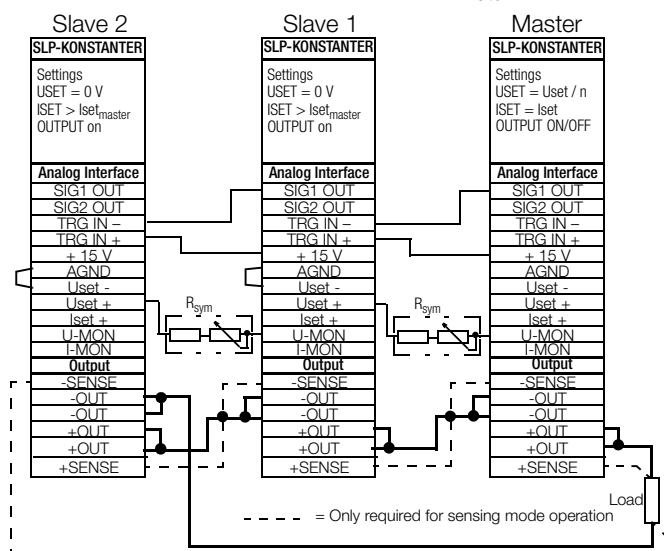

Figure 5.9.2 Wiring for Series Master-Slave Operation

- **Balancing** and **optimization** can be **simplified** by combining a fixed-value resistor (metal film resistor,  $T_k \leq 50$  ppm / K) and a trimming resistor for  $R_{match}$ .

Slave Nominal Voltage	$R_{match}$ Nominal Value	$R_{match}$ Combination
20 V	40 k $\Omega$ / 0.2 W	36 k $\Omega$ + 10 k $\Omega$ pot.
32 V	64 k $\Omega$ / 0.2 W	60 k $\Omega$ + 10 k $\Omega$ pot.
40 V	80 k $\Omega$ / 0.2 W	75 k $\Omega$ + 10 k $\Omega$ pot.
80 V	160 k $\Omega$ / 0.2 W	150 k $\Omega$ + 20 k $\Omega$ pot.

### Procedure

#### Initial Start-Up:

- Do not load the outputs (no-load operation).
- Switch the **master** on (mains switch) and **set: OUTPUT off**

**USET = Uset / n** Uset: desired cumulative output voltage  
n: number of **KONSTANTERS**

Only valid if **nominal values** for all devices are **identical**, see notes as well

**ISET = Iset** Desired current limit value

- Switch on **Slave 1** (mains switch) and **set: OUTPUT on** The output remains inactive at first even though the OUTPUT key is depressed, because it has been disabled by the master via the TRG input.
- USET = 0 V** The USET rotary knob can be deactivated by setting ULIM to 0 V.
- ISET > ISET<sub>master</sub>** Current limiting for the slaves must be set at least 2% higher than it is at the master, e.g. to max.

- Proceed as described above for all slaves.
- Press the **OUTPUT ON** key at the master. **All slave** outputs are switched on and set **simultaneously** in this way.
- Check the output voltages displayed at the **KONSTANTERS**.
- **Output voltage for each individual slave** can be precisely **set** to match output voltage at the master by adjusting  $R_{match}$ . Changes appear immediately at the respective display.
- Connect the consumer.
- From now on, (cumulative) output parameters are **set** and **regulated entirely** by the **master**.

#### Repeat Start-Ups (after initial start-up):

- The **order** in which devices are switched off and back on again is **irrelevant**.

#### Functional Principle

- The master controls output voltage at the downstream device (slave 1) via its **voltage control input** with the **voltage monitoring signal**.
- **Slave 1** functions as a **master** for **slave 2** and so forth. Cumulative output voltage is thus always proportional to output voltage from the master. The master controls the **OUTPUT ON/OFF status** of the slaves via **connection** of the **master SIG1** output to the **slave TRG** input.

#### Notes

#### KONSTANTERS with Different Nominal Values

- The **KONSTANTER** with the **lowest nominal current** must be used as the **master**.
- The **current setting range** for all other **KONSTANTERS** must be **limited** to the lowest nominal value with the **ILIM** parameter.
- $U_{out\_slave}$  is only equivalent to  $U_{out\_master}$  as a percentage with reference to  $U_{nom}$ .

Example:

<b>Master:</b>	SLP 120-40	$U_{nom}$ : 40 V	$I_{nom}$ : 6 A
	Settings:	<b>USET</b> : 12 V (30%)	<b>ISET</b> : 3 A
<b>Slave 1:</b>	SLP 120-20	$U_{nom}$ : 20 V	$I_{nom}$ : 10 A
	Results in:	<b>Uout</b> : 6 V (30%)	<b>Iout</b> : 3 A
<b>Slave 2:</b>	SLP 120-20	$U_{nom}$ : 20 V	$I_{nom}$ : 10 A
	Results in:	<b>Uout</b> : 6 V (30%)	<b>Iout</b> : 3 A

#### General

- If the **connector leads** to the analog interface and the sensing leads are **longer than 1 m**, use **shielded** cable. Connect the **shield** to **ground / housing** or **AGND**.
- The same current flows through all **KONSTANTERS**. The **measured current value** from the **master** is thus sufficient for the measurement of **load current**. **Voltage values** from all interconnected **KONSTANTERS** must be **added together** in order to calculate **cumulative output voltage**.



## 5.10 Varying Internal Output Resistance

### Function

- Internal resistance at the output is equal to practically 0 Ω in the voltage regulating mode.
- Internal resistance can be increased at the output for some applications, e.g. for the **simulation of long power leads** or **weak automotive batteries**.

The selected (open-circuit) output voltage drops proportionately as load increases (see figure 5.10 a).

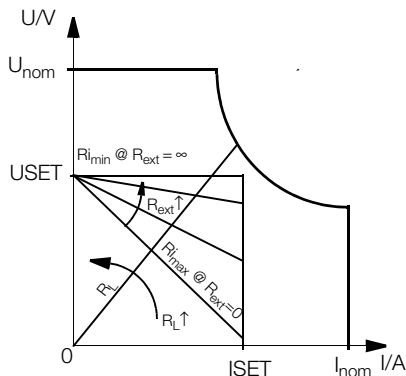

Figure 5.10 a Output Voltage Relative to Load

### Standardization

- The standardized curve shown in figure 5.10 applies to all device types.
- It is plain to see from the characteristic curve, which internal output resistance  $R_i$  results from which control resistance  $R_{ext}$ .  
 $R_i = R_{i_{max}} \cdot \text{display value}$

### Connection

- Wire the analog interface in accordance with figure 5.10 c.
- When wired as shown, the following relationship of internal resistance  $R_i$  to control resistance  $R_{ext}$  applies:

$$R_{ext} = \frac{30 \text{ k}\Omega \times U_{nom}}{R_i \times I_{nom}} - 24.4 \text{ k}\Omega$$

Example:  $U_{nom} = 40 \text{ V}$ ,  $I_{nom} = 6 \text{ A}$ ,  $R_i$  is  $0.5 \Omega$   
 $\implies R_{ext} = 376 \text{ k}\Omega$

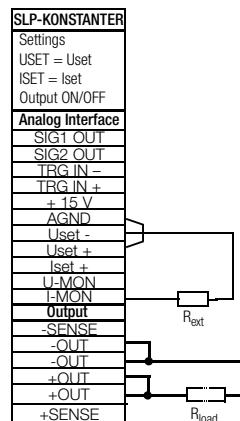

Figure 5.10 c Wiring for Varying Internal Resistance

- Table of  $R_{i_{max}}$  Values for all device types

Device Type	120-20	120-40	120-80	
$R_{i_{max}} / \Omega$	2.46	8.2	32.8	
Device Type	240-20	240-40	240-80	320-32
$R_{i_{max}} / \Omega$	1.23	4.1	16.4	2.19

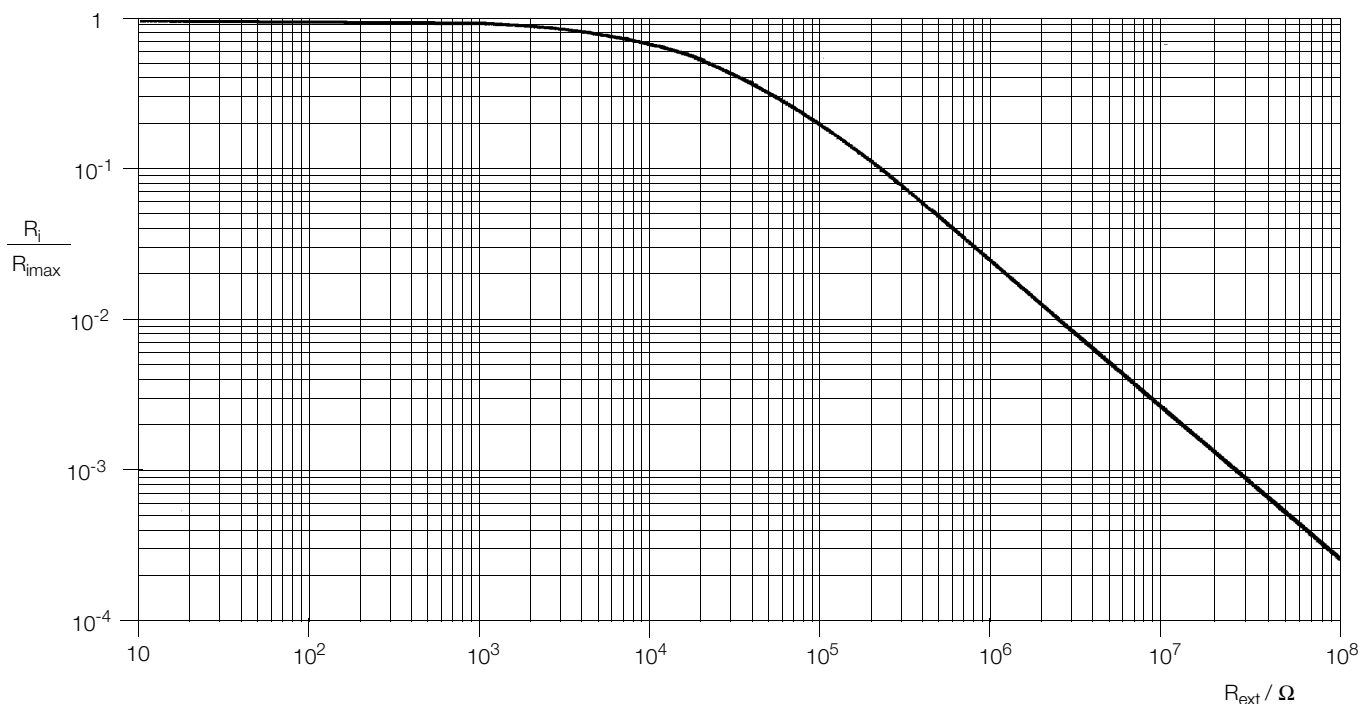

Figure 5.10 b Standardized curve for the determination of internal output resistance based upon a predefined control resistance

## 6 Accessories

### Mounting

Description	Note	Article No.
19" adapter 1 x 32 N	Required for installing one type 32 N ... device to a 19" rack Wight: 214 g (packed in plastic bag)	K990A
19" adapter 2 x 32 N	Required for installing two type 32 N ... devices to a 19" rack Wight: 50 g (packed in plastic bag)	K990B
Mains jumper cable, 0.4 m long	The cable includes a 10 A inlet connector and a 10 A socket for non-heating apparatus. It is used for looping mains power through when several devices are mechanically combined into a multi-channel unit. The resulting unit requires only one power cable. Wight: 102 g (packed in plastic bag)	K991A

## 7 Order Information

Description (abbreviated designation)	Type	Article No.
SLP 120-20	32 N 20 R 10	K220A*
SLP 120-40	32 N 40 R 6	K221A*
SLP 120-80	32 N 80 R 3	K222A*
SLP 240-20	32 N 20 R 20	K230A*
SLP 240-40	32 N 40 R 12	K231A*
SLP 240-80	32 N 80 R 6	K232A*
SLP 320-32	32 N 32 R 18	K234A*

\* 115 V variant available with appendix -S001

## 5 Repair and Replacement Parts Service, Calibration Center\* and Rental Instrument Service

When you need service, please contact:

GMC-I Service GmbH  
**Service Center**  
Thomas-Mann-Str. 20  
90471 Nuremberg, Germany  
Phone +49 911 817718-0  
Fax +49 911 817718-253  
E-Mail [service@gossenmetrawatt.com](mailto:service@gossenmetrawatt.com)  
[www.gmci-service.com](http://www.gmci-service.com)

This address is only valid in Germany. Please contact our representatives or subsidiaries for service in other countries.

### \* DAkkS Calibration Laboratory for Electrical Quantities D-K-15080-01-01 accredited per DIN EN ISO/IEC 17025:2005

Accredited quantities: direct voltage, direct current value, direct current resistance, alternating voltage, alternating current value, alternating current active power, alternating current apparent power, DC power, capacitance, frequency, temperature

### Competent Partner

GMC-I Messtechnik GmbH is certified in accordance with DIN EN ISO 9001:2008.

Our DAkkS calibration laboratory is accredited by the Deutsche Akkreditierungsstelle GmbH (National accreditation body for the Federal Republic of Germany) in accordance with DIN EN ISO/IEC 17025:2005 under registration number D-K-15080-01-01.

We offer a complete range of expertise in the field of metrology: from **test reports** and **factory calibration certificates**, right on up to **DAkkS calibration certificates**.

Our spectrum of offerings is rounded out with free test equipment management.

Our service department includes an **on-site DAkkS calibration bench**. If errors are discovered during calibration, our specialized personnel are capable of completing repairs using original replacement parts.

As a full service calibration lab, we can calibrate instruments from other manufacturers as well.

## 6 Product Support

When you need support, please contact:

GMC-I Messtechnik GmbH  
**Product Support Hotline**  
Phone +49 911 8602-0  
Fax +49 911 8602-709  
E-Mail [support@gossenmetrawatt.com](mailto:support@gossenmetrawatt.com)

## Recalibration

The respective measuring task and the stress to which your measuring instrument is subjected affect the ageing of the components and may result in deviations from the guaranteed accuracy.

If high measuring accuracy is required and the instrument is frequently used in field applications, combined with transport stress and great temperature fluctuations, we recommend a relatively short calibration interval of 1 year. If your measuring instrument is mainly used in the laboratory and indoors without being exposed to any major climatic or mechanical stress, a calibration interval of 2-3 years is usually sufficient.

During recalibration\* in an accredited calibration laboratory (DIN EN ISO/IEC 17025) the deviations of your instrument in relation to traceable standards are measured and documented. The deviations determined in the process are used for correction of the readings during subsequent application.

We are pleased to perform DAkkS or factory calibrations for you in our calibration laboratory. Please visit our website at [www.gossenmetrawatt.com](http://www.gossenmetrawatt.com) (→ Company → DAkkS Calibration Center *or* → FAQs → Calibration questions and answers).

By having your measuring instrument calibrated regularly, you fulfill the requirements of a quality management system per DIN EN ISO 9001.

\* Verification of specifications or adjustment services are not part of the calibration. For products from our factory, however, any necessary adjustment is frequently performed and the observance of the relevant specification is confirmed.

## Device Return and Environmentally Compatible Disposal

The instrument is a category 9 product (monitoring and control instrument) in accordance with ElektroG (German Electrical and Electronic Device Law). This device is subject to the RoHS directive. Furthermore, we make reference to the fact that the current status in this regard can be accessed on the Internet at [www.gossenmetrawatt.com](http://www.gossenmetrawatt.com) by entering the search term WEEE.

We identify our electrical and electronic devices in accordance with WEEE 2012/19/EU and ElektroG with the symbol shown to the right per DIN EN 50419.



These devices may not be disposed of with the trash. Please contact our service department regarding the return of old devices.

---

Edited in Germany • Subject to change without notice • A pdf version can be found on the internet

 **GOSSEN METRAWATT**  
GMC-I Messtechnik GmbH  
Südwestpark 15  
90449 Nürnberg • Germany

Phone +49 911 8602-111  
Fax +49 911 8602-777  
E-Mail [info@gossenmetrawatt.com](mailto:info@gossenmetrawatt.com)  
[www.gossenmetrawatt.com](http://www.gossenmetrawatt.com)