

Power storage devices - UPS-BAT/VRLA-WTR/24DC/13AH - 2320416

Please be informed that the data shown in this PDF Document is generated from our Online Catalog. Please find the complete data in the user's documentation. Our General Terms of Use for Downloads are valid (<http://download.phoenixcontact.com>)



Power storage device, lead AGM, VRLA technology, 24 V DC, 13 Ah, tool-free battery replacement, automatic detection, and communication with QUINT UPS-IQ

Product Features

- Tool-free battery replacement
- Communication with QUINT UPS IQ



Key commercial data

package_quantity	1
GTIN	4046356707701

Technical data

Dimensions

Width	178 mm
Height	176 mm
Depth	172 mm

Ambient conditions

Degree of protection	IP20
Ambient temperature (operation)	-40 °C ... 60 °C
Ambient temperature (storage/transport)	-40 °C ... 60 °C
Max. permissible relative humidity (operation)	≤ 95 %

Input data

Nominal input voltage	24 V DC
Buffer period	50 min (10 A)
Buffer period	10 min (40 A)

Output data

Output current	max. 45 A
Connection in parallel	15
Connection in series	No
Output fuse	2x 25 A

Power storage devices - UPS-BAT/VRLA-WTR/24DC/13AH - 2320416

Technical data

General

IQ technology	Yes
Disposal	Used batteries must not be thrown away with household waste, they should instead be disposed of in accordance with applicable national regulations. They can also be returned to Phoenix Contact or the manufacturer.
Net weight	10.8 kg
Memory medium	Pure lead AGM
Protection class	III
Mounting position	Horizontally, on a mounting plate
Standard - Electrical safety	EN 60950-1/VDE 0805 (SELV)
Shipbuilding approval	GL applied for
Standard – Electronic equipment for use in electrical power installations and their assembly into electrical power installations	EN 50178/VDE 0160 (PELV)
UL approvals	UL/C-UL listed UL 508
UL approvals	UL/C-UL Recognized UL 60950

classifications

eCl@ss

eCl@ss 4.0	27040702
eCl@ss 4.1	27040603
eCl@ss 5.0	27040603
eCl@ss 5.1	27040603
eCl@ss 6.0	27040603
eCl@ss 7.0	27040603
eCl@ss 8.0	27040603

ETIM

ETIM 3.0	EC001039
ETIM 4.0	EC000382
ETIM 5.0	EC000357

UNSPSC

UNSPSC 6.01	30211510
UNSPSC 7.0901	39121011
UNSPSC 11	39121011
UNSPSC 12.01	39121011
UNSPSC 13.2	39121011

approvals

Power storage devices - UPS-BAT/VRLA-WTR/24DC/13AH - 2320416

approvals

Approval details

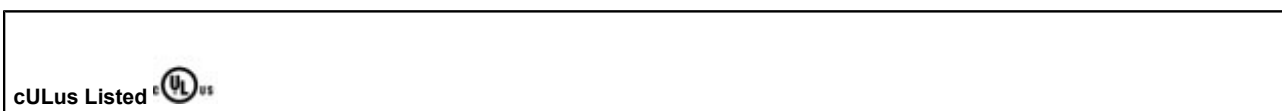
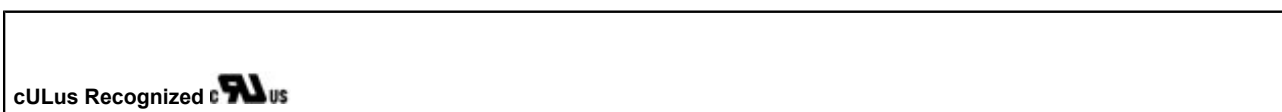
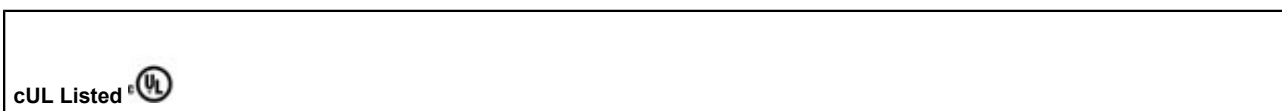
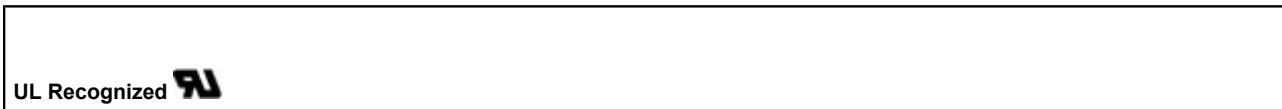

accessories

Mounting material

BATTERY MOUNTING KIT - 2320788



Drawings

Power storage devices - UPS-BAT/VRLA-WTR/24DC/13AH - 2320416

Block diagram

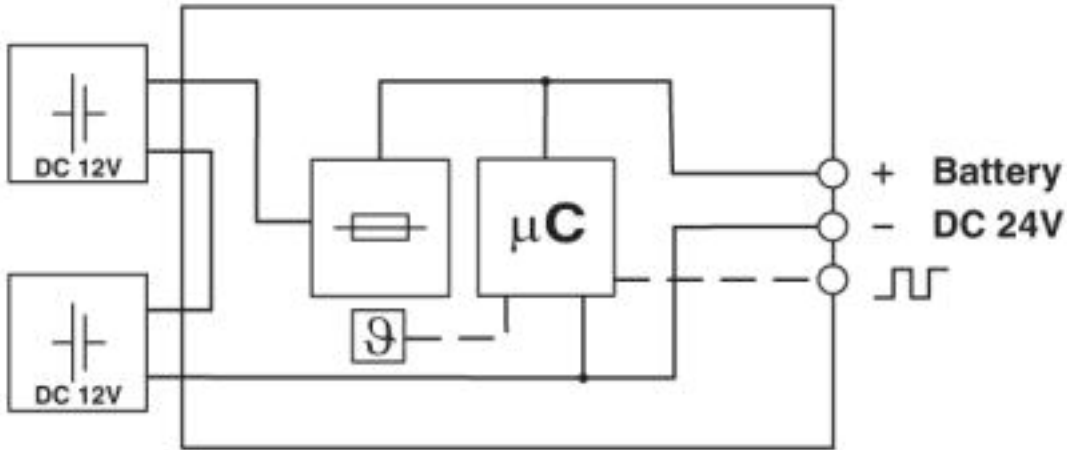

© Phoenix Contact 2013 - all rights reserved
<http://www.phoenixcontact.com>