

BENNING

MODEL: MM1-1 / MM1-2 / MM1-3

Service Information

The Service Information provides the following information:

- Precautions and safety information
- Specifications
- Basic maintenance (cleaning, replacing the battery and fuses)
- Performance test procedures
- Calibration and calibration adjustment procedures

TABLE OF CONTENTS	Page
Introduction	1
Precautions and Safety Information	1
Symbols	1
Safety	2
Specifications	3
General Specification	3
Voltage Specification	4
Current Specifications	4
Resistance, Diode, Frequency Specifications	5
Continuity, Capacitance, Temperature Specification	5
Physical and environment characteristics	7
Certification and compliance	7
Required Equipment	8
Basic Maintenance	9
Opening the Meter Case	9
Replacing the Battery	9
Testing Fuses	10
Replacing Fuses	10
Cleaning	10
Performance Tests	11
Testing the Display	11
Testing the Voltage Function	12
Testing the Resistance Function	13
Testing the Capacitance Function	13
Testing the Diode	14
Testing the amp (A) Function	14
Testing Current Function	14/15
Testing the Frequency	15
Testing the Temperature Function	16
Calibration	17/18
Calibrating DCV, ACV, DCA Functions	17/18

Introduction

Warning

To avoid shock or injury, do not perform the verification tests or calibration procedures described in the manual unless you are qualified to do so.

The information provided in this document is for the use of qualified personnel only.

Caution

The MM1-1, MM1-2, MM1-3 serials contain parts that can be damaged by static discharge. Follow the standard practices for handling static sensitive devices.

For additional information about BENNING GMBH & CO. KG. and its products, and services, visit BENNING GMBH & CO. KG. web site at:

www.benning.de

Precautions and Safety Information









Use the Meter only as described in the Users Manual. If you do not do so, the protection provided by the Meter may be impaired. Read the "Safety Information" page before servicing this product.

In this manual, a **Warning** identifies conditions and actions that pose hazard (s) to the user; a **Caution** identifies conditions and actions that may damage the Meter or the test instruments.

The Symbols

The symbols used on the Meter and in this manual are explained in Table A.

Table A. The Symbols

Symbol	Meaning
	Alternating signal
	Direct signal
	Refer to the manual, Important information.
	Take appropriate precautions. Hazardous voltage may be present.
	Battery
	Earth ground
	Fuse
	Double insulated
	Conforms to EU directives

SAFETY

Review the following safety precautions to avoid injury and prevent damage to this product or any products connected to it. To avoid potential hazards, use the product only as specified.

⚠ CAUTION: These statements identify conditions or practices that could result in damage to the equipment or other property.

⚠ WARNING: These statements identify conditions or practices that could result in personal injury or loss of life.

Specific precautions

Use proper Fuse. To avoid fire hazard, use only the fuse type and rating specified for this product.

Do not operate without covers. To avoid personal injury, do not apply any voltage or current to the product without covers in place.

Electric overload. Never apply a voltage to a connector on the product that is outside the range specified for that connector.

Avoid electric shock. To avoid injury or loss of life, do not connect or disconnect probes or test leads while they are connected to a voltage source.

Do not operate in wet/damp conditions. To avoid electric shock, do not operate this product in wet or damp conditions.

SPECIFICATIONS

All specifications are warranted unless noted typical and apply to the MM1-1, MM1-2, MM1-3. Stated accuracies are at 23°C±5°C at less than 80% relative humidity and without the battery indicator displayed.

General specifications

Characteristics	Description
Display count	3 1/2
Numeric update rate	1.5 times / sec
Polarity display	Automatic
Ovrange display	"OL" is displayed
Low voltage indicator	 is indicated
Automatic power-off time	Automatic backslit off = 10 minutes
Power source	1.5V×2 IEC LR03 or AAA size
Maximum input voltage	600V CAT III between V and COM
Maximum floating voltage	600V CAT III between any terminal and earth ground
Maximum input current	10A between A and COM
Maximum open circuit Voltage (current inputs)	600V between A and COM
Overload protection A connector	10A (500V) fast blow fuse
V connector	1100Vp V_{\sim} , V_{\equiv} , Ω , μA , μV , μs , μs , μs , μs , Hz, μA , °C, °F
Temperature Coefficient	0.15×(Spec. Accuracy) / °C, <18°C or >28°C
Battery Life	220 hours typical (alkaline)

Measurement Characteristics

Accuracy is \pm (% reading + number of digits) at $23^{\circ}\text{C} \pm 5^{\circ}\text{C}$, less than 80% R.H.

(1) DC Volts

Range	Resolution	Accuracy	Over voltage protection
200mV	100 μ V	\pm (0.5% reading + 2 digits)	DC 1000V
2V	1mV		
20V	10mV		
200V	100mV		
1000V	1V		

Input Impedance : 10M Ω (over 1000M Ω in 600mV range).

(2) AC Volts

Range	Resolution	Accuracy	Over voltage protection
200mV	0.1mV	Unspecified	750V rms
2V	1mV	\pm (1.5% reading + 5 digits)	
20V	10mV		
200V	100mV		
750V	1V		

Input Impedance : 10M Ω // less than 100pF.

Frequency Response : 50Hz~500Hz

AC Conversion Type : AC conversions are ac-coupled true rms responding, calibrated to the rms value sine wave input.

(3) DC Current

Range	Resolution	Accuracy	Voltage Burden
2A	1mA	\pm (1.0% reading + 2 digits)	2V max
10A	10mA		

Overload Protection: A input : 10A (500V)

(4) AC Current

Range	Resolution	Accuracy	Voltage Burden
2A	1mA	\pm (1.5% reading + 5 digits)* ¹	2V max
10A	10mA		

Frequency Response : 50Hz~500Hz

Overload Protection: A input : 10A (500V)

*¹ AC Conversion Type : Conversions type and additional specification are same as AC Voltage.

(5) Resistance

Range	Resolution	Accuracy	Over voltage protection
200Ω	0.1Ω	±(0.7% reading + 3 digits)	600V rms
2KΩ	1Ω		
20KΩ	10Ω		
200KΩ	100Ω		
2MΩ	1KΩ	±(1.0% reading + 3 digits)	
20MΩ*	10KΩ	±(1.5% reading + 3 digits)	

Open circuit Voltage : -1.3V approx.

* There is a little rolling less than ±2%

(6) Diode Check and Continuity

Range	Resolution	Accuracy	Max. Test Current	Max. Open Circuit Voltage
→	10mV	±(1.5% reading + 5 digits)*	1.5mA	2V

* For 0.4V ~ 0.8V

Overload Protection : 600V rms max.

Continuity : Built-in buzzer sounds when measured resistance is less than 270Ω and sound off when measured resistance is more than >850Ω

Between 270Ω to 850Ω the buzzer maybe sound or off either.

(7) Frequency

Range	Resolution	** Sensitivity	Accuracy	Overload protection
2000Hz	1Hz	100mV rms *	Frequency: 0.01% ± 2 digit	600V rms
20KHz	10Hz			
200KHz	100Hz			
2MHz	1KHz			
20MHz	10KHz			

* Less than 20Hz the sensitivity is 1.5V rms.

** Max. Sensitivity: <5 Vac rms

(8) Capacitance

Range	Resolution	Accuracy	Over voltage Protection
2nF	1pF	±(1.9% reading + 8 digits)	600V rms
20nF	10pF		
200nF	100pF		
2µF	1nF		
20µF	10nF		
200µF	100nF		
2mF*	1µF		

Overload Protection : 600V rms.

* <100 dgt of reading rolling.

(9) Temperature °C (for MM1-3 only)

Function	Range	Overload protection
-20°C ~ 0°C	±(2% reading + 4 digits)	600V rms
1°C ~ 100°C	±(1% reading + 3 digits)	
101°C ~ 500°C	±(2% reading + 3 digits)	
501°C ~ 800°C	±(3% reading + 2 digits)	

(10) Temperature °F (for MM1-3 only)

Function	Range	Overload protection
-4°F ~ 32°F	±(2% reading + 8 digits)	600V rms
33°F ~ 212°F	±(1% reading + 6 digits)	
213°F ~ 932°F	±(2% reading + 6 digits)	
933°F ~ 1472°F	±(3% reading + 4 digits)	

(11) Auto Power Off (APO)

If the meter idles for more than 10 minutes, the meter automatically turns the power off. When this happens, the state (non-logic measurement) of the meter is saved, the meter can be turned back on by pressing any switch or changing the rotary switch. If the meter is Re-Powered by pressing a switch, the LCD display the saved state, press the Hold switch to disable the hold state. The meter will alarm 15 seconds before automatically turning power off, any key press or rotary change will reset Auto-Power-Off.

(12) Disable Auto Power Off

In order to disable auto power off function, power up the meter whilst pressing down any switch other than the "Hold" switch.

Physical and Environmental Characteristics

Characteristics	Description
Dimensions (H×W×D)	34mm×74mm×156mm
Weight (with battery)	0.25Kg
Environmental characteristics	Description
Temperature operating	0 to +50°C
Non-Operating	-20 to +60°C
Humidity (operating)	<80% R.H.
Altitude Operating	2,000M (6560 ft.)
Non-Operating	12,300M (40354 ft.)
Vibration & shock Operating	MIL-T-28800E TYPE II Class 5 2.66gRMS, 5 to 500Hz, 3axes (10 minutes each)
Indoor Use	Indoor Use

Certifications and compliances

Safety	Designed to IEC 61010-1, UL 3111-1 and CSA specifications
Input rating	V / Ω: Category III 600 Volts A: Max 10A Fused
Over voltage category	CAT III: Distribution level mains, fixed installation. CAT II: Local level mains, appliances, portable equipment CAT I: Signal level, special equipment or parts of equipment, telecommunication, electronics.
Pollution Degree 2	Do not operate in environments where conductive Pollutants may be present.
EC Declaration of Conformity	Meets the intent of Directive 89/336/EEC for Electromagnetic Compatibility and Low Voltage Directive 73/23/EEC for product safety. Compliance was demonstrated to the following specifications as listed in the official Journal of the European Communities: En 55011 Class A: Radiated and Conducted Emissions. En 50082-1 Immunity: IEC 801-2 Electrostatic Discharge IEC 801-3 RF Radiated En 61010-1 Safety requirements for electrical equipment for measurement, control, and laboratory use.

Required Equipment

Required equipment is listed in Table B. If the recommended models are not available, equipment with equivalent specifications may be used.

Repairs or servicing should be performed only by qualified personnel.

Table B. Required Equipment

Equipment	Required Characteristics	Recommended Model
Calibrator	AC Voltage Range: 0 ~ 750V AC Accuracy: ±0.07% (Basic) Frequency Range: 40 ~ 1KHz Accuracy: ±2% DC Voltage Range: 0 ~ 1000V DC Accuracy: ±0.006% (Basic) Current Range: 0 ~ 10A (only for 72/73) Accuracy: AC (40Hz to 1KHz): ±0.08% (Basic) DC: ±0.02% (Basic) Frequency Source: 5.00Hz ~ 100MHz Accuracy: ±0.001% Amplitude: 0.5V p-p ~ 1.0V p-p (square wave) Accuracy: ±5% Resistance Range: 1Ω ~ 100MΩ Accuracy: ±0.03% (Basic) Capacitance Range: 1pF ~ 10mF Accuracy: ±0.10% (Basic) Temperature Range: -200°C ~ 1200°C Accuracy: ±0.3%°C (Basic)	Fluke 5500 or Wavetek 9100 Calibrator or equipment

Basic Maintenance

⚠Warning

To avoid shock, remove the test leads and any input signals before opening the case or replacing the battery or fuses.

Opening the Meter Case

⚠Caution

To avoid unintentional shock circuit, always place the uncovered Meter assembly on a protective surface. When the case of the Meter is open, circuit connections are exposed.

To open the Meter case, refer to Figure 1 and do the following:

1. Disconnect test leads from any live source, turn rotary switch to OFF, and remove the test leads from the front terminals.
2. Remove the battery door by using a flat-blade screwdriver to turn the battery door screws turn counter-clockwise.
3. The case bottom is secured to the case top by four screws and two internal snaps (at the LCD end). Using a Phillips-head screwdriver, remove the four screws.

Replacing the Battery

The Meter is powered 1.5V x 2 batteries.

To replace the battery, refer to Figure

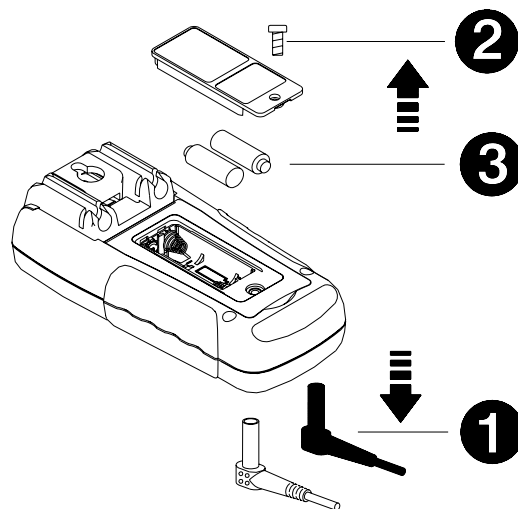

Testing Fuses (only for MM1-2 / MM1-3)

To test the internal fuses of the meter.

1. Turn the rotary selector switch to the Ω position.
2. To test FS1, plug a test lead into V Ω Hz input terminal, and touch the probe to the A input terminal. The display should indicate between 0.0 to 0.2 Ω . FS1 (10A 500V) (Bussmann BBS-1 recommended). If display reads higher than 0.2 Ω , replace the fuse.

Fuse Replacement (only for MM1-2 / MM1-3)

Refer to the following figure to replace fuse:

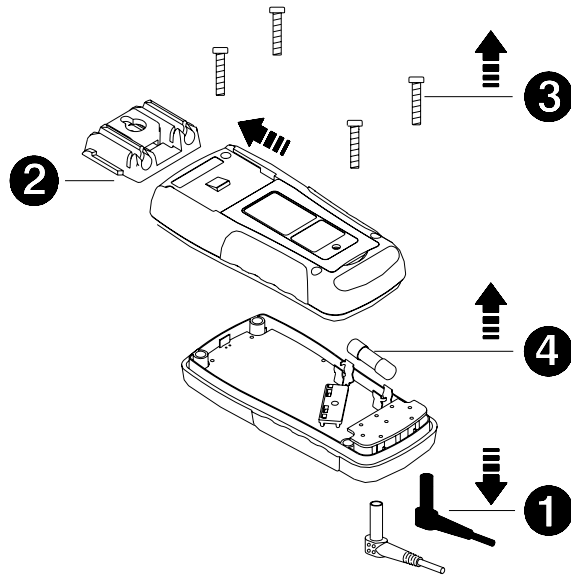

Use only a fuse with the amperage, interrupt, voltage, and speed rating specified.
Fuse rating: 10A, 500V, Fast

Replacing Fuses (only for MM1-2 / MM1-3)

⚠ Warning

To avoid electrical shock, remove the test leads and any input signals before replacing the battery or fuses. To prevent damage or injury, INSTALL ONLY quick acting fuses with the following Amp/Volt current interrupt rating:

FS1 Fuse: 10A, 500V, FAST. Minimum interrupt rating 10,000A

Cleaning

⚠ Warning

To avoid electrical shock or damage to the Meter, never allow water inside the case. To avoid damaging the Meter's housing, never apply solvents to the Meter.

Performance Tests

The following performance tests verify the complete operability of the Meter and check the accuracy of each Meter function against the Meter's specifications.

Accuracy specifications are valid for a period of one year after calibration, when measured at an operating temperature of 18°C to 28°C and A maximum of 80% relative humidity.

To perform the following tests, it is not necessary to open the case, no Adjustments are necessary. Merely make the required connections, apply the designated inputs, and determine if the reading on the Meter display falls within the acceptable range indicated.

If the Meter fails any of these tests, it needs calibration adjustment or repair.

Testing the Display

Press "HOLD" key while turning the Meter on from the "OFF" position to hold the display in the Display Test Mode. Compare the display with the example in Figure 2. Turn off the meter to escape the test mode.

LCD Graphics MM1-3



Figure 2 Display Test

Testing the Voltage Function

To verify accuracy in the AC and DC voltage ranges, do the following:

1. Turn the rotary switch to “**V~**” position.
2. Connect the Calibrator to the **VΩ** and **COM** inputs on the Meter.
3. Set the Calibrator for the voltage and frequency from step 1 to 8 in Table 1.
4. Compare the reading on the Meter display with the display reading shown in Table 1.
5. If the display reading falls outside of the range shown in Table 1, the Meter does not meet specification.

Table 1 AC Voltage Test :

Step	Input	Frequency	Reading
1	1.500V	50Hz	1.472V to 1.528V
2	1.500V	300Hz	1.472V to 1.528V
3	15.00V	50Hz	14.72V to 15.28V
4	15.00V	500Hz	14.72V to 15.28V
5	150.0V	50Hz	147.2V to 152.8V
6	150.0V	500Hz	147.2V to 152.8V
7	750V	50Hz	734V to 766V
8	750V	500Hz	734V to 766V

6. Turn the rotary switch to “**V=**” position.
7. Set the calibration for the voltage from step 1 to 6 in Table 2.
8. Compare the reading on the Meter display with the display reading shown in Table 2.
9. If the display reading falls outside of the range shown in Table 2, the meter does not meet specification.

Table 2 DC Voltage Test:

Step	Input	Reading
1	150.0mV	149.0V to 151.0V
2	-150.0mV	-149.0V to -151.0V
3	1.500V	1.490V to 1.510V
4	15.00V	14.90V to 15.10V
5	150.0V	149.0V to 151.0V
6	990V	983V to 997V

Testing the Resistance Function

To verify the accuracy of the resistance function, do the following:

1. Connect the Calibrator to **VΩHz** and **COM** on the Meter.
2. Turn the rotary switch to Ω.
3. Apply the inputs for step 1-6 in Table 3.
4. Compare the Meter display readings to the display readings in Table 3.
5. If the display reading falls outside of the range shown in Table 3, the Meter does not meet specification.

Table 3 Ω Resistance Test:

Step	Source	Reading
1	150.0Ω	148.6Ω to 151.4Ω
2	1.500KΩ	1.486KΩ to 1.514KΩ
3	15.00KΩ	14.86KΩ to 15.14KΩ
4	150.0KΩ	148.6KΩ to 151.4KΩ
5	1.500MΩ	1.482MΩ to 1.518MΩ
6	15.00MΩ	14.74MΩ to 15.26MΩ

* Lead resistance on the 400Ω range is not included in error.

Testing the Capacitance Function

The Meter measures capacitance by charging the capacitor with a known Direct current, measuring the resultant voltage, and calculating the capacitance. If the same capacitance is measured on an impedance bridge, a different reading may result. This variance is likely to be Greater at higher frequencies.

To verify the accuracy of the capacitance measuring function, do the Following :

1. Apply the Capacitor to the **VΩHz** and **COM** inputs on the Meter. For steps 1 through 7 in Table 4.
2. Turn the rotary switch $\overline{||}$.
3. Compare the reading on the Meter display to the reading in Table 4.

Note : The meter selects the proper range automatically. Each measurement takes about one second per range, 2mF takes about 4.5 seconds.

4. If the display reading falls outside of the range shown in Table 4, the Meter does not meet specification.

Table 4 Capacitance Test:

Step	Source	Reading
1	1.500nF	1.463nF to 1.537nF
2	15.00nF	14.63nF to 15.37nF
3	150.0nF	146.3nF to 153.7nF
4	1.500μF	1.463μF to 1.537μF
5	15.00μF	14.63μF to 15.37μF
6	150.0μF	146.3μF to 153.7μF
7	1.500mF	1.463mF to 1.537mF

Checking the Diode Test Function

To check the diode test function, do the following:

1. Connect the Calibrator to the **VΩHz** and **COM** inputs on the Meter.
2. Turn the rotary switch to 
3. Apply 3.000V DC.
The meter display should read approx. 3.000V dc.
4. Built-in buzzer sounds when measured resistance is less than 270Ω and sound off when measured resistance is more than >850Ω
Between 270Ω to 850Ω the buzzer maybe sound or off either.

Testing the amp (A) Function

To verify the accuracy of AC current measurement functions, do the following:

1. Connect the Calibrator to the **A** and **COM** inputs on the Meter.
2. Turn the rotary switch to A.
3. Apply the inputs for steps 1-4 in Table 5.
4. For each input, compare the readings on the Meter display to the reading in Table 5.
5. If the display reading falls outside of the range shown in the Table 5, the meter does not meet specification.

Table 5 AC Current Test:

Step	Source	Frequency	Reading
1	1.500A	50Hz	14.72A to 15.28A
2	1.500A	500Hz	1.472A to 1.528A
3	10.00A	50Hz	9.80A to 10.20A
4	10.00A	500Hz	9.80A to 10.20A

6. Turn the rotary switch to **A $\overline{\text{=}}$** .
7. Apply the inputs for steps 1-2 in Table 6.
8. For each input, compare the reading on the Meter display to the reading in Table 6.
9. If the display reading falls outside of the range shown in Table 6, the meter does not meet specification.

Table 6 DC Current Test:

Step	Source	Reading
1	1.500A	1.483A to 1.517A
2	10.00A	9.88A to 10.12A

Testing the Frequency Function

To verify the accuracy of the Meter's frequency function, do the following:

1. Connect the Calibrator to the **V Ω** and **COM** inputs on the Meter.
Note: The accuracy of the Calibrator's frequency function must be appropriate for the specified accuracy of the Meter.
2. Set the rotary switch to Hz.
3. Set the Function Generator for the square wave voltage and frequency for steps 1-5 of Table 7.
4. Compare the reading on the Meter display with the display reading shown in Table 7.
5. If the display reading falls outside of the range shown in Table 7, the Meter does not meet specification.

Table 7 Frequency Test:

Step	Source	Level	Reading
1	1500Hz	100mV rms	1498Hz to 1502Hz
2	15.00KHz	100mV rms	14.98KHz to 15.02KHz
3	150.0KHz	100mV rms	149.8KHz to 150.2KHz
4	1.500MHz	250mV rms	1.498MHz to 1.502MHz
5	15.00MHz	1V rms	14.98MHz to 15.02MHz

* Max. level: <5 Vac rms

Testing the Temperature °C Function (for BENNING MM 1-3 Only)

To verify the accuracy of the Meter's Temperature function, do the following:

1. Connect the Calibrator to the **V Ω Hz** and **COM** via K-type wire and T-V adaptor (TA-300).
2. Set the rotary switch to °C.
3. Set the Calibrator for steps 1-8 of table 8.
4. Compare the reading on the Meter display with the display reading shown in Table 8.
 If the display reading falls outside of the range shown in Table 8, the Meter does not meet specification.

Table 8 Temperature °C Test (for MM1-3 Only):

Input		Reading
Step	Temperature	
1	-10°C	-14°C to -6°C
2	0°C	-4°C to 4°C
3	10°C	7°C to 13°C
4	50°C	47°C to 53°C
5	100°C	96°C to 104°C
6	250°C	242°C to 258°C
7	500°C	487°C to 513°C
8	800°C	774°C to 826°C

Testing the Temperature °F Function (for MM1-3 Only)

To verify the accuracy of the Meter's Temperature function, do the following:

1. Connect the Calibrator to the **VΩHz** and **COM** via K-type wire and T-V adaptor (TA-300).
2. Set the rotary switch to °F.
3. Set the Calibrator for steps 1-8 of table 9.
4. Compare the reading on the Meter display with the display reading shown in Table 9.

If the display reading falls outside of the range shown in Table 9, the Meter does not meet specification.

Table 9 Temperature °F Test (for MM1-3 Only):

Input		Reading
Step	Temperature	
1	14°F	6°F to 22°F
2	32°F	24°F to 40°F
3	50°F	44°F to 56°F
4	122°F	115°F to 129°F
5	212°F	204°F to 220°F
6	482°F	466°F to 498°F
7	932°F	907°F to 957°F
8	1472°F	1424°F to 1520°F

Calibration Procedure

Recalibrate your meter:

It is recommended that the multimeter be calibrated once each year.

1. Perform calibration at an ambient temperature of $23^{\circ}\text{C}\pm 2^{\circ}\text{C}$ and a relative humidity of 75% or less.
2. Disconnect the test leads and turn the meter off. Remove the test leads from the front terminals.
3. Position the meter face down. Remove the three screws from the case bottom.
4. Lift the end of the case bottom until it gently unsnaps from the case top at the end nearest the LCD.
5. Lift the circuit board from the case top. Do not remove the screws from the circuit board.

(A) DCV Calibration (Adjust VR2)

6. Set the circuit board rotary switch "arrow" to the "V $\overline{=}$ " position of circuit board.
7. Set the output of DC calibrator for $150.0\text{V}\pm 0.02\%$ and connect to V $\Omega\mu\text{AHz}$ \rightarrow and COM input terminals on meter.
8. Using a small flat-tipped screwdriver adjust the potentiometer VR2 until the display reads 149.9 or 150.1.
9. Disconnect the DC calibrator from the meter.

(B) ACV Calibration (Adjust VR1)

10. Set the circuit board rotary switch "arrow" to the "V \sim " position of circuit board.
11. Set the output of AC calibration for 150.0V 100Hz and connect to V $\Omega\mu\text{AHz}$ \rightarrow and COM input terminals on meter.
12. Using a small flat-tipped screwdriver adjust the potentiometer VR1 until the display reads 149.9 or 150.1.
13. Disconnect the AC calibrator from the meter.

(C) DCA Calibration (Adjust VR66 、 VR67 、 VR68) (for MM1-2 / MM1-3 Only)

14. Set the circuit board rotary switch "arrow" to the "A" position circuit board.
15. Using a small flat-tipped screwdriver adjust potentiometer VR67 until the display reads +0.001 or -0.001.
16. Set the output of DCA calibrator for 1.5A and connect to A and COM input terminals on meter.
17. Using a small flat-tipped screwdriver adjust potentiometer VR66 until the display reads 1.499 or 1.501.
18. Repeat 15~17.
19. Set the output of DCA calibrator for 10.0A and input terminals on meter.
20. Using a small flat-tipped screwdriver adjust potentiometer VR68 until the display reads 9.99A or 10.00A.
21. Disconnect the DCA calibrator from the meter.

(E) $^{\circ}\text{C}$ Calibration (Adjust VR3 、 VR5) (For MM1-3 Only)

22. Set the clamp meter at $^{\circ}\text{C}$ function.
23. Set the output of thermocouple calibrator for 0°C K Type and connect to the meter.
24. Using a small flat-tipped screwdriver adjust the potentiometer VR3 until the display reads 1 or -1 .
25. Set the output of thermocouple calibrator for 500°C K Type.
26. Using a small flat-tipped screwdriver adjust the potentiometer VR5 until the display reads 499 or 501.

(F) °F Calibration (Adjust VR4 、 VR6) (For MM1-3 Only)

27. Set the clamp meter at °F function.
28. Set the output of thermocouple calibrator for 0°F K Type and connect the bead probe to K Type socket on meter.
29. Using a small flat-tipped screwdriver adjust potentiometer VR4 until the display reads 1 or -1.
30. Set the output of thermocouple calibration for 932°F K Type.
31. Using a small flat-tipped screwdriver adjust potentiometer VR6 until the display reads 931 or 933.
32. Disconnect the thermocouple calibrator from the meter.

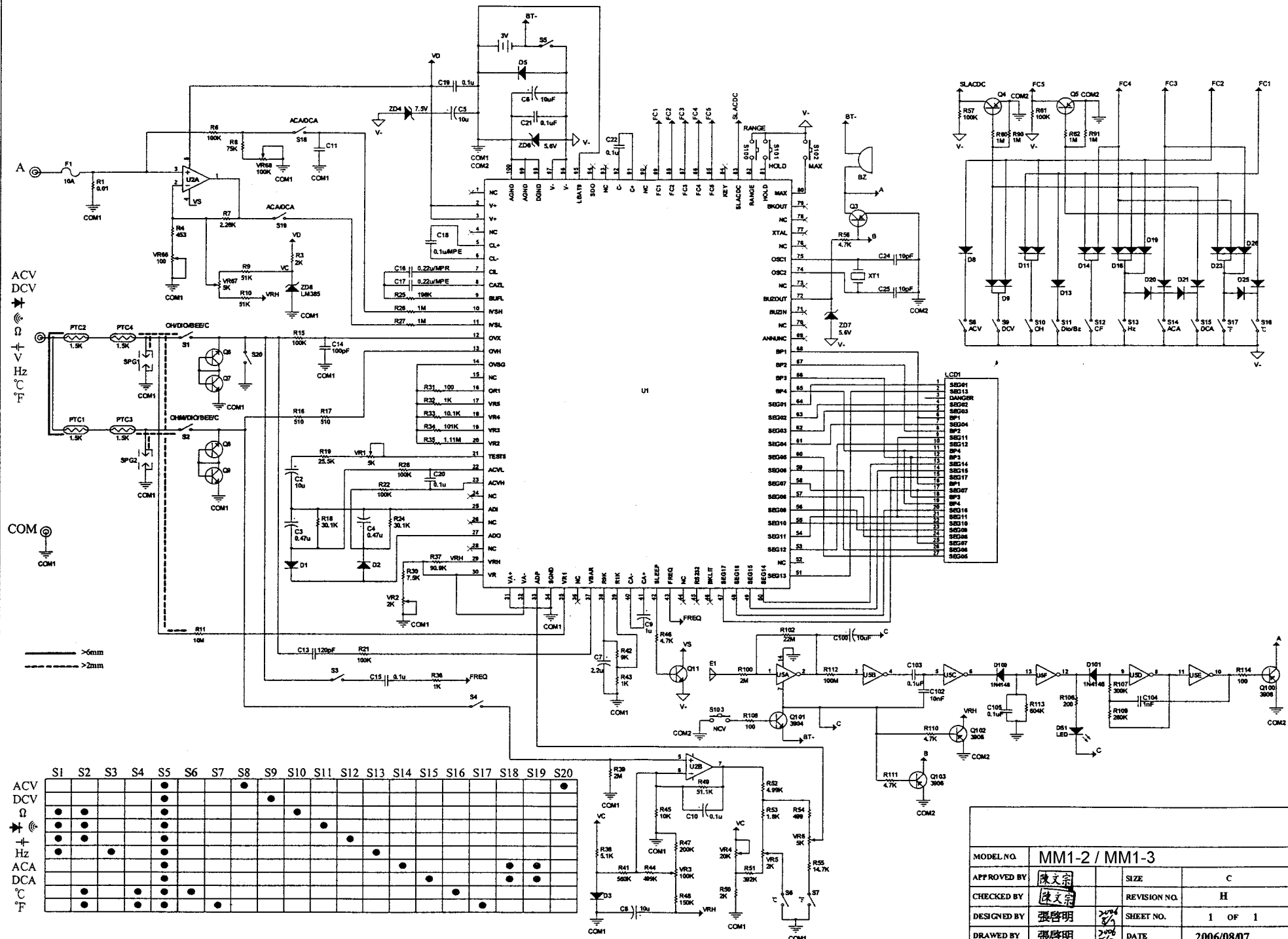

ACV
DCV
Ω
Hz
ACA
DCA
°C
°F

COM

— >6mm
- - - >2mm

ACV	S1	S2	S3	S4	S5	S6	S7	S8	S9	S10	S11	S12	S13	S14	S15	S16	S17	S18	S19	S20	
DCV																					
Ω																					
Hz																					
ACA																					
DCA																					
°C																					
°F																					

MODEL NO.	MM1-2 / MM1-3		
APPROVED BY	陳文宗	SIZE	C
CHECKED BY	陳文宗	REVISION NO.	H
DESIGNED BY	張啓明	SHEET NO.	1 OF 1
DRAWN BY	張啓明	DATE	2006/08/07

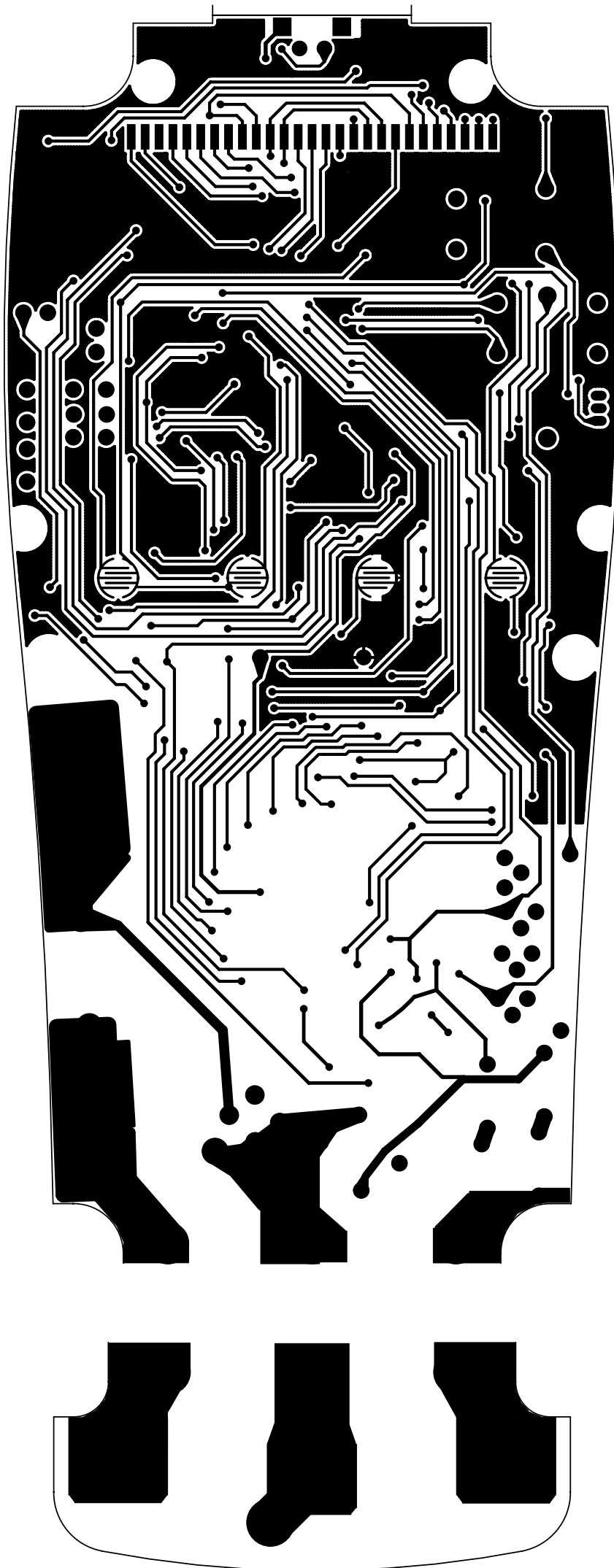

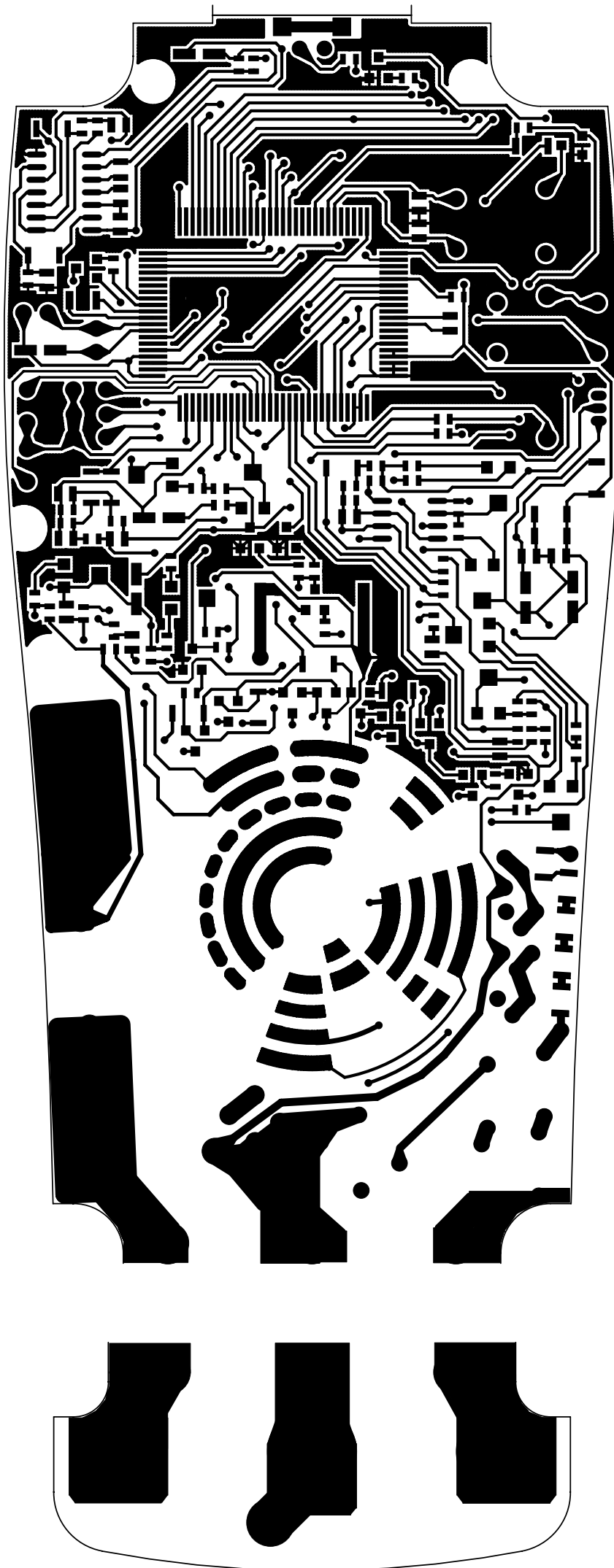

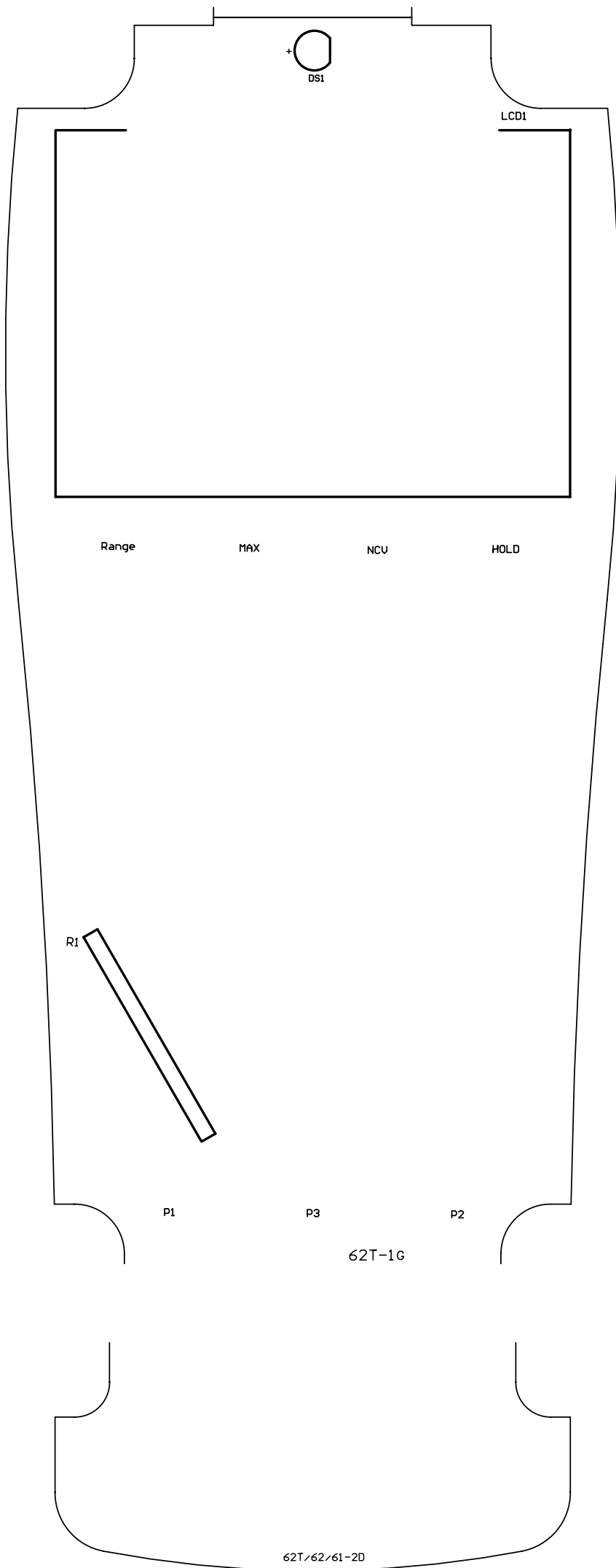

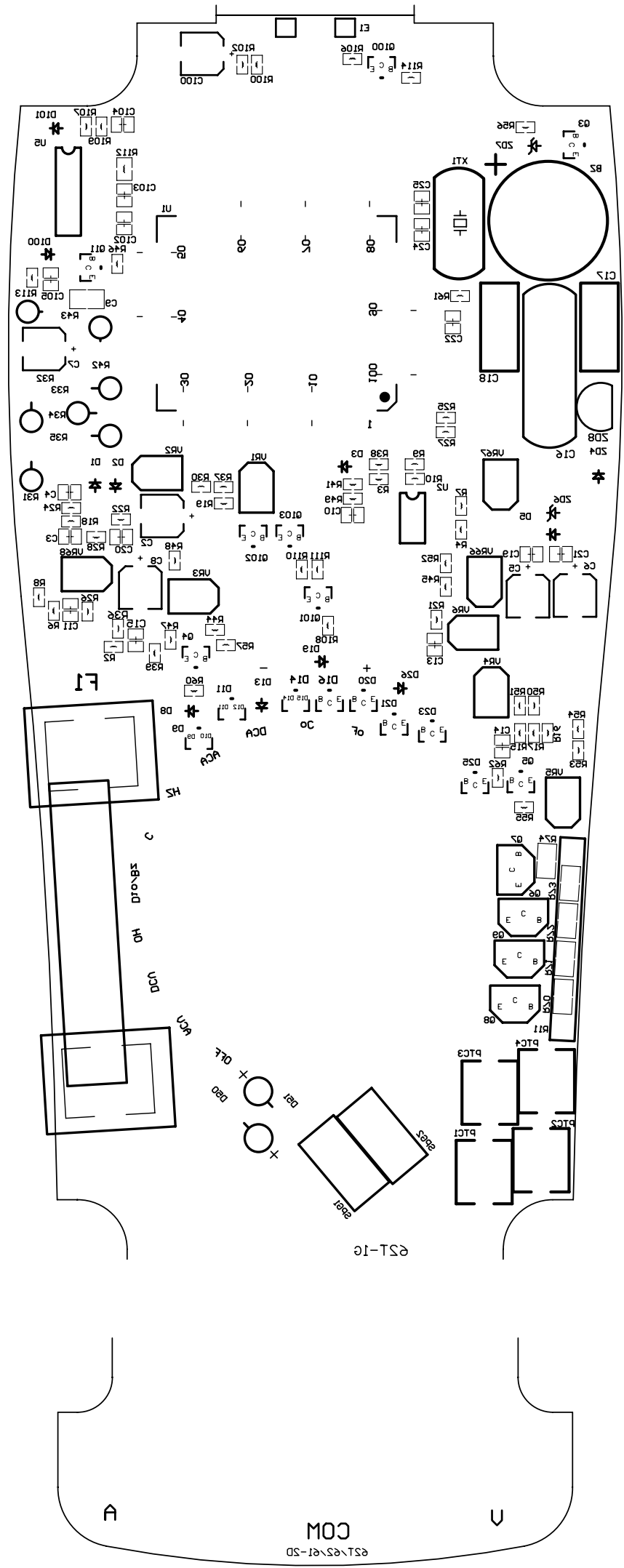

COM

A

U

RST-1G

