

FEATURES

Highly Luminous Ultra Bright Yellow LED Lamp

AllnGaP Technology Chip

Dominant Wavelength 590 nm

Water Clear Epoxy Package

Lens Size 5mm

Viewing Angles $2\theta \frac{1}{2} = 15^\circ$ (Reference)

Stand-Off Options

Package Dimensions

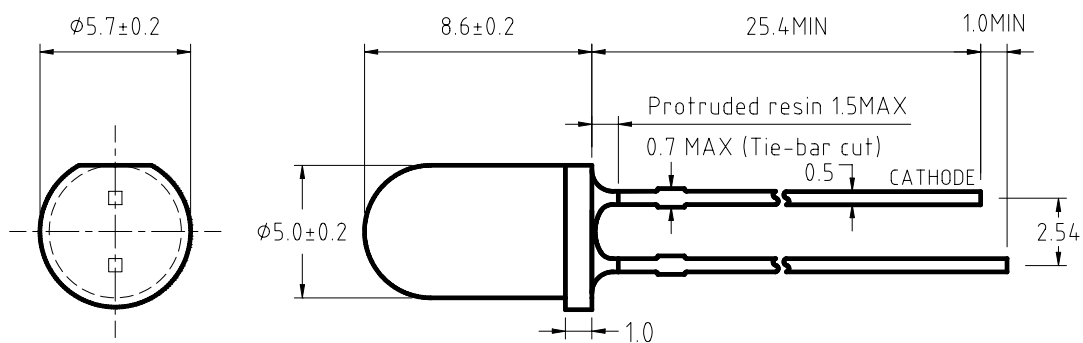

Notes:

1. All dimensions are in millimeters (inches).
2. Tolerance ± 0.25 (0.01") mm unless otherwise noted.
3. Protruded resin under flange is 1.0mm (0.04") max.
4. Lead spacing is measured where the leads emerge from the package
5. Specifications are subject to change without notice.

Delivery

- Bulk, 500 pieces per bag standard
- Ammo or Reel available upon request

Absolute Maximum Ratings at Ta = 25°C

Continuous Forward Current	I_f	50 mA
Power Dissipation	P_d	120 mW
Peak Forward Current	I_{fp}	100 mA
Reverse Voltage	V_r	5 V
Operating Temperature	T_{op}	-35 ~ +85°C
Storage Temperature	T_{stg}	-40 ~ +100°C
Soldering Temperature	T_{sd}	260°C / 5 Sec

Remarks: I_{fp} = Pulse Width 10 ms, Duty Ratio 1/10

Electrical / Optical Characteristics at Ta = 25°C

Parameter	Symbol	Min	Typ	Max	Unit	Test Condition
Forward Voltage	V_f	1.9	2.1	2.4	V	$I_f = 20$ mA
Reverse Current	I_r			50	μ A	$V_R = 5$ V
Luminous Intensity	I_v	7200		15700	mcd	$I_f = 20$ mA
Peak Wavelength	λ_p		593		nm	$I_f = 20$ mA
Dominant Wavelength	λ_d	585	590	595	nm	$I_f = 20$ mA
Spectrum Radiation Bandwidth	Δ_λ		15		nm	$I_f = 20$ mA

Iv Ranks / Luminous Intensity Bin Limits (IF=20mA)

Bin Name	Min	Max
X	7200	9300
Y	9300	12000
Z	12000	15700

Tolerance of each bin limit is $\pm 15\%$

Color /Wave Length Ranks (IF=20mA)

Bin Name	Wave Length (nm)
1	585~587.5
2	587.5~590
3	590~592.5
4	592.5~595

Tolerance for each bin limit is ± 1 nm

Electrical / Optical Characteristics Diagram at Ta = 25°C

Forward Current vs. Forward Voltage

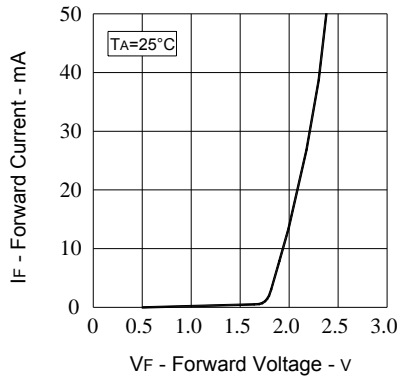

Relative Intensity vs. Forward Current

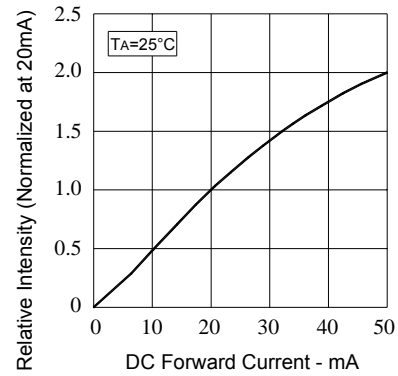

Forward Current vs. Ambient Temperature

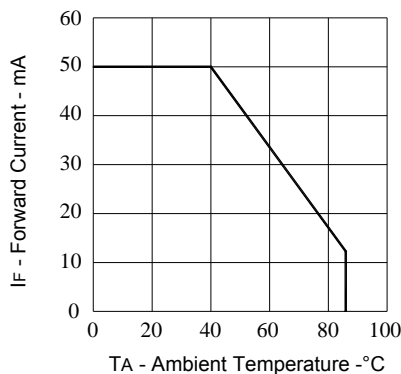

Relative Intensity vs. Wavelength

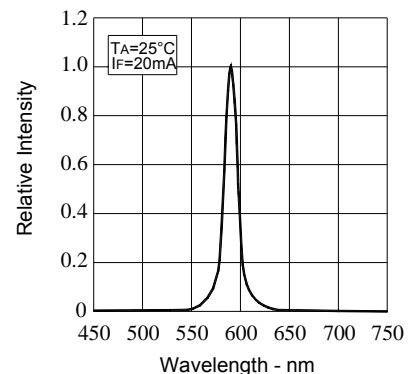

Notes:

1. One delivery will include up to three color ranks and two luminous intensity ranks of the products. The quantity-ratio of the ranks is decided by Yoldal.
2. All data showing in this product specification are measured by proper experiment conditions and instruments. However, those data may be different due to variations of testing instruments and conditions.

Soldering Conditions - Lamp Type LED

- Solder the LED no closer than 3mm from the base of the epoxy bulb. Soldering beyond the base of the tie bar is recommended
- Recommended soldering conditions

Dip Soldering	
Pre-Heat	120 Max.
Pre-Heat Time	60 sec. Max.
Solder Bath Temperature	260 Max.
Dipping Time	5 sec. Max.
Dipping Position	No lower than 3mm from the base of the epoxy bulb.

Hand Soldering		
	5Ø Series	Others (Including Lead-Free Solder)
Temperature	300 Max.	350 Max.
Soldering time	3 sec. Max.	3 sec. Max.
Position	No closer than 3mm from the base of the epoxy bulb.	No closer than 3mm from the base of the epoxy bulb.

- Do not apply any stress to the lead, particularly when heated
- The LEDs must not be repositioned after soldering
- After soldering the LEDs, the epoxy bulb should be protected from mechanical shock or vibration until the LEDs return to room temperature.
- Direct soldering onto a PC board should be avoided. Mechanical stress to the resin may be caused by the PC board warping or from the clinching and cutting of the leadframes. When it is absolutely necessary, the LEDs may be mounted in this fashion, but, the User will assume responsibility for any problems. Direct soldering should only be done after testing has confirmed that no damage, such as wire bond failure or resin deterioration, will occur. YOLDAL's LEDs should not be soldered directly to double sided PC boards because the heat will deteriorate the epoxy resin.
- When it is necessary to clamp the LEDs to prevent soldering failure, it is important to minimize the mechanical stress on the LEDs.
- Cut the LED leadframes at room temperature. Cutting the leadframes at high temperatures may cause LED failure.



Electrostatic Sensitive Devices