

Date	Name	Description	No
			△

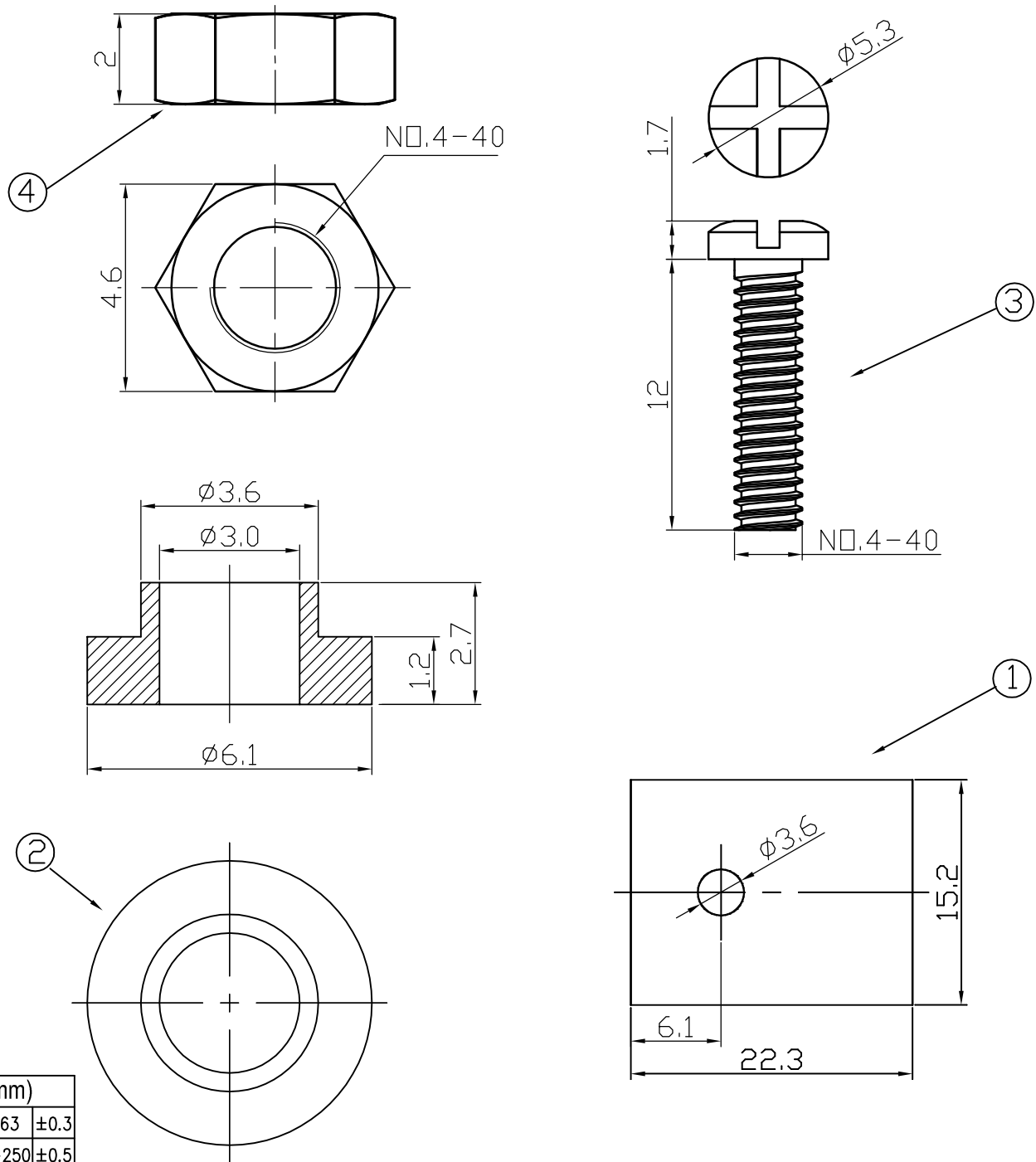

Tolerance(mm)			
1<	±0.1	16-63	±0.3
1-4	±0.1	63-250	±0.5
4-16	±0.2		

A4

4	Nut	1	Fe	4.6*2*NO.4-40		
3	Screw	1	Fe	NO.4-40*12		
2	Bushing	1	PA#66			
1	Ceramics	1	Ceramics	t=1.5mm		
No	Description	Q'ty	Material	Specification	Finish	Remark
Drawn	Checked	Approved	SCI BOM No.		Model Name	Mounting Hardware
黃衛東			Customer No.		Model No.	A18-9E
2009/10/13			Unit	mm	SHIN CHIN INDUSTRIAL CO., LTD.	
						REV. 0