



# **PIC16F716**

## **Data Sheet**

8-bit Flash-based Microcontroller  
with A/D Converter and  
Enhanced Capture/Compare/PWM

---

---

**Note the following details of the code protection feature on Microchip devices:**

- Microchip products meet the specification contained in their particular Microchip Data Sheet.
- Microchip believes that its family of products is one of the most secure families of its kind on the market today, when used in the intended manner and under normal conditions.
- There are dishonest and possibly illegal methods used to breach the code protection feature. All of these methods, to our knowledge, require using the Microchip products in a manner outside the operating specifications contained in Microchip's Data Sheets. Most likely, the person doing so is engaged in theft of intellectual property.
- Microchip is willing to work with the customer who is concerned about the integrity of their code.
- Neither Microchip nor any other semiconductor manufacturer can guarantee the security of their code. Code protection does not mean that we are guaranteeing the product as "unbreakable."

Code protection is constantly evolving. We at Microchip are committed to continuously improving the code protection features of our products. Attempts to break microchip's code protection feature may be a violation of the Digital Millennium Copyright Act. If such acts allow unauthorized access to your software or other copyrighted work, you may have a right to sue for relief under that Act.

---

Information contained in this publication regarding device applications and the like is intended through suggestion only and may be superseded by updates. It is your responsibility to ensure that your application meets with your specifications. No representation or warranty is given and no liability is assumed by Microchip Technology Incorporated with respect to the accuracy or use of such information, or infringement of patents or other intellectual property rights arising from such use or otherwise. Use of Microchip's products as critical components in life support systems is not authorized except with express written approval by Microchip. No licenses are conveyed, implicitly or otherwise, under any intellectual property rights.

#### Trademarks

The Microchip name and logo, the Microchip logo, dsPIC, KEELoQ, MPLAB, PIC, PICmicro, PICSTART, PRO MATE and PowerSmart are registered trademarks of Microchip Technology Incorporated in the U.S.A. and other countries.


FilterLab, microID, MXDEV, MXLAB, PICMASTER, SEEVAL and The Embedded Control Solutions Company are registered trademarks of Microchip Technology Incorporated in the U.S.A.

Accuron, Application Maestro, dsPICDEM, dsPICDEM.net, ECAN, ECONOMONITOR, FanSense, FlexROM, fuzzyLAB, In-Circuit Serial Programming, ICSP, ICEPIC, microPort, Migratable Memory, MPASM, MPLIB, MPLINK, MPSIM, PICC, PICkit, PICDEM, PICDEM.net, PowerCal, PowerInfo, PowerMate, PowerTool, rLAB, rPIC, Select Mode, SmartSensor, SmartShunt, SmartTel and Total Endurance are trademarks of Microchip Technology Incorporated in the U.S.A. and other countries.

Serialized Quick Turn Programming (SQTP) is a service mark of Microchip Technology Incorporated in the U.S.A.

All other trademarks mentioned herein are property of their respective companies.

© 2003, Microchip Technology Incorporated, Printed in the U.S.A., All Rights Reserved.

 Printed on recycled paper.



*Microchip received QS-9000 quality system certification for its worldwide headquarters, design and wafer fabrication facilities in Chandler and Tempe, Arizona in July 1999 and Mountain View, California in March 2002. The Company's quality system processes and procedures are QS-9000 compliant for its PICmicro® 8-bit MCUs, KEELoQ® code hopping devices, Serial EEPROMs, microperipherals, non-volatile memory and analog products. In addition, Microchip's quality system for the design and manufacture of development systems is ISO 9001 certified.*

## 8-bit Flash-based Microcontroller with A/D Controller and Enhanced Capture/Compare PWM

### Microcontroller Core Features:

- High-performance RISC CPU
- Only 35 single-word instructions to learn
  - All single-cycle instructions except for program branches which are two-cycle
- Operating speed: DC - 20 MHz clock input  
DC - 200 ns instruction cycle
- Interrupt capability  
(up to 7 internal/external interrupt sources)
- 8-level deep hardware stack
- Direct, Indirect and Relative Addressing modes

### Special Microcontroller Features

- Power-on Reset (POR)
- Power-up Timer (PWRT) and Oscillator Start-up Timer (OST)
- Watchdog Timer (WDT) with its own on-chip RC oscillator for reliable operation
- Dual level Brown-out Reset circuitry
  - 2.5 V<sub>BOR</sub> (Typical)
  - 4.0 V<sub>BOR</sub> (Typical)
- Programmable code protection
- Power saving Sleep mode
- Selectable oscillator options
- Fully static design
- In-Circuit Serial Programming™ (ICSP™)

### CMOS Technology

- Wide operating voltage range:
  - Industrial: 2.0V to 5.5V
  - Extended: 3.0V to 5.5V
- High Sink/Source Current 25/25 mA
- Wide temperature range:
  - Industrial: -40°C to 85°C
  - Extended: -40°C to 125°C

### Low-Power Features:

- Standby Current:
  - 100 nA @ 2.0V, typical
- Operating Current:
  - 14 µA @ 32 kHz, 2.0V, typical
  - 120 µA @ 1 MHz, 2.0V, typical
- Watchdog Timer Circuit:
  - 1 µA @ 2.0V, typical
- Timer1 Oscillator Current:
  - 3.0 µA @ 32 kHz, 2.0V, typical

### Peripheral Features:

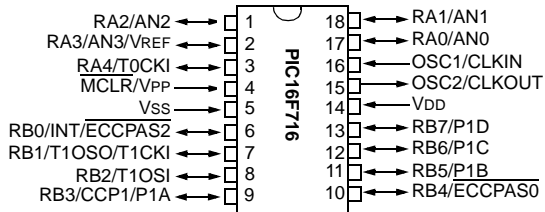
- Timer0: 8-bit timer/counter with 8-bit prescaler
- Timer1: 16-bit timer/counter with prescaler can be incremented during Sleep via external crystal/clock
- Timer2: 8-bit timer/counter with 8-bit period register, prescaler and postscaler
- Enhanced Capture, Compare, PWM module:
  - Capture is 16-bit, max. resolution is 12.5 ns
  - Compare is 16-bit, max. resolution is 200 ns
  - PWM maximum resolution is 10-bit
  - Enhanced PWM:
    - Single, Half-Bridge and Full-Bridge modes
    - Digitally programmable dead-band delay
    - Auto-shutdown/restart
- 8-bit multi-channel Analog-to-Digital converter
- 13 I/O pins with individual direction control
- Programmable weak pull-ups on PORTB

Device	Memory		I/O	8-bit A/D (ch)	Timers 8/16	PWM (outputs)	VDD Range
	Flash	Data					
PIC16F716	2048 x 14	128 x 8	13	4	2/1	1/2/4	2.0V - 5.5V

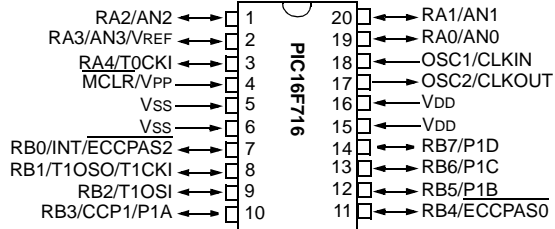
# PIC16F716

## Pin Diagrams

### 18-pin PDIP, SOIC



### 20-pin SSOP



## Table of Contents

1.0 Device Overview .....	5
2.0 Memory Organization .....	7
3.0 I/O Ports .....	19
4.0 Timer0 Module .....	27
5.0 Timer1 Module .....	29
6.0 Timer2 Module .....	31
7.0 Enhanced Capture/Compare/PWM (ECCP) Module.....	33
8.0 Analog-to-Digital Converter (A/D) Module.....	49
9.0 Special Features of the CPU.....	55
10.0 Instruction Set Summary.....	71
11.0 Development Support.....	85
12.0 Electrical Characteristics.....	91
13.0 DC and AC Characteristics Graphs and Tables.....	107
14.0 Packaging Information.....	109
Appendix A: Revision History.....	113
Appendix B: Conversion Considerations .....	113
Appendix C: Migration from Base-line to MID-RANGE Devices .....	114
On-Line Support.....	115
Systems Information and Upgrade Hot Line .....	115
Reader Response .....	116
Index .....	117
Product Identification System .....	123

## TO OUR VALUED CUSTOMERS

It is our intention to provide our valued customers with the best documentation possible to ensure successful use of your Microchip products. To this end, we will continue to improve our publications to better suit your needs. Our publications will be refined and enhanced as new volumes and updates are introduced.

If you have any questions or comments regarding this publication, please contact the Marketing Communications Department via E-mail at [docerrors@mail.microchip.com](mailto:docerrors@mail.microchip.com) or fax the **Reader Response Form** in the back of this data sheet to (480) 792-4150. We welcome your feedback.

### Most Current Data Sheet

To obtain the most up-to-date version of this data sheet, please register at our Worldwide Web site at:

<http://www.microchip.com>

You can determine the version of a data sheet by examining its literature number found on the bottom outside corner of any page. The last character of the literature number is the version number, (e.g., DS30000A is version A of document DS30000).

### Errata

An errata sheet, describing minor operational differences from the data sheet and recommended workarounds, may exist for current devices. As device/documentation issues become known to us, we will publish an errata sheet. The errata will specify the revision of silicon and revision of document to which it applies.

To determine if an errata sheet exists for a particular device, please check with one of the following:

- Microchip's Worldwide Web site; <http://www.microchip.com>
- Your local Microchip sales office (see last page)
- The Microchip Corporate Literature Center; U.S. FAX: (480) 792-7277

When contacting a sales office or the literature center, please specify which device, revision of silicon and data sheet (include literature number) you are using.

### Customer Notification System

Register on our web site at [www.microchip.com/cn](http://www.microchip.com/cn) to receive the most current information on all of our products.

# PIC16F716

---

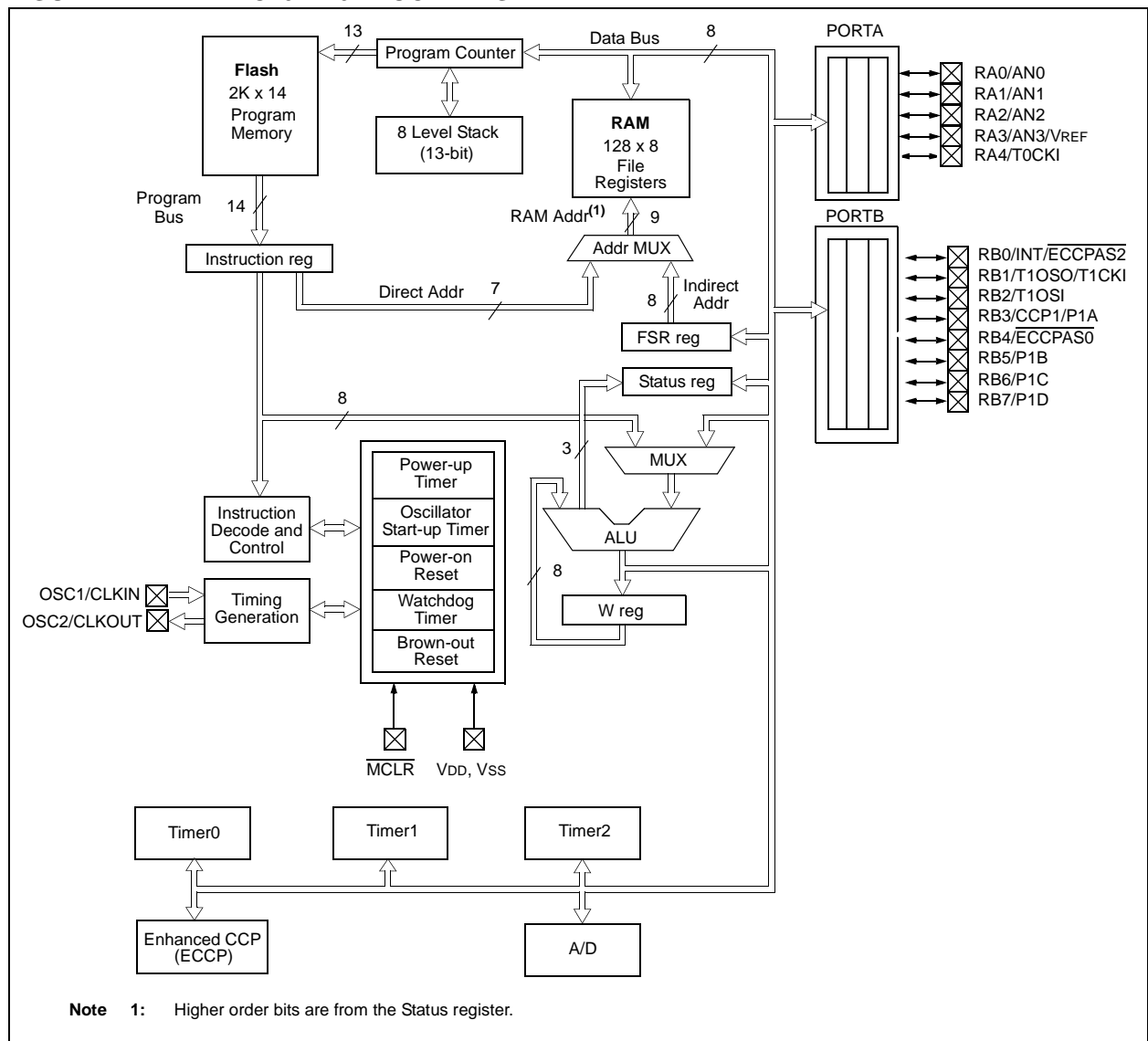
NOTES:

## 1.0 DEVICE OVERVIEW

This document contains device specific information for the PIC16F716. Additional information may be found in the PICmicro® Mid-Range Reference Manual, (DS33023), which may be obtained from your local Microchip Sales Representative or downloaded from the Microchip web site ([www.microchip.com](http://www.microchip.com)). The Reference Manual should be considered a complementary document to this data sheet, and is highly recommended reading for a better understanding of the device architecture and operation of the peripheral modules.

Figure 1-1 is the block diagram for the PIC16F716 device. The pinouts are listed in Table 1-1.

**FIGURE 1-1: PIC16F716 BLOCK DIAGRAM**



# PIC16F716

**TABLE 1-1: PIC16F716 PINOUT DESCRIPTION**

Name	Function	Input Type	Output Type	Description
MCLR/VPP	MCLR	ST	—	Master clear (Reset) input. This pin is an active low Reset to the device.
	VPP	P	—	Programming voltage input
OSC1/CLKIN	OSC1	XTAL	—	Oscillator crystal input
	CLKIN	CMOS	—	External clock source input
	CLKIN	ST	—	RC Oscillator mode
OSC2/CLKOUT	OSC2	XTAL	—	Oscillator crystal output. Connects to crystal or resonator in Crystal Oscillator mode.
	CLKOUT	—	CMOS	In RC mode, OSC2 pin outputs CLKOUT which has 1/4 the frequency of OSC1, and denotes the instruction cycle rate.
RA0/AN0	RA0	TTL	CMOS	Bidirectional I/O
	AN0	AN	—	Analog Channel 0 input
RA1/AN1	RA1	TTL	CMOS	Bidirectional I/O
	AN1	AN	—	Analog Channel 1 input
RA2/AN2	RA2	TTL	CMOS	Bidirectional I/O
	AN2	AN	—	Analog Channel 2 input
RA3/AN3/VREF	RA3	TTL	CMOS	Bidirectional I/O
	AN3	AN	—	Analog Channel 3 input
	VREF	AN	—	A/D reference voltage input
RA4/T0CKI	RA4	ST	OD	Bidirectional I/O. Open drain when configured as output.
	T0CKI	ST	—	Timer0 external clock input
RB0/INT/ECCPAS2	RB0	TTL	CMOS	Bidirectional I/O. Programmable weak pull-up.
	INT	ST	—	External Interrupt
	ECCPAS2	ST	—	ECCP Auto-Shutdown pin
RB1/T1OSO/T1CKI	RB1	TTL	CMOS	Bidirectional I/O. Programmable weak pull-up.
	T1OSO	—	XTAL	Timer1 oscillator output. Connects to crystal in Oscillator mode.
	T1CKI	ST	—	Timer1 external clock input
RB2/T1OSI	RB2	TTL	CMOS	Bidirectional I/O. Programmable weak pull-up.
	T1OSI	XTAL	—	Timer1 oscillator input. Connects to crystal in Oscillator mode.
RB3/CCP1/P1A	RB3	TTL	CMOS	Bidirectional I/O. Programmable weak pull-up.
	CCP1	ST	CMOS	Capture1 input, Compare1 output, PWM1 output.
	P1A	—	CMOS	PWM P1A output
RB4/ECCPAS0	RB4	TTL	CMOS	Bidirectional I/O. Programmable weak pull-up. Interrupt-on-change.
	ECCPAS0	ST	—	ECCP Auto-Shutdown pin
RB5/P1B	RB5	TTL	CMOS	Bidirectional I/O. Programmable weak pull-up. Interrupt-on-change.
	P1B	—	CMOS	PWM P1B output
RB6/P1C	RB6	TTL	CMOS	Bidirectional I/O. Programmable weak pull-up. Interrupt-on-change. ST input when used as ICSP programming clock.
	P1C	—	CMOS	PWM P1C output
RB7/P1D	RB7	TTL	CMOS	Bidirectional I/O. Programmable weak pull-up. Interrupt-on-change. ST input when used as ICSP programming data.
	P1D	—	CMOS	PWM P1D output
Vss	Vss	P	—	Ground reference for logic and I/O pins.
VDD	VDD	P	—	Positive supply for logic and I/O pins.

**Legend:** I = Input      AN = Analog input or output      OD = Open drain  
 O = Output      TTL = TTL compatible input      ST = Schmitt Trigger input with CMOS levels  
 P = Power      XTAL = Crystal      CMOS = CMOS compatible input or output



## 2.0 MEMORY ORGANIZATION

There are two memory blocks in the PIC16F716 PICmicro<sup>®</sup> microcontroller device. Each block (program memory and data memory) has its own bus so that concurrent access can occur.

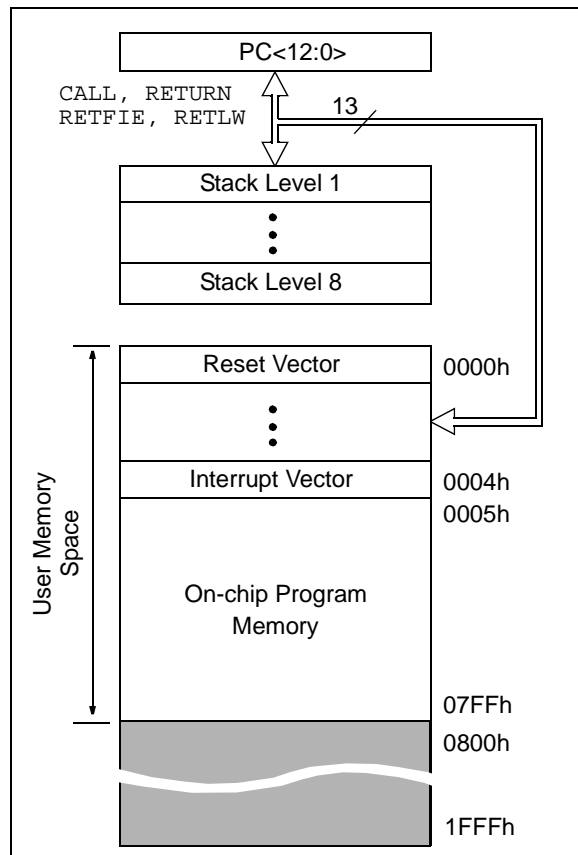
Additional information on device memory may be found in the PICmicro<sup>®</sup> Mid-Range Reference Manual, (DS33023).

### 2.1 Program Memory Organization

The PIC16F716 has a 13-bit program counter capable of addressing an 8K x 14 program memory space. The PIC16F716 has 2K x 14 words of program memory. Accessing a location above the physically implemented address will cause a wrap-around.

The Reset vector is at 0000h and the interrupt vector is at 0004h.

**FIGURE 2-1: PROGRAM MEMORY MAP AND STACK OF PIC16F716**



### 2.2 Data Memory Organization

The data memory is partitioned into multiple banks which contain the General Purpose Registers (GPR) and the Special Function Registers (SFR). Bits RP1 and RP0 of the Status register are the bank select bits.

RP1:RP0 <sup>(1)</sup> (status<6:5>)	Bank
00	0
01	1
10	2 <sup>(2)</sup>
11	3 <sup>(2)</sup>

**Note 1:** Maintain Status bit 6 clear to ensure upward compatibility with future products.

**2:** Not implemented

Each bank extends up to 7Fh (128 bytes). The lower locations of each bank are reserved for the Special Function Registers. Above the Special Function Registers are General Purpose Registers, implemented as static RAM. All implemented banks contain Special Function Registers. The upper 16 bytes of GPR space and some "high use" Special Function Registers in Bank 0 are mirrored in Bank 1 for code reduction and quicker access.

# PIC16F716


## 2.2.1 GENERAL PURPOSE REGISTER FILE

The register file can be accessed either directly or indirectly through the File Select Register FSR (Section 2.5 “Indirect Addressing, INDF and FSR Registers”).

**FIGURE 2-2: REGISTER FILE MAP**

File Address	File Address	File Address
00h	INDF <sup>(1)</sup>	80h
01h	TMR0	81h
02h	PCL	82h
03h	STATUS	83h
04h	FSR	84h
05h	PORTA	85h
06h	PORTB	86h
07h		87h
08h		88h
09h		89h
0Ah	PCLATH	8Ah
0Bh	INTCON	8Bh
0Ch	PIR1	8Ch
0Dh		8Dh
0Eh	TMR1L	8Eh
0Fh	TMR1H	8Fh
10h	T1CON	90h
11h	TMR2	91h
12h	T2CON	92h
13h		93h
14h		94h
15h	CCPR1L	95h
16h	CCPR1H	96h
17h	CCP1CON	97h
18h	PWM1CON	98h
19h	ECCPAS	99h
1Ah		9Ah
1Bh		9Bh
1Ch		9Ch
1Dh		9Dh
1Eh	ADRES	9Eh
1Fh	ADCON0	9Fh
20h	General Purpose Registers 80 Bytes	General Purpose Registers 32 Bytes
6Fh		A0h
		BFh
		C0h
		EFh
70h	16 Bytes	Accesses 70-7Fh
7Fh		F0h
		FFh

Bank 0                      Bank 1

 Unimplemented data memory locations, read as '0'.

**Note 1:** Not a physical register.

## 2.2.2 SPECIAL FUNCTION REGISTERS

The Special Function Registers are registers used by the CPU and peripheral modules for controlling the desired operation of the device. These registers are implemented as static RAM. A list of these registers is given in Table 2-1.

The Special Function Registers can be classified into two sets; core (CPU) and peripheral. Those registers associated with the core functions are described in detail in this section. Those related to the operation of the peripheral features are described in detail in that peripheral feature section.

**TABLE 2-1: SPECIAL FUNCTION REGISTER SUMMARY BANK 0**

Address	Name	Bit 7	Bit 6	Bit 5	Bit 4	Bit 3	Bit 2	Bit 1	Bit 0	Value on: POR, BOR	Page	
00h	INDF <sup>(1)</sup>	Addressing this location uses contents of FSR to address data memory (not a physical register)								0000 0000	18	
01h	TMR0	Timer0 module's register								xxxx xxxx	27	
02h	PCL <sup>(1)</sup>	Program Counter's (PC) Least Significant Byte								0000 0000	17	
03h	STATUS <sup>(1)</sup>	IRP <sup>(4)</sup>	RP1 <sup>(4)</sup>	RP0	$\overline{TO}$	$\overline{PD}$	Z	DC	C	0001 1xxx	11	
04h	FSR <sup>(1)</sup>	Indirect data memory address pointer								xxxx xxxx	18	
05h	PORTA <sup>(5,6)</sup>	—	—	— <sup>(7)</sup>	PORTA Data Latch when written: PORTA pins when read						--xx 0000	19
06h	PORTB <sup>(5,6)</sup>	PORTB Data Latch when written: PORTB pins when read								xxxx xxxx	21	
07h-09h	—	Unimplemented								—		
0Ah	PCLATH <sup>(1,2)</sup>	—	—	—	Write Buffer for the upper 5 bits of the Program Counter					---0 0000	17	
0Bh	INTCON <sup>(1)</sup>	GIE	PEIE	T0IE	INTE	RBIE	T0IF	INTF	RBIF	0000 000x	13	
0Ch	PIR1	—	ADIF	—	—	—	CCP1IF	TMR2IF	TMR1IF	-0-- 0000	15	
0Dh	—	Unimplemented								—		
0Eh	TMR1L	Holding register for the Least Significant Byte of the 16-bit TMR1 register								xxxx xxxx	29	
0Fh	TMR1H	Holding register for the Most Significant Byte of the 16-bit TMR1 register								xxxx xxxx	29	
10h	T1CON	—	—	T1CKPS1	T1CKPS0	T1OSCEN	$\overline{T1SYNC}$	TMR1CS	TMR1ON	--00 0000	29	
11h	TMR2	Timer2 module's register								0000 0000	31	
12h	T2CON	—	TOUTPS3	TOUTPS2	TOUTPS1	TOUTPS0	TMR2ON	T2CKPS1	T2CKPS0	-000 0000	31	
13h-14h	—	Unimplemented								—		
15h	CCPR1L	Capture/Compare/PWM Register 1 (LSB)								xxxx xxxx	34	
16h	CCPR1H	Capture/Compare/PWM Register 1 (MSB)								xxxx xxxx	34	
17h	CCP1CON	P1M1	P1M0	DC1B1	DC1B0	CCP1M3	CCP1M2	CCP1M1	CCP1M0	0000 0000	33	
18h	PWM1CON	PRSEN	PDC6	PDC5	PDC4	PDC3	PDC2	PDC1	PDC0	0000 0000	46	
19h	ECCPAS	ECCPASE	ECCPAS2	— <sup>(8)</sup>	ECCPAS0	PSSAC1	PSSAC0	PSSBD1	PSSBD0	00-0 0000	46	
1Ah-1Dh	—	Unimplemented								—		
1Eh	ADRES	A/D Result Register								xxxx xxxx	49	
1Fh	ADCON0	ADCS1	ADCS0	CHS2	CHS1	CHS0	$\overline{GO/DONE}$	— <sup>(7)</sup>	ADON	0000 0000	49	

**Legend:** x = unknown, u = unchanged, c = value depends on condition, - = unimplemented, read as '0', Shaded locations are unimplemented, read as '0'.

- Note**
- 1: These registers can be addressed from either bank.
  - 2: The upper byte of the program counter is not directly accessible. PCLATH is a holding register for PC<12:8> whose contents are transferred to the upper byte of the program counter.
  - 3: Other (non Power-up) Resets include: external Reset through  $\overline{MCLR}$  and the Watchdog Timer Reset.
  - 4: The IRP and RP1 bits are reserved. Always maintain these bits clear.
  - 5: On any device Reset, these pins are configured as inputs.
  - 6: This is the value that will be in the port output latch.
  - 7: Reserved bits, do not use.
  - 8: ECCPAS1 bit is not used on PIC16F716.

# PIC16F716

**TABLE 2-2: SPECIAL FUNCTION REGISTER SUMMARY BANK 1**

Address	Name	Bit 7	Bit 6	Bit 5	Bit 4	Bit 3	Bit 2	Bit 1	Bit 0	Value on: POR, BOR	Page
80h	INDF <sup>(1)</sup>	Addressing this location uses contents of FSR to address data memory (not a physical register)								0000 0000	18
81h	OPTION_REG	RBP $\bar{U}$	INTEDG	T0CS	T0SE	PSA	PS2	PS1	PS0	1111 1111	12
82h	PCL <sup>(1)</sup>	Program Counter's (PC) Least Significant Byte								0000 0000	17
83h	STATUS <sup>(1)</sup>	IRP <sup>(4)</sup>	RP1 <sup>(4)</sup>	RP0	$\bar{T}O$	$\bar{P}D$	Z	DC	C	0001 1xxx	11
84h	FSR <sup>(1)</sup>	Indirect data memory address pointer								xxxx xxxx	18
85h	TRISA	—	—	— <sup>(7)</sup>	PORTA Data Direction Register					--11 1111	19
86h	TRISB	PORTB Data Direction Register								1111 1111	21
87h-89h	—	Unimplemented								—	
8Ah	PCLATH <sup>(1,2)</sup>	—	—	—	Write Buffer for the upper 5 bits of the Program Counter					---0 0000	17
8Bh	INTCON <sup>(1)</sup>	GIE	PEIE	T0IE	INTE	RBIE	T0IF	INTF	RBIF	0000 000x	13
8Ch	PIE1	—	ADIE	—	—	—	CCP1IE	TMR2IE	TMR1IE	-0-- -000	14
8Dh	—	Unimplemented								—	
8Eh	PCON	—	—	—	—	—	—	$\bar{P}OR$	$\bar{B}OR$	---- --q $\bar{q}$	16
8Fh-91h	—	Unimplemented								—	
92h	PR2	Timer2 Period Register								1111 1111	32, 36
93h-9Eh	—	Unimplemented								—	
9Fh	ADCON1	—	—	—	—	—	PCFG2	PCFG1	PCFG0	---- -000	50

**Legend:** x = unknown, u = unchanged, q = value depends on condition, - = unimplemented, read as '0'. Shaded locations are unimplemented, read as '0'.

- Note**
- 1: These registers can be addressed from either bank.
  - 2: The upper byte of the program counter is not directly accessible. PCLATH is a holding register for PC<12:8> whose contents are transferred to the upper byte of the program counter.
  - 3: Other (non Power-up) Resets include: external Reset through  $\bar{M}CLR$  and the Watchdog Timer Reset.
  - 4: The IRP and RP1 bits are reserved. Always maintain these bits clear.
  - 5: On any device Reset, these pins are configured as inputs.
  - 6: This is the value that will be in the port output latch.
  - 7: Reserved bits, do not use.

## 2.2.2.1 Status Register

The Status register, shown in Register 2-1, contains the arithmetic status of the ALU, the Reset status and the bank select bits for data memory.

The Status register can be the destination for any instruction, as with any other register. If the Status register is the destination for an instruction that affects the Z, DC or C bits, then the write to these three bits is disabled. These bits are set or cleared according to the device logic. Furthermore, the  $\overline{TO}$  and  $\overline{PD}$  bits are not writable. Therefore, the result of an instruction with the Status register as destination may be different than intended.

For example, `CLRF STATUS` will clear the upper-three bits and set the Z bit. This leaves the Status register as `000u u1uu` (where u = unchanged).

It is recommended, therefore, that only `BCF`, `BSF`, `SWAPF` and `MOVWF` instructions are used to alter the Status register because these instructions do not affect the Z, C or DC bits from the Status register. For other instructions, not affecting any Status bits, see the "Instruction Set Summary."

**Note 1:** The PIC16F716 does not use bits IRP and RP1 (STATUS<7:6>). Maintain these bits clear to ensure upward compatibility with future products.

**2:** The C and DC bits operate as a borrow and digit borrow bit, respectively, in subtraction. See the `SUBLW` and `SUBWF` instructions for examples.

### REGISTER 2-1: STATUS REGISTER (ADDRESS: 03h, 83h)

R/W-0	R/W-0	R/W-0	R-1	R-1	R/W-x	R/W-x	R/W-x	
IRP <sup>(1)</sup>	RP1 <sup>(1)</sup>	RP0	$\overline{TO}$	$\overline{PD}$	Z	DC	C	
bit 7								bit 0

- bit 7 **IRP:** Register Bank Select bit (used for indirect addressing)<sup>(1)</sup>  
 1 = Bank 2, 3 (100h – 1FFh)  
 0 = Bank 0, 1 (00h – FFh)
- bit 6-5 **RP1<sup>(1)</sup>:RP0:** Register Bank Select bits (used for direct addressing)  
 01 = Bank 1 (80h – FFh)  
 00 = Bank 0 (00h – 7Fh)  
 Each bank is 128 bytes
- bit 4  **$\overline{TO}$ :** Time-out bit  
 1 = After power-up, `CLRWDT` instruction or `SLEEP` instruction  
 0 = A WDT time-out occurred
- bit 3  **$\overline{PD}$ :** Power-down bit  
 1 = After power-up or by the `CLRWDT` instruction  
 0 = By execution of the `SLEEP` instruction
- bit 2 **Z:** Zero bit  
 1 = The result of an arithmetic or logic operation is zero  
 0 = The result of an arithmetic or logic operation is not zero
- bit 1 **DC:** Digit carry/borrow bit (`ADDWF`, `ADDLW`, `SUBLW`, `SUBWF` instructions) (for borrow the polarity is reversed)  
 1 = A carry-out from the 4th low order bit of the result occurred  
 0 = No carry-out from the 4th low order bit of the result
- bit 0 **C:** Carry/borrow bit (`ADDWF`, `ADDLW`, `SUBLW`, `SUBWF` instructions)<sup>(2)</sup>  
 1 = A carry-out from the Most Significant bit of the result occurred  
 0 = No carry-out from the Most Significant bit of the result occurred
- Note 1:** Reserved, maintain clear
- 2:** For borrow the polarity is reversed. A subtraction is executed by adding the two's complement of the second operand. For rotate (`RRF`, `RLF`) instructions, this bit is loaded with either the high or low order bit of the source register.

#### Legend:

R = Readable bit	W = Writable bit	U = Unimplemented bit, read as '0'
-n = Value at POR	'1' = Bit is set	'0' = Bit is cleared    x = Bit is unknown

# PIC16F716

## 2.2.2.2 OPTION\_REG Register

The OPTION\_REG register is a readable and writable register, which contains various control bits to configure the TMR0 prescaler/WDT postscaler (single assignable register known also as the prescaler), the External INT Interrupt, TMR0 and the weak pull-ups on PORTB.

**Note:** To achieve a 1:1 prescaler assignment for the TMR0 register, assign the prescaler to the Watchdog Timer.

### REGISTER 2-2: OPTION\_REG REGISTER (ADDRESS: 81h)

	R/W-1	R/W-1	R/W-1	R/W-1	R/W-1	R/W-1	R/W-1	R/W-1
	$\overline{\text{RBPU}}$	INTEDG	T0CS	T0SE	PSA	PS2	PS1	PS0
bit 7								bit 0

- bit 7 **RBPU:** PORTB Weak Pull-up Enable bit  
1 = PORTB weak pull-ups are disabled  
0 = PORTB weak pull-ups are determined by alternate function or TRISBn bit value
- bit 6 **INTEDG:** Interrupt Edge Select bit  
1 = Interrupt on rising edge of RB0/INT pin  
0 = Interrupt on falling edge of RB0/INT pin
- bit 5 **T0CS:** TMR0 Clock Source Select bit  
1 = Transition on RA4/T0CKI pin  
0 = Internal instruction cycle clock (CLKOUT)
- bit 4 **T0SE:** TMR0 Source Edge Select bit  
1 = Increment on high-to-low transition on RA4/T0CKI pin  
0 = Increment on low-to-high transition on RA4/T0CKI pin
- bit 3 **PSA:** Prescaler Assignment bit  
1 = Prescaler is assigned to the WDT  
0 = Prescaler is assigned to the Timer0 module
- bit 2-0 **PS2:PS0:** Prescaler Rate Select bits

Bit Value	TMR0 Rate	WDT Rate
000	1 : 2	1 : 1
001	1 : 4	1 : 2
010	1 : 8	1 : 4
011	1 : 16	1 : 8
100	1 : 32	1 : 16
101	1 : 64	1 : 32
110	1 : 128	1 : 64
111	1 : 256	1 : 128

**Legend:**  
 R = Readable bit                      W = Writable bit                      U = Unimplemented bit, read as '0'  
 -n = Value at POR                      '1' = Bit is set                      '0' = Bit is cleared                      x = Bit is unknown

## 2.2.2.3 INTCON Register

The INTCON Register is a readable and writable register which contains various enable and flag bits for the TMR0 register overflow, RB Port change and external RB0/INT pin interrupts.

**Note:** Interrupt flag bits get set when an interrupt condition occurs, regardless of the state of its corresponding enable bit or the global enable bit, GIE (INTCON<7>). User software should ensure the appropriate interrupt flag bits are clear prior to enabling an interrupt.

### REGISTER 2-3: INTCON REGISTER (ADDRESS: 0Bh, 8Bh)

R/W-0	R/W-0	R/W-0	R/W-0	R/W-0	R/W-0	R/W-0	R/W-x
GIE	PEIE	TOIE	INTE	RBIE	TOIF	INTF	RBIF
							bit 0
							bit 7

- bit 7 **GIE:** Global Interrupt Enable bit  
1 = Enables all un-masked interrupts  
0 = Disables all interrupts
- bit 6 **PEIE:** Peripheral Interrupt Enable bit  
1 = Enables all un-masked peripheral interrupts  
0 = Disables all peripheral interrupts
- bit 5 **TOIE:** TMR0 Overflow Interrupt Enable bit  
1 = Enables the TMR0 interrupt  
0 = Disables the TMR0 interrupt
- bit 4 **INTE:** RB0/INT External Interrupt Enable bit  
1 = Enables the RB0/INT external interrupt  
0 = Disables the RB0/INT external interrupt
- bit 3 **RBIE:** RB Port Change Interrupt Enable bit  
1 = Enables the RB port change interrupt  
0 = Disables the RB port change interrupt
- bit 2 **TOIF:** TMR0 Overflow Interrupt Flag bit  
1 = TMR0 register has overflowed (must be cleared in software)  
0 = TMR0 register did not overflow
- bit 1 **INTF:** RB0/INT External Interrupt Flag bit  
1 = The RB0/INT external interrupt occurred (must be cleared in software)  
0 = The RB0/INT external interrupt did not occur
- bit 0 **RBIF:** RB Port Change Interrupt Flag bit  
1 = At least one of the RB7:RB4 pins changed state (must be cleared in software)  
0 = None of the RB7:RB4 pins have changed state

**Legend:**

R = Readable bit	W = Writable bit	U = Unimplemented bit, read as '0'
-n = Value at POR	'1' = Bit is set	'0' = Bit is cleared    x = Bit is unknown

# PIC16F716

## 2.2.2.4 PIE1 Register

This register contains the individual enable bits for the peripheral interrupts.

**Note:** Bit PEIE (INTCON<6>) must be set to enable any peripheral interrupt.

### REGISTER 2-4: PIE1 REGISTER (ADDRESS: 8Ch)

	U-0	R/W-0	U-0	U-0	U-0	R/W-0	R/W-0	R/W-0
	—	ADIE	—	—	—	CCP1IE	TMR2IE	TMR1IE
bit 7								bit 0

- bit 7     **Unimplemented:** Read as '0'
- bit 6     **ADIE:** A/D Converter Interrupt Enable bit  
           1 = Enables the A/D interrupt  
           0 = Disables the A/D interrupt
- bit 5-3   **Unimplemented:** Read as '0'
- bit 2     **CCP1IE:** CCP1 Interrupt Enable bit  
           1 = Enables the CCP1 interrupt  
           0 = Disables the CCP1 interrupt
- bit 1     **TMR2IE:** TMR2 to PR2 Match Interrupt Enable bit  
           1 = Enables the TMR2 to PR2 match interrupt  
           0 = Disables the TMR2 to PR2 match interrupt
- bit 0     **TMR1IE:** TMR1 Overflow Interrupt Enable bit  
           1 = Enables the TMR1 overflow interrupt  
           0 = Disables the TMR1 overflow interrupt

**Legend:**

R = Readable bit	W = Writable bit	U = Unimplemented bit, read as '0'
-n = Value at POR	'1' = Bit is set	'0' = Bit is cleared    x = Bit is unknown



## 2.2.2.5 PIR1 Register

This register contains the individual flag bits for the peripheral interrupts.

**Note:** Interrupt flag bits get set when an interrupt condition occurs, regardless of the state of its corresponding enable bit or the global enable bit, GIE (INTCON<7>). User software should ensure the appropriate interrupt flag bits are clear prior to enabling an interrupt.

### REGISTER 2-5: PIR1 REGISTER (ADDRESS: 0Ch)

U-0	R/W-0	U-0	U-0	U-0	R/W-0	R/W-0	R/W-0
—	ADIF	—	—	—	CCP1IF	TMR2IF	TMR1IF
bit 7				bit 0			

- bit 7      **Unimplemented:** Read as '0'
- bit 6      **ADIF:** A/D Converter Interrupt Flag bit  
1 = An A/D conversion completed (must be cleared in software)  
0 = The A/D conversion is not complete
- bit 5-3    **Unimplemented:** Read as '0'
- bit 2      **CCP1IF:** CCP1 Interrupt Flag bit  
Capture Mode  
1 = A TMR1 register capture occurred (must be cleared in software)  
0 = No TMR1 register capture occurred  
Compare Mode  
1 = A TMR1 register compare match occurred (must be cleared in software)  
0 = No TMR1 register compare match occurred  
PWM Mode  
Unused in this mode
- bit 1      **TMR2IF:** TMR2 to PR2 Match Interrupt Flag bit  
1 = TMR2 to PR2 match occurred (must be cleared in software)  
0 = No TMR2 to PR2 match occurred
- bit 0      **TMR1IF:** TMR1 Overflow Interrupt Flag bit  
1 = TMR1 register overflowed (must be cleared in software)  
0 = TMR1 register did not overflow

**Legend:**

R = Readable bit	W = Writable bit	U = Unimplemented bit, read as '0'
-n = Value at POR	'1' = Bit is set	'0' = Bit is cleared      x = Bit is unknown

# PIC16F716

## 2.2.2.6 PCON Register

The Power Control (PCON) register contains a flag bit to allow differentiation between a Power-on Reset (POR) to an external MCLR Reset or WDT Reset. These devices contain an additional bit to differentiate a Brown-out Reset condition from a Power-on Reset condition.

**Note:** If the BOREN configuration bit is set,  $\overline{\text{BOR}}$  is '1' on Power-on Reset and reset to '0' when a Brown-out condition occurs.  $\overline{\text{BOR}}$  must then be set by the user and checked on subsequent resets to see if it is clear, indicating that another Brown-out has occurred.

If the BOREN configuration bit is clear,  $\overline{\text{BOR}}$  is unknown on Power-on Reset.

### REGISTER 2-6: PCON REGISTER (ADDRESS: 8Eh)

	U-0	U-0	U-0	U-0	U-0	U-0	R/W-0	R/W-q
	—	—	—	—	—	—	$\overline{\text{POR}}$	$\overline{\text{BOR}}$
bit 7							bit 0	

- bit 7-2     **Unimplemented:** Read as '0'
- bit 1     **POR:** Power-on Reset Status bit  
           1 = No Power-on Reset occurred  
           0 = A Power-on Reset occurred (must be set in software after a Power-on Reset occurs)
- bit 0     **BOR:** Brown-out Reset Status bit  
           1 = No Brown-out Reset occurred  
           0 = A Brown-out Reset occurred (must be set in software after a Brown-out Reset occurs)

<b>Legend:</b>		q = Depends on condition
R = Readable bit	W = Writable bit	U = Unimplemented bit, read as '0'
-n = Value at POR	'1' = Bit is set	'0' = Bit is cleared     x = Bit is unknown

## 2.3 PCL and PCLATH

The Program Counter (PC) specifies the address of the instruction to fetch for execution. The PC is 13 bits wide. The low byte is called the PCL register. This register is readable and writable. The high byte is called the PCH register. This register contains the PC<12:8> bits and is not directly readable or writable. All updates to the PCH register go through the PCLATH register.

### 2.3.1 MODIFYING PCL

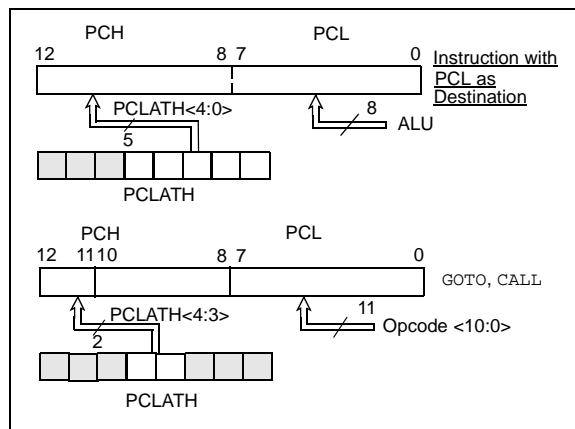
Executing any instruction with the PCL register as the destination simultaneously causes the Program Counter PC<12:8> bits (PCH) to be replaced by the contents of PCLATH register. This allows the entire contents of the program counter to be changed by first writing the desired upper 5 bits to the PCLATH register. When the lower 8 bits are then written to the PCL register, all 13 bits of the program counter will change to the values contained in the PCLATH register and those being written to the PCL register.

Care should be exercised when modifying the PCL register to jump into a look-up table or program branch table (computed GOTO). With PCLATH set to the table start address, if the table is greater than 255 instructions or if the lower 8 bits of the memory address rolls over from 0xFF to 0x00 in the middle of the table, then PCLATH must be incremented for each address rollover that occurs between the table beginning and the target address.

### 2.3.2 PROGRAM MEMORY PAGING

The CALL and GOTO instructions provide 11 bits of address to allow branching within any 2K program memory page. When doing a CALL or GOTO instruction, the upper bit of the address is provided by PCLATH<3>. When doing a CALL or GOTO instruction, the user must ensure that the page select bit is programmed so that the desired program memory page is addressed. If a RETURN from a CALL instruction (or interrupt) is executed, the entire 13-bit PC is pushed onto the stack. Therefore, manipulation of the PCLATH<3> bit is not required for the RETURN instructions (which POPs the address from the stack).

**FIGURE 2-3: LOADING OF PC IN DIFFERENT SITUATIONS**



## 2.4 Stack

The stack allows a combination of up to 8 program calls and interrupts to occur. The stack contains the return address from this branch in program execution.

Mid-range devices have an 8-level deep x 13-bit wide hardware stack. The stack space is not part of either program or data space, and the stack pointer is not readable or writable. The PC is PUSHed onto the stack when a CALL instruction is executed or an interrupt causes a branch. The stack is POPed in the event of a RETURN, RETLW or a RETFIE instruction execution. PCLATH is not modified when the stack is PUSHed or POPed.

After the stack has been PUSHed 8 times, the ninth push overwrites the value that was stored from the first push. The tenth push overwrites the second push (and so on).

# PIC16F716

## 2.5 Indirect Addressing, INDF and FSR Registers

The INDF register is not a physical register. Addressing INDF actually addresses the register whose address is contained in the FSR register (FSR is a *pointer*). This is indirect addressing.

### EXAMPLE 2-1: INDIRECT ADDRESSING

- Register file 05 contains the value 10h
- Register file 06 contains the value 0Ah
- Load the value 05 into the FSR register
- A read of the INDF register will return the value of 10h
- Increment the value of the FSR register by one (FSR = 06)
- A read of the INDF register now will return the value of 0Ah.

Reading INDF itself indirectly (FSR = 0) will produce 00h. Writing to the INDF register indirectly results in a no-operation (although Status bits may be affected).

A simple program to clear RAM locations 20h – 2Fh using indirect addressing is shown in Example 2-2.

### EXAMPLE 2-2: HOW TO CLEAR RAM USING INDIRECT ADDRESSING

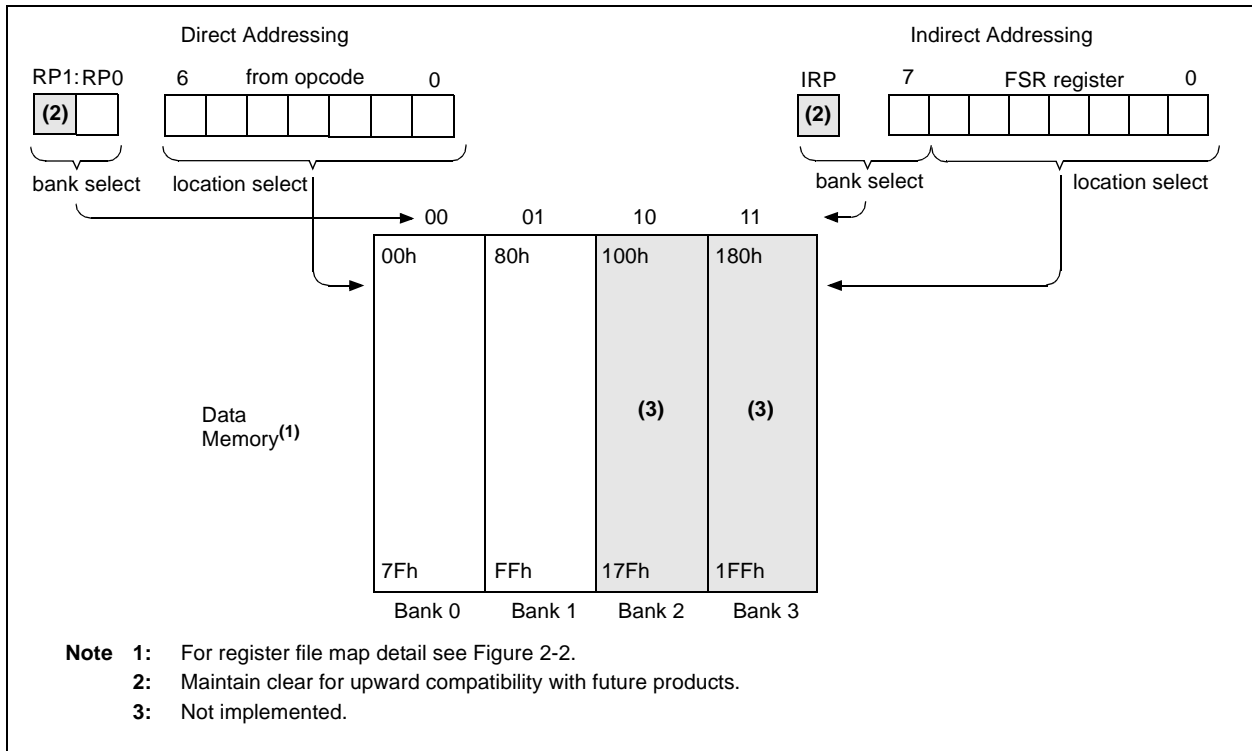
```

MOV LW 0x20 ;initialize pointer
MOV WF FSR ;to RAM
NEXT   CLRF INDF ;clear RAM & FSR
       INC FSR ;inc pointer
       BTFSS FSR,4 ;all done?
       GOTO NEXT ;no, clear next

CONTINUE
      : ;yes, continue
    
```

An effective 9-bit address is obtained by concatenating the 8-bit FSR register and the IRP bit (STATUS<7>), as shown in Figure 2-4. However, IRP is not used in the PIC16F716.

FIGURE 2-4: DIRECT/INDIRECT ADDRESSING



## 3.0 I/O PORTS

Some pins for these I/O ports are multiplexed with an alternate function for the peripheral features on the device. In general, when a peripheral is enabled, that pin may not be used as a general purpose I/O pin.

Additional information on I/O ports may be found in the PICmicro® Mid-Range Reference Manual, (DS33023).

### 3.1 PORTA and the TRISA Register

PORTA is a 5-bit wide bidirectional port. The corresponding data direction register is TRISA. Setting a TRISA bit (= 1) will make the corresponding PORTA pin an input (i.e., put the corresponding output driver in a High-impedance mode). Clearing a TRISA bit (= 0) will make the corresponding PORTA pin an output (i.e., put the contents of the output latch on the selected pin).

Reading the PORTA register reads the status of the pins, whereas writing to it will write to the port latch. All write operations are read-modify-write operations. Therefore, a write to a port implies that the port pins are read, the value is modified and then written to the port data latch.

Pin RA4 is multiplexed with the Timer0 module clock input to become the RA4/T0CKI pin. The RA4/T0CKI pin is a Schmitt Trigger input and an open drain output. All other RA port pins have TTL input levels and full CMOS output drivers.

PORTA pins, RA3:0, are multiplexed with analog inputs and analog VREF input. The operation of each pin is selected by clearing/setting the control bits in the ADCON1 register (A/D Control Register 1).

**Note:** On a Power-on Reset, these pins are configured as analog inputs and read as '0'.

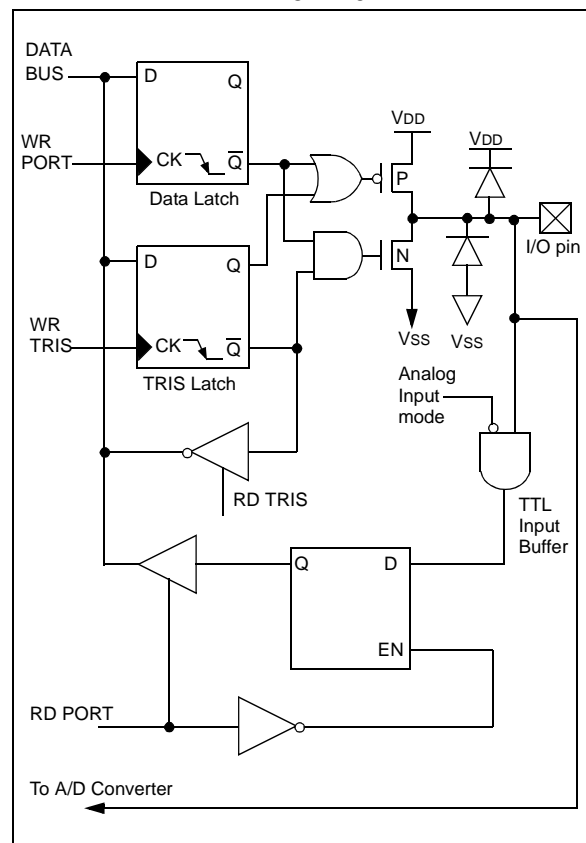
The TRISA register controls the direction of the RA pins, even when they are being used as analog inputs. The user must ensure the bits in the TRISA register are maintained set when using them as analog inputs.

**Note:** Setting RA3:0 to output while in Analog mode will force pins to output contents of data latch.

### EXAMPLE 3-1: INITIALIZING PORTA

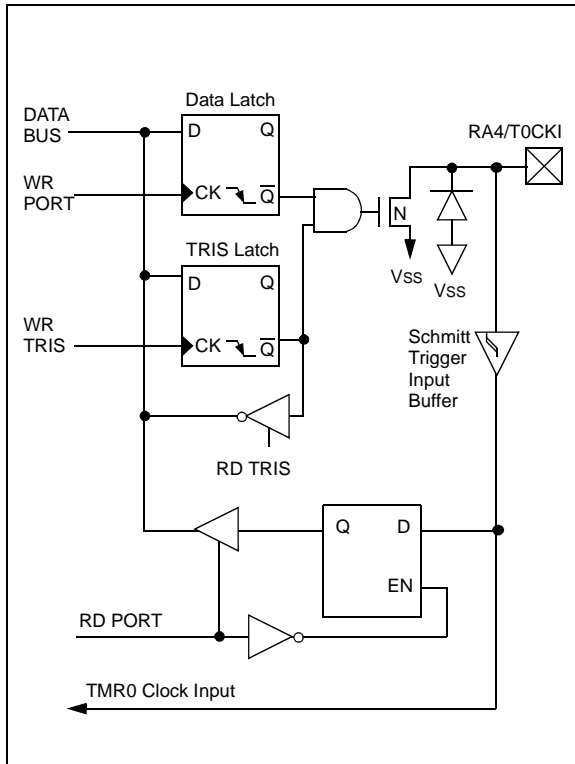
```
BCF STATUS, RP0 ;
CLRF PORTA      ;Initialize PORTA by
                ;clearing output
                ;data latches
BSF STATUS, RP0 ;Select Bank 1
MOVLW 0xEF      ;Value used to
                ;initialize data
                ;direction
MOVWF TRISA     ;Set RA<3:0> as inputs
                ;RA<4> as outputs
BCF STATUS, RP0 ;Return to Bank 0
```

**FIGURE 3-1: BLOCK DIAGRAM OF RA3:RA0**



# PIC16F716

**FIGURE 3-2: BLOCK DIAGRAM OF RA4/T0CKI PIN**



**TABLE 3-1: PORTA FUNCTIONS**

Name	Bit#	Buffer	Function
RA0/AN0	bit 0	TTL	Input/output or analog input
RA1/AN1	bit 1	TTL	Input/output or analog input
RA2/AN2	bit 2	TTL	Input/output or analog input
RA3/AN3/VREF	bit 3	TTL	Input/output or analog input or VREF
RA4/T0CKI	bit 4	ST	Input/output or external clock input for Timer0 Output is open drain type

**Legend:** TTL = TTL input, ST = Schmitt Trigger input

**TABLE 3-2: SUMMARY OF REGISTERS ASSOCIATED WITH PORTA**

Address	Name	Bit 7	Bit 6	Bit 5	Bit 4	Bit 3	Bit 2	Bit 1	Bit 0	Value on POR, BOR	Value on all other Resets
05h	PORTA	—	—	— <sup>(1)</sup>	RA4	RA3	RA2	RA1	RA0	--xx 0000	--uu uuuu
85h	TRISA	—	—	— <sup>(1)</sup>	PORTA Data Direction Register					--11 1111	--11 1111
9Fh	ADCON1	—	—	—	—	—	PCFG2	PCFG1	PCFG0	---- -000	---- -000

**Legend:** x = unknown, u = unchanged, - = unimplemented locations read as '0'. Shaded cells are not used by PORTA.

**Note 1:** Reserved bits, do not use.

## 3.2 PORTB and the TRISB Register

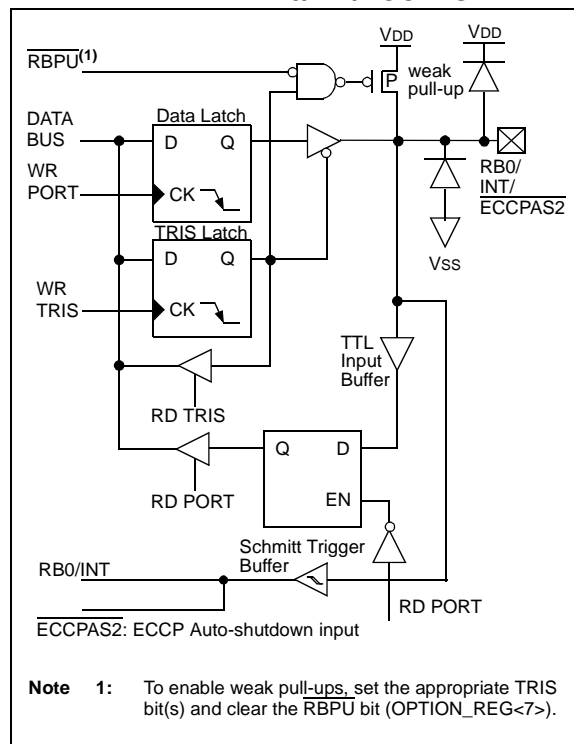
PORTB is an 8-bit wide bidirectional port. The corresponding data direction register is TRISB. Setting a TRISB bit (= 1) will make the corresponding PORTB pin an input (i.e., put the corresponding output driver in a High-impedance mode). Clearing a TRISB bit (= 0) will make the corresponding PORTB pin an output (i.e., put the contents of the output latch on the selected pin).

### EXAMPLE 3-2: INITIALIZING PORTB

```
BCF    STATUS, RP0    ;select Bank 0
CLRF   PORTB         ;Initialize PORTB by
                    ;clearing output
                    ;data latches
BSF    STATUS, RP0    ;Select Bank 1
MOVLW  0xCF          ;Value used to
                    ;initialize data
                    ;direction
MOVWF  TRISB         ;Set RB<3:0> as inputs
                    ;RB<5:4> as outputs
                    ;RB<7:6> as inputs
```

Each of the PORTB pins has a weak internal pull-up. A single control bit can turn on all the pull-ups. This is performed by clearing bit  $\overline{\text{RBPU}}$  (OPTION\_REG<7>). The weak pull-up is automatically turned off when the port pin is configured as an output. The pull-ups are disabled on a Power-on Reset.

**FIGURE 3-3: BLOCK DIAGRAM OF RB0/INT/ECCPAS2 PIN**



PORTB pins RB7:RB0 are multiplexed with several peripheral functions (Table 3-3).

When enabling peripheral functions, care should be taken in defining TRIS bits for each PORTB pin. Some peripherals override the TRIS bit to make a pin an output, while other peripherals override the TRIS bit to make a pin an input. Since the TRIS bit override is in effect while the peripheral is enabled, read-modify-write instructions (such as BSF, BCF, XORWF) with TRISB as the destination should be avoided. The user should refer to the corresponding peripheral section for the correct TRIS bit settings.

Four of PORTB's pins, RB7:RB4, have an interrupt-on-change feature. Only pins configured as inputs can cause this interrupt to occur (i.e., any RB7:RB4 pin configured as an output is excluded from the interrupt-on-change comparison). The input pins, RB7:RB4, are compared with the old value latched on the last read of PORTB. The "mismatch" outputs of RB7:RB4 are OR'ed together to generate the RB Port Change Interrupt with flag bit RBIF (INTCON<0>).

This interrupt can wake the device from Sleep. The user, in the interrupt service routine, can clear the interrupt in the following manner:

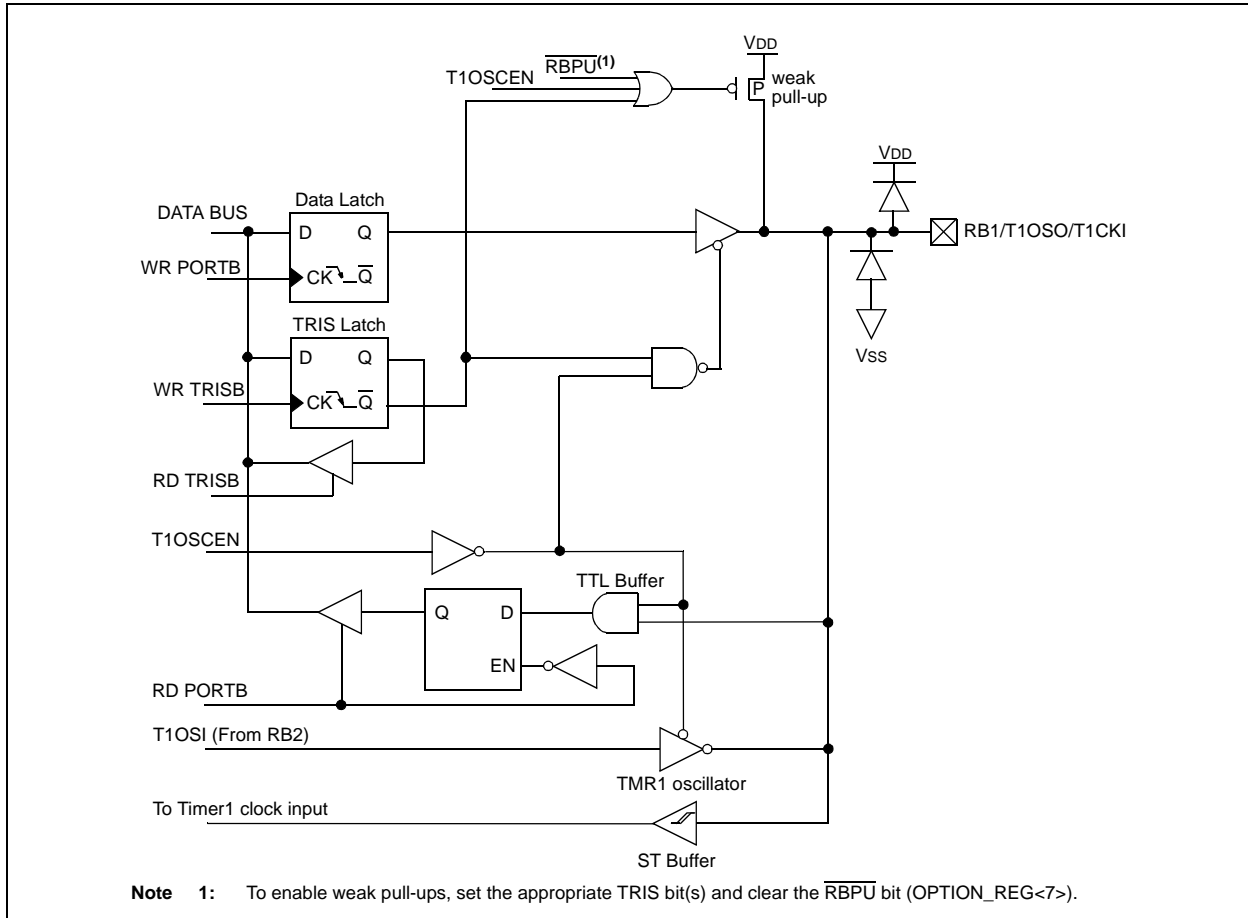
1. Perform a read of PORTB to end the mismatch condition.
2. Clear flag bit RBIF.

A mismatch condition will continue to set flag bit RBIF. Reading PORTB will end the mismatch condition and allow flag bit RBIF to be cleared.

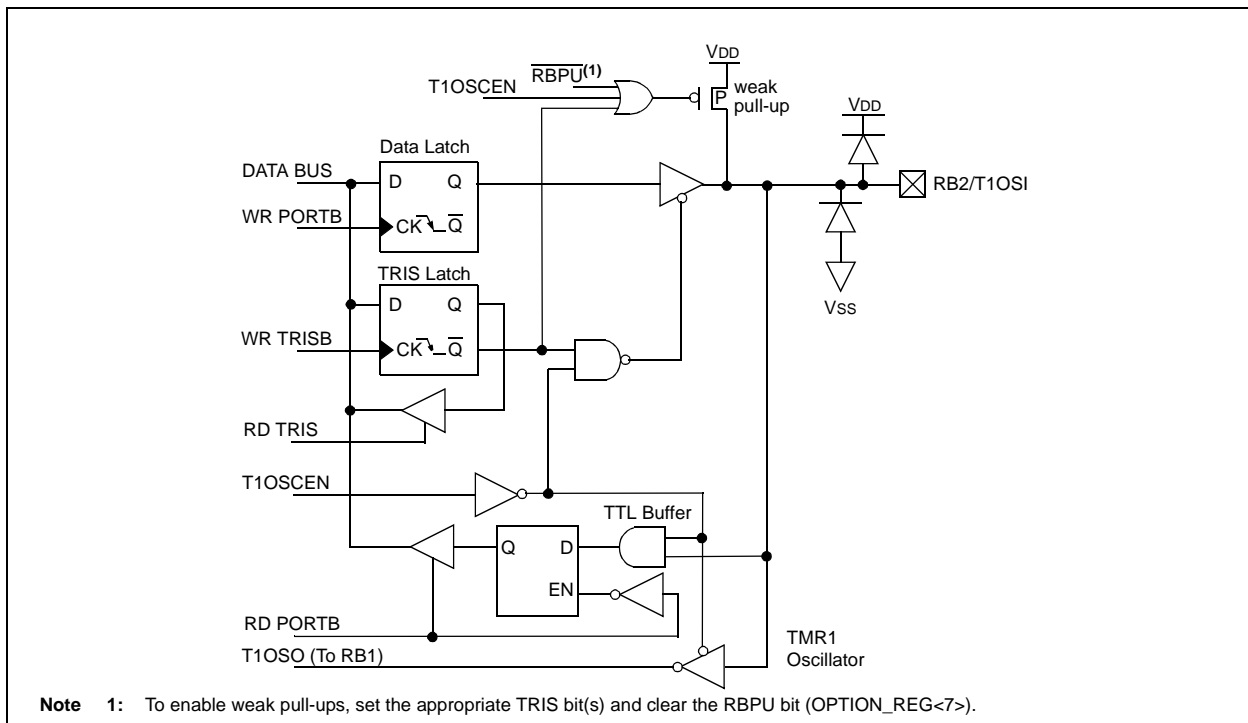
The interrupt-on-change feature is recommended for wake-up on key depression operation and operations where PORTB is only used for the interrupt-on-change feature. Polling of PORTB is not recommended while using the interrupt-on-change feature.

# PIC16F716

**FIGURE 3-4: BLOCK DIAGRAM OF RB1/T1OSO/T1CKI PIN**

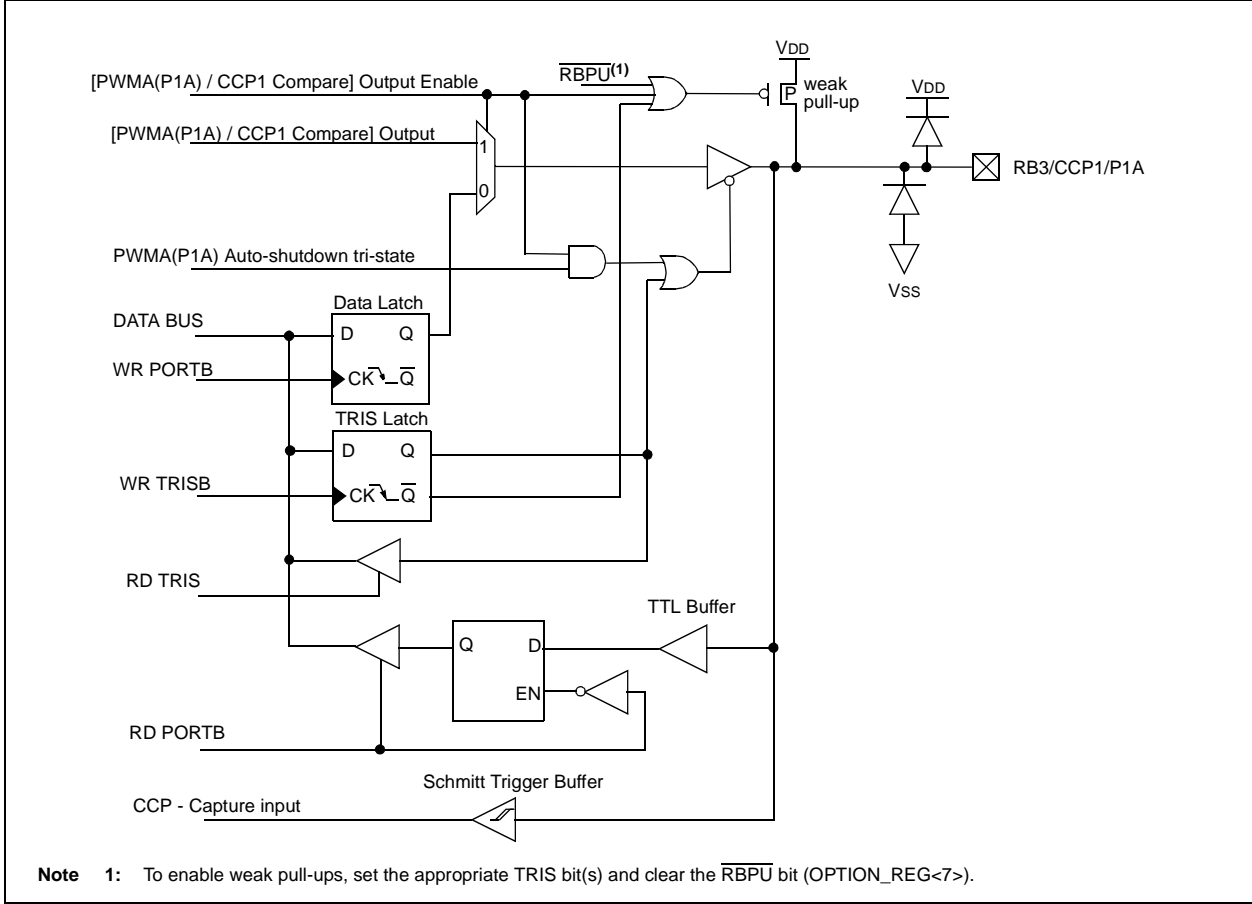


**FIGURE 3-5: BLOCK DIAGRAM OF RB2/T1OSI PIN**

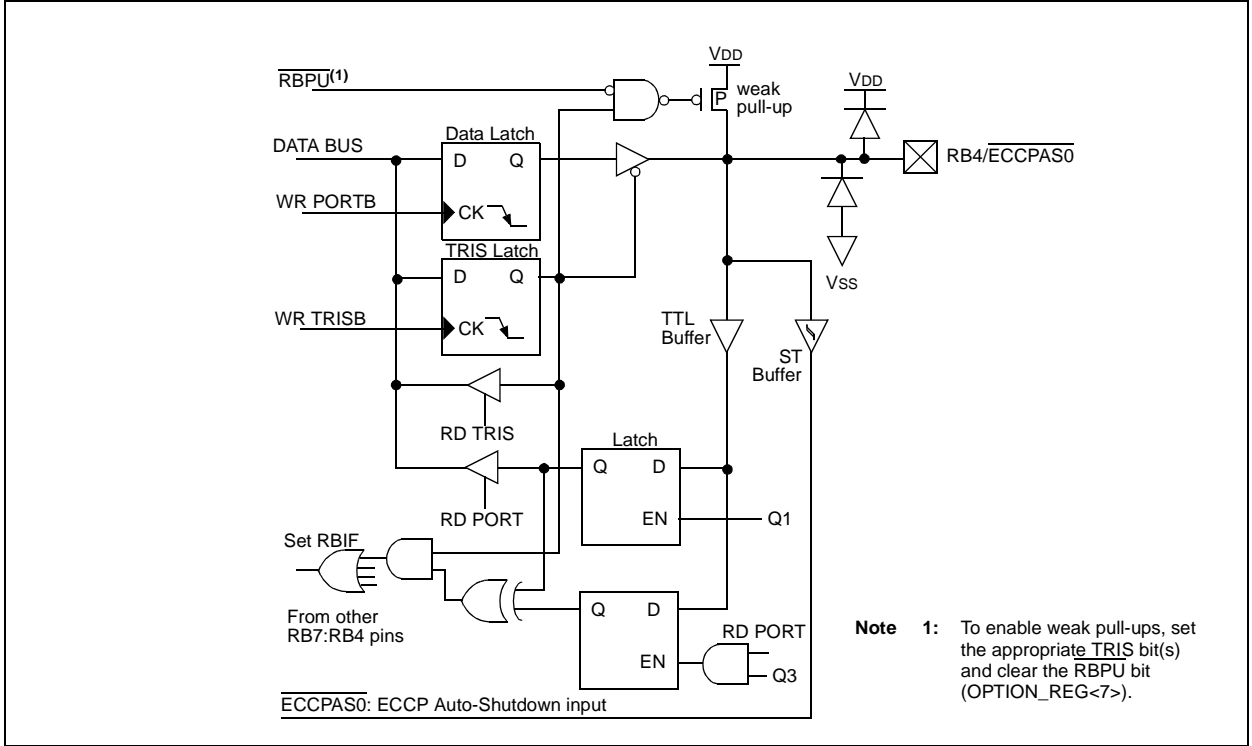




**FIGURE 3-6: BLOCK DIAGRAM OF RB3/CCP1/P1A PIN**

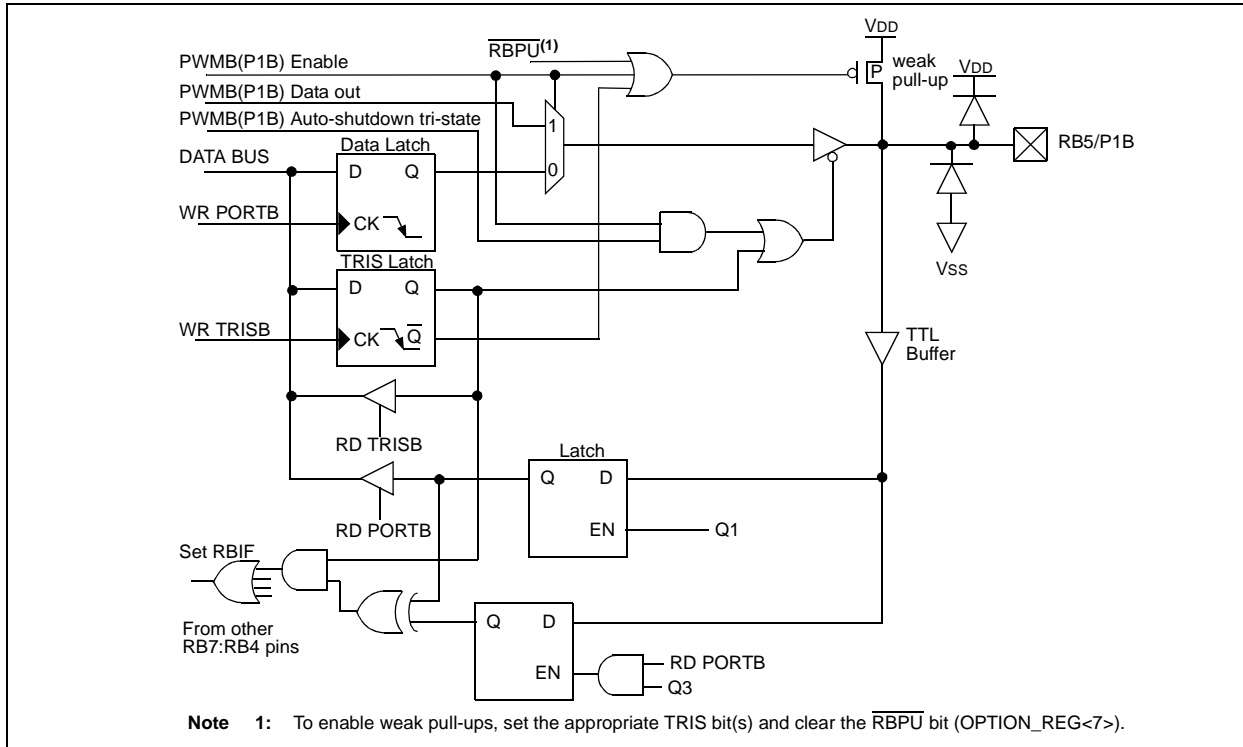


**FIGURE 3-7: BLOCK DIAGRAM OF RB4/ECCPAS0 PIN**

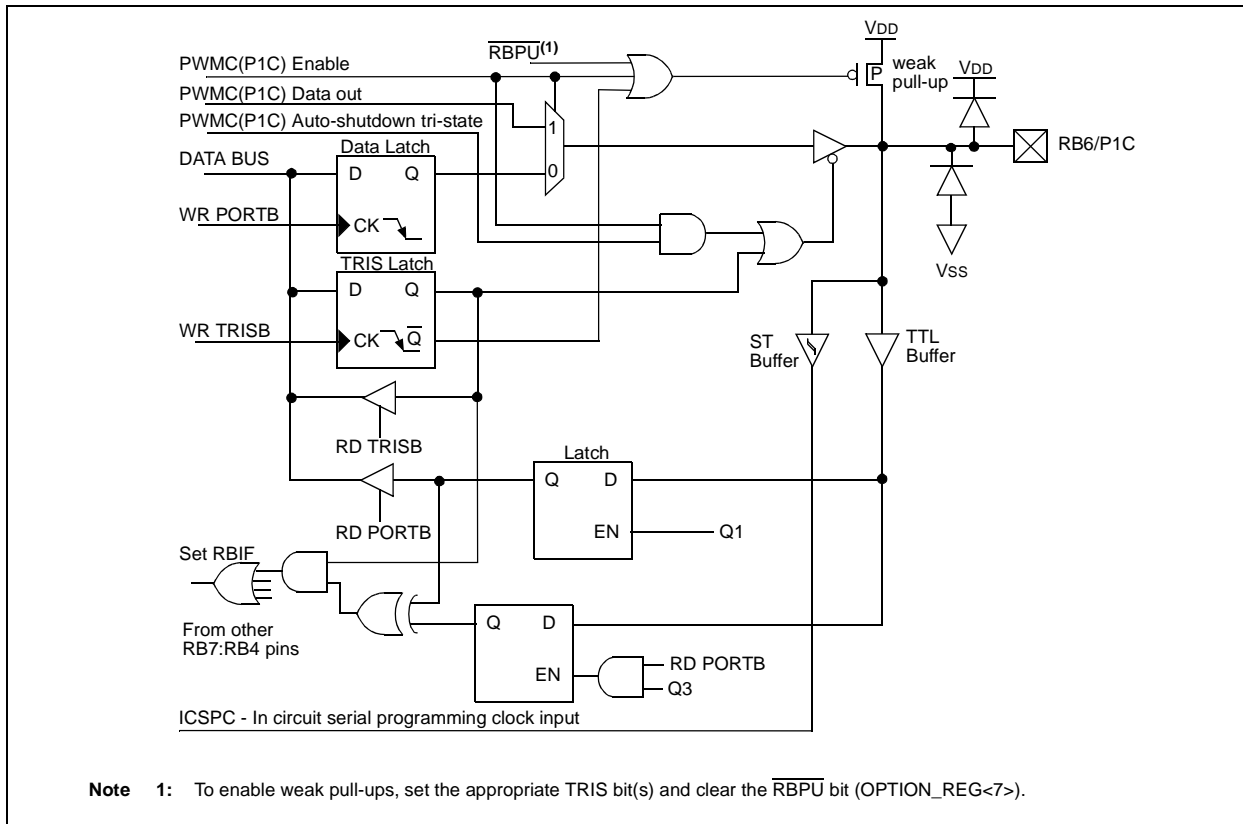


# PIC16F716

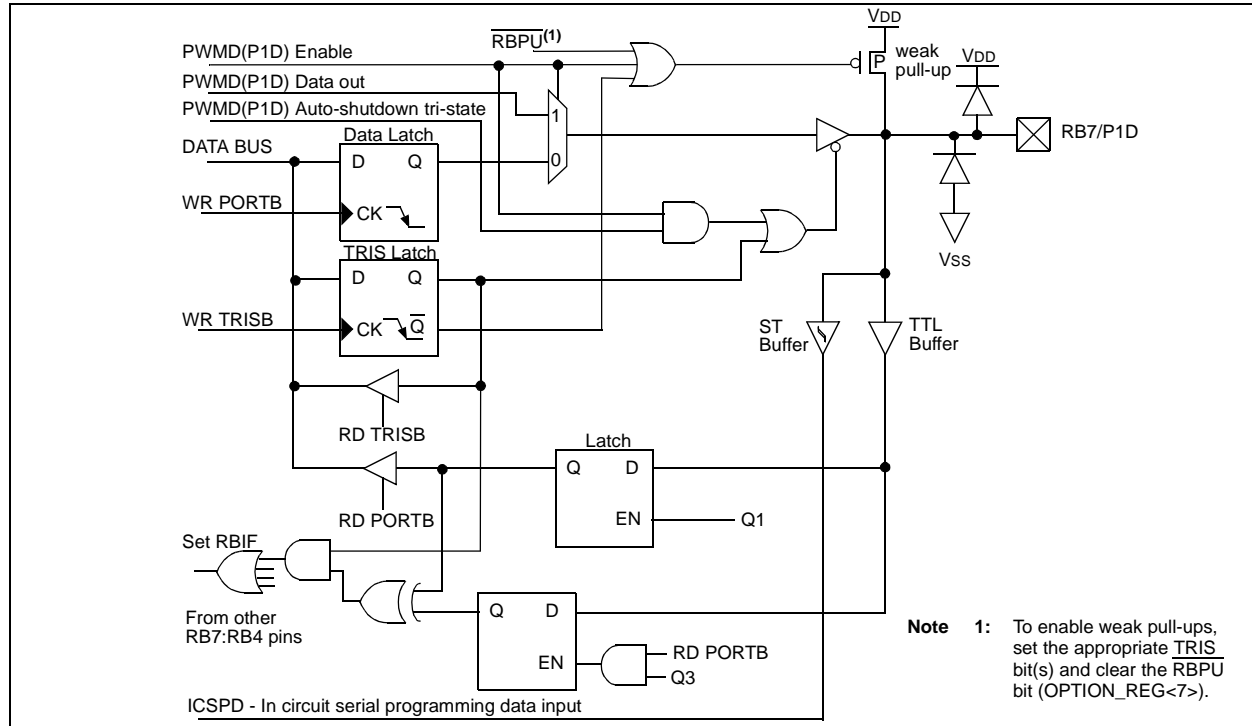
**FIGURE 3-8: BLOCK DIAGRAM OF RB5/P1B PIN**



**FIGURE 3-9: BLOCK DIAGRAM OF RB6/P1C PIN**



**FIGURE 3-10: BLOCK DIAGRAM OF RB7/P1D PIN**



**TABLE 3-3: PORTB FUNCTIONS**

Name	Bit#	Buffer	Function
RB0/INT/ ECCPAS2	bit 0	TTL/ST <sup>(1)</sup>	Input/output pin or external interrupt input. Internal software programmable weak pull-up. ECCP auto-shutdown input.
RB1/T1OS0/ T1CKI	bit 1	TTL/ST <sup>(1)</sup>	Input/output pin or Timer1 oscillator output, or Timer1 clock input. Internal software programmable weak pull-up. See <b>Section 5.0 “Timer1 Module”</b> for detailed operation.
RB2/T1OSI	bit 2	TTL/XTAL	Input/output pin or Timer1 oscillator input. Internal software programmable weak pull-up. See <b>Section 5.0 “Timer1 Module”</b> for detailed operation.
RB3/CCP1/ P1A	bit 3	TTL/ST <sup>(1)</sup>	Input/output pin or Capture1 input, or Compare1 output, or PWM A output. Internal software programmable weak pull-up. See CCP1 section for detailed operation.
RB4/ ECCPAS0	bit 4	TTL	Input/output pin (with interrupt-on-change). Internal software programmable weak pull-up. ECCP auto-shutdown input.
RB5/P1B	bit 5	TTL	Input/output pin (with interrupt-on-change). Internal software programmable weak pull-up. PWM B output.
RB6/P1C	bit 6	TTL/ST <sup>(2)</sup>	Input/output pin (with interrupt-on-change). Internal software programmable weak pull-up. PWM C output. Serial programming clock.
RB7/P1D	bit 7	TTL/ST <sup>(2)</sup>	Input/output pin (with interrupt-on-change). Internal software programmable weak pull-up. PWM D output. Serial programming data.

**Legend:** TTL = TTL input, ST = Schmitt Trigger input, XTAL = Crystal Oscillator input

**Note 1:** This buffer is a Schmitt Trigger input when configured as the external interrupt or peripheral input.

**2:** This buffer is a Schmitt Trigger input when used in Serial Programming mode.

# PIC16F716

**TABLE 3-4: SUMMARY OF REGISTERS ASSOCIATED WITH PORTB**

Address	Name	Bit 7	Bit 6	Bit 5	Bit 4	Bit 3	Bit 2	Bit 1	Bit 0	Value on: POR, BOR	Value on all other Resets
06h	PORTB	RB7	RB6	RB5	RB4	RB3	RB2	RB1	RB0	xxxx xxxx	uuuu uuuu
86h	TRISB	PORTB Data Direction Register								1111 1111	1111 1111
81h	OPTION_REG	$\overline{\text{RBPU}}$	INTEDG	T0CS	T0SE	PSA	PS2	PS1	PS0	1111 1111	1111 1111

**Legend:** x = unknown, u = unchanged. Shaded cells are not used by PORTB.

## 4.0 TIMER0 MODULE

The Timer0 module timer/counter has the following features:

- 8-bit timer/counter
- Readable and writable
- Internal or external clock select
- Edge select for external clock
- 8-bit software programmable prescaler
- Interrupt on overflow from FFh to 00h

Figure 4-1 is a simplified block diagram of the Timer0 module.

Additional information on timer modules is available in the PICmicro® Mid-Range Reference Manual, (DS33023).

### 4.1 Timer0 Operation

Timer0 can operate as a timer or as a counter.

Timer mode is selected by clearing bit TOCS (OPTION\_REG<5>). In Timer mode, the Timer0 module will increment every instruction cycle (without prescaler). If the TMR0 register is written, the increment is inhibited for the following two instruction cycles. The user can work around this by writing an adjusted value to the TMR0 register.

Counter mode is selected by setting bit TOCS (OPTION\_REG<5>). In Counter mode, Timer0 will increment on every rising or falling edge of pin RA4/TOCKI. The incrementing edge is determined by the Timer0 Source Edge Select bit TOSE (OPTION\_REG<4>). Clearing bit TOSE selects the rising edge. Restrictions on the external clock input are discussed below.

When an external clock input is used for Timer0, it must meet certain requirements. The requirements ensure the external clock can be synchronized with the internal phase clock (Tosc). Also, there is a delay in the actual incrementing of Timer0 after synchronization.

Additional information on external clock requirements is available in the PICmicro® Mid-Range Reference Manual, (DS33023).

### 4.2 Prescaler

An 8-bit counter is available as a prescaler for the Timer0 module or as a postscaler for the Watchdog Timer, respectively (Figure 4-2). For simplicity, this counter is being referred to as “prescaler” throughout this data sheet.

**Note:** There is only one prescaler available, which is mutually exclusively shared between the Timer0 module and Watchdog Timer. Thus, a prescaler assignment for the Timer0 module means that there is no prescaler for the Watchdog Timer and vice-versa.

The prescaler is not readable or writable.

The PSA and PS2:PS0 bits (OPTION\_REG<3:0>) determine the prescaler assignment and prescale ratio.

Clearing bit PSA will assign the prescaler to the Timer0 module. When the prescaler is assigned to the Timer0 module, prescale values of 1:2, 1:4, ..., 1:256 are selectable.

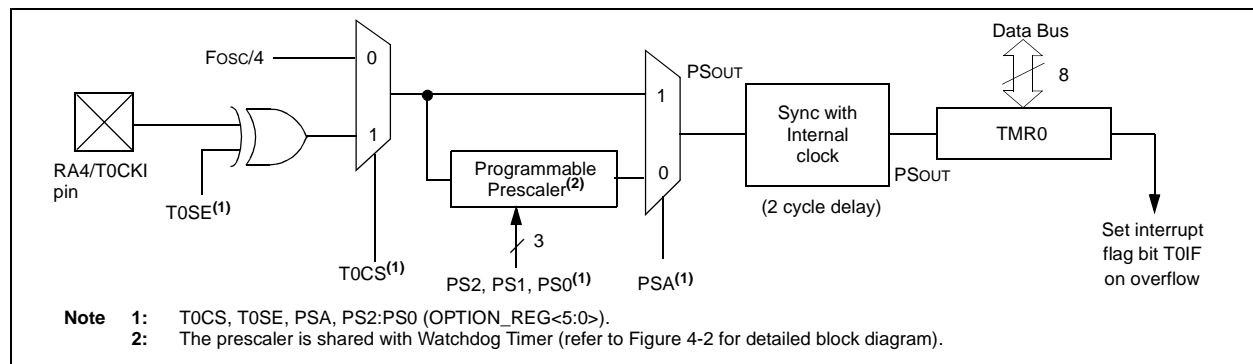
Setting bit PSA will assign the prescaler to the Watchdog Timer (WDT). When the prescaler is assigned to the WDT, prescale values of 1:1, 1:2, ..., 1:128 are selectable.

When assigned to the Timer0 module, all instructions writing to the TMR0 register (e.g. CLRF 1, MOVWF 1, BSF 1,x....etc.) will clear the prescaler. When assigned to WDT, a CLRWDT instruction will clear the prescaler along with the WDT.

**Note:** Writing to TMR0 when the prescaler is assigned to Timer0 will clear the prescaler count, but will not change the prescaler assignment.

**Note:** To achieve a 1:1 prescaler assignment for the TMR0 register, assign the prescaler to the Watchdog Timer.

**FIGURE 4-1: TIMER0 BLOCK DIAGRAM**



# PIC16F716

## 4.2.1 SWITCHING PRESCALER ASSIGNMENT

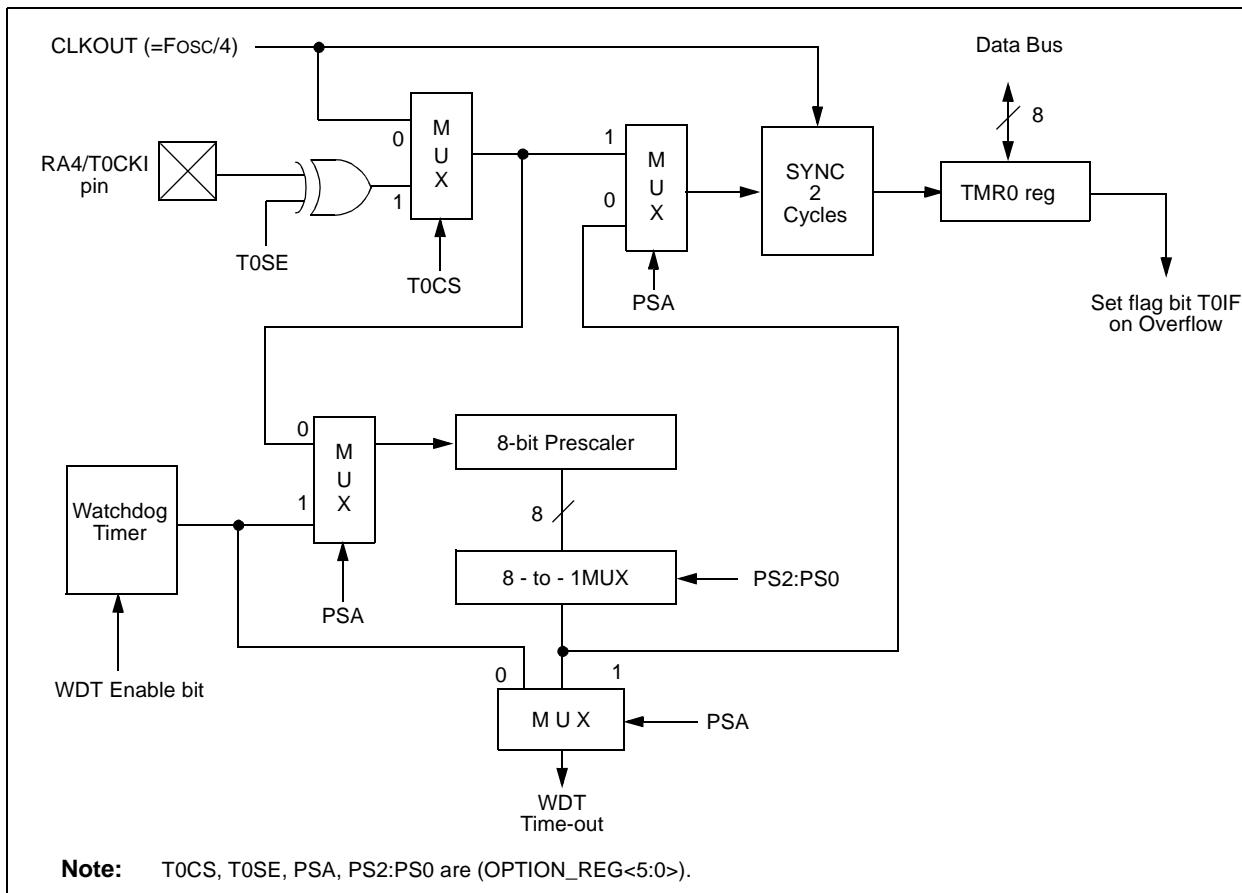
The prescaler assignment is fully under software control (i.e., it can be changed “on-the-fly” during program execution).

**Note:** To avoid an unintended device Reset, a specific instruction sequence (shown in the PICmicro® Mid-Range Reference Manual, DS33023) must be executed when changing the prescaler assignment from Timer0 to the WDT. This sequence must be followed even if the WDT is disabled.

## 4.3 Timer0 Interrupt

The TMR0 interrupt is generated when the TMR0 register overflows from FFh to 00h. This overflow sets bit TOIF (INTCON<2>). The interrupt can be masked by clearing bit TOIE (INTCON<5>). Bit TOIF must be cleared in software by the Timer0 module interrupt service routine before re-enabling this interrupt. The TMR0 interrupt cannot awaken the processor from Sleep since the timer is shut off during Sleep.

**FIGURE 4-2: BLOCK DIAGRAM OF THE TIMER0/WDT PRESCALER**



**TABLE 4-1: REGISTERS ASSOCIATED WITH TIMER0**

Address	Name	Bit 7	Bit 6	Bit 5	Bit 4	Bit 3	Bit 2	Bit 1	Bit 0	Value on: POR, BOR	Value on all other Resets
01h	TMR0	Timer0 module's register								xxxx xxxx	uuuu uuuu
0Bh,8Bh	INTCON	GIE	PEIE	TOIE	INTE	RBIE	TOIF	INTF	RBIF	0000 000x	0000 000u
81h	OPTION_REG	RBPU	INTEDG	T0CS	T0SE	PSA	PS2	PS1	PS0	1111 1111	1111 1111
85h	TRISA	—	—	— <sup>(1)</sup>	Bit 4	PORTA Data Direction Register			—11 1111	--11 1111	

**Legend:** x = unknown, u = unchanged, - = unimplemented locations read as '0'. Shaded cells are not used by Timer0.

**Note 1:** Reserved bits, do not use.

## 5.0 TIMER1 MODULE

The Timer1 module timer/counter has the following features:

- 16-bit timer/counter  
(Two 8-bit registers; TMR1H and TMR1L)
- Readable and writable (Both registers)
- Internal or external clock select
- Interrupt on overflow from FFFFh to 0000h
- Reset from ECCP module trigger

Timer1 has a control register, shown in Register 5-1. Timer1 can be enabled/disabled by setting/clearing control bit TMR1ON (T1CON<0>).

Figure 5-1 is a simplified block diagram of the Timer1 module.

Additional information on timer modules is available in the PICmicro<sup>®</sup> Mid-Range Reference Manual, (DS33023).

## 5.1 Timer1 Operation

Timer1 can operate in one of these modes:

- As a timer
- As a synchronous counter
- As an asynchronous counter

The operating mode is determined by the clock select bit, TMR1CS (T1CON<1>).

In Timer mode, Timer1 increments every instruction cycle. In Counter mode, it increments on every rising edge of the external clock input.

When the Timer1 oscillator is enabled (T1OSCEN is set), the RB2/T1OSI and RB1/T1OSO/T1CKI pins become inputs. That is, the TRISB<2:1> value is ignored.

Timer1 also has an internal "Reset input". This Reset can be generated by the ECCP module (**Section 7.0 "Enhanced Capture/Compare/PWM (ECCP) Module"**).

### REGISTER 5-1: T1CON: TIMER1 CONTROL REGISTER (ADDRESS: 10h)

U-0	U-0	R/W-0	R/W-0	R/W-0	R/W-0	R/W-0	R/W-0	
—	—	T1CKPS1	T1CKPS0	T1OSCEN	T1SYNC	TMR1CS	TMR1ON	
bit 7								bit 0

bit 7-6 **Unimplemented:** Read as '0'

bit 5-4 **T1CKPS1:T1CKPS0:** Timer1 Input Clock Prescale Select bits

- 11 = 1:8 Prescale value
- 10 = 1:4 Prescale value
- 01 = 1:2 Prescale value
- 00 = 1:1 Prescale value

bit 3 **T1OSCEN:** Timer1 Oscillator Enable Control bit

- 1 = Oscillator is enabled
- 0 = Oscillator is shut off<sup>(1)</sup>

bit 2 **T1SYNC:** Timer1 External Clock Input Synchronization Control bit

**TMR1CS = 1**

- 1 = Do not synchronize external clock input
- 0 = Synchronize external clock input

**TMR1CS = 0**

This bit is ignored. Timer1 uses the internal clock when TMR1CS = 0.

bit 1 **TMR1CS:** Timer1 Clock Source Select bit

- 1 = External clock from pin RB1/T1OSO/T1CKI (on the rising edge after the first falling edge)
- 0 = Internal clock (FOSC/4)

bit 0 **TMR1ON:** Timer1 On bit

- 1 = Enables Timer1
- 0 = Stops Timer1

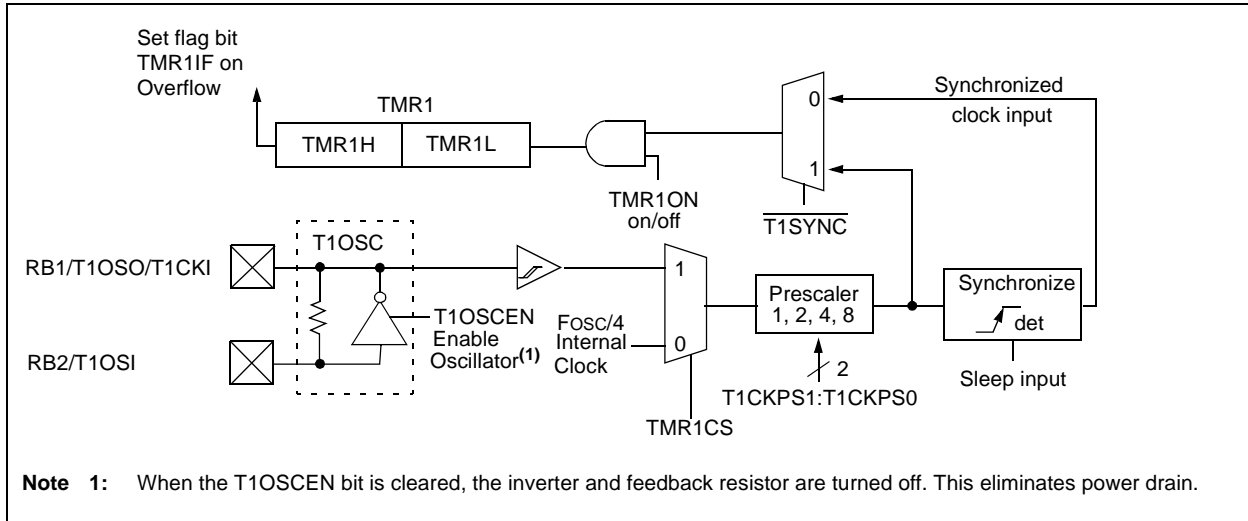
**Note 1:** The oscillator inverter and feedback resistor are turned off to eliminate power drain.

#### Legend:

R = Readable bit	W = Writable bit	U = Unimplemented bit, read as '0'
-n = Value at POR	'1' = Bit is set	'0' = Bit is cleared    x = Bit is unknown

# PIC16F716

**FIGURE 5-1: TIMER1 BLOCK DIAGRAM**



## 5.2 Timer1 Oscillator

A crystal oscillator circuit is built in between pins T1OSI (input) and T1OSO (amplifier output). It is enabled by setting control bit T1OSCEN (T1CON<3>). The oscillator is a low-power oscillator designed to operate with a 32.768 kHz tuning fork crystal. It will continue to run during Sleep.

The user must provide a software time delay to ensure proper oscillator start-up.

**Note 1:** Circuit guidelines for the LP oscillator (32 kHz), as shown in **Section 9.2 “Oscillator Configurations”**, also apply to the Timer1 Oscillator.

**2:** The Timer1 register pair, TMR1H and TMR1L, in combination with the Timer1 overflow flag (TMR1IF) can be used as the oscillator start-up stabilization timer.

## 5.3 Timer1 Interrupt

The TMR1 Register pair (TMR1H:TMR1L) increments from 0000h to FFFFh and rolls over to 0000h. The TMR1 interrupt, if enabled, is generated on overflow

which is latched in interrupt flag bit TMR1IF (PIR1<0>). This interrupt can be enabled/disabled by setting/clearing TMR1 interrupt enable bit TMR1IE (PIE1<0>).

## 5.4 Resetting Timer1 using an ECCP Trigger Output

If the ECCP module is configured in Compare mode to generate a “special event trigger” (CCP1M3:CCP1M0 = 1011), this signal will reset Timer1 and start an A/D conversion (if the A/D module is enabled).

**Note:** The special event triggers from the ECCP module will not set interrupt flag bit TMR1IF (PIR1<0>).

Timer1 must be configured for either Timer or Synchronized Counter mode to take advantage of this feature. If Timer1 is running in Asynchronous Counter mode, this Reset operation may not work.

In the event that a write to Timer1 coincides with a special event trigger from the ECCP, the write will take precedence.

In this mode of operation, the CCPR1H:CCPR1L register pair effectively becomes the period register for Timer1.

**TABLE 5-1: REGISTERS ASSOCIATED WITH TIMER1 AS A TIMER/COUNTER**

Address	Name	Bit 7	Bit 6	Bit 5	Bit 4	Bit 3	Bit 2	Bit 1	Bit 0	Value on POR, BOR	Value on all other Resets
0Bh,8Bh	INTCON	GIE	PEIE	T0IE	INTE	RBIE	T0IF	INTF	RBIF	0000 000x	0000 000u
0Ch	PIR1	—	ADIF	—	—	—	CCP1IF	TMR2IF	TMR1IF	-0-- -000	-0-- -000
8Ch	PIE1	—	ADIE	—	—	—	CCP1IE	TMR2IE	TMR1IE	-0-- -000	-0-- -000
0Eh	TMR1L	Holding register for the Least Significant Byte of the 16-bit TMR1 register								xxxx xxxx	uuuu uuuu
0Fh	TMR1H	Holding register for the Most Significant Byte of the 16-bit TMR1 register								xxxx xxxx	uuuu uuuu
10h	T1CON	—	—	T1CKPS1	T1CKPS0	T1OSCEN	T1SYNC	TMR1CS	TMR1ON	--00 0000	--uu uuuu

**Legend:** x = unknown, u = unchanged, - = unimplemented read as '0'. Shaded cells are not used by the Timer1 module.



## 6.0 TIMER2 MODULE

The Timer2 module timer has the following features:

- 8-bit timer (TMR2 register)
- 8-bit period register (PR2)
- Readable and writable (both registers)
- Software programmable prescaler (1:1, 1:4, 1:16)
- Software programmable postscaler (1:1 to 1:16)
- Interrupt on TMR2 match of PR2

Timer2 has a control register, shown in Register 6-1. Timer2 can be shut off by clearing control bit TMR2ON (T2CON<2>) to minimize power consumption.

Figure 6-1 is a simplified block diagram of the Timer2 module.

Additional information on timer modules is available in the PICmicro® Mid-Range Reference Manual, (DS33023).

### REGISTER 6-1: T2CON: TIMER2 CONTROL REGISTER (ADDRESS 12h)

U-0	R/W-0	R/W-0	R/W-0	R/W-0	R/W-0	R/W-0	R/W-0
—	TOUTPS3	TOUTPS2	TOUTPS1	TOUTPS0	TMR2ON	T2CKPS1	T2CKPS0
bit 7							bit 0

bit 7 **Unimplemented:** Read as '0'

bit 6-3 **TOUTPS3:TOUTPS0:** Timer2 Output Postscale Select bits

0000 = 1:1 Postscale  
 0001 = 1:2 Postscale  
 0010 = 1:3 Postscale  
 0011 = 1:4 Postscale  
 0100 = 1:5 Postscale  
 0101 = 1:6 Postscale  
 0110 = 1:7 Postscale  
 0111 = 1:8 Postscale  
 1000 = 1:9 Postscale  
 1001 = 1:10 Postscale  
 1010 = 1:11 Postscale  
 1011 = 1:12 Postscale  
 1100 = 1:13 Postscale  
 1101 = 1:14 Postscale  
 1110 = 1:15 Postscale  
 1111 = 1:16 Postscale

bit 2 **TMR2ON:** Timer2 On bit

1 = Timer2 is on  
 0 = Timer2 is off

bit 1-0 **T2CKPS1:T2CKPS0:** Timer2 Clock Prescale Select bits

00 = Prescaler is 1  
 01 = Prescaler is 4  
 1x = Prescaler is 16

#### Legend:

R = Readable bit	W = Writable bit	U = Unimplemented bit, read as '0'
-n = Value at POR	'1' = Bit is set	'0' = Bit is cleared    x = Bit is unknown

# PIC16F716

## 6.1 Timer2 Operation

Timer2 can be used as the PWM time base for PWM mode of the ECCP module.

The TMR2 register is readable and writable, and is cleared on any device Reset

The input clock ( $F_{osc}/4$ ) has a prescale option of 1:1, 1:4 or 1:16, selected by control bits T2CKPS1:T2CKPS0 (T2CON<1:0>).

The match output of TMR2 goes through a 4-bit postscaler (which gives a 1:1 to 1:16 scaling inclusive) to generate a TMR2 interrupt (latched in flag bit TMR2IF, (PIR1<1>)).

The prescaler and postscaler counters are cleared when any of the following occurs:

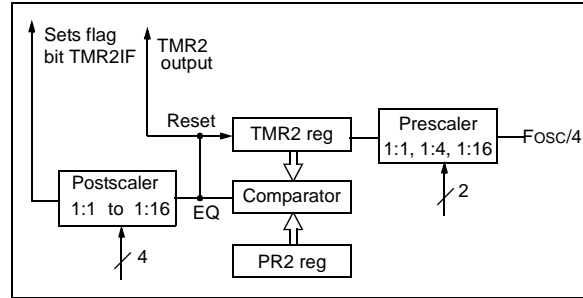
- A write to the TMR2 register
- A write to the T2CON register
- Any device Reset (Power-on Reset, MCLR Reset, Watchdog Timer Reset, or Brown-out Reset)

TMR2 is not cleared when T2CON is written.

## 6.2 Timer2 Interrupt

The Timer2 module has an 8-bit Period register (PR2). Timer2 increments from 00h until it matches PR2 and then resets to 00h on the next increment cycle. PR2 is a readable and writable register. The PR2 register is initialized to FFh upon Reset.

**FIGURE 6-1: TIMER2 BLOCK DIAGRAM**



**TABLE 6-1: REGISTERS ASSOCIATED WITH TIMER2 AS A TIMER/COUNTER**

Address	Name	Bit 7	Bit 6	Bit 5	Bit 4	Bit 3	Bit 2	Bit 1	Bit 0	Value on POR, BOR	Value on all other Resets
0Bh, 8Bh	INTCON	GIE	PEIE	TOIE	INTE	RBIE	TOIF	INTF	RBIF	0000 000x	0000 000u
0Ch	PIR1	—	ADIF	—	—	—	CCP1IF	TMR2IF	TMR1IF	-0-- -000	-0-- -000
8Ch	PIE1	—	ADIE	—	—	—	CCP1IE	TMR2IE	TMR1IE	-0-- -000	-0-- -000
11h	TMR2	Timer2 module's register								0000 0000	0000 0000
12h	T2CON	—	TOUTPS3	TOUTPS2	TOUTPS1	TOUTPS0	TMR2ON	T2CKPS1	T2CKPS0	-000 0000	-000 0000
92h	PR2	Timer2 Period Register								1111 1111	1111 1111

**Legend:** x = unknown, u = unchanged, - = unimplemented read as '0'. Shaded cells are not used by the Timer2 module.

## 7.0 ENHANCED CAPTURE/ COMPARE/PWM (ECCP) MODULE

The ECCP (Enhanced Capture/Compare/PWM) module contains a 16-bit register, which can operate as:

- 16-bit Capture register
- 16-bit Compare register
- PWM Master/Slave Duty Cycle register

Table 7-1 shows the timer resources of the ECCP module modes.

Capture/Compare/PWM Register 1 (CCPR1) is comprised of two 8-bit registers: CCPR1L (low byte) and CCPR1H (high byte).

The CCP1CON register controls ECCP operation. All the CCP1CON bits are readable and writable.

Additional information on the ECCP module is available in the PICmicro® Mid-Range Reference Manual, (DS33023).

**TABLE 7-1: ECCP MODE - TIMER RESOURCE**

ECCP Mode	Timer Resource
Capture	Timer1
Compare	Timer1
PWM	Timer2

### REGISTER 7-1: CCP1CON REGISTER (ADDRESS: 17h)

R/W-0	R/W-0	R/W-0	R/W-0	R/W-0	R/W-0	R/W-0	R/W-0	
P1M1	P1M0	DC1B1	DC1B0	CCP1M3	CCP1M2	CCP1M1	CCP1M0	
							bit 7	bit 0

- bit 7-6 **P1M1:P1M0**: PWM Output Configuration bits  
**CCP1M<3:2> = 00, 01, 10**  
 xx = P1A assigned as Capture/Compare I/O. P1B, P1C, P1D assigned as Port pins.  
**CCP1M<3:2> = 11**  
 00 = Single output, P1A modulated. P1B, P1C, P1D assigned as Port pins.  
 01 = Quad output forward. P1D modulated, P1A active. P1B and P1C inactive.  
 10 = Dual output. P1A, P1B modulated with dead-time control. P1C, P1D assigned as port pins.  
 11 = Quad output reverse. P1B modulated, P1C active. P1A and P1D inactive.
- bit 5-4 **DC1B1:DC1B0**: PWM Least Significant bits  
 Capture mode: Unused  
 Compare mode: Unused  
 PWM mode: These bits are the two LSBs of the PWM duty cycle. The eight MSBs are found in CCPR1L.
- bit 3-0 **CCP1M3:CCP1M0**: ECCP Mode Select bits  
 0000 = Capture/Compare/PWM off (resets ECCP module)  
 0001 = Unused (Reserved)  
 0010 = Compare mode, toggle output on match (CCP1IF bit is set)  
 0011 = Unused (Reserved)  
 0100 = Capture mode, every falling edge  
 0101 = Capture mode, every rising edge  
 0110 = Capture mode, every 4th rising edge  
 0111 = Capture mode, every 16th rising edge  
 1000 = Compare mode, set CCP1 output on match (CCP1IF bit is set)  
 1001 = Compare mode, clear CCP1 output on match (CCP1IF bit is set)  
 1010 = Compare mode, generate software interrupt on match (CCP1IF bit is set, CCP1 pin is unaffected)  
 1011 = Compare mode, trigger special event (CCP1IF bit is set, TMR1 is reset, and an A/D conversion is started if the A/D module is enabled. CCP1 pin is unaffected).  
 1100 = PWM mode. P1A, P1C active-high; P1B, P1D active-high.  
 1101 = PWM mode. P1A, P1C active-high; P1B, P1D active-low.  
 1110 = PWM mode. P1A, P1C active-low; P1B, P1D active-high.  
 1111 = PWM mode. P1A, P1C active-low; P1B, P1D active-low.

<b>Legend:</b>			
R = Readable bit	W = Writable bit	U = Unimplemented bit, read as '0'	
-n = Value at POR	'1' = Bit is set	'0' = Bit is cleared	x = Bit is unknown

# PIC16F716

## 7.1 Capture Mode

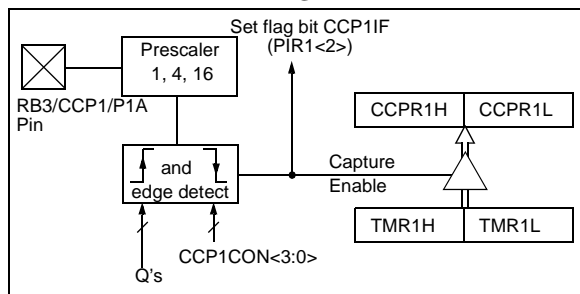
In Capture mode, CCPR1H:CCPR1L captures the 16-bit value of the TMR1 register when an event occurs on pin RB3/CCP1/P1A. An event is defined as:

- Every falling edge
- Every rising edge
- Every 4th rising edge
- Every 16th rising edge

An event is selected by control bits CCP1M3:CCP1M0 (CCP1CON<3:0>). When a capture is made, the interrupt request flag bit CCP1IF (PIR1<2>) is set. It must be cleared in software. If another capture occurs before the value in register CCPR1 is read, the old captured value will be lost.

**Note:** Always reset the ECCP module (CCP1M3:CCP1M0 = '0000') between changing from one capture mode to another. This is necessary to reset the internal capture counter.

**FIGURE 7-1: CAPTURE MODE OPERATION BLOCK DIAGRAM**



### 7.1.1 CCP1 PIN CONFIGURATION

In Capture mode, the RB3/CCP1/P1A pin should be configured as an input by setting the TRISB<3> bit.

**Note:** If the RB3/CCP1/P1A is configured as an output, a write to PORTB can cause a capture condition.

### 7.1.2 TIMER1 MODE SELECTION

Timer1 must be running in Timer mode or Synchronized Counter mode for the ECCP module to use the capture feature. In Asynchronous Counter mode, the capture operation may not work.

### 7.1.3 SOFTWARE INTERRUPT

When the Capture mode is changed, a false capture interrupt may be generated. The user should keep bit CCP1IE (PIE1<2>) clear to avoid false interrupts and should clear the flag bit CCP1IF following any such change in operating mode.

### 7.1.4 ECCP PRESCALER

There are four prescaler settings, specified by bits CCP1M3:CCP1M0. Whenever the ECCP module is turned off, or the ECCP module is not in Capture mode, the prescaler counter is cleared. This means that any Reset will clear the prescaler counter.

Switching from one capture prescaler to another may generate an interrupt. Also, the prescaler counter will not be cleared, therefore, the first capture may be from a non-zero prescaler. Example 7-1 shows the recommended method for switching between capture prescalers. This example also clears the prescaler counter and will not generate the "false" interrupt.

#### EXAMPLE 7-1: CHANGING BETWEEN CAPTURE PRESCALERS

```
CLRWF CCP1CON ;Turn ECCP module off
MOVLW NEW_CAPT_PS ;Load the W reg with
;the new prescaler
;mode value and ECCP ON
MOVWF CCP1CON ;Load CCP1CON with this
;value
```

## 7.2 Compare Mode

In Compare mode, the 16-bit CCPR1 register value is constantly compared against the TMR1 register pair value. When a match occurs, the RB3/CCP1/P1A pin is either:

- Driven High
- Driven Low
- Toggle output (high-to-low or low-to-high)
- Remains Unchanged

The action on the pin is based on the value of control bits CCP1M3:CCP1M0 (CCP1CON<3:0>). At the same time, interrupt flag bit CCP1IF is set.

Changing the ECCP mode to clear output on match (CCP1M<3:0> = 1000) presets the CCP1 output latch to the logic 1 level. Changing the ECCP mode to set output on match (CCP1M<3:0> = 1001) presets the CCP1 output latch to the logic 0 level.

## 7.2.1 CCP1 PIN CONFIGURATION

The user must configure the RB3/CCP1/P1A pin as the CCP1 output by clearing the TRISB<3> bit.

**Note:** Clearing the CCP1CON register will force the RB3/CCP1/P1A compare output latch to the default low level. This is not the PORTB I/O data latch.

## 7.2.2 TIMER1 MODE SELECTION

Timer1 must be running in Timer mode or Synchronized Counter mode if the ECCP module is using the compare feature. In Asynchronous Counter mode, the compare operation may not work.

## 7.2.3 SOFTWARE INTERRUPT MODE

When Generate Software Interrupt mode is chosen, the CCP1 pin is not affected. Only a CCP interrupt is generated (if enabled).

## 7.2.4 SPECIAL EVENT TRIGGER

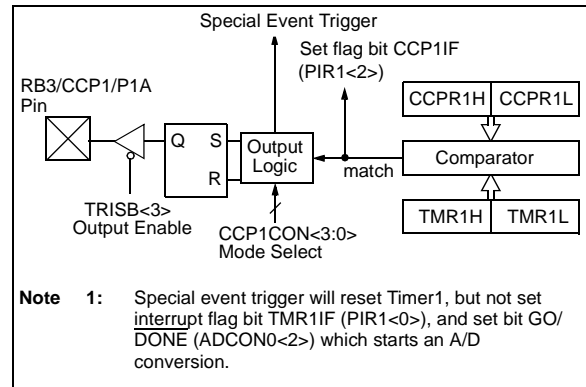
In this mode, an internal hardware trigger is generated which may be used to initiate an action.

The special event trigger output of the ECCP resets the TMR1 register pair. This allows the CCPR1 register to effectively be a 16-bit programmable period register for Timer1.

The special event trigger output of the ECCP also starts an A/D conversion (if the A/D module is enabled).

**Note:** The special event trigger from the ECCP module will not set interrupt flag bit TMR1IF (PIR1<0>).

**FIGURE 7-2: COMPARE MODE OPERATION BLOCK DIAGRAM**



**TABLE 7-2: REGISTERS ASSOCIATED WITH CAPTURE, COMPARE, AND TIMER1**

Address	Name	Bit 7	Bit 6	Bit 5	Bit 4	Bit 3	Bit 2	Bit 1	Bit 0	Value on POR, BOR	Value on all other Resets
0Bh,8Bh	INTCON	GIE	PEIE	T0IE	INTE	RBIE	T0IF	INTF	RBIF	0000 000x	0000 000u
0Ch	PIR1	—	ADIF	—	—	—	CCP1IF	TMR2IF	TMR1IF	-0-- -000	-0-- -000
0Eh	TMR1L	Holding register for the Least Significant Byte of the 16-bit TMR1 register								xxxx xxxx	uuuu uuuu
0Fh	TMR1H	Holding register for the Most Significant Byte of the 16-bit TMR1 register								xxxx xxxx	uuuu uuuu
10h	T1CON	—	—	T1CKPS1	T1CKPS0	T1OSCEN	T1SYN $\bar{C}$	TMR1CS	TMR1ON	--00 0000	--uu uuuu
15h	CCPR1L	Capture/Compare/PWM register1 (LSB)								xxxx xxxx	uuuu uuuu
16h	CCPR1H	Capture/Compare/PWM register1 (MSB)								xxxx xxxx	uuuu uuuu
17h	CCP1CON	P1M1	P1M0	DC1B1	DC1B0	CCP1M3	CCP1M2	CCP1M1	CCP1M0	0000 0000	0000 0000
86h	TRISB	PORTB Data direction register								1111 1111	1111 1111
8Ch	PIE1	—	ADIE	—	—	—	CCP1IE	TMR2IE	TMR1IE	-0-- -000	-0-- -000

**Legend:** x = unknown, u = unchanged, - = unimplemented read as '0'. Shaded cells are not used by Capture and Timer1.

# PIC16F716

## 7.3 PWM Mode

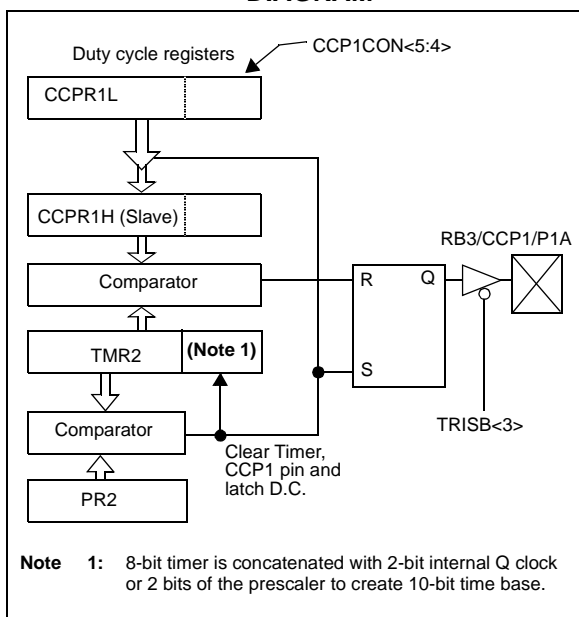
In Pulse Width Modulation (PWM) mode, the CCP1 pin produces up to a 10-bit resolution PWM output. Since the CCP1 pin is multiplexed with the PORTB data latch, the TRISB<3> bit must be cleared to make the CCP1 pin an output.

**Note:** Clearing the CCP1CON register will force the CCP1 PWM output latch to the default low level. This is not the PORTB I/O data latch.

Figure 7-3 shows a simplified block diagram of the CCP module in PWM mode.

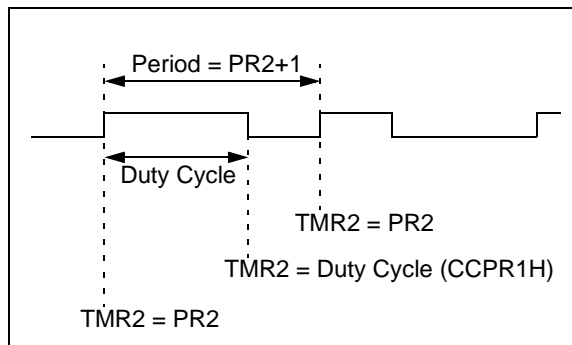
For a step-by-step procedure on how to setup the ECCP module for PWM operation, see **Section 7.3.3 “Set-Up for PWM Operation”**.

**FIGURE 7-3: SIMPLIFIED PWM BLOCK DIAGRAM**



A PWM output (Figure 7-4) has a time base (period) and a time that the output stays high (duty cycle). The frequency of the PWM is the inverse of the period (1/period).

**FIGURE 7-4: PWM OUTPUT**



### 7.3.1 PWM PERIOD

The PWM period is specified by writing to the PR2 register. The PWM period can be calculated using the following formula:

**EQUATION 7-1:**

$$\text{PWM Period} = [(PR2) + 1] \cdot 4 \cdot T_{osc} \cdot (\text{TMR2 prescale value})$$

PWM frequency is defined as 1/[PWM period].

When TMR2 is equal to PR2, the following three events occur on the next increment cycle:

- TMR2 is cleared
- The CCP1 pin is set (exception: if PWM duty cycle = 0%, the CCP1 pin will not be set)
- The PWM duty cycle is latched from CCPR1L into CCPR1H

**Note:** The Timer2 postscaler (see **Section 6.0 “Timer2 Module”**) is not used in the determination of the PWM frequency. The postscaler could be used to have a servo update rate at a different frequency than the PWM output.

## 7.3.2 PWM DUTY CYCLE

The PWM duty cycle is specified by writing to the CCP1L register and to the CCP1CON<5:4> bits. Up to 10-bit resolution is available. The CCP1L contains the eight MSBs and the CCP1CON<5:4> contains the two LSBs. This 10-bit value is represented by CCP1L:CCP1CON<5:4>. The following equation is used to calculate the PWM duty cycle in time:

**EQUATION 7-2:**

$$\text{PWM Duty Cycle} = (\text{CCP1L:CCP1CON}\langle 5:4 \rangle \cdot \text{TOSC} \cdot (\text{TMR2 prescale value}))$$

CCP1L and CCP1CON<5:4> can be written to at any time, but the duty cycle value is not latched into CCP1H until a match between PR2 and TMR2 occurs (i.e., the period is complete). In PWM mode, CCP1H is a read-only register.

The CCP1H register and a 2-bit internal latch are used to double buffer the PWM duty cycle. This double buffering is essential for glitchless PWM operation.

When the CCP1H and 2-bit latch match TMR2 concatenated with an internal 2-bit Q clock or 2 bits of the TMR2 prescaler, the CCP1 pin is cleared.

Maximum PWM resolution (bits) for a given PWM frequency is given by the following equation:

**EQUATION 7-3:**

$$\text{Max resolution} = \frac{\log\left(\frac{F_{\text{OSC}}}{F_{\text{PWM}}}\right)}{\log(2)} \text{ bits}$$

**Note:** If the PWM duty cycle value is longer than the PWM period the CCP1 pin will not be cleared.

For an example PWM period and duty cycle calculation, see the PICmicro® Mid-Range Reference Manual, (DS33023).

## 7.3.3 SET-UP FOR PWM OPERATION

The following steps should be taken when configuring the ECCP module for PWM operation:

1. Set the PWM period by writing to the PR2 register.
2. Set the PWM duty cycle by writing to the CCP1L register and CCP1CON<5:4> bits.
3. Make the CCP1 pin an output by clearing the TRISB<3> bit.
4. Set the TMR2 prescale value and enable Timer2 by writing to T2CON.
5. Configure the CCP1 module for PWM operation.

**TABLE 7-3: EXAMPLE PWM FREQUENCIES AND RESOLUTIONS AT 20 MHz**

PWM Frequency	1.22 kHz	4.88 kHz	19.53 kHz	78.12 kHz	156.3 kHz	208.3 kHz
Timer Prescaler (1, 4, 16)	16	4	1	1	1	1
PR2 Value	0xFF	0xFF	0xFF	0x3F	0x1F	0x17
Maximum Resolution (bits)	10	10	10	8	7	6.6

**TABLE 7-4: REGISTERS ASSOCIATED WITH PWM AND TIMER2**

Address	Name	Bit 7	Bit 6	Bit 5	Bit 4	Bit 3	Bit 2	Bit 1	Bit 0	Value on POR, BOR	Value on all other Resets
0Bh,8Bh	INTCON	GIE	PEIE	T0IE	INTE	RBIE	T0IF	INTF	RBIF	0000 000x	0000 000u
0Ch	PIR1	—	ADIF	—	—	—	CCP1IF	TMR2IF	TMR1IF	-0-- -000	-0-- -000
11h	TMR2	Timer2 module's register								0000 0000	0000 0000
12h	T2CON	—	TOUTPS3	TOUTPS2	TOUTPS1	TOUTPS0	TMR2ON	T2CKPS1	T2CKPS0	-000 0000	-000 0000
15h	CCP1L	Capture/Compare/PWM register1 (LSB)								xxxx xxxx	uuuu uuuu
16h	CCP1H	Capture/Compare/PWM register1 (MSB)								xxxx xxxx	uuuu uuuu
17h	CCP1CON	P1M1	P1M0	DC1B1	DC1B0	CCP1M3	CCP1M2	CCP1M1	CCP1M0	0000 0000	0000 0000
86h	TRISB	PORB Data direction register								1111 1111	1111 1111
8Ch	PIE1	—	ADIE	—	—	—	CCP1IE	TMR2IE	TMR1IE	-0-- -000	-0-- -000
92h	PR2	Timer2 module's period register								1111 1111	1111 1111

**Legend:** x = unknown, u = unchanged, - = unimplemented read as '0'. Shaded cells are not used by PWM and Timer2.

# PIC16F716

## 7.4 ENHANCED PWM MODE

The Enhanced PWM mode provides additional PWM output options for a broader range of control applications. The module is an upwardly compatible version of the standard CCP module and offers up to four outputs, designated P1A through P1D. Users are also able to select the polarity of the signal (either active-high or active-low). The module's Output mode and polarity are configured by setting the P1M1:P1M0 and CCP1M3:CCP1M0 bits of the CCP1CON register (CCP1CON<7:6> and CCP1CON<3:0>, respectively).

Figure 7-5 shows a simplified block diagram of PWM operation. All control registers are double buffered and are loaded at the beginning of a new PWM cycle (the period boundary when Timer2 resets) in order to prevent glitches on any of the outputs. The exception is the PWM Dead-band Delay, which is loaded at either the duty cycle boundary or the boundary period (whichever comes first). Because of the buffering, the module waits until the assigned timer resets, instead of starting immediately. This means that enhanced PWM waveforms do not exactly match the standard PWM waveforms, but are instead offset by one full instruction cycle (4 TOSC).

As before, the user must manually configure the appropriate TRISB bits for output.

### 7.4.1 PWM OUTPUT CONFIGURATIONS

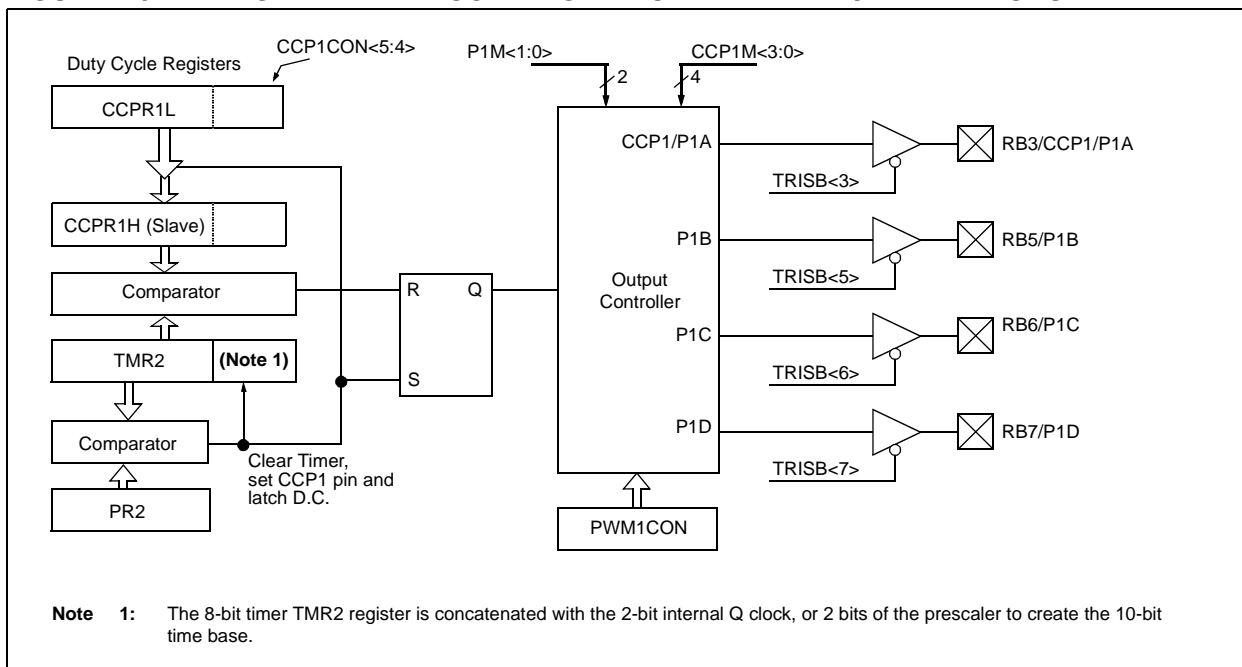
The P1M1:P1M0 bits in the CCP1CON register allows one of four configurations:

- Single Output
- Half-Bridge Output
- Full-Bridge Output Forward mode
- Full-Bridge Output Reverse mode

The Single Output mode is the Standard PWM mode discussed in **Section 7.3 "PWM Mode"**. The Half-Bridge and Full-Bridge Output modes are covered in detail in the sections that follow.

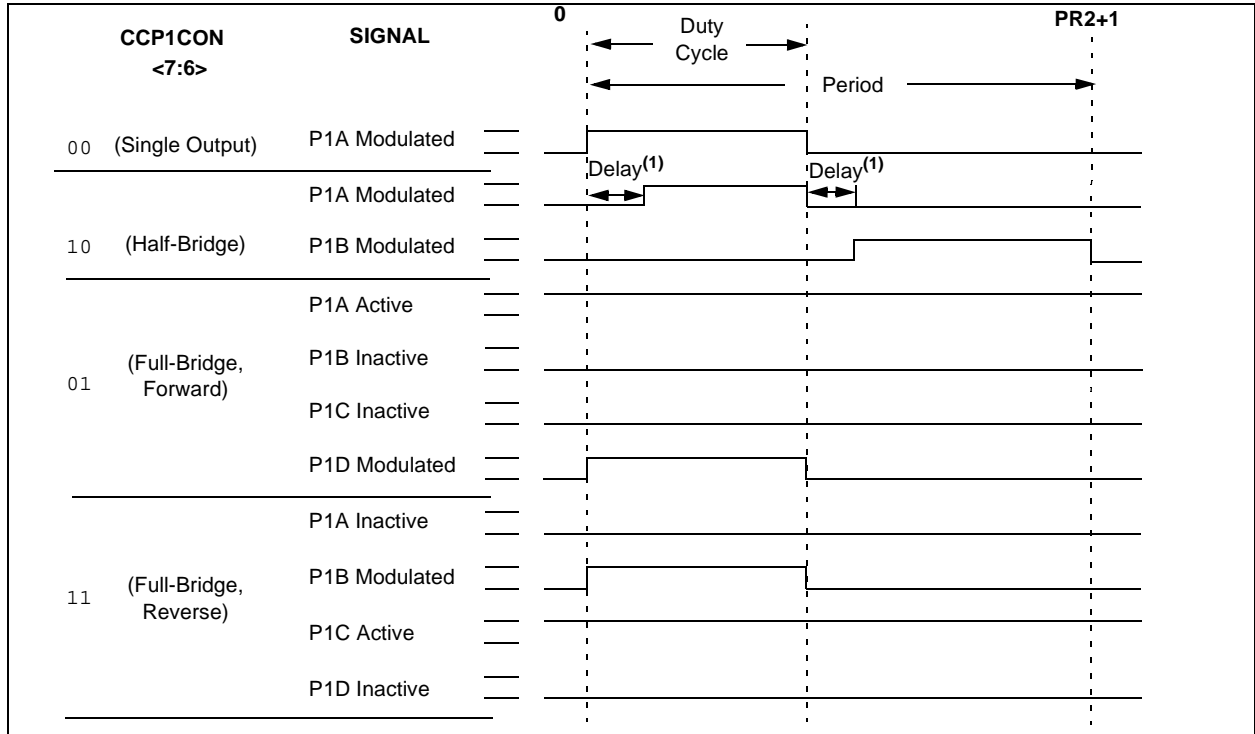
The general relationship of the outputs in all configurations is summarized in Figure 7-6.

**FIGURE 7-5: SIMPLIFIED BLOCK DIAGRAM OF THE ENHANCED PWM MODULE**

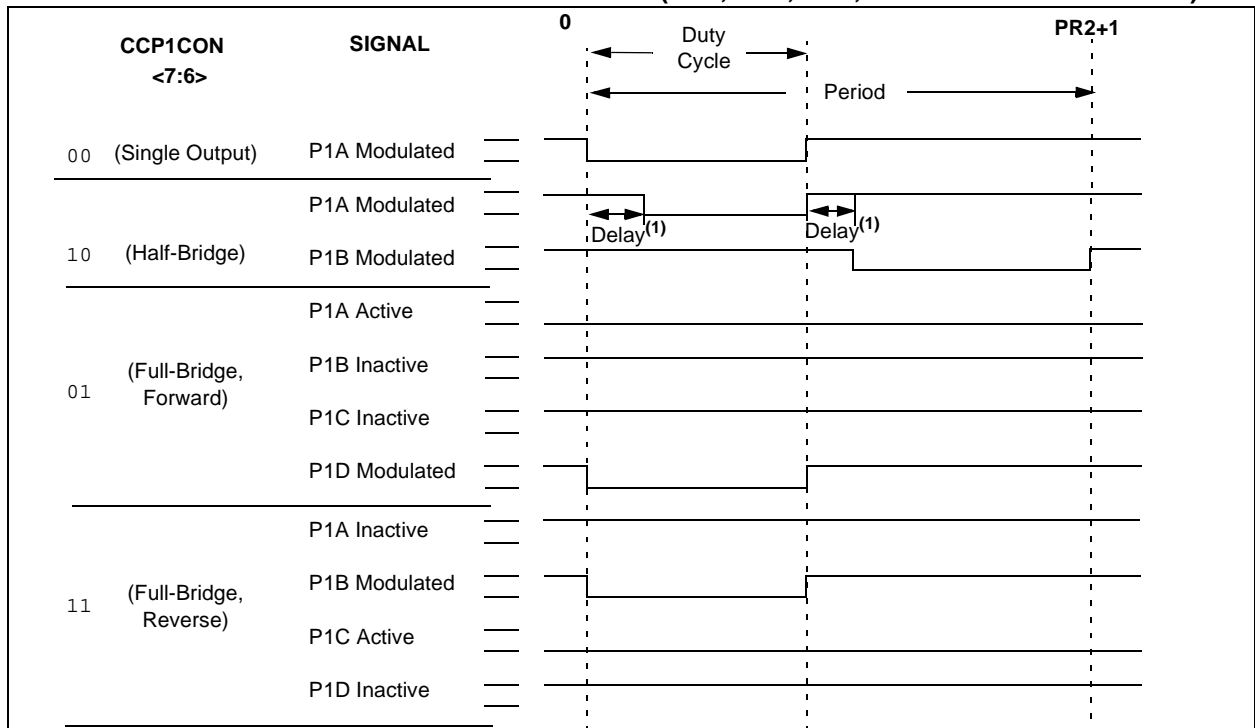




**FIGURE 7-6: PWM OUTPUT RELATIONSHIPS (P1A, P1B, P1C, P1D ACTIVE-HIGH STATE)**



**FIGURE 7-7: PWM OUTPUT RELATIONSHIPS (P1A, P1B, P1C, P1D ACTIVE-LOW STATE)**



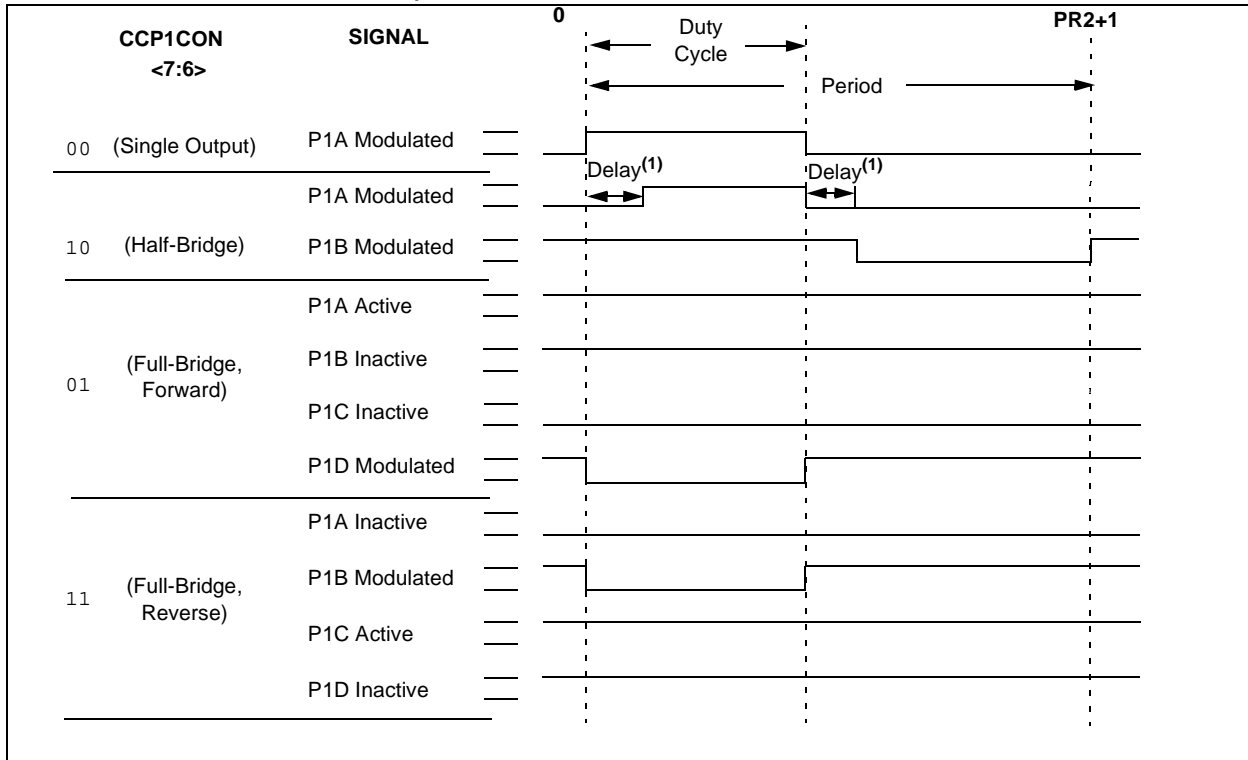
Relationships:

- Period = 4 \* T<sub>osc</sub> \* (PR2 + 1) \* (TMR2 prescale value)
- Duty Cycle = T<sub>osc</sub> \* (CCPR1L<7:0> : CCP1CON<5:4>) \* (TMR2 prescale value)
- Delay = 4 \* T<sub>osc</sub> \* (PWM1CON<6:0>)

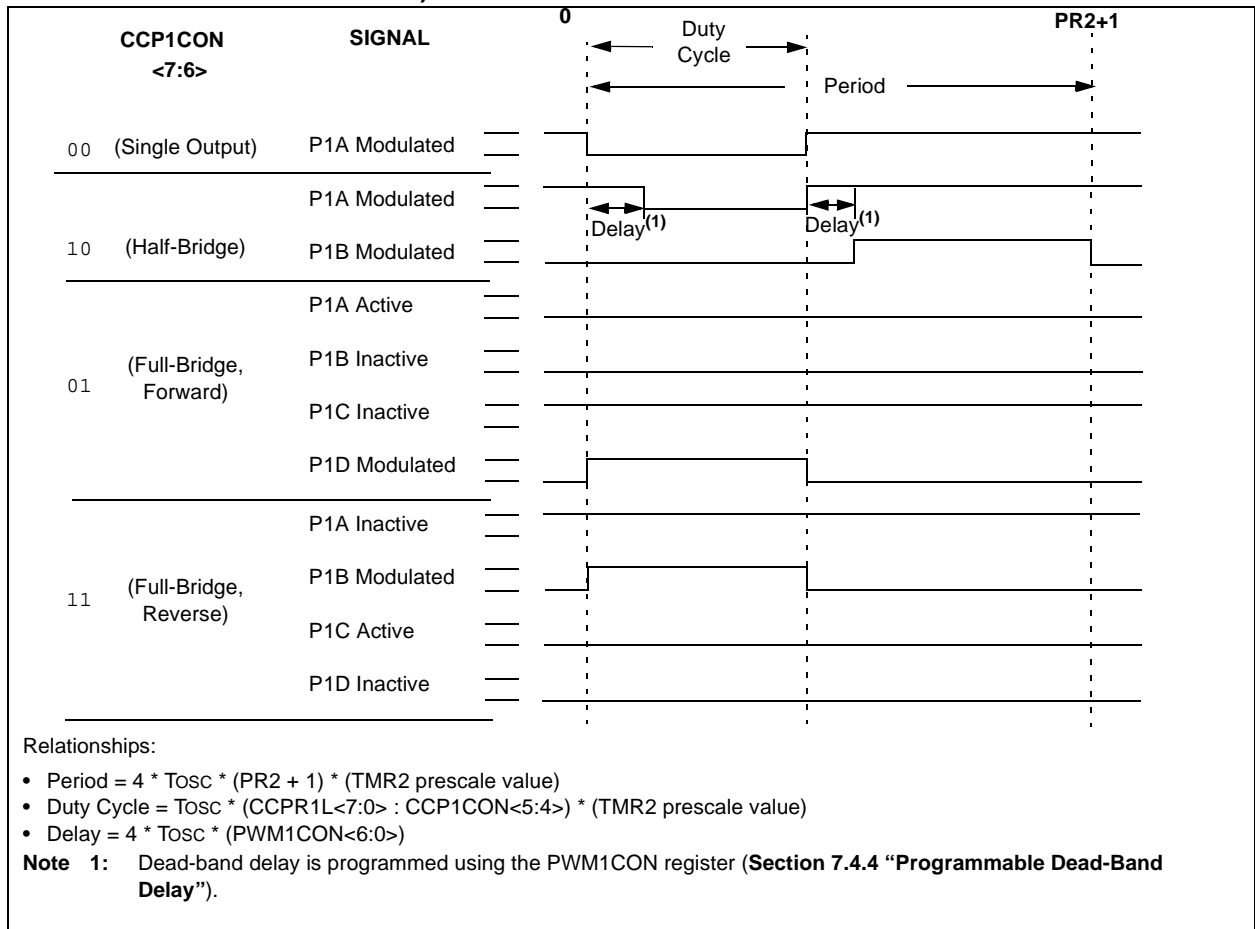
**Note 1:** Dead-band delay is programmed using the PWM1CON register (**Section 7.4.4 “Programmable Dead-Band Delay”**).

# PIC16F716

**FIGURE 7-8: PWM OUTPUT RELATIONSHIPS (P1A, P1C ACTIVE-HIGH. P1B, P1D ACTIVE-LOW)**



**FIGURE 7-9: PWM OUTPUT RELATIONSHIPS (P1A, P1C ACTIVE-LOW. P1B, P1D ACTIVE-HIGH)**



# PIC16F716

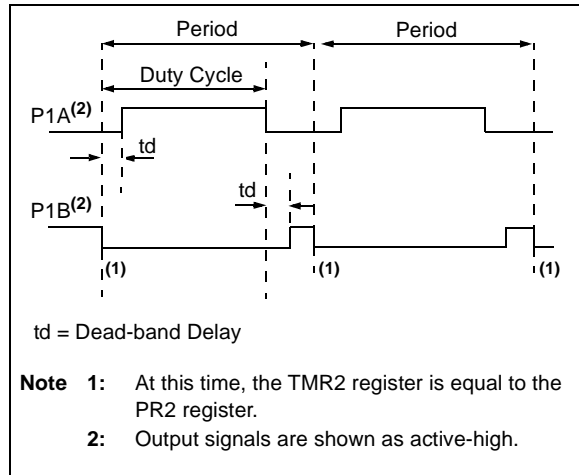
## 7.4.2 HALF-BRIDGE MODE

In the Half-Bridge Output mode, two pins are used as outputs to drive push-pull loads. The PWM output signal is output on the RB3/CCP1/P1A pin, while the complementary PWM output signal is output on the RB5/P1B pin (Figure 7-12). This mode can be used for half-bridge applications, as shown in Figure 7-11 or for full-bridge applications, where four power switches are being modulated with two PWM signals.

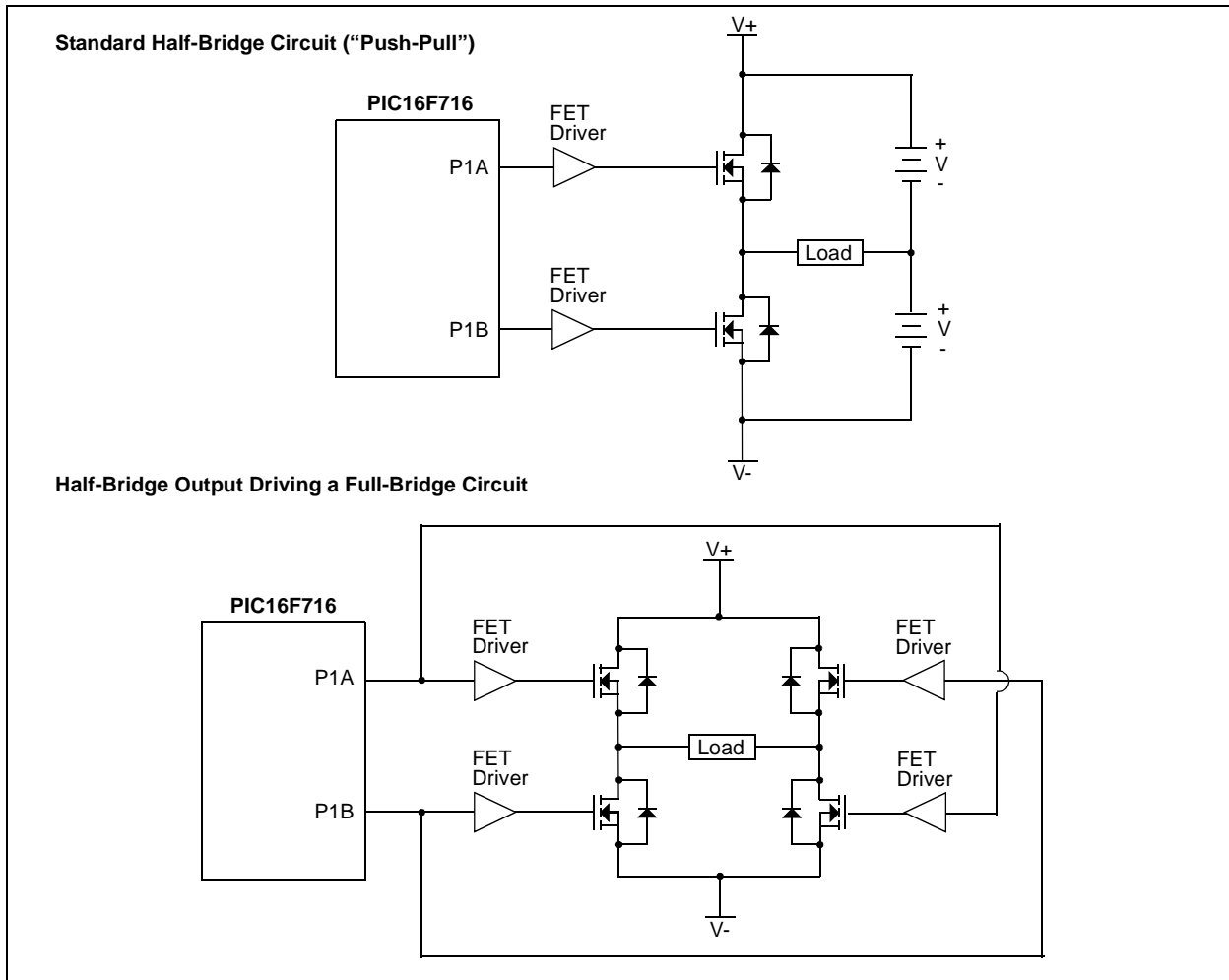
In Half-Bridge Output mode, the programmable dead-band delay can be used to prevent shoot-through current in half-bridge power devices. The value of PWM1CON bits PDC6:PDC0 sets the number of instruction cycles before the output is driven active. If the value is greater than the duty cycle, the corresponding output remains inactive during the entire cycle. See **Section 7.4.4 “Programmable Dead-Band Delay”** for more details of the dead-band delay operations.

Since the P1A and P1B outputs are multiplexed with the PORTB<3> and PORTB<5> data latches, the TRISB<3> and TRISB<5> bits must be cleared to configure P1A and P1B as outputs.

**FIGURE 7-10: HALF-BRIDGE PWM OUTPUT**



**FIGURE 7-11: EXAMPLES OF HALF-BRIDGE OUTPUT MODE APPLICATIONS**

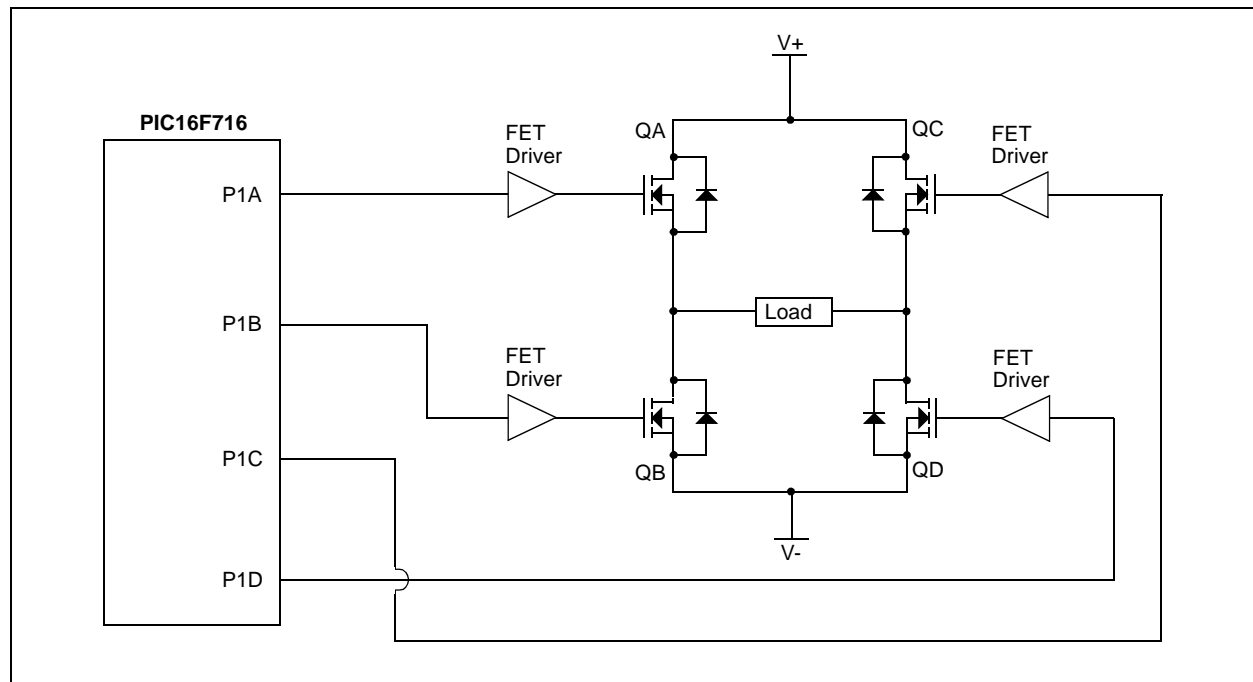


## 7.4.3 FULL-BRIDGE MODE

In Full-Bridge Output mode, four pins are used as outputs; however, only two outputs are active at a time. In the Forward mode, pin RB3/CCP1/P1A is continuously active, and pin RB7/P1D is modulated. In the Reverse mode, RB6/P1C pin is continuously active, and RB5/P1B pin is modulated. These are illustrated in Figure 7-6 through Figure 7-9.

P1A, P1B, P1C and P1D outputs are multiplexed with the PORTB<3> and PORTB<5:7> data latches. The TRISB<3> and TRISB<5:7> bits must be cleared to make the P1A, P1B, P1C, and P1D pins output.

**FIGURE 7-12: EXAMPLE OF FULL-BRIDGE APPLICATION**



### 7.4.3.1 Direction Change in Full-Bridge Mode

In the Full-Bridge Output mode, the P1M1 bit in the CCP1CON register allows the user to control the Forward/Reverse direction. When the application firmware changes this direction control bit, the module will assume the new direction on the next PWM cycle.

Just before the end of the current PWM period, the modulated outputs (P1B and P1D) are placed in their inactive state, while the unmodulated outputs (P1A and P1C) are switched to drive in the opposite direction. This occurs in a time interval of  $(4 \cdot T_{OSC} \cdot (\text{Timer2 Prescale value}))$  before the next PWM period begins. The Timer2 prescaler will be either 1, 4 or 16, depending on the value of the T2CKPSx bits (T2CON<1:0>). During the interval from the switch of the unmodulated outputs to the beginning of the next period, the modulated outputs (P1B and P1D) remain inactive. This relationship is shown in Figure 7-13.

**Note:** In the Full-Bridge Output mode, the ECCP module does not provide any dead-band delay. In general, since only one output is modulated at all times, dead-band delay is not required. However, there is a situation where a dead-band delay might be required. This situation occurs when both of the following conditions are true:

1. The direction of the PWM output changes when the duty cycle of the output is at or near 100%.
2. The turn off time of the power switch, including the power device and driver circuit, is greater than the turn on time.

# PIC16F716

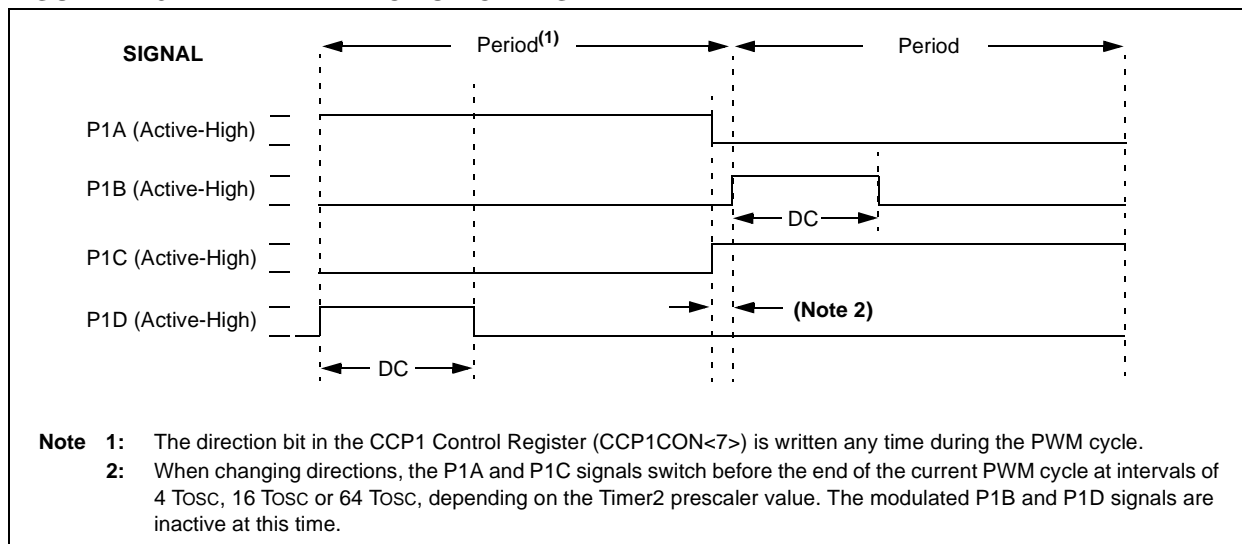
Figure 7-14 shows an example where the PWM direction changes from forward to reverse, at a near 100% duty cycle. At time  $t_1$ , the output P1A and P1D become inactive, while output P1C becomes active. In this example, since the turn-off time of the power devices is longer than the turn-on time, a shoot-through current may flow through power devices QC and QD (see Figure 7-12) for the duration of 't'. The same phenomenon will occur to power devices QA and QB for PWM direction change from reverse to forward.

If changing PWM direction at high duty cycle is required for an application, one of the following requirements must be met:

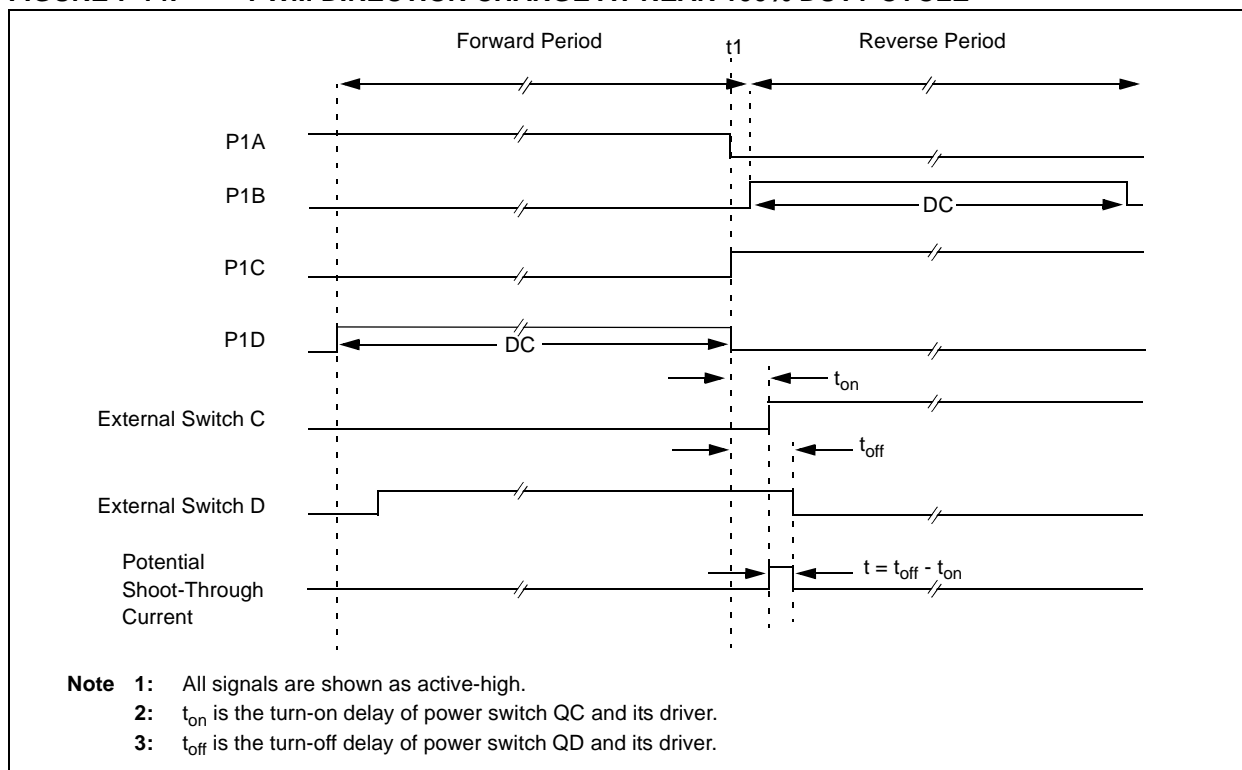
1. Reduce PWM for a PWM period before changing directions.
2. Use switch drivers that can drive the switches off faster than they can drive them on.

Other options to prevent shoot-through current may exist.

**FIGURE 7-13: PWM DIRECTION CHANGE**



**FIGURE 7-14: PWM DIRECTION CHANGE AT NEAR 100% DUTY CYCLE**



## 7.4.4 PROGRAMMABLE DEAD-BAND DELAY

In half-bridge applications where all power switches are modulated at the PWM frequency at all times, the power switches normally require more time to turn off than to turn on. If both the upper and lower power switches are switched at the same time (one turned on, and the other turned off), both switches may be on for a short period of time until one switch completely turns off. During this brief interval, a very high current (*shoot-through current*) may flow through both power switches, shorting the bridge supply. To avoid this potentially destructive shoot-through current from flowing during switching, turning on either of the power switches is normally delayed to allow the other switch to completely turn off.

In the Half-Bridge Output mode, a digitally programmable dead-band delay is available to avoid shoot-through current from destroying the bridge power switches. The delay occurs at the signal transition from the non-active state to the active state. See Figure 7-10 for illustration. The lower seven bits of the PWM1CON register (Register 7-2) sets the delay period in terms of microcontroller instruction cycles (TCY or 4 TOSC).

## 7.4.5 ENHANCED PWM AUTO-SHUTDOWN

When the ECCP is programmed for any of the enhanced PWM modes, the active output pins may be configured for auto-shutdown. Auto-shutdown immediately places the enhanced PWM output pins into a defined shutdown state when a shutdown event occurs.

A shutdown event can be caused by a logic low level on either or both of the RB0/INT/ECCPAS2 or RB4/ECCPAS0 pins. The auto-shutdown feature can be disabled by not selecting any auto-shutdown sources. The auto-shutdown sources to be used are selected using the ECCPAS2 and ECCPAS0 bits (ECCPAS<6> and ECCPAS<4>).

When a shutdown occurs, the output pins are asynchronously placed in their shutdown states, specified by the PSSAC1:PSSAC0 and PSSBD1:PSSBD0 bits (ECCPAS<3:0>). Each pin pair (P1A/P1C and P1B/P1D) may be set to drive high, drive low, or be tri-stated (not driving). The ECCPASE bit (ECCPAS<7>) is also set to hold the enhanced PWM outputs in their shutdown states.

The ECCPASE bit is set by hardware when a shutdown event occurs. If automatic restarts are not enabled, the ECCPASE bit must be cleared by firmware when the cause of the shutdown clears. If automatic restarts are enabled, the ECCPASE bit is automatically cleared when the cause of the auto-shutdown has cleared.

If the ECCPASE bit is set when a PWM period begins, the PWM outputs remain in their shutdown state for that entire PWM period. When the ECCPASE bit is cleared, the PWM outputs will return to normal operation at the beginning of the next PWM period.

**Note:** Writing to the ECCPASE bit is disabled while a shutdown condition is active.

# PIC16F716

## REGISTER 7-2: PWM1CON: PWM CONFIGURATION REGISTER (ADDRESS: 18h)

R/W-0	R/W-0	R/W-0	R/W-0	R/W-0	R/W-0	R/W-0	R/W-0
PRSEN	PDC6	PDC5	PDC4	PDC3	PDC2	PDC1	PDC0
bit 7							bit 0

- bit 7     **PRSEN:** PWM Restart Enable bit  
 1 = Upon auto-shutdown, the ECCPASE bit clears automatically once the shutdown event goes away; the PWM restarts automatically.  
 0 = Upon auto-shutdown, ECCPASE must be cleared in firmware to restart the PWM.
- bit 6-0   **PDC<6:0>:** PWM Delay Count bits  
 Number of FOSC/4 (4\*TOSC) cycles between the scheduled time when a PWM signal **should** transition active, and the **actual** time it transitions active.

<b>Legend:</b>			
R = Readable bit	W = Writable bit	U = Unimplemented bit, read as '0'	
- n = Value at POR	'1' = Bit is set	'0' = Bit is cleared	x = Bit is unknown

## REGISTER 7-3: ECCPAS – ENHANCED CCP AUTO SHUT DOWN REGISTER (ADDRESS: 19h)

R/W-0	R/W-0	U-0	R/W-0	R/W-0	R/W-0	R/W-0	R/W-0
ECCPASE	ECCPAS2	—	ECCPAS0	PSSAC1	PSSAC0	PSSBD1	PSSBD0
bit 7							bit 0

- bit 7     **ECCPASE:** ECCP Auto-Shutdown Event Status bit  
 1 = A shutdown event has occurred. Must be reset in firmware to re-enable ECCP if PRSEN = 0  
 0 = ECCP outputs enabled, no shutdown event
- bit 6     **ECCPAS2:** ECCP Auto-Shutdown bit 2  
 1 = RB0 (INT) pin low level ('0') causes shutdown  
 0 = RB0 (INT) pin has no effect on ECCP
- bit 5     **Unimplemented:** Read as '0'
- bit 4     **ECCPAS0:** ECCP Auto-Shutdown bit '0'  
 1 = RB4 pin low level ('0') causes shutdown  
 0 = RB4 pin has no effect on ECCP
- bit 3-2   **PSSAC<1:0>:** Pin P1A and P1C Shutdown State Control  
 00 = Drive Pins P1A and P1C to '0'  
 01 = Drive Pins P1A and P1C to '1'  
 1x = Pins P1A and P1C tri-state
- bit 1-0   **PSSBD<1:0>:** Pin P1B and P1D Shutdown State Control  
 00 = Drive Pins P1B and P1D to '0'  
 01 = Drive Pins P1B and P1D to '1'  
 1x = Pins P1B and P1D tri-state

<b>Legend:</b>			
R = Readable bit	W = Writable bit	U = Unimplemented bit, read as '0'	
- n = Value at POR	'1' = Bit is set	'0' = Bit is cleared	x = Bit is unknown



## 7.4.5.1 Auto-Shutdown and Automatic Restart

The auto-shutdown feature can be configured to allow automatic restarts of the module following a shutdown event. This is enabled by setting the PRSEN bit of the PWM1CON register (PWM1CON<7>).

In Shutdown mode with PRSEN = 1 (PWM1CON <7>) (Figure 7-15), the ECCPASE bit will remain set for as long as the cause of the shutdown continues. When the shutdown condition clears, the ECCPASE bit is cleared. If PRSEN = 0 (Figure 7-16), once a shutdown condition occurs, the ECCPASE bit will remain set until it is cleared by firmware. Once ECCPASE is cleared, the enhanced PWM will resume at the beginning of the next PWM period.

**Note:** Writing to the ECCPASE bit is disabled while a shutdown condition is active.

The ECCPASE bit cannot be cleared as long as the cause of the shutdown persists.

The Auto-shutdown mode can be forced by writing a '1' to the ECCPASE bit.

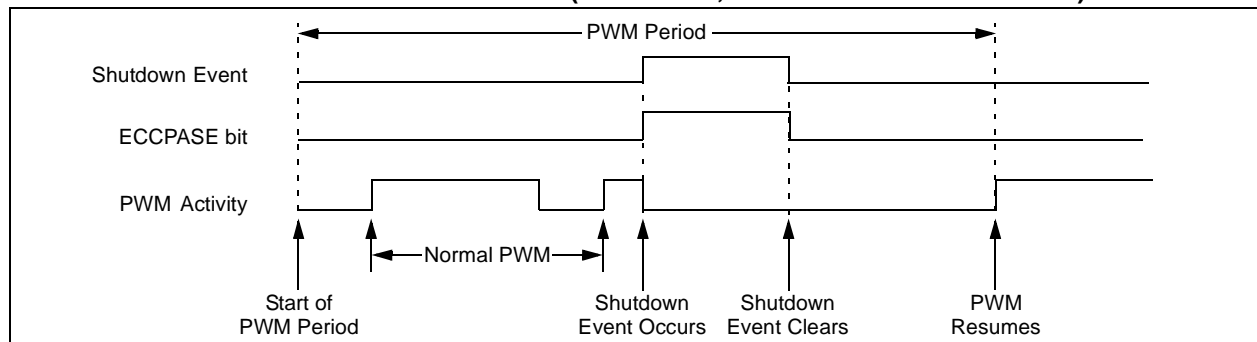
## 7.4.6 START-UP CONSIDERATIONS

When the ECCP module is used in the PWM mode, the application hardware must use the proper external pull-up and/or pull-down resistors on the PWM output pins. When the microcontroller is released from Reset, all of the I/O pins are in the high-impedance state. The external circuits must keep the power switch devices in the off state, until the microcontroller drives the I/O pins with the proper signal levels, or activates the PWM output(s).

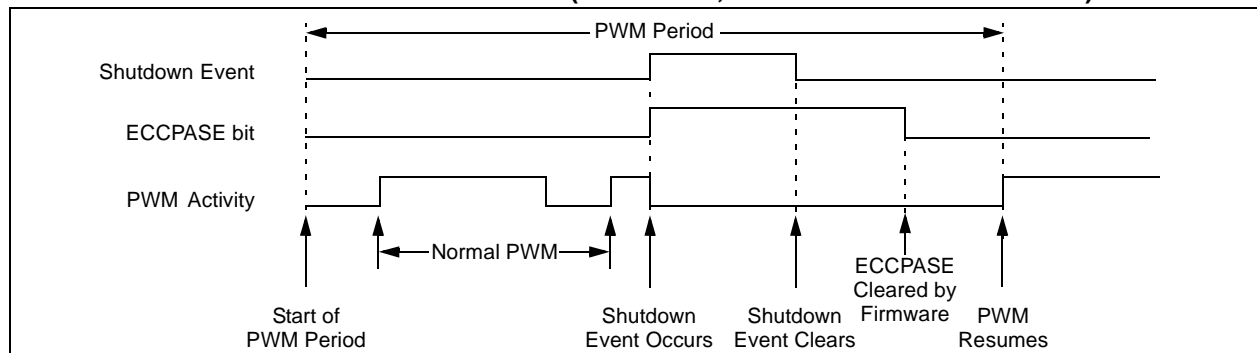
The CCP1M1:CCP1M0 bits (CCP1CON<1:0>) allow the user to choose whether the PWM output signals are active-high or active-low for each pair of PWM output pins (P1A/P1C and P1B/P1D). The PWM output polarities must be selected before the PWM pins are configured as outputs. Changing the polarity configuration while the PWM pins are configured as outputs is not recommended since it may result in damage to the application circuits.

The P1A, P1B, P1C and P1D output latches may not be in the proper states when the PWM module is initialized. Enabling the PWM pins for output at the same time as the ECCP module may cause damage to the application circuit. The ECCP module must be enabled in the proper Output mode and complete a full PWM cycle before configuring the PWM pins as outputs. The completion of a full PWM cycle is indicated by the TMR2IF bit being set as the second PWM period begins.

**FIGURE 7-15: PWM AUTO-SHUTDOWN (PRSEN = 1, AUTO-RESTART ENABLED)**



**FIGURE 7-16: PWM AUTO-SHUTDOWN (PRSEN = 0, AUTO-RESTART DISABLED)**



# PIC16F716

## 7.4.7 SETUP FOR PWM OPERATION

The following steps should be taken when configuring the ECCP module for PWM operation:

1. Configure the PWM pins P1A and P1B (and P1C and P1D, if used) as inputs by setting the corresponding TRISB bits.
2. Set the PWM period by loading the PR2 register.
3. Configure the ECCP module for the desired PWM mode and configuration by loading the CCP1CON register with the appropriate values:
  - Select one of the available output configurations and direction with the P1M1:P1M0 bits.
  - Select the polarities of the PWM output signals with the CCP1M3:CCP1M0 bits.
4. Set the PWM duty cycle by loading the CCPR1L register and CCP1CON<5:4> bits.
5. For Half-Bridge Output mode, set the dead-band delay by loading PWM1CON<6:0> with the appropriate value.
6. If auto-shutdown operation is required, load the ECCPAS register.
  - Select the auto-shutdown sources using the ECCPAS<2> AND ECCPAS<0> bits.
  - Select the shutdown states of the PWM output pins using PSSAC1:PSSAC0 and PSSBD1:PSSBD0 bits.
  - Set the ECCPASE bit (ECCPAS<7>).
7. If auto-restart operation is required, set the PRSEN bit (PWM1CON<7>).

## 8. Configure and start TMR2:

- Clear the TMR2 interrupt flag bit by clearing the TMR2IF bit (PIR1<1>).
  - Set the TMR2 prescale value by loading the T2CKPSx bits (T2CON<1:0>).
  - Enable Timer2 by setting the TMR2ON bit (T2CON<2>).
9. Enable PWM outputs after a new PWM cycle has started:
    - Wait until TMR2 overflows (TMR2IF bit is set).
    - Enable the CCP1/P1A, P1B, P1C and/or P1D pin outputs by clearing the respective TRISB bits.
    - Clear the ECCPASE bit (ECCPAS<7>).

See the previous section for additional details.

## 7.4.8 EFFECTS OF A RESET

Both Power-on and subsequent Resets will force all ports to Input mode and the ECCP registers to their Reset states.

This forces the Enhanced CCP module to reset to a state compatible with the standard ECCP module.

**TABLE 7-5: REGISTERS ASSOCIATED WITH ENHANCED PWM AND TIMER2**

Address	Name	Bit 7	Bit 6	Bit 5	Bit 4	Bit 3	Bit 2	Bit 1	Bit 0	Value on POR, BOR	Value on all other Resets
0Bh	INTCON	GIE	PEIE	TMR0IE	INT0IE	RBIE	TMR0IF	INT0IF	RBIF	0000 000x	0000 000u
0Ch	PIR1	—	ADIF	—	—	—	CCP1IF	TMR2IF	TMR1IF	-0-- -000	-0-- -000
8Ch	PIE1	—	ADIE	—	—	—	CCP1IE	TMR2IE	TMR1IE	-0-- --00	-0-- --00
11h	TMR2	Timer2 Module Register								0000 0000	0000 0000
92h	PR2	Timer2 Module Period Register								1111 1111	1111 1111
12h	T2CON	—	TOUTPS3	TOUTPS2	TOUTPS1	TOUTPS0	TMR2ON	T2CKPS1	T2CKPS0	-000 0000	-000 0000
86h	TRISB	PORTB Data Direction Register								1111 1111	1111 1111
16h	CCPR1H	Enhanced Capture/Compare/PWM Register1 High Byte								xxxx xxxx	uuuu uuuu
15h	CCPR1L	Enhanced Capture/Compare/PWM Register1 Low Byte								xxxx xxxx	uuuu uuuu
17h	CCP1CON	P1M1	P1M0	DC1B1	DC1B0	CCP1M3	CCP1M2	CCP1M1	CCP1M0	0000 0000	0000 0000
19h	ECCPAS	ECCPASE	ECCPAS2	—	ECCPAS0	PSSAC1	PSSAC0	PSSBD1	PSSBD0	00-0 0000	00-0 0000
18h	PWM1CON	PRSEN	PDC6	PDC5	PDC4	PDC3	PDC2	PDC1	PDC0	0000 0000	0000 0000

**Legend:** x = unknown, u = unchanged, - = unimplemented, read as '0'. Shaded cells are not used by the ECCP module in enhanced PWM mode.

## 8.0 ANALOG-TO-DIGITAL CONVERTER (A/D) MODULE

The Analog-to-Digital (A/D) Converter module has four inputs.

The A/D allows conversion of an analog input signal to a corresponding 8-bit digital number (refer to Application Note AN546 for use of A/D Converter). The output of the sample and hold is the input into the converter, which generates the result via successive approximation. The analog reference voltage is software selectable to either the device's positive supply voltage (VDD) or the voltage level on the RA3/AN3/VREF pin.

The A/D converter has a unique feature of being able to operate while the device is in Sleep mode. To operate in Sleep, the A/D conversion clock must be derived from the A/D's internal RC oscillator.

Additional information on the A/D module is available in the PICmicro® Mid-Range Reference Manual, (DS33023).

The A/D module has three registers. These registers are:

- A/D Result Register (ADRES)
- A/D Control Register 0 (ADCON0)
- A/D Control Register 1 (ADCON1)

A device Reset forces all registers to their Reset state. This forces the A/D module to be turned off and any conversion is aborted.

The ADCON0 register, shown in Register 8-1, controls the operation of the A/D module. The ADCON1 register, shown in Register 8-2, configures the functions of the port pins. The port pins can be configured as analog inputs (RA3 can also be a voltage reference) or as digital I/O.

### REGISTER 8-1: ADCON0 REGISTER (ADDRESS: 1Fh)

R/W-0	R/W-0	R/W-0	R/W-0	R/W-0	R/W-0	R/W-0	R/W-0
ADCS1	ADCS0	CHS2	CHS1	CHS0	GO/DONE	—	ADON
						bit 7	bit 0

- bit 7-6 **ADCS1:ADCS0:** A/D Conversion Clock Select bits  
 00 = FOSC/2  
 01 = FOSC/8  
 10 = FOSC/32  
 11 = FRC (Clock derived from the internal ADC RC oscillator)
- bit 5-3 **CHS2:CHS0:** Analog Channel Select bits  
 000 = channel 0, (RA0/AN0)  
 001 = channel 1, (RA1/AN1)  
 010 = channel 2, (RA2/AN2)  
 011 = channel 3, (RA3/AN3)  
 1xx = reserved, do not use
- bit 2 **GO/DONE:** A/D Conversion Status bit  
 If ADON = 1  
 1 = A/D conversion in progress (Setting this bit starts the A/D conversion)  
 0 = A/D conversion not in progress (This bit is automatically cleared by hardware when the A/D conversion is complete)
- bit 1 **Reserved:** Maintain this bit as '0'
- bit 0 **ADON:** A/D On bit  
 1 = A/D converter module is operating  
 0 = A/D converter module is shutoff and consumes no operating current

<b>Legend:</b>			
R = Readable bit	W = Writable bit	U = Unimplemented bit, read as '0'	
-n = Value at POR	'1' = Bit is set	'0' = Bit is cleared	x = Bit is unknown

# PIC16F716

## REGISTER 8-2: ADCON1 REGISTER (ADDRESS: 9Fh)

U-0	U-0	U-0	U-0	U-0	R/W-0	R/W-0	R/W-0
—	—	—	—	—	PCFG2	PCFG1	PCFG0
bit 7					bit 0		

bit 7-3 **Unimplemented:** Read as '0'

bit 2-0 **PCFG2:PCFG0:** A/D Port Configuration Control bits

PCFG2:PCFG0	AN3 RA3	AN2 RA2	AN1 RA1	AN0 RA0	VREF
0x0	A	A	A	A	VDD
0x1	VREF	A	A	A	RA3
100	A	D	A	A	VDD
101	VREF	D	A	A	RA3
11x	D	D	D	D	VDD

**Legend:** A = Analog input, D = Digital I/O

**Legend:**

R = Readable bit      W = Writable bit      U = Unimplemented bit, read as '0'  
 -n = Value at POR      '1' = Bit is set      '0' = Bit is cleared      x = Bit is unknown

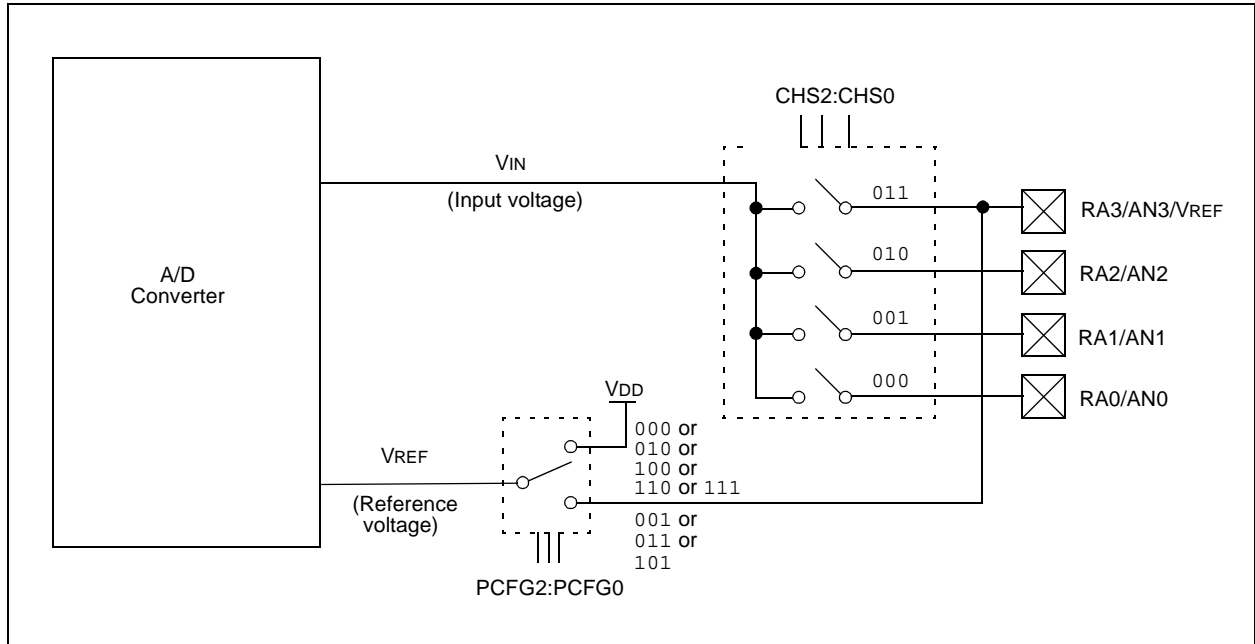
The ADRES register contains the result of the A/D conversion. When the A/D conversion is complete, the result is loaded into the ADRES register, the GO/DONE bit (ADCON0<2>) is cleared and the A/D interrupt flag bit ADIF is set. The block diagram of the A/D module is shown in Figure 8-1.

The value that is in the ADRES register is not modified for any Reset. The ADRES register will contain unknown data after a Power-on Reset.

After the A/D module has been configured as desired, the selected channel must be acquired before the conversion is started. The analog input channels must have their corresponding TRIS bits selected as an input. To determine acquisition time, see **Section 8.1 "A/D Acquisition Requirements"**. After this acquisition time has elapsed, the A/D conversion can be started. The following steps should be followed for doing an A/D conversion:

1. Configure the A/D module:
  - Configure analog pins/voltage reference/ and digital I/O (ADCON1)
  - Select A/D input channel (ADCON0)
  - Select A/D conversion clock (ADCON0)
  - Turn on A/D module (ADCON0)
2. Configure A/D interrupt (if desired):
  - Clear ADIF bit
  - Set ADIE bit
  - Set GIE bit
3. Wait the required acquisition time.
4. Start conversion:
  - Set GO/DONE bit (ADCON0)
5. Wait for A/D conversion to complete, by either:
  - Polling for the GO/DONE bit to be cleared
 OR
  - Waiting for the A/D interrupt
6. Read A/D Result register (ADRES), clear bit ADIF if required.
7. For the next conversion, go to step 1 or step 2 as required. The A/D conversion time per bit is defined as TAD. A minimum wait of 2TAD is required before next acquisition starts.

**FIGURE 8-1: A/D BLOCK DIAGRAM**



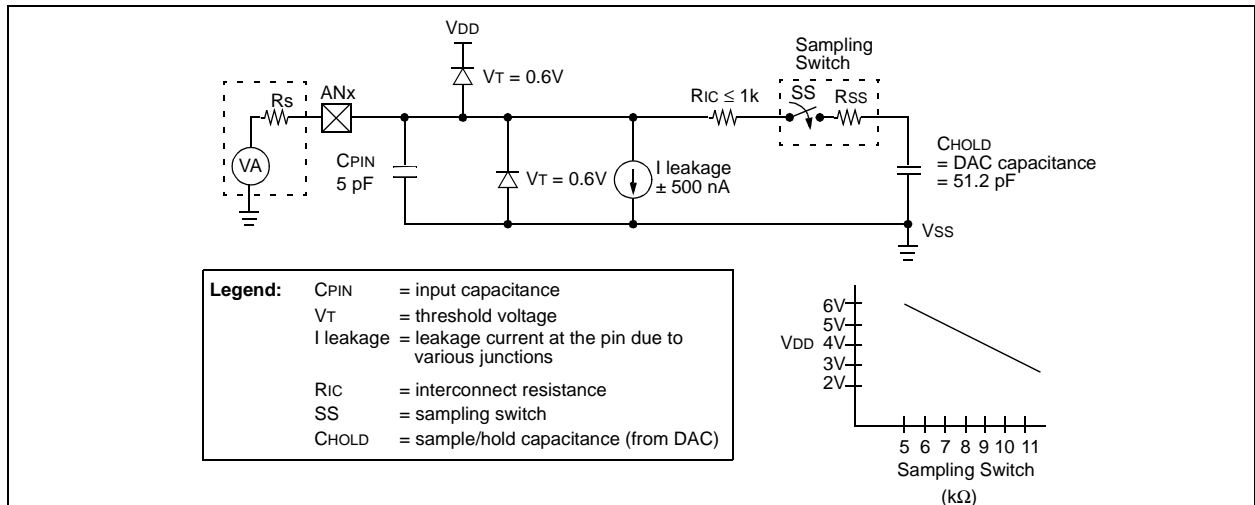
## 8.1 A/D Acquisition Requirements

For the A/D converter to meet its specified accuracy, the charge holding capacitor (CHOLD) must be allowed to fully charge to the input channel voltage level. The analog input model is shown in Figure 8-2. The source impedance ( $R_s$ ) and the internal sampling switch ( $R_{ss}$ ) impedance directly affect the time required to charge the capacitor CHOLD. The sampling switch ( $R_{ss}$ ) impedance varies over the device voltage ( $V_{DD}$ ). The source impedance affects the offset voltage at the analog input (due to pin leakage current). The maximum recommended impedance for analog sources is 10 k $\Omega$ . After the analog input channel is selected (changed) this acquisition must be done before the conversion can be started.

To calculate the minimum acquisition time,  $T_{ACQ}$ , see the PICmicro<sup>®</sup> Mid-Range Reference Manual, (DS33023). This equation calculates the acquisition time to within 1/2 LSB error. The 1/2 LSB error is the maximum error allowed for the A/D to meet its specified accuracy.

**Note:** When the conversion is started, the holding capacitor is disconnected from the input pin.

**FIGURE 8-2: ANALOG INPUT MODEL**



# PIC16F716

## 8.2 Selecting the A/D Conversion Clock

The A/D conversion time per bit is defined as TAD. The A/D conversion requires 9.5 TAD per 8-bit conversion. The source of the A/D conversion clock is software selectable. The four possible options for TAD are:

- 2 TOSC
- 8 TOSC
- 32 TOSC
- Internal RC oscillator

For correct A/D conversions, the A/D conversion clock (TAD) must be selected to ensure a minimum TAD time of 1.6  $\mu$ s.

Table 8-1 shows the resultant TAD times derived from the device operating frequencies and the A/D clock source selected.

## 8.3 Configuring Analog Port Pins

The ADCON1 and TRISA registers control the operation of the A/D port pins. The port pins that are desired as analog inputs must have their corresponding TRIS bits set (input). If the TRIS bit is cleared (output), the digital output level (VOH or VOL) will be converted.

The A/D operation is independent of the state of the CHS2:CHS0 bits and the TRIS bits.

**Note 1:** When reading the port register, all pins configured as analog input channels will read as cleared (a low level). Pins configured as digital inputs, will convert an analog input. Analog levels on a digitally configured input will not affect the conversion accuracy.

- 2:** Analog levels on any pin that is defined as a digital input (including the AN3:AN0 pins), may cause the input buffer to consume current that is out of the devices specification.

**TABLE 8-1: TAD vs. DEVICE OPERATING FREQUENCIES**

AD Clock Source (TAD)		Device Frequency			
Operation	ADCS1:ADCS0	20 MHz	5 MHz	1.25 MHz	333.33 kHz
2 TOSC	00	100 ns <sup>(2)</sup>	400 ns <sup>(2)</sup>	1.6 $\mu$ s	6 $\mu$ s
8 TOSC	01	400 ns <sup>(2)</sup>	1.6 $\mu$ s	6.4 $\mu$ s	24 $\mu$ s <sup>(3)</sup>
32 TOSC	10	1.6 $\mu$ s	6.4 $\mu$ s	25.6 $\mu$ s <sup>(3)</sup>	96 $\mu$ s <sup>(3)</sup>
RC	11	2-6 $\mu$ s <sup>(1), (4)</sup>	2-6 $\mu$ s <sup>(1), (4)</sup>	2-6 $\mu$ s <sup>(1), (4)</sup>	2-6 $\mu$ s <sup>(1)</sup>

Legend: Shaded cells are outside of recommended range.

- Note 1:** The RC source has a typical TAD time of 4  $\mu$ s.
- 2:** These values violate the minimum required TAD time.
- 3:** For faster conversion times, the selection of another clock source is recommended.
- 4:** When device frequency is greater than 1 MHz, the RC A/D conversion clock source is recommended for Sleep operation only.

## 8.4 A/D Conversions

**Note:** The  $\overline{GO/DONE}$  bit should **NOT** be set in the same instruction that turns on the A/D.

## 8.5 Use of the ECCP Trigger

An A/D conversion can be started by the “special event trigger” of the ECCP module. This requires that the CCP1M3:CCP1M0 bits (CCP1CON<3:0>) be programmed as ‘1011’ and that the A/D module is enabled (ADON bit is set). When the trigger occurs, the  $\overline{GO/DONE}$  bit will be set, starting the A/D conversion, and the Timer1 counter will be reset to zero. Timer1 is reset to automatically repeat the A/D acquisition period with minimal software overhead (moving the ADRES to the desired location). The appropriate analog input channel must be selected and the minimum acquisition done before the “special event trigger” sets the  $\overline{GO/DONE}$  bit (starts a conversion).

If the A/D module is not enabled (ADON is cleared), then the “special event trigger” will be ignored by the A/D module, but will still reset the Timer1 counter.

**TABLE 8-2: SUMMARY OF A/D REGISTERS**

Address	Name	Bit 7	Bit 6	Bit 5	Bit 4	Bit 3	Bit 2	Bit 1	Bit 0	Value on POR, BOR	Value on all other Resets	
05h	PORTA	—	—	— <sup>(1)</sup>	RA4	RA3	RA2	RA1	RA0	--xx 0000	--uu uuuu	
0Bh,8Bh	INTCON	GIE	PEIE	TOIE	INTE	RBIE	TOIF	INTF	RBFIF	0000 000x	0000 000u	
0Ch	PIR1	—	ADIF	—	—	—	CCP1IF	TMR2IF	TMR1IF	-0-- -000	-0-- -000	
1Eh	ADRES	A/D Result Register								xxxx xxxx	uuuu uuuu	
1Fh	ADCON0	ADCS1	ADCS0	CHS2	CHS1	CHS0	$\overline{GO/DONE}$	— <sup>(1)</sup>	ADON	0000 0000	0000 0000	
85h	TRISA	—	—	— <sup>(1)</sup>	PORTA Data Direction Register						--11 1111	--11 1111
8Ch	PIE1	—	ADIE	—	—	—	CCP1IE	TMR2IE	TMR1IE	-0-- -000	-0-- 0000	
9Fh	ADCON1	—	—	—	—	—	PCFG2	PCFG1	PCFG0	---- -000	---- -000	

**Legend:** x = unknown, u = unchanged, - = unimplemented read as ‘0’. Shaded cells are not used for A/D conversion.

**Note 1:** Reserved bit, do not use.

# PIC16F716

---

NOTES:



## 9.0 SPECIAL FEATURES OF THE CPU

The PIC16F716 device has a host of features intended to maximize system reliability, minimize cost through elimination of external components, provide power saving operating modes and offer code protection. These are:

- OSC Selection
- Reset
  - Power-on Reset (POR)
  - Power-up Timer (PWRT)
  - Oscillator Start-up Timer (OST)
  - Brown-out Reset (BOR)
- Interrupts
- Watchdog Timer (WDT)
- Sleep
- Code protection
- ID locations
- In-Circuit Serial Programming™ (ICSP™)

The PIC16F716 device has a Watchdog Timer, which can be shut off only through configuration bits. It runs off its own RC oscillator for added reliability. There are two timers that offer necessary delays on power-up. One is the Oscillator Start-up Timer (OST), intended to keep the chip in Reset until the crystal oscillator is stable. The other is the Power-up Timer (PWRT), which provides a fixed delay on power-up only and is designed to keep the part in Reset while the power supply stabilizes. With these two timers on-chip, most applications need no external Reset circuitry.

Sleep mode is designed to offer a very low current Power-down mode. The user can wake-up from Sleep through external Reset, Watchdog Timer Wake-up, or through an interrupt. Several oscillator options are also made available to allow the part to fit the application. The RC oscillator option saves system cost, while the LP crystal option saves power. A set of configuration bits are used to select various options.

Additional information on special features is available in the PICmicro® Mid-Range Reference Manual, (DS33023).

## 9.1 Configuration Bits

The configuration bits can be programmed (read as '0') or left unprogrammed (read as '1') to select various device configurations. These bits are mapped in program memory location 2007h.

The user will note that address 2007h is beyond the user program memory space. In fact, it belongs to the special configuration memory space (2000h – 3FFFh), which can be accessed only during programming.

# PIC16F716

## REGISTER 9-1: CONFIGURATION WORD

$\overline{\text{CP}}$	—	—	—	—	—	BORV	BOREN	—	—	$\overline{\text{PWRT}}\overline{\text{E}}$	WDTE	FOSC1	FOSC0
bit 13													bit 0

bit 13  **$\overline{\text{CP}}$** : Flash Program Memory Code Protection bit  
 1 = Code protection off  
 0 = All program memory code protected

bit 12-8 **Unimplemented**: Read as '1'

bit 7 **BORV**: Brown-out Reset Voltage bit  
 1 = VBOR set to 4.0V  
 0 = VBOR set to 2.5V

bit 6 **BOREN**: Brown-out Reset Enable bit<sup>(1)</sup>  
 1 = BOR enabled  
 0 = BOR disabled

bit 5-4 **Unimplemented**: Read as '1'

bit 3  **$\overline{\text{PWRT}}\overline{\text{E}}$** : Power-up Timer Enable bit <sup>(1)</sup>  
 1 = PWRT disabled  
 0 = PWRT enabled

bit 2 **WDTE**: Watchdog Timer Enable bit  
 1 = WDT enabled  
 0 = WDT disabled

bit 1-0 **FOSC1:FOSC0**: Oscillator Selection bits  
 11 = RC oscillator  
 10 = HS oscillator  
 01 = XT oscillator  
 00 = LP oscillator

**Note 1:** Enabling Brown-out Reset does not automatically enable Power-up Timer ( $\overline{\text{PWRT}}\overline{\text{E}}$ ).

### Legend:

R = Readable bit  
 -n = Value at POR

W = Writable bit  
 '1' = bit is set

U = Unimplemented bit, read as '0'  
 '0' = bit is cleared

x = bit is unknown

## 9.2 Oscillator Configurations

### 9.2.1 OSCILLATOR TYPES

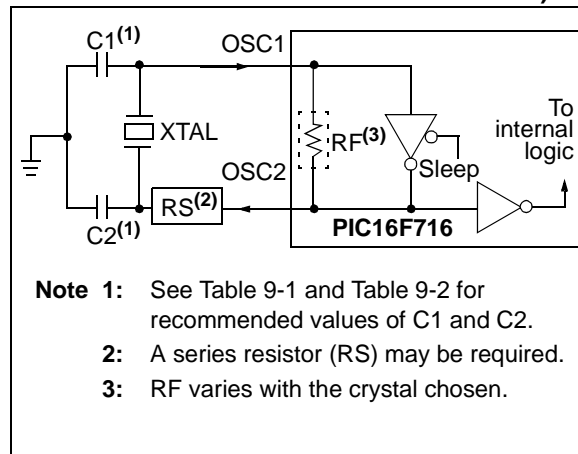
The PIC16F716 can be operated in four different oscillator modes. The user can program two configuration bits (FOSC1 and FOSC0) to select one of these four modes:

- LP - Low-power Crystal
- XT - Crystal/Resonator
- HS - High-speed Crystal/Resonator
- RC - Resistor/Capacitor

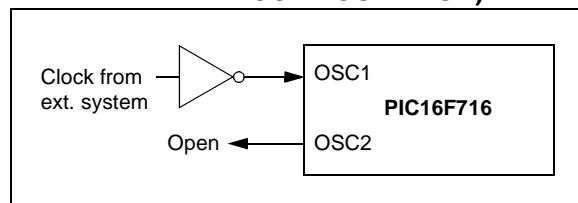
### 9.2.2 CRYSTAL OSCILLATOR/CERAMIC RESONATORS

In XT, LP or HS modes, a crystal or ceramic resonator is connected to the OSC1/CLKIN and OSC2/CLKOUT pins to establish oscillation (Figure 9-1). The PIC16F716 oscillator design requires the use of a parallel cut crystal. Use of a series cut crystal may give a frequency out of the crystal manufacturers specifications. When in XT, LP or HS modes, the device can have an external clock source to drive the OSC1/CLKIN pin (Figure 9-2).

**FIGURE 9-1: CRYSTAL/CERAMIC RESONATOR OPERATION (HS, XT OR LP OSC CONFIGURATION)**



**FIGURE 9-2: EXTERNAL CLOCK INPUT OPERATION (HS, XT OR LP OSC CONFIGURATION)**



**TABLE 9-1: CERAMIC RESONATORS**

Ranges Tested:			
Mode	Freq	OSC1 (C1)	OSC2 (C2)
XT	455 kHz	68-100 pF	68-100 pF
	2.0 MHz	15-68 pF	15-68 pF
HS	4.0 MHz	10-68 pF	10-68 pF
	8.0 MHz	15-68 pF	15-68 pF
	16.0 MHz	10-22 pF	10-22 pF

**Note 1:** These values are for design guidance only. See notes at bottom of page.

**TABLE 9-2: CAPACITOR SELECTION FOR CRYSTAL OSCILLATOR**

Osc Type	Crystal Freq	Cap. Range C1	Cap. Range C2
LP	32 kHz	15-33 pF	15-33 pF
	200 kHz	5-10 pF	5-10 pF
XT	200 kHz	47-68 pF	47-68 pF
	1 MHz	15-33 pF	15-33 pF
	4 MHz	15-33 pF	15-33 pF
HS	4 MHz	15-33 pF	15-33 pF
	8 MHz	15-33 pF	15-33 pF
	20 MHz	15-33 pF	15-33 pF

**Note 1:** These values are for design guidance only. See notes at bottom of page.

**Note 1:** Higher capacitance increases the stability of the oscillator, but also increases the start-up time.

**2:** Since each resonator/crystal has its own characteristics, the user should consult the resonator/crystal manufacturer for appropriate values of external components.

**3:** RS may be required to avoid overdriving crystals with low drive level specification.

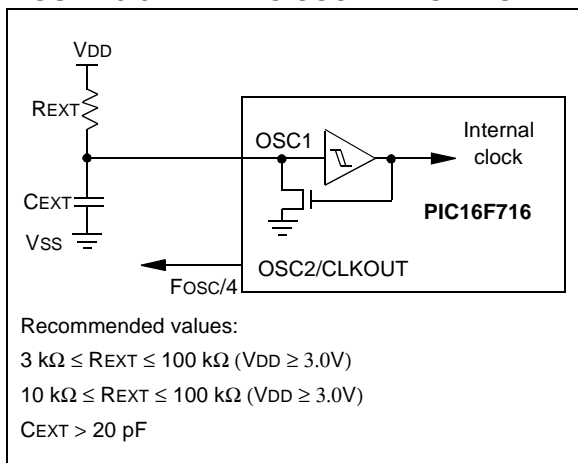
**4:** When using an external clock for the OSC1 input, loading of the OSC2 pin must be kept to a minimum by leaving the OSC2 pin unconnected.

# PIC16F716

## 9.2.3 RC OSCILLATOR

For timing insensitive applications, the “RC” device option offers additional cost savings. The RC oscillator frequency is a function of the supply voltage, the resistor (R<sub>EXT</sub>) and capacitor (C<sub>EXT</sub>) values and the operating temperature. In addition to this, the oscillator frequency will vary from unit to unit due to normal process parameter variation. Furthermore, the difference in lead frame capacitance between package types will also affect the oscillation frequency, especially for low C<sub>EXT</sub> values. The user also needs to take into account variation due to tolerance of external R and C components used. Figure 9-3 shows how the R/C combination is connected to the PIC16F716.

**FIGURE 9-3: RC OSCILLATOR MODE**



## 9.3 Reset

The PIC16F716 differentiates between various kinds of Reset:

- Power-on Reset (POR)
- $\overline{\text{MCLR}}$  Reset during normal operation
- $\overline{\text{MCLR}}$  Reset during Sleep
- WDT Reset (during normal operation)
- WDT Wake-up (during Sleep)
- Brown-out Reset (BOR)

Some registers are not affected in any Reset condition; their status is unknown on POR and unchanged in any other Reset. Most other registers are reset to a “Reset state” on Power-on Reset (POR), on the  $\overline{\text{MCLR}}$  and WDT Reset, on  $\overline{\text{MCLR}}$  Reset during Sleep and Brown-out Reset (BOR). They are not affected by a WDT Wake-up, which is viewed as the resumption of normal operation. The  $\overline{\text{TO}}$  and  $\overline{\text{PD}}$  bits are set or cleared differently in different Reset situations as indicated in Table 9-4. These bits are used in software to determine the nature of the Reset. See Table 9-6 for a full description of Reset states of all registers.

A simplified block diagram of the On-chip Reset circuit is shown in Figure 9-5.

The PICmicro<sup>®</sup> microcontrollers have an  $\overline{\text{MCLR}}$  noise filter in the  $\overline{\text{MCLR}}$  Reset path. The filter will detect and ignore small pulses.

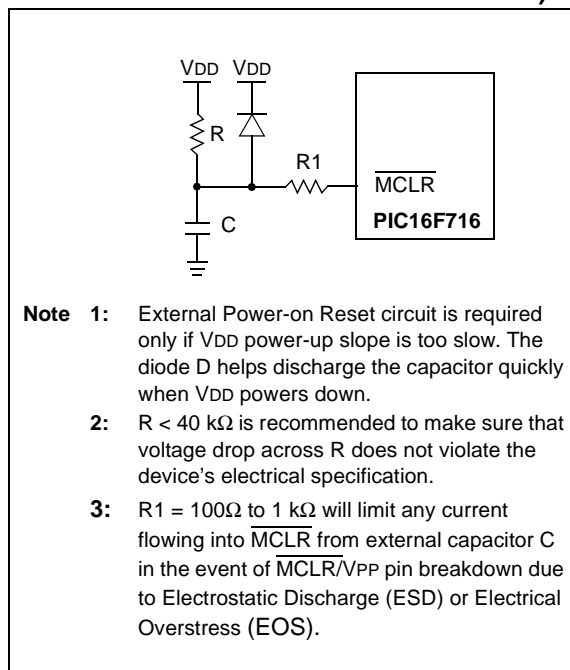
It should be noted that a WDT Reset does not drive the  $\overline{\text{MCLR}}$  pin low.

## 9.4 Power-On Reset (POR)

A Power-on Reset pulse is generated on-chip when V<sub>DD</sub> rise is detected. To take advantage of the POR, just tie the  $\overline{\text{MCLR}}$  pin directly (or through a resistor) to V<sub>DD</sub>. This will eliminate external RC components usually needed to create a Power-on Reset. A maximum rise time for V<sub>DD</sub> is specified (parameter D004). For a slow rise time, see Figure 9-4.

When the device starts normal operation (exits the Reset condition), device operating parameters (voltage, frequency, temperature,...) must be met to ensure operation. If these conditions are not met, the device must be held in Reset until the operating conditions are met. Brown-out Reset may be used to meet the start-up conditions.

**FIGURE 9-4: EXTERNAL POWER-ON RESET CIRCUIT (FOR SLOW V<sub>DD</sub> POWER-UP)**



## 9.5 Power-up Timer (PWRT)

The Power-up Timer provides a fixed nominal time-out, on power-up only, from the POR. The Power-up Timer operates on an internal RC oscillator. The chip is kept in Reset as long as the PWRT is active. The PWRT's time delay allows VDD to rise to an acceptable level. The power-up timer enable configuration bit,  $\overline{\text{PWRTTE}}$ , is provided to enable/disable the PWRT.

The power-up time delay will vary from chip-to-chip due to VDD, temperature and process variation. See AC parameters for details.

## 9.6 Oscillator Start-up Timer (OST)

The Oscillator Start-up Timer (OST) provides a 1024 oscillator cycle (from OSC1 input) delay after the PWRT delay is over. This ensures that the crystal oscillator or resonator has started and stabilized. See AC parameters for details.

The OST time-out is invoked only for XT, LP and HS modes and only on Power-on Reset or wake-up from Sleep.

## 9.7 Programmable Brown-Out Reset (PBOR)

The PIC16F716 has on-chip Brown-out Reset circuitry. A configuration bit, BOREN, can disable (if clear/programmed) or enable (if set) the Brown-out Reset circuitry.

The BORV configuration bit selects the programmable Brown-out Reset threshold voltage (VBOR). When BORV is 1, VBOR is 4.0V. When BORV is 0, VBOR is 2.5V.

A Brown-out Reset occurs when VDD falls below VBOR for a time greater than parameter TBOR (see Table 12-4). A Brown-out Reset is not guaranteed to occur if VDD falls below VBOR for less than parameter TBOR.

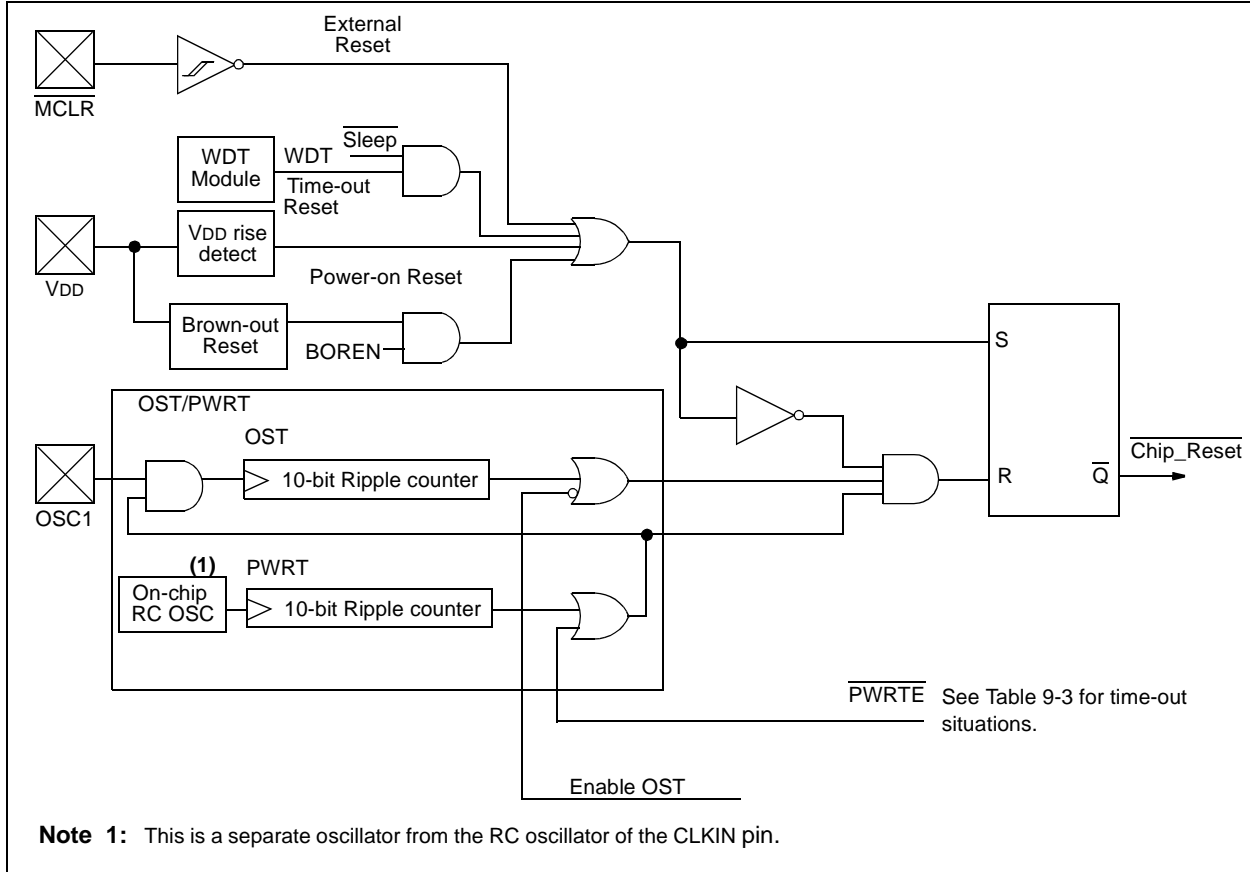
On any Reset (Power-on, Brown-out, Watchdog, etc.) the chip will remain in Reset until VDD rises above VBOR. The Power-up Timer will be invoked and will keep the chip in Reset an additional 72 ms only if the Power-up Timer enable bit in the configuration register is set to 0 ( $\overline{\text{PWRTTE}} = 0$ ).

If the Power-up Timer is enabled and VDD drops below VBOR while the Power-up Timer is running, the chip will go back into a Brown-out Reset and the Power-up Timer will be re-initialized. Once VDD rises above VBOR, the Power-up Timer will execute a 72 ms Reset. See Figure 9-6.

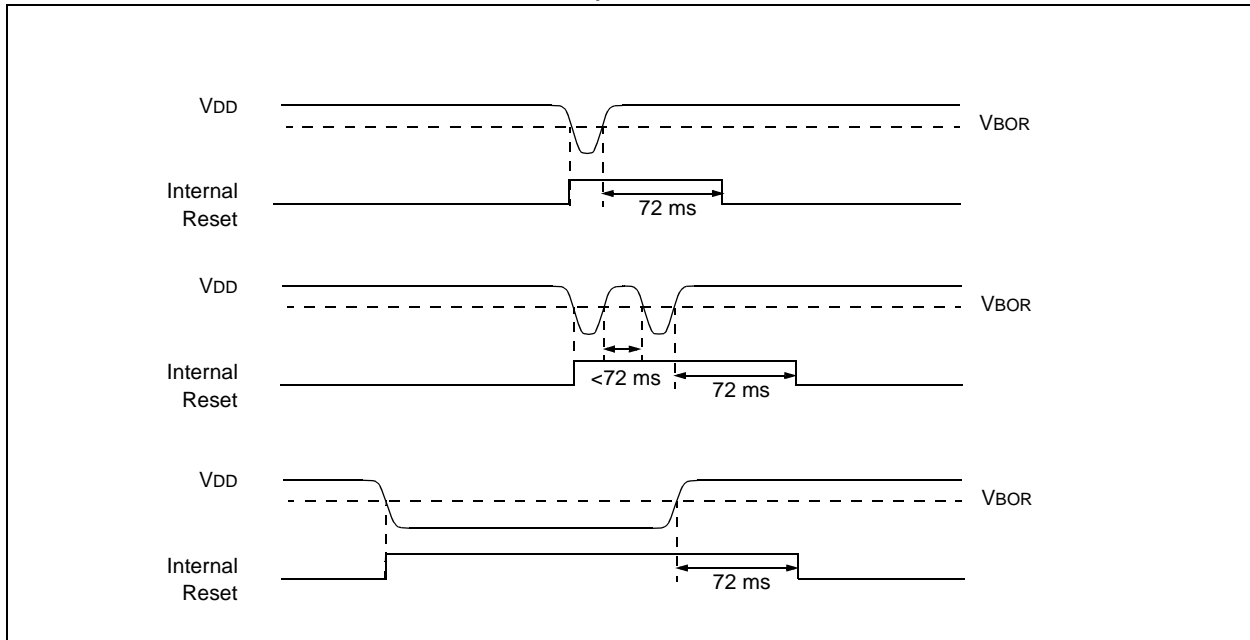
For operations where the desired brown-out voltage is other than 4.0V or 2.5V, an external brown-out circuit must be used. Figure 9-8, Figure 9-9 and Figure 9-10 show examples of external Brown-out Protection circuits.

# PIC16F716

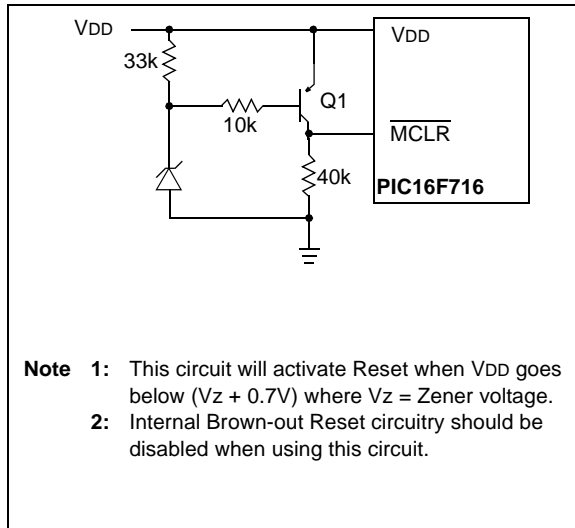
**FIGURE 9-5: SIMPLIFIED BLOCK DIAGRAM OF ON-CHIP RESET CIRCUIT**



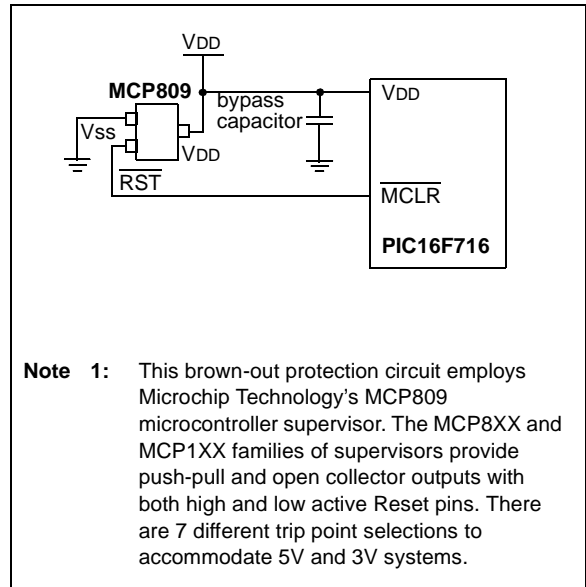
**FIGURE 9-6: BROWN-OUT SITUATIONS ( $\overline{\text{PWRTE}} = 0$ )**



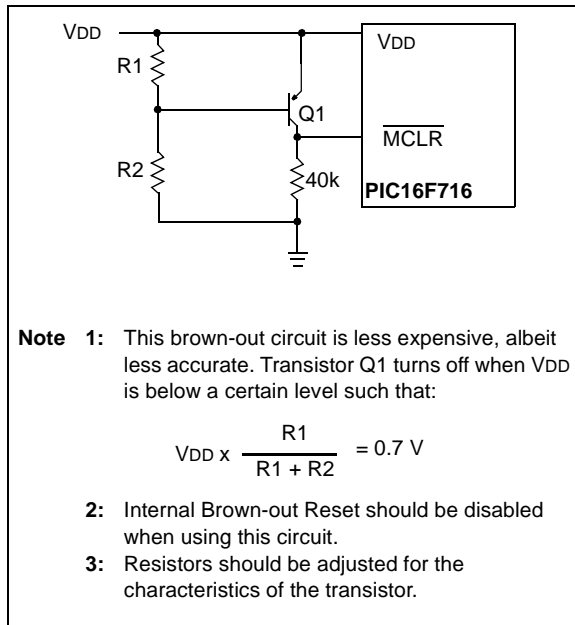
**FIGURE 9-7: EXTERNAL BROWN-OUT PROTECTION CIRCUIT 1**



**FIGURE 9-9: EXTERNAL BROWN-OUT PROTECTION CIRCUIT 3**



**FIGURE 9-8: EXTERNAL BROWN-OUT PROTECTION CIRCUIT 2**



# PIC16F716

## 9.8 Time-out Sequence

On power-up, the time-out sequence is as follows: First PWRT time-out is invoked after the POR time delay has expired. Then OST is activated. The total time-out will vary based on oscillator configuration and the status of the PWRT. For example, in RC mode with the PWRT disabled, there will be no time-out at all. Figure 9-10, Figure 9-11, and Figure 9-12 depict time-out sequences on power-up.

Since the time-outs occur from the POR pulse, if  $\overline{\text{MCLR}}$  is kept low long enough, the time-outs will expire. Then bringing  $\overline{\text{MCLR}}$  high will begin execution immediately (Figure 9-12). This is useful for testing purposes or to synchronize more than one PIC16F716 device operating in parallel.

Table 9-5 shows the Reset conditions for some special function registers, while Table 9-6 shows the Reset conditions for all the registers.

**TABLE 9-3: TIME-OUT IN VARIOUS SITUATIONS**

Oscillator Configuration	Power-up or Brown-out		Wake-up from Sleep
	$\overline{\text{PWRT}} = 0$	$\overline{\text{PWRT}} = 1$	
XT, HS, LP	72 ms + 1024 Tosc	1024 Tosc	1024 Tosc
RC	72 ms	—	—

**TABLE 9-4: STATUS BITS AND THEIR SIGNIFICANCE**

POR	BOR	TO	PD	
0	x	1	1	Power-on Reset (BOREN = 0)
0	1	1	1	Power-on Reset (BOREN = 1)
0	x	0	x	Illegal, $\overline{\text{TO}}$ is set on $\overline{\text{POR}}$
0	x	x	0	Illegal, $\overline{\text{PD}}$ is set on $\overline{\text{POR}}$
1	0	1	1	Brown-out Reset
1	1	0	1	WDT Reset
1	1	0	0	WDT Wake-up
1	1	u	u	$\overline{\text{MCLR}}$ Reset during normal operation
1	1	1	0	$\overline{\text{MCLR}}$ Reset during Sleep or interrupt wake-up from Sleep

## 9.9 Power Control/Status Register (PCON)

The Power Control/Status Register, PCON has two bits.

Bit 0 is the Brown-out Reset Status bit,  $\overline{\text{BOR}}$ . If the BOREN configuration bit is set,  $\overline{\text{BOR}}$  is '1' on Power-on Reset and reset to '0' when a Brown-out condition occurs.  $\overline{\text{BOR}}$  must then be set by the user and checked on subsequent resets to see if it is clear, indicating that another Brown-out has occurred.

If the BOREN configuration bit is clear,  $\overline{\text{BOR}}$  is unknown on Power-on Reset.

Bit 1 is  $\overline{\text{POR}}$  (Power-on Reset Status bit). It is cleared on a Power-on Reset and unaffected otherwise. The user must set this bit following a Power-on Reset.



**TABLE 9-5: RESET CONDITION FOR SPECIAL REGISTERS**

Condition	Program Counter	Status Register	PCON Register
Power-on Reset (BOREN = 0)	000h	0001 1xxx	---- --0x
Power-on Reset (BOREN = 1)	000h	0001 1xxx	---- --01
$\overline{\text{MCLR}}$ Reset during normal operation	000h	000u uuuu	---- --uu
$\overline{\text{MCLR}}$ Reset during Sleep	000h	0001 0uuu	---- --uu
WDT Reset	000h	0000 1uuu	---- --uu
WDT Wake-up	PC + 1	uuu0 0uuu	---- --uu
Brown-out Reset	000h	0001 1uuu	---- --u0
Interrupt wake-up from Sleep	PC + 1 <sup>(1)</sup>	uuu1 0uuu	---- --uu

**Legend:** u = unchanged, x = unknown, - = unimplemented bit read as '0'.

**Note 1:** When the wake-up is due to an interrupt and the GIE bit is set, the PC is loaded with the interrupt vector (0004h).

# PIC16F716

**TABLE 9-6: INITIALIZATION CONDITIONS FOR ALL REGISTERS OF THE PIC16F716**

Register	Power-on Reset, Brown-out Reset	MCLR Resets WDT Reset	Wake-up via WDT or Interrupt
W	xxxx xxxx	uuuu uuuu	uuuu uuuu
INDF	N/A	N/A	N/A
TMR0	xxxx xxxx	uuuu uuuu	uuuu uuuu
PCL	0000h	0000h	PC + 1 <sup>(2)</sup>
STATUS	0001 1xxx	000q quuu <sup>(3)</sup>	uuuq quuu <sup>(3)</sup>
FSR	xxxx xxxx	uuuu uuuu	uuuu uuuu
PORTA <sup>(4), (5), (6)</sup>	--xx 0000	--xx 0000	--uu uuuu
PORTB <sup>(4), (5)</sup>	xxxx xxxx	uuuu uuuu	uuuu uuuu
PCLATH	---0 0000	---0 0000	---u uuuu
INTCON	0000 -00x	0000 -00u	uuuu -uuu <sup>(1)</sup>
PIR1	-0-- -000	-0-- -000	-u-- -uuu <sup>(1)</sup>
TMR1L	xxxx xxxx	uuuu uuuu	uuuu uuuu
TMR1H	xxxx xxxx	uuuu uuuu	uuuu uuuu
T1CON	--00 0000	--uu uuuu	--uu uuuu
TMR2	0000 0000	0000 0000	uuuu uuuu
T2CON	-000 0000	-000 0000	-uuu uuuu
CCPR1L	xxxx xxxx	uuuu uuuu	uuuu uuuu
CCPR1H	xxxx xxxx	uuuu uuuu	uuuu uuuu
CCP1CON	0000 0000	0000 0000	uuuu uuuu
PWM1CON	0000 0000	0000 0000	uuuu uuuu
ECCPAS	00-0 0000	00-0 0000	u-uu uuuu
ADRES	xxxx xxxx	uuuu uuuu	uuuu uuuu
ADCON0	0000 0000	0000 0000	uuuu uuuu
OPTION_REG	1111 1111	1111 1111	uuuu uuuu
TRISA	--11 1111	--11 1111	--uu uuuu
TRISB	1111 1111	1111 1111	uuuu uuuu
PIE1	-0-- -000	-0-- -000	-u-- -uuu
PCON	---- -qqr	---- -uu	---- -uu
PR2	1111 1111	1111 1111	uuuu uuuu
ADCON1	---- -000	---- -000	---- -uuu

**Legend:** u = unchanged, x = unknown, - = unimplemented bit, read as '0', q = value depends on condition

**Note 1:** One or more bits in INTCON and/or PIR1 will be affected (to cause wake-up).

**2:** When the wake-up is due to an interrupt and the GIE bit is set, the PC is loaded with the interrupt vector (0004h).

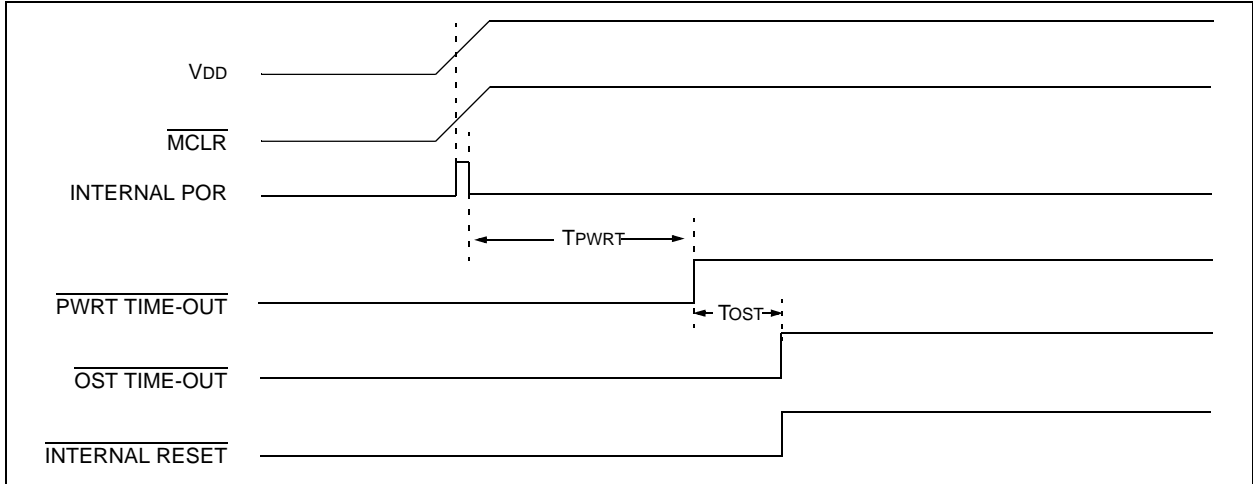
**3:** See Table 9-5 for Reset value for specific condition.

**4:** On any device Reset, these pins are configured as inputs.

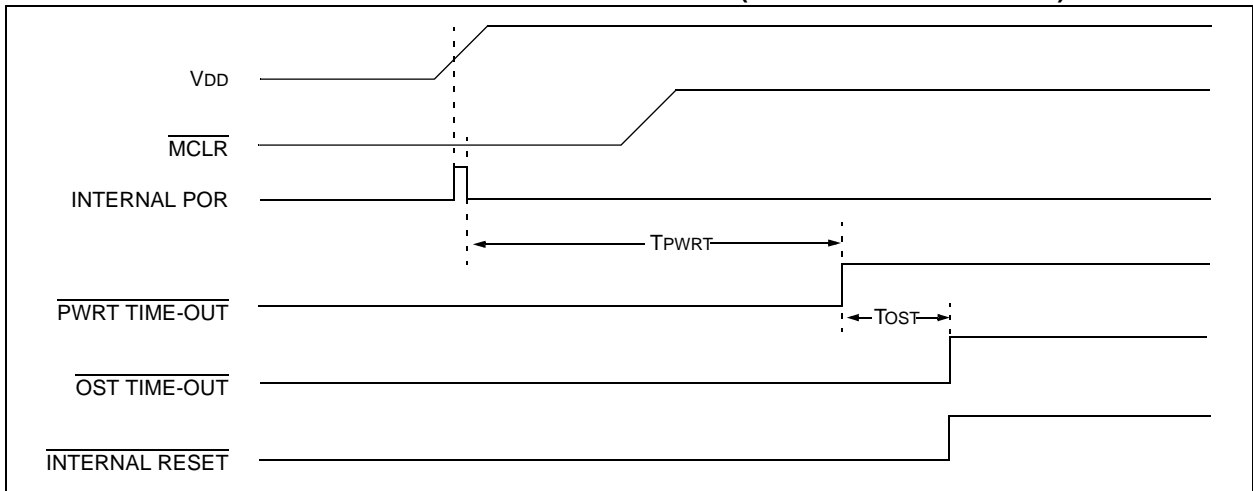
**5:** This is the value that will be in the port output latch.

**6:** Output latches are unknown or unchanged. Analog inputs default to analog and read '0'.

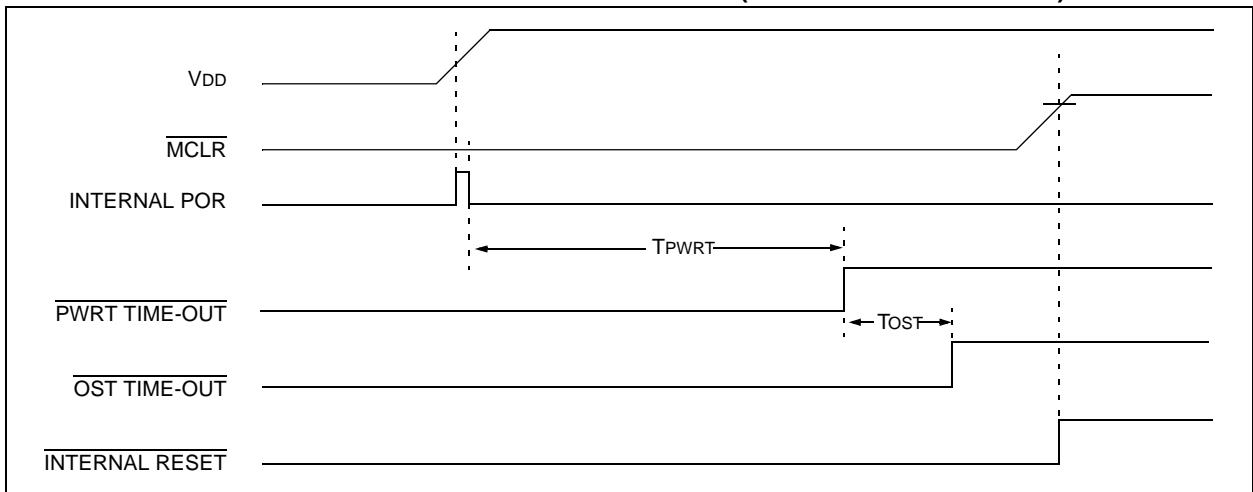
**FIGURE 9-10: TIME-OUT SEQUENCE ON POWER-UP ( $\overline{\text{MCLR}}$  TIED TO  $V_{DD}$ )**



**FIGURE 9-11: TIME-OUT SEQUENCE ON POWER-UP ( $\overline{\text{MCLR}}$  NOT TIED TO  $V_{DD}$ ): CASE 1**



**FIGURE 9-12: TIME-OUT SEQUENCE ON POWER-UP ( $\overline{\text{MCLR}}$  NOT TIED TO  $V_{DD}$ ): CASE 2**



# PIC16F716

## 9.10 Interrupts

The PIC16F716 devices have up to 7 sources of interrupt. The Interrupt Control Register (INTCON) records individual interrupt requests in flag bits. It also has individual and global interrupt enable bits.

**Note:** Individual interrupt flag bits are set regardless of the status of their corresponding mask bit or the GIE bit.

A Global Interrupt Enable bit, GIE (INTCON<7>) enables all un-masked interrupts when set, or disables all interrupts when cleared. When bit GIE is enabled, and an interrupt's flag bit and mask bit are set, the interrupt will vector immediately. Individual interrupts can be disabled through their corresponding enable bits in various registers. Individual interrupt bits are set, regardless of the status of the GIE bit. The GIE bit is cleared on Reset and when an interrupt vector occurs.

The "return-from-interrupt" instruction, `RETFIE`, exits the interrupt routine, as well as sets the GIE bit, which re-enables interrupts.

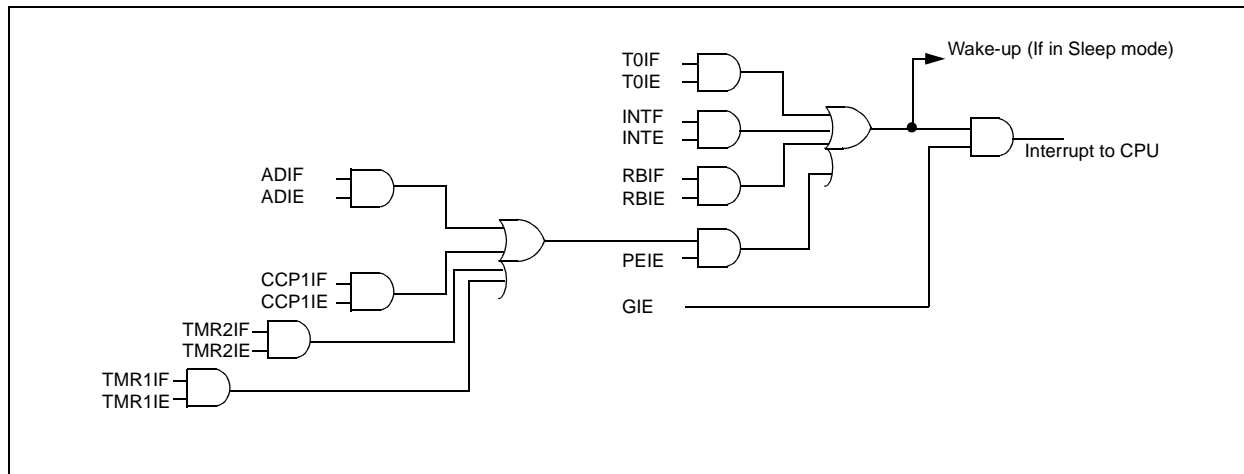
The RB0/INT pin interrupt, the RB port change interrupt and the TMR0 overflow interrupt flags are contained in the INTCON register.

The peripheral interrupt flags are contained in the special function registers, PIR1 and PIR2. The corresponding interrupt enable bits are contained in special function registers, PIE1 and PIE2, and the peripheral interrupt enable bit is contained in special function register, INTCON.

When an interrupt is responded to, the GIE bit is cleared to disable any further interrupt, the return address is pushed onto the stack and the PC is loaded with 0004h. Once in the interrupt service routine, the source(s) of the interrupt can be determined by polling the interrupt flag bits. The interrupt flag bit(s) must be cleared in software before re-enabling interrupts to avoid recursive interrupts.

For external interrupt events, such as the INT pin or PORTB change interrupt, the interrupt latency will be three or four instruction cycles. The exact latency depends when the interrupt event occurs. The latency is the same for one or two-cycle instructions. Individual interrupt flag bits are set, regardless of the status of their corresponding mask bit or the GIE bit.

FIGURE 9-13: INTERRUPT LOGIC



## 9.10.1 INT INTERRUPT

External interrupt on RB0/INT pin is edge triggered, either rising if bit INTEDG (OPTION\_REG<6>) is set, or falling if the INTEDG bit is clear. When a valid edge appears on the RB0/INT pin, flag bit INTF (INTCON<1>) is set. This interrupt can be disabled by clearing enable bit INTE (INTCON<4>). Flag bit INTF must be cleared in software in the interrupt service routine before re-enabling this interrupt. The INT interrupt can wake-up the processor from Sleep, if bit INTE was set prior to going into Sleep. The status of global interrupt enable bit GIE decides whether or not the processor branches to the interrupt vector following wake-up. See **Section 9.13 “Power-down Mode (Sleep)”** for details on Sleep mode.

## 9.10.2 TMR0 INTERRUPT

An overflow (FFh → 00h) in the TMR0 register will set flag bit TOIF (INTCON<2>). The interrupt can be enabled/disabled by setting/clearing enable bit TOIE (INTCON<5>). (**Section 4.0 “Timer0 Module”**).

## 9.10.3 PORTB INTCON CHANGE

An input change on PORTB<7:4> sets flag bit RBIF (INTCON<0>). The interrupt can be enabled/disabled by setting/clearing enable bit RBIE (INTCON<4>). (**Section 3.2 “PORTB and the TRISB Register”**).

## 9.11 Context Saving During Interrupts

During an interrupt, only the return PC value is saved on the stack. Typically, users may wish to save key registers during an interrupt, (i.e., W register and Status register). This will have to be implemented in firmware.

Example 9-1 stores and restores the W, Status, PCLATH and FSR registers. Context storage registers, W\_TEMP, STATUS\_TEMP, PCLATH\_TEMP and FSR\_TEMP, must be defined in Common RAM which are those addresses between 70h-7Fh in Bank 0 and between F0h-FFh in Bank 1.

The example:

- a) Stores the W register.
- b) Stores the Status register in Bank 0.
- c) Stores the PCLATH register
- d) Stores the FSR register.
- e) Executes the interrupt service routine code (User-generated).
- f) Restores all saved registers in reverse order from which they were stored

### EXAMPLE 9-1: SAVING STATUS, W, AND PCLATH REGISTERS IN RAM

```

MOVWF    W_TEMP           ;Copy W to TEMP register, could be bank one or zero
SWAPF    STATUS,W         ;Swap status to be saved into W
MOVWF    STATUS_TEMP      ;Save status to bank zero STATUS_TEMP register
MOVF     PCLATH, W        ;Only required if using pages 1, 2 and/or 3
MOVWF    PCLATH_TEMP      ;Save PCLATH into W
CLRF     PCLATH           ;Page zero, regardless of current page
BCF      STATUS, IRP      ;Return to Bank 0
MOVF     FSR, W           ;Copy FSR to W
MOVWF    FSR_TEMP        ;Copy FSR from W to FSR_TEMP
:
:(ISR)
:
MOVF     FSR_TEMP,W       ;Restore FSR
MOVWF    FSR              ;Move W into FSR
MOVF     PCLATH_TEMP, W   ;Restore PCLATH
MOVWF    PCLATH           ;Move W into PCLATH
SWAPF    STATUS_TEMP,W    ;Swap STATUS_TEMP register into W
MOVWF    STATUS           ;Move W into STATUS register
SWAPF    W_TEMP,F        ;Swap W_TEMP
SWAPF    W_TEMP,W        ;Swap W_TEMP into W
RETFIE                          ;Return from interrupt and enable GIE

```

# PIC16F716

## 9.12 Watchdog Timer (WDT)

The Watchdog Timer is a free running, on-chip, RC oscillator which does not require any external components. This RC oscillator is separate from the RC oscillator of the OSC1/CLKIN pin. That means that the WDT will run, even if the clock on the OSC1/CLKIN and OSC2/CLKOUT pins of the device have been stopped, for example, by execution of a `SLEEP` instruction.

During normal operation, a WDT time-out generates a device Reset (Watchdog Timer Reset). If the device is in Sleep mode, a WDT time-out causes the device to wake-up and continue with normal operation (Watchdog Timer Wake-up). The  $\overline{TO}$  bit in the Status register will be cleared upon a Watchdog Timer time-out.

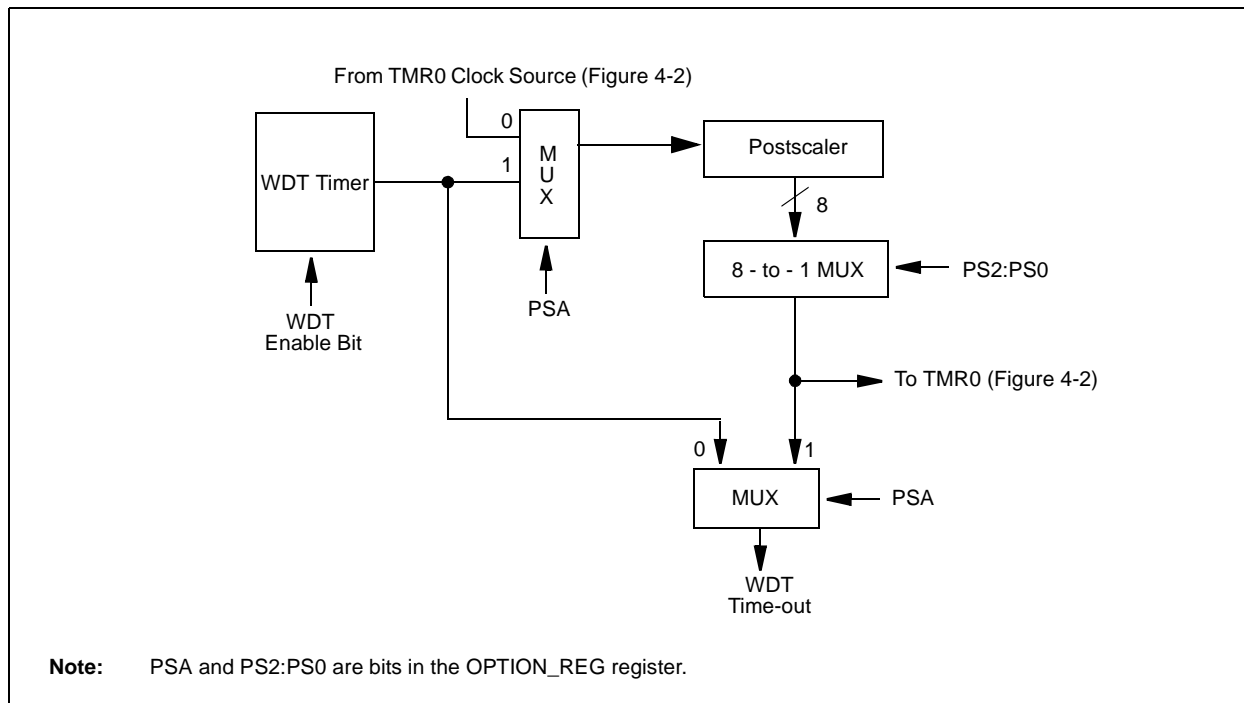
The WDT can be permanently disabled by clearing configuration bit `WDTE` (Section 9.1 “Configuration Bits”).

WDT time-out period values may be found in the Electrical Specifications section under `TWDT` (parameter #31). Values for the WDT prescaler (actually a postscaler, but shared with the Timer0 prescaler) may be assigned using the `OPTION_REG` register.

**Note:** The `CLRWDT` and `SLEEP` instructions clear the WDT and the postscaler, if assigned to the WDT, and prevent it from timing out and generating a device Reset condition.

**Note:** When a `CLRWDT` instruction is executed and the prescaler is assigned to the WDT, the prescaler count will be cleared, but the prescaler assignment is not changed.

**FIGURE 9-14: WATCHDOG TIMER BLOCK DIAGRAM**



**FIGURE 9-15: SUMMARY OF WATCHDOG TIMER REGISTERS**

Address	Name	Bits 13:8	Bit 7	Bit 6	Bit 5	Bit 4	Bit 3	Bit 2	Bit 1	Bit 0
2007h	Config. bits	(1)	BORV <sup>(1)</sup>	BOREN <sup>(1)</sup>	—	—	$\overline{PWRTE}$ <sup>(1)</sup>	WDTE	FOSC1	FOSC0
81h	OPTION_REG	N/A	$\overline{RBPU}$	INTEDG	T0CS	T0SE	PSA	PS2	PS1	PS0

**Legend:** Shaded cells are not used by the Watchdog Timer.

**Note 1:** See Register 9-1 for operation of these bits.

## 9.13 Power-down Mode (Sleep)

Power-down mode is entered by executing a `SLEEP` instruction.

If enabled, the Watchdog Timer will be cleared but keeps running, the  $\overline{PD}$  bit (STATUS<3>) is cleared, the  $\overline{TO}$  (STATUS<4>) bit is set, and the oscillator driver is turned off. The I/O ports maintain the status they had, before the `SLEEP` instruction was executed (driving high, low or high-impedance).

For lowest current consumption in this mode, place all I/O pins at either  $V_{DD}$  or  $V_{SS}$ , ensure no external circuitry is drawing current from the I/O pin, power-down the A/D and the disable external clocks. Pull all I/O pins that are hi-impedance inputs, high or low externally, to avoid switching currents caused by floating inputs. The `TOCKI` input should also be at  $V_{DD}$  or  $V_{SS}$  for lowest current consumption. The contribution from on-chip pull-ups on `PORTB` should be considered.

The  $\overline{MCLR}$  pin must be at a logic high level (parameter D042).

### 9.13.1 WAKE-UP FROM SLEEP

The device can wake-up from Sleep through one of the following events:

1. External Reset input on  $\overline{MCLR}$  pin.
2. Watchdog Timer Wake-up (if WDT was enabled).
3. Interrupt from INT pin, RB port change or some peripheral interrupts.

External  $\overline{MCLR}$  Reset will cause a device Reset. All other events are considered a continuation of program execution and cause a “wake-up”. The  $\overline{TO}$  and  $\overline{PD}$  bits in the Status register can be used to determine the cause of device Reset. The  $\overline{PD}$  bit, which is set on power-up, is cleared when Sleep is invoked. The  $\overline{TO}$  bit is cleared if a WDT time-out occurred (and caused wake-up).

The following peripheral interrupts can wake the device from Sleep:

1. TMR1 interrupt. Timer1 must be operating as an asynchronous counter.
2. ECCP capture mode interrupt.
3. ADC running in ADRC mode.

Other peripherals cannot generate interrupts, since during Sleep, no on-chip clocks are present.

When the `SLEEP` instruction is being executed, the next instruction (`PC + 1`) is pre-fetched. For the device to wake-up through an interrupt event, the corresponding interrupt enable bit must be set (enabled). Wake-up is regardless of the state of the GIE bit. If the GIE bit is clear (disabled), the device continues execution at the instruction after the `SLEEP` instruction. If the GIE bit is set (enabled), the device executes the instruction after the `SLEEP` instruction and then branches to the interrupt address (0004h). In cases where the execution of the instruction following `SLEEP` is not desirable, the user should have a `NOP` after the `SLEEP` instruction.

### 9.13.2 WAKE-UP USING INTERRUPTS

When global interrupts are disabled (GIE cleared) and any interrupt source has both its interrupt enable bit and interrupt flag bit set, one of the following will occur:

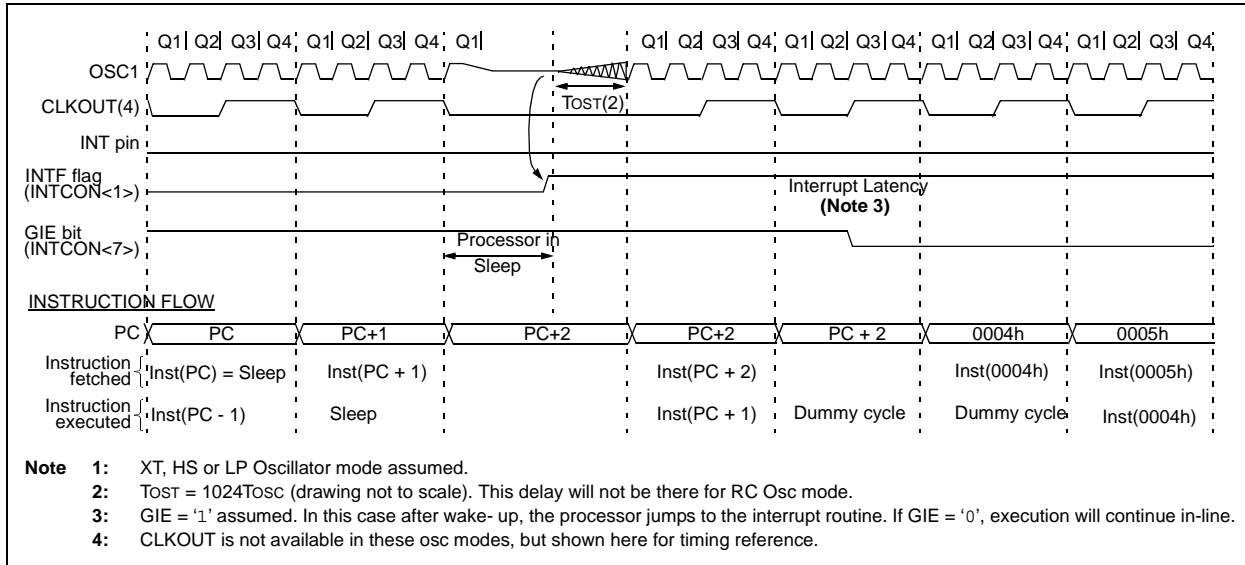
- If the interrupt occurs **before** the execution of a `SLEEP` instruction, the `SLEEP` instruction will complete as a `NOP`. Therefore, the WDT and WDT postscaler will not be cleared, the  $\overline{TO}$  bit will not be set and  $\overline{PD}$  bits will not be cleared.
- If the interrupt occurs **during or after** the execution of a `SLEEP` instruction, the device will immediately wake-up from Sleep. The `SLEEP` instruction will be completely executed before the wake-up. Therefore, the WDT and WDT postscaler will be cleared, the  $\overline{TO}$  bit will be set and the  $\overline{PD}$  bit will be cleared.

Even if the flag bits were checked before executing a `SLEEP` instruction, it may be possible for flag bits to become set before the `SLEEP` instruction completes. To determine whether a `SLEEP` instruction executed, test the  $\overline{PD}$  bit. If the  $\overline{PD}$  bit is set, the `SLEEP` instruction was executed as a `NOP`.

To ensure that the WDT is cleared, a `CLRWDT` instruction should be executed before a `SLEEP` instruction.

# PIC16F716

**FIGURE 9-16: WAKE-UP FROM SLEEP THROUGH INTERRUPT**



## 9.14 Program Verification/Code Protection

If the code protection bit has not been programmed, the on-chip program memory can be read out for verification purposes.

## 9.15 ID Locations

Four memory locations (2000h - 2003h) are designated as ID locations where the user can store checksum or other code-identification numbers. These locations are not accessible during normal execution, but are readable and writable during program/verify. It is recommended that only the 4 Least Significant bits of the ID location are used.

## 9.16 In-Circuit Serial Programming™

PIC16F716 microcontrollers can be serially programmed while in the end application circuit. This is simply done with two lines for clock and data, and three other lines for power, ground and the programming voltage. This allows customers to manufacture boards with unprogrammed devices and then program the microcontroller just before shipping the product. This also allows the most recent firmware or a custom firmware to be programmed.

For complete details on serial programming, please refer to the In-Circuit Serial Programming™ (ICSP™) Specification, (DS40245).



## 10.0 INSTRUCTION SET SUMMARY

Each PIC16F716 instruction is a 14-bit word divided into an opcode which specifies the instruction type and one or more operands which further specify the operation of the instruction. The PIC16F716 instruction set summary in Table 10-2 lists **byte-oriented**, **bit-oriented**, and **literal and control** operations. Table 10-1 shows the opcode field descriptions.

For **byte-oriented** instructions, 'f' represents a file register designator and 'd' represents a destination designator. The file register designator specifies which file register is to be used by the instruction.

The destination designator specifies where the result of the operation is to be placed. If 'd' is zero, the result is placed in the W register. If 'd' is one, the result is placed in the file register specified in the instruction.

For **bit-oriented** instructions, 'b' represents a bit field designator which selects the number of the bit affected by the operation, while 'f' represents the number of the file in which the bit is located.

For **literal and control** operations, 'k' represents an eight or eleven bit constant or literal value.

**TABLE 10-1: OPCODE FIELD DESCRIPTIONS**

Field	Description
f	Register file address (0x00 to 0x7F)
W	Working register (accumulator)
b	Bit address within an 8-bit file register
k	Literal field, constant data or label
x	Don't care location (= 0 or 1) The assembler will generate code with x = 0. It is the recommended form of use for compatibility with all Microchip software tools.
d	Destination select; d = 0: store result in W, d = 1: store result in file register f. Default is d = 1
label	Label name
TOS	Top of Stack
PC	Program Counter
PCLATH	Program Counter High Latch
GIE	Global Interrupt Enable bit
WDT	Watchdog Timer/Counter
TO	Time-out bit
PD	Power-down bit
dest	Destination either the W register or the specified register file location
[ ]	Options
( )	Contents
→	Assigned to
< >	Register bit field
∈	In the set of
<i>italics</i>	User defined term (font is courier)

The instruction set is highly orthogonal and is grouped into three basic categories:

- **Byte-oriented** operations
- **Bit-oriented** operations
- **Literal and control** operations

All instructions are executed within one single instruction cycle, unless a conditional test is true or the program counter is changed as a result of an instruction. In this case, the execution takes two instruction cycles with the second cycle executed as a NOP. One instruction cycle consists of four oscillator periods. Thus, for an oscillator frequency of 4 MHz, the normal instruction execution time is 1 μs. If a conditional test is true or the program counter is changed as a result of an instruction, the instruction execution time is 2 μs.

Table 10-2 lists the instructions recognized by the MPASM™ assembler.

Figure 10-1 shows the three general formats that the instructions can have.

**Note 1:** Any unused opcode is reserved. Use of any reserved opcode may cause unexpected operation.

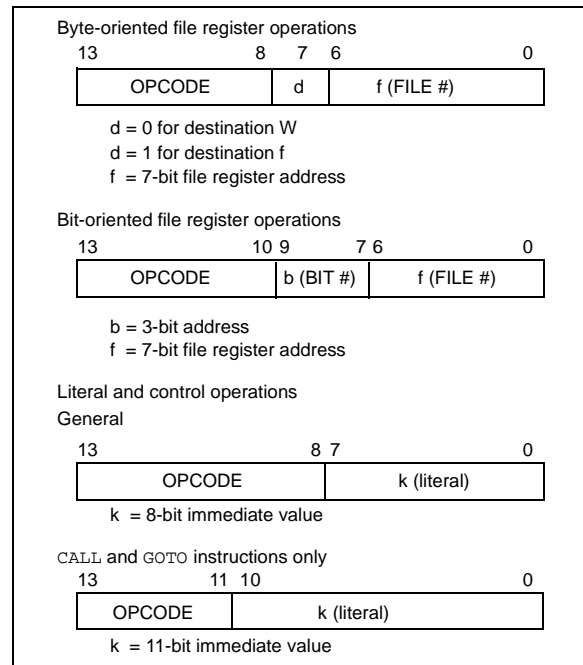
**2:** To maintain upward compatibility with future PICmicro products, do not use the OPTION and TRIS instructions.

All examples use the following format to represent a hexadecimal number:

0xhh

where h signifies a hexadecimal digit.

**FIGURE 10-1: GENERAL FORMAT FOR INSTRUCTIONS**



# PIC16F716

**TABLE 10-2: PIC16F716 INSTRUCTION SET**

Mnemonic, Operands	Description	Cycles	14-Bit Opcode				Status Affected	Notes	
			MSb			LSb			
<b>BYTE-ORIENTED FILE REGISTER OPERATIONS</b>									
ADDWF	f, d	Add W and f	1	00	0111	dfff	ffff	C,DC,Z	1,2
ANDWF	f, d	AND W with f	1	00	0101	dfff	ffff	Z	1,2
CLRF	f	Clear f	1	00	0001	1fff	ffff	Z	2
CLRWF	—	Clear W	1	00	0001	0xxx	xxxx	Z	
COMF	f, d	Complement f	1	00	1001	dfff	ffff	Z	1,2
DECf	f, d	Decrement f	1	00	0011	dfff	ffff	Z	1,2
DECFSZ	f, d	Decrement f, Skip if 0	1(2)	00	1011	dfff	ffff		1,2,3
INCF	f, d	Increment f	1	00	1010	dfff	ffff	Z	1,2
INCFSZ	f, d	Increment f, Skip if 0	1(2)	00	1111	dfff	ffff		1,2,3
IORWF	f, d	Inclusive OR W with f	1	00	0100	dfff	ffff	Z	1,2
MOVF	f, d	Move f	1	00	1000	dfff	ffff	Z	1,2
MOVWF	f	Move W to f	1	00	0000	1fff	ffff		
NOP	—	No Operation	1	00	0000	0xx0	0000		
RLF	f, d	Rotate Left f through Carry	1	00	1101	dfff	ffff	C	1,2
RRF	f, d	Rotate Right f through Carry	1	00	1100	dfff	ffff	C	1,2
SUBWF	f, d	Subtract W from f	1	00	0010	dfff	ffff	C,DC,Z	1,2
SWAPF	f, d	Swap nibbles in f	1	00	1110	dfff	ffff		1,2
XORWF	f, d	Exclusive OR W with f	1	00	0110	dfff	ffff	Z	1,2
<b>BIT-ORIENTED FILE REGISTER OPERATIONS</b>									
BCF	f, b	Bit Clear f	1	01	00bb	bfff	ffff		1,2
BSF	f, b	Bit Set f	1	01	01bb	bfff	ffff		1,2
BTFSC	f, b	Bit Test f, Skip if Clear	1(2)	01	10bb	bfff	ffff		3
BTFSS	f, b	Bit Test f, Skip if Set	1(2)	01	11bb	bfff	ffff		3
<b>LITERAL AND CONTROL OPERATIONS</b>									
ADDLW	k	Add literal and W	1	11	111x	kkkk	kkkk	C,DC,Z	
ANDLW	k	AND literal with W	1	11	1001	kkkk	kkkk	Z	
CALL	k	Call subroutine	2	10	0kkk	kkkk	kkkk		
CLRWDt	—	Clear Watchdog Timer	1	00	0000	0110	0100	$\overline{TO}, \overline{PD}$	
GOTO	k	Go to address	2	10	1kkk	kkkk	kkkk		
IORLW	k	Inclusive OR literal with W	1	11	1000	kkkk	kkkk	Z	
MOVLW	k	Move literal to W	1	11	00xx	kkkk	kkkk		
RETFIE	—	Return from interrupt	2	00	0000	0000	1001		
RETLW	k	Return with literal in W	2	11	01xx	kkkk	kkkk		
RETURN	—	Return from Subroutine	2	00	0000	0000	1000		
SLEEP	—	Go into Standby mode	1	00	0000	0110	0011	$\overline{TO}, \overline{PD}$	
SUBLW	k	Subtract W from literal	1	11	110x	kkkk	kkkk	C,DC,Z	
XORLW	k	Exclusive OR literal with W	1	11	1010	kkkk	kkkk	Z	

- Note 1:** When an I/O register is modified as a function of itself ( e.g., `MOVf PORTB, 1`), the value used will be that value present on the pins themselves. For example, if the data latch is '1' for a pin configured as input and is driven low by an external device, the data will be written back with a '0'.
- Note 2:** If this instruction is executed on the TMR0 register (and, where applicable, `d = 1`), the prescaler will be cleared if assigned to the Timer0 Module.
- Note 3:** If Program Counter (PC) is modified or a conditional test is true, the instruction requires two cycles. The second cycle is executed as a NOP.

## 10.1 Instruction Descriptions

### ADDLW Add Literal and W

Syntax:	[ <i>label</i> ] ADDLW k				
Operands:	$0 \leq k \leq 255$				
Operation:	$(W) + k \rightarrow (W)$				
Status Affected:	C, DC, Z				
Encoding:	<table border="1" style="display: inline-table; border-collapse: collapse;"><tr><td style="padding: 2px;">11</td><td style="padding: 2px;">111x</td><td style="padding: 2px;">kkkk</td><td style="padding: 2px;">kkkk</td></tr></table>	11	111x	kkkk	kkkk
11	111x	kkkk	kkkk		
Description:	The contents of the W register are added to the eight bit literal 'k' and the result is placed in the W register.				
Words:	1				
Cycles:	1				
Example	ADDLW 0x15 Before Instruction W = 0x10 After Instruction W = 0x25				

### ADDWF Add W and f

Syntax:	[ <i>label</i> ] ADDWF f,d				
Operands:	$0 \leq f \leq 127$ $d \in [0,1]$				
Operation:	$(W) + (f) \rightarrow (\text{dest})$				
Status Affected:	C, DC, Z				
Encoding:	<table border="1" style="display: inline-table; border-collapse: collapse;"><tr><td style="padding: 2px;">00</td><td style="padding: 2px;">0111</td><td style="padding: 2px;">dfff</td><td style="padding: 2px;">ffff</td></tr></table>	00	0111	dfff	ffff
00	0111	dfff	ffff		
Description:	Add the contents of the W register with register 'f'. If 'd' is 0 the result is stored in the W register. If 'd' is 1 the result is stored back in register 'f'.				
Words:	1				
Cycles:	1				
Example	ADDWF REG1, 0 Before Instruction W = 0x17 REG1 = 0xC2 After Instruction W = 0xD9 REG1 = 0xC2 Z = 0 C = 0 DC = 0				

### ANDLW AND Literal with W

Syntax:	[ <i>label</i> ] ANDLW k				
Operands:	$0 \leq k \leq 255$				
Operation:	$(W) .\text{AND}. (k) \rightarrow (W)$				
Status Affected:	Z				
Encoding:	<table border="1" style="display: inline-table; border-collapse: collapse;"><tr><td style="padding: 2px;">11</td><td style="padding: 2px;">1001</td><td style="padding: 2px;">kkkk</td><td style="padding: 2px;">kkkk</td></tr></table>	11	1001	kkkk	kkkk
11	1001	kkkk	kkkk		
Description:	The contents of W register are AND'ed with the eight bit literal 'k'. The result is placed in the W register.				
Words:	1				
Cycles:	1				
Example	ANDLW 0x5F Before Instruction W = 0xA3 After Instruction W = 0x03				

### ANDWF AND W with f

Syntax:	[ <i>label</i> ] ANDWF f,d				
Operands:	$0 \leq f \leq 127$ $d \in [0,1]$				
Operation:	$(W) .\text{AND}. (f) \rightarrow (\text{dest})$				
Status Affected:	Z				
Encoding:	<table border="1" style="display: inline-table; border-collapse: collapse;"><tr><td style="padding: 2px;">00</td><td style="padding: 2px;">0101</td><td style="padding: 2px;">dfff</td><td style="padding: 2px;">ffff</td></tr></table>	00	0101	dfff	ffff
00	0101	dfff	ffff		
Description:	AND the W register with register 'f'. If 'd' is 0 the result is stored in the W register. If 'd' is 1 the result is stored back in register 'f'.				
Words:	1				
Cycles:	1				
Example	ANDWF REG1, 1 Before Instruction W = 0x17 REG1 = 0xC2 After Instruction W = 0x17 REG1 = 0x02				

# PIC16F716

## BCF Bit Clear f

Syntax: `[label] BCF f,b`

Operands:  $0 \leq f \leq 127$   
 $0 \leq b \leq 7$

Operation:  $0 \rightarrow (f<b>)$

Status Affected: None

Encoding: 

01	00bb	bfff	ffff
----	------	------	------

Description: Bit 'b' in register 'f' is cleared.

Words: 1

Cycles: 1

Example `BCF REG1, 7`

Before Instruction  
`REG1 = 0xC7`

After Instruction  
`REG1 = 0x47`

## BSF Bit Set f

Syntax: `[label] BSF f,b`

Operands:  $0 \leq f \leq 127$   
 $0 \leq b \leq 7$

Operation:  $1 \rightarrow (f<b>)$

Status Affected: None

Encoding: 

01	01bb	bfff	ffff
----	------	------	------

Description: Bit 'b' in register 'f' is set.

Words: 1

Cycles: 1

Example `BSF REG1, 7`

Before Instruction  
`REG1 = 0x0A`

After Instruction  
`REG1 = 0x8A`

## BTFSC Bit Test f, Skip if Clear

Syntax: `[label] BTFSC f,b`

Operands:  $0 \leq f \leq 127$   
 $0 \leq b \leq 7$

Operation: skip if  $(f<b>) = 0$

Status Affected: None

Encoding: 

01	10bb	bfff	ffff
----	------	------	------

Description: If bit 'b' in register 'f' is '0' then the next instruction is skipped. If bit 'b' is '0' then the next instruction fetched during the current instruction execution is discarded, and a NOP is executed instead, making this a two-cycle instruction.

Words: 1

Cycles: 1(2)

Example

```

HERE    BTFSC    REG1
FALSE   GOTO    PROCESS_CODE
TRUE    .
        .
        .
    
```

Before Instruction  
`PC = address HERE`

After Instruction  
 if `REG<1> = 0,`  
`PC = address TRUE`  
 if `REG<1>=1,`  
`PC = address FALSE`

## BTFSS Bit Test f, Skip if Set

**Syntax:** [ *label* ] BTFSS *f*,*b*

**Operands:**  $0 \leq f \leq 127$   
 $0 \leq b < 7$

**Operation:** skip if (*f*<*b*>) = 1

**Status Affected:** None

**Encoding:**

01	11bb	bfff	ffff
----	------	------	------

**Description:** If bit 'b' in register 'f' is '1' then the next instruction is skipped. If bit 'b' is '1', then the next instruction fetched during the current instruction execution, is discarded and a NOP is executed instead, making this a two-cycle instruction.

**Words:** 1

**Cycles:** 1(2)

**Example**

```

HERE   BTFSS   REG1
FALSE  GOTO   PROCESS_CODE
TRUE   .
      .
      .

```

**Before Instruction**  
PC = address *HERE*

**After Instruction**  
if FLAG<1> = 0,  
PC = address *FALSE*  
if FLAG<1> = 1,  
PC = address *TRUE*

## CALL Call Subroutine

**Syntax:** [ *label* ] CALL *k*

**Operands:**  $0 \leq k \leq 2047$

**Operation:** (PC)+ 1 → TOS,  
*k* → PC<10:0>,  
(PCLATH<4:3>) → PC<12:11>

**Status Affected:** None

**Encoding:**

10	0kkk	kkkk	kkkk
----	------	------	------

**Description:** Call Subroutine. First, return address (PC+1) is pushed onto the stack. The eleven bit immediate address is loaded into PC bits <10:0>. The upper bits of the PC are loaded from PCLATH. CALL is a two-cycle instruction.

**Words:** 1

**Cycles:** 2

**Example**

```

HERE   CALL   THERE

```

**Before Instruction**  
PC = Address *HERE*

**After Instruction**  
PC = Address *THERE*  
TOS = Address *HERE+1*

## CLRF Clear f

**Syntax:** [ *label* ] CLRF *f*

**Operands:**  $0 \leq f \leq 127$

**Operation:** 00h → (*f*)  
1 → Z

**Status Affected:** Z

**Encoding:**

00	0001	1fff	ffff
----	------	------	------

**Description:** The contents of register 'f' are cleared and the Z bit is set.

**Words:** 1

**Cycles:** 1

**Example**

```

CLRF   REG1

```

**Before Instruction**  
REG1 = 0x5A

**After Instruction**  
REG1 = 0x00  
Z = 1

# PIC16F716

## CLRW Clear W

Syntax:	[ <i>label</i> ] CLRW				
Operands:	None				
Operation:	00h → (W) 1 → Z				
Status Affected:	Z				
Encoding:	<table border="1" style="display: inline-table; border-collapse: collapse;"><tr><td style="padding: 2px;">00</td><td style="padding: 2px;">0001</td><td style="padding: 2px;">0000</td><td style="padding: 2px;">0011</td></tr></table>	00	0001	0000	0011
00	0001	0000	0011		
Description:	W register is cleared. Zero bit (Z) is set.				
Words:	1				
Cycles:	1				
Example	<pre>CLRW Before Instruction     W = 0x5A After Instruction     W = 0x00     Z = 1</pre>				

## COMF Complement f

Syntax:	[ <i>label</i> ] COMF f,d				
Operands:	0 ≤ f ≤ 127 d ∈ [0,1]				
Operation:	( $\bar{f}$ ) → (dest)				
Status Affected:	Z				
Encoding:	<table border="1" style="display: inline-table; border-collapse: collapse;"><tr><td style="padding: 2px;">00</td><td style="padding: 2px;">1001</td><td style="padding: 2px;">dfff</td><td style="padding: 2px;">ffff</td></tr></table>	00	1001	dfff	ffff
00	1001	dfff	ffff		
Description:	The contents of register 'f' are complemented. If 'd' is 0 the result is stored in W. If 'd' is 1 the result is stored back in register 'f'.				
Words:	1				
Cycles:	1				
Example	<pre>COMF    REG1, 0 Before Instruction     REG1 = 0x13 After Instruction     REG1 = 0x13     W    = 0xEC</pre>				

## CLRWDTClear Watchdog Timer

Syntax:	[ <i>label</i> ] CLRWDTClear Watchdog Timer				
Operands:	None				
Operation:	00h → WDT 0 → WDT prescaler, 1 → $\overline{TO}$ 1 → $\overline{PD}$				
Status Affected:	$\overline{TO}$ , $\overline{PD}$				
Encoding:	<table border="1" style="display: inline-table; border-collapse: collapse;"><tr><td style="padding: 2px;">00</td><td style="padding: 2px;">0000</td><td style="padding: 2px;">0110</td><td style="padding: 2px;">0100</td></tr></table>	00	0000	0110	0100
00	0000	0110	0100		
Description:	CLRWDTClear Watchdog Timer. It also resets the prescaler of the WDT. Status bits $\overline{TO}$ and $\overline{PD}$ are set.				
Words:	1				
Cycles:	1				
Example	<pre>CLRWDTClear Watchdog Timer Before Instruction     WDT counter = ? After Instruction     WDT counter = 0x00     WDT prescaler = 0     <math>\overline{TO}</math> = 1     <math>\overline{PD}</math> = 1</pre>				

## DECF Decrement f

Syntax:	[ <i>label</i> ] DECF f,d				
Operands:	0 ≤ f ≤ 127 d ∈ [0,1]				
Operation:	(f) - 1 → (dest)				
Status Affected:	Z				
Encoding:	<table border="1" style="display: inline-table; border-collapse: collapse;"><tr><td style="padding: 2px;">00</td><td style="padding: 2px;">0011</td><td style="padding: 2px;">dfff</td><td style="padding: 2px;">ffff</td></tr></table>	00	0011	dfff	ffff
00	0011	dfff	ffff		
Description:	Decrement register 'f'. If 'd' is 0 the result is stored in the W register. If 'd' is 1 the result is stored back in register 'f'.				
Words:	1				
Cycles:	1				
Example	<pre>DECF    CNT, 1 Before Instruction     CNT = 0x01     Z   = 0 After Instruction     CNT = 0x00     Z   = 1</pre>				

**DECFSZ**      **Decrement f, Skip if 0**

---

Syntax:      [ *label* ] DECFSZ f,d

Operands:     $0 \leq f \leq 127$   
 $d \in [0,1]$

Operation:     $(f) - 1 \rightarrow (\text{dest});$     skip if result = 0

Status Affected:    None

Encoding:    

00	1011	dfff	ffff
----	------	------	------

Description:    The contents of register 'f' are decremented. If 'd' is 0 the result is placed in the W register. If 'd' is 1 the result is placed back in register 'f'.  
 If the result is 0, the next instruction, which is already fetched, is discarded. A NOP is executed instead making it a two-cycle instruction.

Words:      1

Cycles:      1(2)

Example

```

HERE    DECFSZ    REG1, 1
         GOTO    LOOP
CONTINUE •
         •
         •
    
```

Before Instruction  
     PC      = address HERE

After Instruction  
     REG1    = REG1 - 1  
     if REG1 = 0,  
     PC      = address CONTINUE  
     if REG1  $\neq$  0,  
     PC      = address HERE+1

**GOTO**      **Unconditional Branch**

---

Syntax:      [ *label* ] GOTO k

Operands:     $0 \leq k \leq 2047$

Operation:     $k \rightarrow \text{PC}<10:0>$   
 $\text{PCLATH}<4:3> \rightarrow \text{PC}<12:11>$

Status Affected:    None

Encoding:    

10	1kkk	kkkk	kkkk
----	------	------	------

Description:    GOTO is an unconditional branch. The eleven-bit immediate value is loaded into PC bits <10:0>. The upper bits of PC are loaded from PCLATH<4:3>. GOTO is a two-cycle instruction.

Words:      1

Cycles:      2

Example

```

GOTO THERE

After Instruction
    PC = Address THERE
    
```

# PIC16F716

## INCF Increment f

Syntax: `[label] INCF f,d`

Operands:  $0 \leq f \leq 127$   
 $d \in [0,1]$

Operation:  $(f) + 1 \rightarrow (\text{dest})$

Status Affected: Z

Encoding: 

00	1010	dfff	ffff
----	------	------	------

Description: The contents of register 'f' are incremented. If 'd' is 0 the result is placed in the W register. If 'd' is 1 the result is placed back in register 'f'.

Words: 1

Cycles: 1

Example

```
INCF    REG1, 1
Before Instruction
    REG1 = 0xFF
    Z    = 0
After Instruction
    REG1 = 0x00
    Z    = 1
```

## INCFSZ Increment f, Skip if 0

Syntax: `[label] INCFSZ f,d`

Operands:  $0 \leq f \leq 127$   
 $d \in [0,1]$

Operation:  $(f) + 1 \rightarrow (\text{dest})$ , skip if result = 0

Status Affected: None

Encoding: 

00	1111	dfff	ffff
----	------	------	------

Description: The contents of register 'f' are incremented. If 'd' is 0 the result is placed in the W register. If 'd' is 1 the result is placed back in register 'f'.  
 If the result is 0, the next instruction, which is already fetched, is discarded. A NOP is executed instead making it a two-cycle instruction.

Words: 1

Cycles: 1(2)

Example

```
HERE    INCFSZ  REG1, 1
        GOTO    LOOP
CONTINUE •
        •
        •
Before Instruction
    PC    = address HERE
After Instruction
    REG1 = REG1 + 1
    if CNT = 0,
    PC    = address CONTINUE
    if REG1 ≠ 0,
    PC    = address HERE + 1
```



## IORLW Inclusive OR Literal with W

Syntax: [ *label* ] IORLW *k*

Operands:  $0 \leq k \leq 255$

Operation: (W) .OR.  $k \rightarrow (W)$

Status Affected: Z

Encoding: 

11	1000	kkkk	kkkk
----	------	------	------

Description: The contents of the W register is OR'ed with the eight bit literal 'k'. The result is placed in the W register.

Words: 1

Cycles: 1

Example

```

IORLW    0x35
Before Instruction
    W = 0x9A
After Instruction
    W = 0xBF
    Z = 0
    
```

## MOVLW Move Literal to W

Syntax: [ *label* ] MOVLW *k*

Operands:  $0 \leq k \leq 255$

Operation:  $k \rightarrow (W)$

Status Affected: None

Encoding: 

11	00xx	kkkk	kkkk
----	------	------	------

Description: The eight bit literal 'k' is loaded into W register. The don't cares will assemble as '0's.

Words: 1

Cycles: 1

Example

```

MOVLW    0x5A
After Instruction
    W = 0x5A
    
```

## IORWF Inclusive OR W with f

Syntax: [ *label* ] IORWF *f,d*

Operands:  $0 \leq f \leq 127$   
 $d \in [0,1]$

Operation: (W) .OR.  $(f) \rightarrow (dest)$

Status Affected: Z

Encoding: 

00	0100	dfff	ffff
----	------	------	------

Description: Inclusive OR the W register with register 'f'. If 'd' is 0 the result is placed in the W register. If 'd' is 1 the result is placed back in register 'f'.

Words: 1

Cycles: 1

Example

```

IORWF    REG1, 0
Before Instruction
    REG1 = 0x13
    W = 0x91
After Instruction
    REG1 = 0x13
    W = 0x93
    Z = 1
    
```

## MOVF Move f

Syntax: [ *label* ] MOVF *f,d*

Operands:  $0 \leq f \leq 127$   
 $d \in [0,1]$

Operation:  $(f) \rightarrow (dest)$

Status Affected: Z

Encoding: 

00	1000	dfff	ffff
----	------	------	------

Description: The contents of register 'f' is moved to a destination dependent upon the status of 'd'. If 'd' = 0, destination is W register. If 'd' = 1, the destination is file register 'f' itself. 'd' = 1 is useful to test a file register since status flag Z is affected.

Words: 1

Cycles: 1

Example

```

MOVF    REG1, 0
After Instruction
    W = value in REG1 register
    Z = 1
    
```

# PIC16F716

## MOVWF Move W to f

Syntax: [label] MOVWF f  
 Operands:  $0 \leq f \leq 127$   
 Operation: (W) → (f)  
 Status Affected: None  
 Encoding: 

00	0000	1fff	ffff
----	------	------	------

  
 Description: Move data from W register to register 'f'.  
 Words: 1  
 Cycles: 1  
 Example: MOVWF REG1

Before Instruction  
 REG1 = 0xFF  
 W = 0x4F  
 After Instruction  
 REG1 = 0x4F  
 W = 0x4F

## OPTION Load Option Register

Syntax: [label] OPTION  
 Operands: None  
 Operation: (W) → OPTION  
 Status Affected: None  
 Encoding: 

00	0000	0110	0010
----	------	------	------

  
 Description: The contents of the W register are loaded in the OPTION register. This instruction is supported for code compatibility with PIC16C5X products. Since OPTION is a readable/writable register, the user can directly address it. Using only register instruction such as MOVWF.  
 Words: 1  
 Cycles: 1  
 Example:

**To maintain upward compatibility with future PICmicro® products, do not use this instruction.**

## NOP No Operation

Syntax: [label] NOP  
 Operands: None  
 Operation: No operation  
 Status Affected: None  
 Encoding: 

00	0000	0xx0	0000
----	------	------	------

  
 Description: No operation.  
 Words: 1  
 Cycles: 1  
 Example: NOP

## RETFIE Return from Interrupt

Syntax: [label] RETFIE  
 Operands: None  
 Operation: TOS → PC, 1 → GIE  
 Status Affected: None  
 Encoding: 

00	0000	0000	1001
----	------	------	------

  
 Description: Return from Interrupt. Stack is POPed and Top of Stack (TOS) is loaded in the PC. Interrupts are enabled by setting Global Interrupt Enable bit, GIE (INTCON<7>). This is a two-cycle instruction.  
 Words: 1  
 Cycles: 2  
 Example: RETFIE

After Interrupt  
 PC = TOS  
 GIE = 1

## RETLW Return with Literal in W

**Syntax:** `[label] RETLW k`

**Operands:**  $0 \leq k \leq 255$

**Operation:**  $k \rightarrow (W)$ ;  
TOS  $\rightarrow$  PC

**Status Affected:** None

**Encoding:**

11	01xx	kkkk	kkkk
----	------	------	------

**Description:** The W register is loaded with the eight bit literal 'k'. The program counter is loaded from the top of the stack (the return address). This is a two-cycle instruction.

**Words:** 1

**Cycles:** 2

**Example**

```
CALL TABLE;W contains table
    ;offset value
    ;W now has table value
    .
    .
TABLE ADDWF PC;W = offset
      RETLW k1;Begin table
      RETLW k2;
      .
      .
      .
      RETLW kn; End of table

Before Instruction
    W = 0x07
After Instruction
    W = value of k8
```

## RETURN Return from Subroutine

**Syntax:** `[label] RETURN`

**Operands:** None

**Operation:** TOS  $\rightarrow$  PC

**Status Affected:** None

**Encoding:**

00	0000	0000	1000
----	------	------	------

**Description:** Return from subroutine. The stack is POPed and the top of the stack (TOS) is loaded into the program counter. This is a two-cycle instruction.

**Words:** 1

**Cycles:** 2

**Example**

```
RETURN

After Interrupt
    PC = TOS
```

## RLF Rotate Left f through Carry

**Syntax:** `[label] RLF f,d`

**Operands:**  $0 \leq f \leq 127$   
 $d \in [0,1]$


**Operation:** See description below

**Status Affected:** C

**Encoding:**

00	1101	dfff	ffff
----	------	------	------

**Description:** The contents of register 'f' are rotated one bit to the left through the Carry Flag. If 'd' is 0 the result is placed in the W register. If 'd' is 1 the result is stored back in register 'f'.



**Words:** 1

**Cycles:** 1

**Example**

```
RLF    REG1, 0
```

**Before Instruction**

```
REG1=1110 0110
C = 0
```

**After Instruction**

```
REG1=1110 0110
W = 1100 1100
C = 1
```

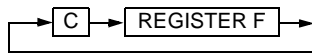
# PIC16F716

## RRF Rotate Right f through Carry

Syntax: [label] RRF f,d  
 Operands:  $0 \leq f \leq 127$   
 $d \in [0,1]$   
 Operation: See description below  
 Status Affected: C  
 Encoding: 

00	1100	dfff	ffff
----	------	------	------

Description: The contents of register 'f' are rotated one bit to the right through the Carry Flag. If 'd' is 0 the result is placed in the W register. If 'd' is 1 the result is placed back in register 'f'.



Words: 1  
 Cycles: 1  
 Example: RRF REG1, 0  
 Before Instruction  
 REG1 = 1110 0110  
 C = 0  
 After Instruction  
 REG1 = 1110 0110  
 W = 0111 0011  
 C = 0

## SLEEP

Syntax: [label] SLEEP  
 Operands: None  
 Operation: 00h → WDT,  
 0 →  $\overline{\text{WDT}}$  prescaler,  
 1 →  $\overline{\text{TO}}$ ,  
 0 →  $\overline{\text{PD}}$   
 Status Affected:  $\overline{\text{TO}}$ ,  $\overline{\text{PD}}$

Encoding: 

00	0000	0110	0011
----	------	------	------

Description: The power-down Status bit,  $\overline{\text{PD}}$  is cleared. Time out Status bit,  $\overline{\text{TO}}$  is set. Watchdog Timer and its prescaler are cleared. The processor is put into Sleep mode with the oscillator stopped.

Words: 1  
 Cycles: 1  
 Example: SLEEP

## SUBLW Subtract W from Literal

Syntax: [label] SUBLW k  
 Operands:  $0 \leq k \leq 255$   
 Operation:  $k - (W) \rightarrow (W)$   
 Status Affected: C, DC, Z  
 Encoding: 

11	110x	kkkk	kkkk
----	------	------	------

Description: The W register is subtracted (2's complement method) from the eight bit literal 'k'. The result is placed in the W register.

Words: 1  
 Cycles: 1  
 Example 1: SUBLW 0x02

Before Instruction  
 W = 1  
 C = ?  
 After Instruction  
 W = 1  
 C = 1; result is positive

Example 2: Before Instruction  
 W = 2  
 C = ?  
 After Instruction  
 W = 0  
 C = 1; result is zero

Example 3: Before Instruction  
 W = 3  
 C = ?  
 After Instruction  
 W = 0xFF  
 C = 0; result is negative

## SUBWF Subtract W from f

Syntax: [ *label* ] SUBWF f,d

Operands:  $0 \leq f \leq 127$   
 $d \in [0,1]$

Operation:  $(f) - (W) \rightarrow (\text{dest})$

Status Affected: C, DC, Z

Encoding:	00	0010	dfff	ffff
-----------	----	------	------	------

Description: Subtract (2's complement method) W register from register 'f'. If 'd' is 0 the result is stored in the W register. If 'd' is 1 the result is stored back in register 'f'.

Words: 1

Cycles: 1

Example 1: SUBWF REG1, 1

Before Instruction

REG1 = 3  
W = 2  
C = ?

After Instruction

REG1 = 1  
W = 2  
C = 1; result is positive  
Z = 0  
DC = 1

Example 2: Before Instruction

REG1 = 2  
W = 2  
C = ?

After Instruction

REG1 = 0  
W = 2  
C = 1; result is zero  
Z = DC = 1

Example 3: Before Instruction

REG1 = 1  
W = 2  
C = ?

After Instruction

REG1 = 0xFF  
W = 2  
C = 0; result is negative  
Z = DC = 0

## SWAPF Swap Nibbles in f

Syntax: [ *label* ] SWAPF f,d

Operands:  $0 \leq f \leq 127$   
 $d \in [0,1]$

Operation:  $(f<3:0>) \rightarrow (\text{dest}<7:4>)$ ,  
 $(f<7:4>) \rightarrow (\text{dest}<3:0>)$

Status Affected: None

Encoding:	00	1110	dfff	ffff
-----------	----	------	------	------

Description: The upper and lower nibbles of register 'f' are exchanged. If 'd' is 0 the result is placed in W register. If 'd' is 1 the result is placed in register 'f'.

Words: 1

Cycles: 1

Example SWAPF REG1, 0

Before Instruction

REG1 = 0xA5

After Instruction

REG1 = 0xA5  
W = 0x5A

TRIS	Load TRIS Register				
Syntax:	[ <i>label</i> ] TRIS f				
Operands:	$5 \leq f \leq 6$				
Operation:	$(W) \rightarrow \text{TRIS register } f$ ;				
Status Affected:	None				
Encoding:	<table border="1"> <tr> <td>00</td> <td>0000</td> <td>0110</td> <td>0fff</td> </tr> </table>	00	0000	0110	0fff
00	0000	0110	0fff		
Description:	The instruction is supported for code compatibility with the PIC16C5X products. Since TRIS registers are readable and writable, the user can directly address them.				
Words:	1				
Cycles:	1				
Example					
<p><b>To maintain upward compatibility with future PICmicro<sup>®</sup> products, do not use this instruction.</b></p>					

# PIC16F716

---

## XORLW Exclusive OR Literal with W

---

Syntax: [ *label* ] XORLW *k*

Operands:  $0 \leq k \leq 255$

Operation: (W) .XOR. *k* → (W)

Status Affected: Z

Encoding: 

11	1010	kkkk	kkkk
----	------	------	------

Description: The contents of the W register are XOR'ed with the eight bit literal '*k*'. The result is placed in the W register.

Words: 1

Cycles: 1

Example: XORLW 0xAF

Before Instruction

W = 0xB5

After Instruction

W = 0x1A

## XORWF Exclusive OR W with f

---

Syntax: [ *label* ] XORWF *f*,*d*

Operands:  $0 \leq f \leq 127$

$d \in [0,1]$

Operation: (W) .XOR. (*f*) → (*dest*)

Status Affected: Z

Encoding: 

00	0110	dfff	ffff
----	------	------	------

Description: Exclusive OR the contents of the W register with register '*f*'. If '*d*' is 0 the result is stored in the W register. If '*d*' is 1 the result is stored back in register '*f*'.

Words: 1

Cycles: 1

Example: XORWF REG1, 1

Before Instruction

REG1 = 0xAF

W = 0xB5

After Instruction

REG1 = 0x1A

W = 0xB5

## 11.0 DEVELOPMENT SUPPORT

The PICmicro<sup>®</sup> microcontrollers are supported with a full range of hardware and software development tools:

- Integrated Development Environment
  - MPLAB<sup>®</sup> IDE Software
- Assemblers/Compilers/Linkers
  - MPASM<sup>™</sup> Assembler
  - MPLAB C17 and MPLAB C18 C Compilers
  - MPLINK<sup>™</sup> Object Linker/  
MPLIB<sup>™</sup> Object Librarian
  - MPLAB C30 C Compiler
  - MPLAB ASM30 Assembler/Linker/Library
- Simulators
  - MPLAB SIM Software Simulator
  - MPLAB dsPIC30 Software Simulator
- Emulators
  - MPLAB ICE 2000 In-Circuit Emulator
  - MPLAB ICE 4000 In-Circuit Emulator
- In-Circuit Debugger
  - MPLAB ICD 2
- Device Programmers
  - PRO MATE<sup>®</sup> II Universal Device Programmer
  - PICSTART<sup>®</sup> Plus Development Programmer
- Low Cost Demonstration Boards
  - PICDEM<sup>™</sup> 1 Demonstration Board
  - PICDEM.net<sup>™</sup> Demonstration Board
  - PICDEM 2 Plus Demonstration Board
  - PICDEM 3 Demonstration Board
  - PICDEM 4 Demonstration Board
  - PICDEM 17 Demonstration Board
  - PICDEM 18R Demonstration Board
  - PICDEM LIN Demonstration Board
  - PICDEM USB Demonstration Board
- Evaluation Kits
  - KEELOQ<sup>®</sup>
  - PICDEM MSC
  - microID<sup>®</sup>
  - CAN
  - PowerSmart<sup>®</sup>
  - Analog

## 11.1 MPLAB Integrated Development Environment Software

The MPLAB IDE software brings an ease of software development previously unseen in the 8/16-bit microcontroller market. The MPLAB IDE is a Windows<sup>®</sup> based application that contains:

- An interface to debugging tools
  - simulator
  - programmer (sold separately)
  - emulator (sold separately)
  - in-circuit debugger (sold separately)
- A full-featured editor with color coded context
- A multiple project manager
- Customizable data windows with direct edit of contents
- High level source code debugging
- Mouse over variable inspection
- Extensive on-line help

The MPLAB IDE allows you to:

- Edit your source files (either assembly or C)
- One touch assemble (or compile) and download to PICmicro emulator and simulator tools (automatically updates all project information)
- Debug using:
  - source files (assembly or C)
  - absolute listing file (mixed assembly and C)
  - machine code

MPLAB IDE supports multiple debugging tools in a single development paradigm, from the cost effective simulators, through low cost in-circuit debuggers, to full-featured emulators. This eliminates the learning curve when upgrading to tools with increasing flexibility and power.

## 11.2 MPASM Assembler

The MPASM assembler is a full-featured, universal macro assembler for all PICmicro MCUs.

The MPASM assembler generates relocatable object files for the MPLINK object linker, Intel<sup>®</sup> standard hex files, MAP files to detail memory usage and symbol reference, absolute LST files that contain source lines and generated machine code and COFF files for debugging.

The MPASM assembler features include:

- Integration into MPLAB IDE projects
- User defined macros to streamline assembly code
- Conditional assembly for multi-purpose source files
- Directives that allow complete control over the assembly process

# PIC16F716

---

## 11.3 MPLAB C17 and MPLAB C18 C Compilers

The MPLAB C17 and MPLAB C18 Code Development Systems are complete ANSI C compilers for Microchip's PIC17CXXX and PIC18CXXX family of microcontrollers. These compilers provide powerful integration capabilities, superior code optimization and ease of use not found with other compilers.

For easy source level debugging, the compilers provide symbol information that is optimized to the MPLAB IDE debugger.

## 11.4 MPLINK Object Linker/ MPLIB Object Librarian

The MPLINK object linker combines relocatable objects created by the MPASM assembler and the MPLAB C17 and MPLAB C18 C compilers. It can link relocatable objects from pre-compiled libraries, using directives from a linker script.

The MPLIB object librarian manages the creation and modification of library files of pre-compiled code. When a routine from a library is called from a source file, only the modules that contain that routine will be linked in with the application. This allows large libraries to be used efficiently in many different applications.

The object linker/library features include:

- Efficient linking of single libraries instead of many smaller files
- Enhanced code maintainability by grouping related modules together
- Flexible creation of libraries with easy module listing, replacement, deletion and extraction

## 11.5 MPLAB C30 C Compiler

The MPLAB C30 C compiler is a full-featured, ANSI compliant, optimizing compiler that translates standard ANSI C programs into dsPIC30F assembly language source. The compiler also supports many command-line options and language extensions to take full advantage of the dsPIC30F device hardware capabilities, and afford fine control of the compiler code generator.

MPLAB C30 is distributed with a complete ANSI C standard library. All library functions have been validated and conform to the ANSI C library standard. The library includes functions for string manipulation, dynamic memory allocation, data conversion, time-keeping, and math functions (trigonometric, exponential and hyperbolic). The compiler provides symbolic information for high level source debugging with the MPLAB IDE.

## 11.6 MPLAB ASM30 Assembler, Linker, and Librarian

MPLAB ASM30 assembler produces relocatable machine code from symbolic assembly language for dsPIC30F devices. MPLAB C30 compiler uses the assembler to produce its object file. The assembler generates relocatable object files that can then be archived or linked with other relocatable object files and archives to create an executable file. Notable features of the assembler include:

- Support for the entire dsPIC30F instruction set
- Support for fixed-point and floating-point data
- Command line interface
- Rich directive set
- Flexible macro language
- MPLAB IDE compatibility

## 11.7 MPLAB SIM Software Simulator

The MPLAB SIM software simulator allows code development in a PC hosted environment by simulating the PICmicro series microcontrollers on an instruction level. On any given instruction, the data areas can be examined or modified and stimuli can be applied from a file, or user defined key press, to any pin. The execution can be performed in Single-Step, Execute Until Break, or Trace mode.

The MPLAB SIM simulator fully supports symbolic debugging using the MPLAB C17 and MPLAB C18 C Compilers, as well as the MPASM assembler. The software simulator offers the flexibility to develop and debug code outside of the laboratory environment, making it an excellent, economical software development tool.

## 11.8 MPLAB SIM30 Software Simulator

The MPLAB SIM30 software simulator allows code development in a PC hosted environment by simulating the dsPIC30F series microcontrollers on an instruction level. On any given instruction, the data areas can be examined or modified and stimuli can be applied from a file, or user defined key press, to any of the pins.

The MPLAB SIM30 simulator fully supports symbolic debugging using the MPLAB C30 C Compiler and MPLAB ASM30 assembler. The simulator runs in either a Command Line mode for automated tasks, or from MPLAB IDE. This high speed simulator is designed to debug, analyze and optimize time intensive DSP routines.



## 11.9 MPLAB ICE 2000 High Performance Universal In-Circuit Emulator

The MPLAB ICE 2000 universal in-circuit emulator is intended to provide the product development engineer with a complete microcontroller design tool set for PICmicro microcontrollers. Software control of the MPLAB ICE 2000 in-circuit emulator is advanced by the MPLAB Integrated Development Environment, which allows editing, building, downloading and source debugging from a single environment.

The MPLAB ICE 2000 is a full-featured emulator system with enhanced trace, trigger and data monitoring features. Interchangeable processor modules allow the system to be easily reconfigured for emulation of different processors. The universal architecture of the MPLAB ICE in-circuit emulator allows expansion to support new PICmicro microcontrollers.

The MPLAB ICE 2000 in-circuit emulator system has been designed as a real-time emulation system with advanced features that are typically found on more expensive development tools. The PC platform and Microsoft® Windows 32-bit operating system were chosen to best make these features available in a simple, unified application.

## 11.10 MPLAB ICE 4000 High Performance Universal In-Circuit Emulator

The MPLAB ICE 4000 universal in-circuit emulator is intended to provide the product development engineer with a complete microcontroller design tool set for high-end PICmicro microcontrollers. Software control of the MPLAB ICE in-circuit emulator is provided by the MPLAB Integrated Development Environment, which allows editing, building, downloading and source debugging from a single environment.

The MPLAB ICE 4000 is a premium emulator system, providing the features of MPLAB ICE 2000, but with increased emulation memory and high speed performance for dsPIC30F and PIC18XXX devices. Its advanced emulator features include complex triggering and timing, up to 2 Mb of emulation memory, and the ability to view variables in real-time.

The MPLAB ICE 4000 in-circuit emulator system has been designed as a real-time emulation system with advanced features that are typically found on more expensive development tools. The PC platform and Microsoft Windows 32-bit operating system were chosen to best make these features available in a simple, unified application.

## 11.11 MPLAB ICD 2 In-Circuit Debugger

Microchip's In-Circuit Debugger, MPLAB ICD 2, is a powerful, low cost, run-time development tool, connecting to the host PC via an RS-232 or high speed USB interface. This tool is based on the Flash PICmicro MCUs and can be used to develop for these and other PICmicro microcontrollers. The MPLAB ICD 2 utilizes the in-circuit debugging capability built into the Flash devices. This feature, along with Microchip's In-Circuit Serial Programming™ (ICSP™) protocol, offers cost effective in-circuit Flash debugging from the graphical user interface of the MPLAB Integrated Development Environment. This enables a designer to develop and debug source code by setting breakpoints, single-stepping and watching variables, CPU status and peripheral registers. Running at full speed enables testing hardware and applications in real-time. MPLAB ICD 2 also serves as a development programmer for selected PICmicro devices.

## 11.12 PRO MATE II Universal Device Programmer

The PRO MATE II is a universal, CE compliant device programmer with programmable voltage verification at VDDMIN and VDDMAX for maximum reliability. It features an LCD display for instructions and error messages and a modular detachable socket assembly to support various package types. In Stand-alone mode, the PRO MATE II device programmer can read, verify, and program PICmicro devices without a PC connection. It can also set code protection in this mode.

## 11.13 PICSTART Plus Development Programmer

The PICSTART Plus development programmer is an easy-to-use, low cost, prototype programmer. It connects to the PC via a COM (RS-232) port. MPLAB Integrated Development Environment software makes using the programmer simple and efficient. The PICSTART Plus development programmer supports most PICmicro devices up to 40 pins. Larger pin count devices, such as the PIC16C92X and PIC17C76X, may be supported with an adapter socket. The PICSTART Plus development programmer is CE compliant.

# PIC16F716

---

## 11.14 PICDEM 1 PICmicro Demonstration Board

The PICDEM 1 demonstration board demonstrates the capabilities of the PIC16C5X (PIC16C54 to PIC16C58A), PIC16C61, PIC16C62X, PIC16C71, PIC16C8X, PIC17C42, PIC17C43 and PIC17C44. All necessary hardware and software is included to run basic demo programs. The sample microcontrollers provided with the PICDEM 1 demonstration board can be programmed with a PRO MATE II device programmer, or a PICSTART Plus development programmer. The PICDEM 1 demonstration board can be connected to the MPLAB ICE in-circuit emulator for testing. A prototype area extends the circuitry for additional application components. Features include an RS-232 interface, a potentiometer for simulated analog input, push button switches and eight LEDs.

## 11.15 PICDEM.net Internet/Ethernet Demonstration Board

The PICDEM.net demonstration board is an Internet/Ethernet demonstration board using the PIC18F452 microcontroller and TCP/IP firmware. The board supports any 40-pin DIP device that conforms to the standard pinout used by the PIC16F877 or PIC18C452. This kit features a user friendly TCP/IP stack, web server with HTML, a 24L256 Serial EEPROM for Xmodem download to web pages into Serial EEPROM, ICSP/MPLAB ICD 2 interface connector, an Ethernet interface, RS-232 interface, and a 16 x 2 LCD display. Also included is the book and CD-ROM *"TCP/IP Lean, Web Servers for Embedded Systems,"* by Jeremy Bentham

## 11.16 PICDEM 2 Plus Demonstration Board

The PICDEM 2 Plus demonstration board supports many 18-, 28-, and 40-pin microcontrollers, including PIC16F87X and PIC18FXX2 devices. All the necessary hardware and software is included to run the demonstration programs. The sample microcontrollers provided with the PICDEM 2 demonstration board can be programmed with a PRO MATE II device programmer, PICSTART Plus development programmer, or MPLAB ICD 2 with a Universal Programmer Adapter. The MPLAB ICD 2 and MPLAB ICE in-circuit emulators may also be used with the PICDEM 2 demonstration board to test firmware. A prototype area extends the circuitry for additional application components. Some of the features include an RS-232 interface, a 2 x 16 LCD display, a piezo speaker, an on-board temperature sensor, four LEDs, and sample PIC18F452 and PIC16F877 Flash microcontrollers.

## 11.17 PICDEM 3 PIC16C92X Demonstration Board

The PICDEM 3 demonstration board supports the PIC16C923 and PIC16C924 in the PLCC package. All the necessary hardware and software is included to run the demonstration programs.

## 11.18 PICDEM 4 8/14/18-Pin Demonstration Board

The PICDEM 4 can be used to demonstrate the capabilities of the 8-, 14-, and 18-pin PIC16XXXX and PIC18XXXX MCUs, including the PIC16F818/819, PIC16F87/88, PIC16F62XA and the PIC18F1320 family of microcontrollers. PICDEM 4 is intended to showcase the many features of these low pin count parts, including LIN and Motor Control using ECCP. Special provisions are made for low power operation with the super capacitor circuit, and jumpers allow on-board hardware to be disabled to eliminate current draw in this mode. Included on the demo board are provisions for Crystal, RC or Canned Oscillator modes, a five volt regulator for use with a nine volt wall adapter or battery, DB-9 RS-232 interface, ICD connector for programming via ICSP and development with MPLAB ICD 2, 2x16 liquid crystal display, PCB footprints for H-Bridge motor driver, LIN transceiver and EEPROM. Also included are: header for expansion, eight LEDs, four potentiometers, three push buttons and a prototyping area. Included with the kit is a PIC16F627A and a PIC18F1320. Tutorial firmware is included along with the User's Guide.

## 11.19 PICDEM 17 Demonstration Board

The PICDEM 17 demonstration board is an evaluation board that demonstrates the capabilities of several Microchip microcontrollers, including PIC17C752, PIC17C756A, PIC17C762 and PIC17C766. A programmed sample is included. The PRO MATE II device programmer, or the PICSTART Plus development programmer, can be used to reprogram the device for user tailored application development. The PICDEM 17 demonstration board supports program download and execution from external on-board Flash memory. A generous prototype area is available for user hardware expansion.

## 11.20 PICDEM 18R PIC18C601/801 Demonstration Board

The PICDEM 18R demonstration board serves to assist development of the PIC18C601/801 family of Microchip microcontrollers. It provides hardware implementation of both 8-bit Multiplexed/De-multiplexed and 16-bit memory modes. The board includes 2 Mb external Flash memory and 128 Kb SRAM memory, as well as serial EEPROM, allowing access to the wide range of memory types supported by the PIC18C601/801.

## 11.21 PICDEM LIN PIC16C43X Demonstration Board

The powerful LIN hardware and software kit includes a series of boards and three PICmicro microcontrollers. The small footprint PIC16C432 and PIC16C433 are used as slaves in the LIN communication and feature on-board LIN transceivers. A PIC16F874 Flash microcontroller serves as the master. All three microcontrollers are programmed with firmware to provide LIN bus communication.

## 11.22 PICkit™ 1 Flash Starter Kit

A complete "development system in a box", the PICkit Flash Starter Kit includes a convenient multi-section board for programming, evaluation, and development of 8/14-pin Flash PIC® microcontrollers. Powered via USB, the board operates under a simple Windows GUI. The PICkit 1 Starter Kit includes the user's guide (on CD ROM), PICkit 1 tutorial software and code for various applications. Also included are MPLAB® IDE (Integrated Development Environment) software, software and hardware "Tips 'n Tricks for 8-pin Flash PIC® Microcontrollers" Handbook and a USB Interface Cable. Supports all current 8/14-pin Flash PIC microcontrollers, as well as many future planned devices.

## 11.23 PICDEM USB PIC16C7X5 Demonstration Board

The PICDEM USB Demonstration Board shows off the capabilities of the PIC16C745 and PIC16C765 USB microcontrollers. This board provides the basis for future USB products.

## 11.24 Evaluation and Programming Tools

In addition to the PICDEM series of circuits, Microchip has a line of evaluation kits and demonstration software for these products.

- KEELOQ evaluation and programming tools for Microchip's HCS Secure Data Products
- CAN developers kit for automotive network applications
- Analog design boards and filter design software
- PowerSmart battery charging evaluation/calibration kits
- IrDA® development kit
- microID development and rfLab™ development software
- SEEVAL® designer kit for memory evaluation and endurance calculations
- PICDEM MSC demo boards for Switching mode power supply, high power IR driver, delta sigma ADC, and flow rate sensor

Check the Microchip web page and the latest Product Line Card for the complete list of demonstration and evaluation kits.

# PIC16F716

---

NOTES:

## 12.0 ELECTRICAL CHARACTERISTICS

### Absolute Maximum Ratings<sup>(†)</sup>

Ambient temperature under bias.....	-55°C to +125°C
Storage temperature .....	-65°C to +150°C
Voltage on any pin with respect to V <sub>SS</sub> (except V <sub>DD</sub> , $\overline{\text{MCLR}}$ , and RA4) .....	-0.3V to (V <sub>DD</sub> +0.3V)
Voltage on V <sub>DD</sub> with respect to V <sub>SS</sub> .....	-0.3V to +7.5V
Voltage on $\overline{\text{MCLR}}$ with respect to V <sub>SS</sub> ( <b>Note 2</b> ) .....	0V to +13.25V
Voltage on RA4 with respect to V <sub>SS</sub> .....	0V to +8.5V
Total power dissipation ( <b>Note 1</b> ) (PDIP and SOIC).....	1.0W
Total power dissipation ( <b>Note 1</b> ) (SSOP) .....	0.65W
Maximum current out of V <sub>SS</sub> pin .....	300 mA
Maximum current into V <sub>DD</sub> pin .....	250 mA
Input clamp current, I <sub>IK</sub> (V <sub>I</sub> < 0 or V <sub>I</sub> > V <sub>DD</sub> ).....	±20 mA
Output clamp current, I <sub>OK</sub> (V <sub>O</sub> < 0 or V <sub>O</sub> > V <sub>DD</sub> ) .....	±20 mA
Maximum output current sunk by any I/O pin.....	25 mA
Maximum output current sourced by any I/O pin .....	25 mA
Maximum current sunk by PORTA and PORTB (combined).....	200 mA
Maximum current sourced by PORTA and PORTB (combined) .....	200 mA

**Note 1:** Power dissipation is calculated as follows:  $P_{dis} = V_{DD} \times \{I_{DD} - \sum I_{OH}\} + \sum \{(V_{DD} - V_{OH}) \times I_{OH}\} + \sum (V_{OL} \times I_{OL})$

**2:** Voltage spikes below V<sub>SS</sub> at the  $\overline{\text{MCLR}}/\text{VPP}$  pin, inducing currents greater than 80 mA, may cause latch-up. Thus, a series resistor of 50-100Ω should be used when applying a “low” level to the  $\overline{\text{MCLR}}/\text{VPP}$  pin rather than pulling this pin directly to V<sub>SS</sub>.

† NOTICE: Stresses above those listed under “Absolute Maximum Ratings” may cause permanent damage to the device. This is a stress rating only and functional operation of the device at those or any other conditions above those indicated in the operation listings of this specification is not implied. Exposure to maximum rating conditions for extended periods may affect device reliability.

# PIC16F716

FIGURE 12-1: PIC16F716 VOLTAGE-FREQUENCY GRAPH,  $-40^{\circ}\text{C} \leq T_A \leq +85^{\circ}\text{C}^{(1)}$

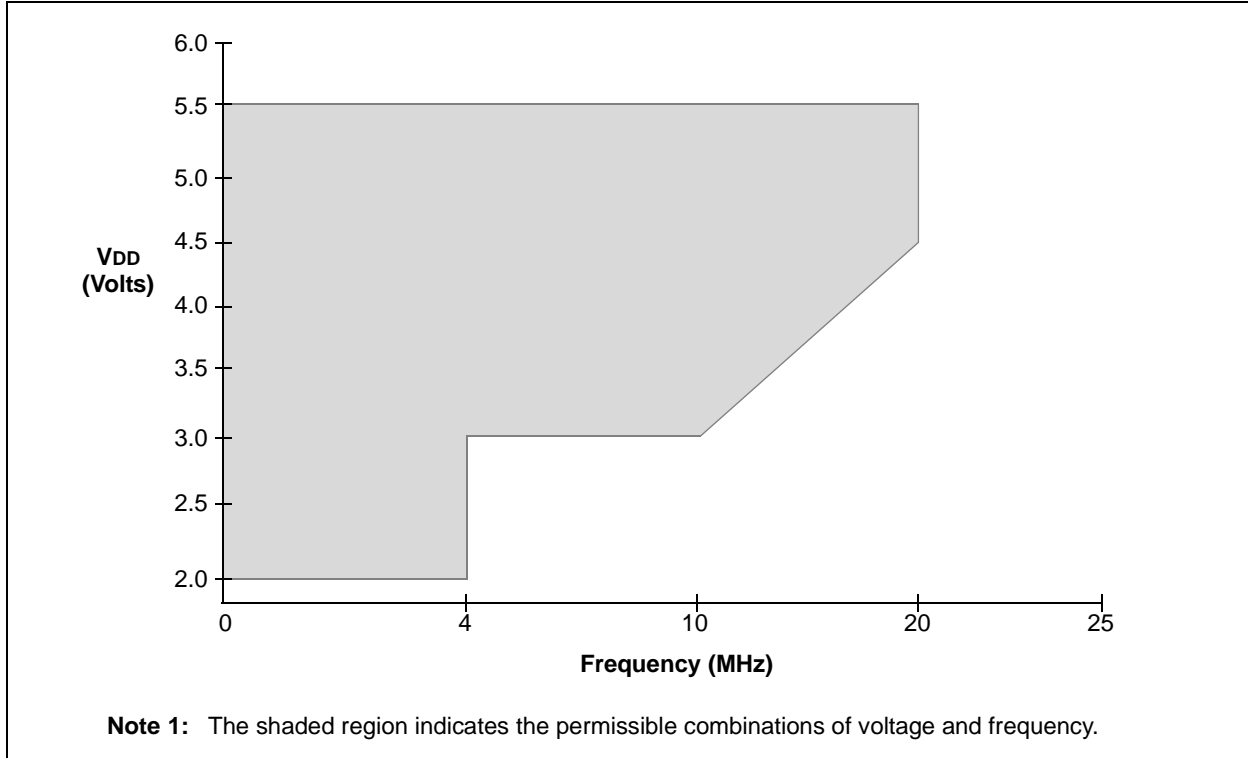
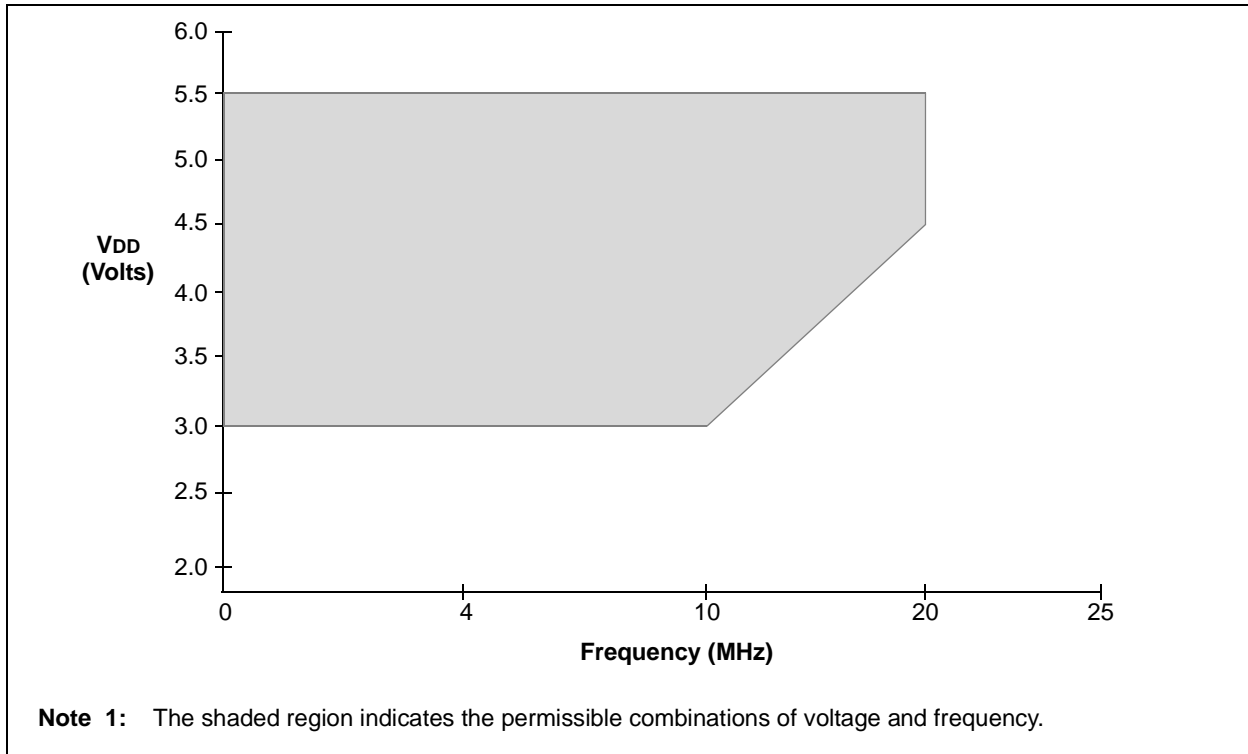


FIGURE 12-2: PIC16F716 VOLTAGE-FREQUENCY GRAPH,  $85^{\circ}\text{C} \leq T_A \leq +125^{\circ}\text{C}^{(1)}$



## 12.1 DC Characteristics: PIC16F716 (Industrial, Extended)

DC CHARACTERISTICS			Standard Operating Conditions (unless otherwise stated) Operating temperature $-40^{\circ}\text{C} \leq T_A \leq +85^{\circ}\text{C}$ for industrial $-40^{\circ}\text{C} \leq T_A \leq +125^{\circ}\text{C}$ for extended				
Param No.	Sym	Characteristic	Min	Typ†	Max	Units	Conditions
D001 D001A	VDD	<b>Supply Voltage</b>					
			2.0 3.0	— —	5.5 5.5	V V	Industrial Extended
D002*	VDR	<b>RAM Data Retention Voltage<sup>(1)</sup></b>	—	1.5*	—	V	
D003	VPOR	<b>VDD Start Voltage</b> to ensure internal Power-on Reset signal	—	Vss	—	V	See section on Power-on Reset for details
D004* D004A*	SVDD	<b>VDD Rise Rate</b> to ensure internal Power-on Reset signal	0.05 TBD	— —	— —	V/ms	PWRT enabled ( $\overline{\text{PWRTE}}$ bit clear) PWRT disabled ( $\overline{\text{PWRTE}}$ bit set) See section on Power-on Reset for details
D005	VBOR	<b>Brown-out Reset</b> voltage trip point					
			3.65 TBD	4.0 2.5	4.35 TBD	V V	BOREN bit set, BOR bit = '1' BOREN bit set, BOR bit = '0'

\* These parameters are characterized but not tested.

† Data in "Typ" column is at 5V, 25°C unless otherwise stated. These parameters are for design guidance only and are not tested.

**Note 1:** This is the limit to which VDD can be lowered without losing RAM data.

# PIC16F716

## 12.2 DC Characteristics: PIC16F716 (Industrial)

DC CHARACTERISTICS			Standard Operating Conditions (unless otherwise stated) Operating temperature $-40^{\circ}\text{C} \leq T_A \leq +85^{\circ}\text{C}$					
Para m No.	Sym	Characteristic	Min	Typ†	Max	Units	VDD	Conditions
D001	VDD	Supply Voltage						
			2.0	—	5.5	V	—	
D020	IPD	Power-down Base Current	—	0.1	0.8	$\mu\text{A}$	2.0	WDT, BOR and T1OSC: disabled
			—	0.1	0.85	$\mu\text{A}$	3.0	
			—	0.2	2.7	$\mu\text{A}$	5.0	
D021	$\Delta\text{IMOD}$	Peripheral Module Current <sup>(1)</sup>	—	1	2.0	$\mu\text{A}$	2.0	WDT Current
			—	2	3.5	$\mu\text{A}$	3.0	
			—	9	13.5	$\mu\text{A}$	5.0	
D022			—	TBD	TBD	$\mu\text{A}$	3.0	BOR Current
			—	40	TBD	$\mu\text{A}$	4.5	
			—	45	TBD	$\mu\text{A}$	5.0	
D025			—	1.8	TBD	$\mu\text{A}$	2.0	T1osc Current
			—	2.6	TBD	$\mu\text{A}$	3.0	
			—	3.0	TBD	$\mu\text{A}$	5.0	
D010	IDD	Supply Current	—	14	17	$\mu\text{A}$	2.0	Fosc = 32 kHz LP Oscillator mode
			—	23	28	$\mu\text{A}$	3.0	
			—	45	60	$\mu\text{A}$	5.0	
D011			—	120	160	$\mu\text{A}$	2.0	Fosc = 1 MHz XT Oscillator mode
			—	180	250	$\mu\text{A}$	3.0	
			—	290	370	$\mu\text{A}$	5.0	
D012			—	220	300	$\mu\text{A}$	2.0	Fosc = 4 MHz XT Oscillator mode
			—	350	470	$\mu\text{A}$	3.0	
			—	600	780	$\mu\text{A}$	5.0	
D013			—	2.1	2.9	$\text{mA}$	4.5	Fosc = 20 MHz HS Oscillator mode
			—	2.5	3.3	$\text{mA}$	5.0	

† Data in "Typ" column is at 5V, 25°C unless otherwise stated. These parameters are for design guidance only and are not tested.

**Note 1:** The "Δ" current is the additional current consumed when this peripheral is enabled. This current should be added to the base IDD or IPD measurement. Max values should be used when calculating total current consumption.

**2:** ADC on, not converting.



## 12.3 DC Characteristics: PIC16F716 (Extended)

DC CHARACTERISTICS			Standard Operating Conditions (unless otherwise stated) Operating temperature $-40^{\circ}\text{C} \leq T_A \leq +125^{\circ}\text{C}$					
Param No.	Sym	Characteristic	Min	Typ†	Max	Units	VDD	Conditions
D001	VDD	<b>Supply Voltage</b>	3.0	—	5.5	V	—	
D020E	IPD	<b>Power-down Base Current</b>	—	0.1	TBD	$\mu\text{A}$	3.0	WDT, BOR and T1OSC: disabled
			—	0.2	TBD	$\mu\text{A}$	5.0	
D021E	$\Delta\text{IMOD}$	<b>Peripheral Module Current<sup>(1)</sup></b>	—	2	TBD	$\mu\text{A}$	3.0	WDT Current
			—	9	TBD	$\mu\text{A}$	5.0	
D022E			—	TBD	TBD	$\mu\text{A}$	3.0	BOR Current
			—	40	TBD	$\mu\text{A}$	4.5	
			—	45	TBD	$\mu\text{A}$	5.0	
D025E			—	2.6	TBD	$\mu\text{A}$	3.0	T1osc Current
			—	3.0	TBD	$\mu\text{A}$	5.0	
D010E	IDD	<b>Supply Current</b>	—	21	TBD	$\mu\text{A}$	3.0	Fosc = 32 kHz LP Oscillator mode
			—	38	TBD	$\mu\text{A}$	5.0	
D011E			—	182	TBD	$\mu\text{A}$	3.0	Fosc = 1 MHz XT Oscillator mode
			—	293	TBD	$\mu\text{A}$	5.0	
D012E			—	371	TBD	$\mu\text{A}$	3.0	Fosc = 4 MHz XT Oscillator mode
			—	668	TBD	$\mu\text{A}$	5.0	
D013E			—	2.6	TBD	mA	4.5	Fosc = 20 MHz HS Oscillator mode
			—	3	TBD	mA	5.0	

† Data in "Typ" column is at 5V, 25°C unless otherwise stated. These parameters are for design guidance only and are not tested.

**Note 1:** The "Δ" current is the additional current consumed when this peripheral is enabled. This current should be added to the base IDD or IPD measurement. Max values should be used when calculating total current consumption.

**2:** ADC on, not converting.

# PIC16F716

## 12.4 DC Characteristics: PIC16F716 (Industrial, Extended)

DC CHARACTERISTICS		Standard Operating Conditions (unless otherwise stated)						
		Operating temperature $-40^{\circ}\text{C} \leq T_A \leq +85^{\circ}\text{C}$ for industrial $-40^{\circ}\text{C} \leq T_A \leq +125^{\circ}\text{C}$ for extended						
		Operating voltage $V_{DD}$ range as described in DC spec Section 12.1 “DC Characteristics: PIC16F716 (Industrial, Extended)” and Section 12.4 “DC Characteristics: PIC16F716 (Industrial, Extended)”.						
Param No.	Sym	Characteristic	Min	Typ†	Max	Units	Conditions	
<b>Input Low Voltage</b>								
D030 D030A	V <sub>IL</sub>	I/O ports with TTL buffer	V <sub>SS</sub>	—	0.8	V	$4.5\text{V} \leq V_{DD} \leq 5.5\text{V}$ otherwise	
D031 D032		with Schmitt Trigger buffer MCLR, OSC1 (in RC mode)	V <sub>SS</sub>	—	0.15 V <sub>DD</sub> 0.2 V <sub>DD</sub>	V		
D033		OSC1 (in HS mode) OSC1 (in XT and LP modes)	V <sub>SS</sub>	—	0.3 V <sub>DD</sub> 0.6	V	<b>(Note1)</b>	
<b>Input High Voltage</b>								
D040 D040A		V <sub>IH</sub>	I/O ports with TTL buffer	2.0	—	V <sub>DD</sub>	V	$4.5\text{V} \leq V_{DD} \leq 5.5\text{V}$ otherwise
D041 D042	with Schmitt Trigger buffer MCLR		0.25 V <sub>DD</sub> + 0.8V	—	V <sub>DD</sub>	V		
D042A D043	OSC1 (XT, HS and LP modes) OSC1 (in RC mode)		0.8 V <sub>DD</sub> 0.7 V <sub>DD</sub> 0.9 V <sub>DD</sub>	—	V <sub>DD</sub>	V	<b>(Note1)</b>	
<b>Input Leakage Current<sup>(2), (3)</sup></b>								
D060 D061 D063	I <sub>IL</sub>		I/O ports	—	—	±1	μA	$V_{SS} \leq V_{PIN} \leq V_{DD}$ , Pin at high-impedance $V_{SS} \leq V_{PIN} \leq V_{DD}$ , Pin configured as analog input
D061 D063		MCLR, RA4/T0CKI OSC1/CLKIN	—	—	±500 ±5 ±5	nA μA μA	$V_{SS} \leq V_{PIN} \leq V_{DD}$ $V_{SS} \leq V_{PIN} \leq V_{DD}$ , XT, HS and LP osc modes	
D070		IPURB	<b>PORTB weak pull-up current</b>	50	250	400	μA	$V_{DD} = 5\text{V}$ , $V_{PIN} = V_{SS}$
<b>Output Low Voltage</b>								
D080 D083	V <sub>OL</sub>	I/O ports	—	—	0.6	V	I <sub>OL</sub> = 8.5 mA, $V_{DD} = 4.5\text{V}$ , $-40^{\circ}\text{C}$ to $+85^{\circ}\text{C}$ I <sub>OL</sub> = 7.0 mA, $V_{DD} = 4.5\text{V}$ , $-40^{\circ}\text{C}$ to $+125^{\circ}\text{C}$	
D083		OSC2/CLKOUT (RC Osc mode)	—	—	0.6	V		
				—	—	0.6	V	I <sub>OL</sub> = 1.6 mA, $V_{DD} = 4.5\text{V}$ , $-40^{\circ}\text{C}$ to $+85^{\circ}\text{C}$
				—	—	0.6	V	I <sub>OL</sub> = 1.2 mA, $V_{DD} = 4.5\text{V}$ , $-40^{\circ}\text{C}$ to $+125^{\circ}\text{C}$
<b>Output High Voltage</b>								
D090 D092	V <sub>OH</sub>	I/O ports <sup>(3)</sup>	V <sub>DD</sub> -0.7	—	—	V	I <sub>OH</sub> = -3.0 mA, $V_{DD} = 4.5\text{V}$ , $-40^{\circ}\text{C}$ to $+85^{\circ}\text{C}$ I <sub>OH</sub> = -2.5 mA, $V_{DD} = 4.5\text{V}$ , $-40^{\circ}\text{C}$ to $+125^{\circ}\text{C}$	
D092		OSC2/CLKOUT (RC Osc mode)	V <sub>DD</sub> -0.7	—	—	V		
				V <sub>DD</sub> -0.7	—	—	V	I <sub>OH</sub> = -1.3 mA, $V_{DD} = 4.5\text{V}$ , $-40^{\circ}\text{C}$ to $+85^{\circ}\text{C}$
				V <sub>DD</sub> -0.7	—	—	V	I <sub>OH</sub> = -1.0 mA, $V_{DD} = 4.5\text{V}$ , $-40^{\circ}\text{C}$ to $+125^{\circ}\text{C}$
D150*	V <sub>OD</sub>	<b>Open-Drain High Voltage</b>	—	—	8.5	V	RA4 pin	

\* These parameters are characterized but not tested.

† Data in “Type” column is at 5V, 25°C unless otherwise stated. These parameters are for design guidance only and are not tested.

- Note 1:** In RC Oscillator mode, the OSC1/CLKIN pin is a Schmitt Trigger input. It is not recommended that the PICmicro be driven with external clock in RC mode.
- 2:** The leakage current on the MCLR/VPP pin is strongly dependent on the applied voltage level. The specified levels represent normal operating conditions. Higher leakage current may be measured at different input voltages.
- 3:** Negative current is defined as current sourced by the pin.

DC CHARACTERISTICS		Standard Operating Conditions (unless otherwise stated)					
		Operating temperature $-40^{\circ}\text{C} \leq T_A \leq +85^{\circ}\text{C}$ for industrial $-40^{\circ}\text{C} \leq T_A \leq +125^{\circ}\text{C}$ for extended					
		Operating voltage $V_{DD}$ range as described in DC spec <b>Section 12.1 “DC Characteristics: PIC16F716 (Industrial, Extended)”</b> and <b>Section 12.4 “DC Characteristics: PIC16F716 (Industrial, Extended)”</b> .					
Param No.	Sym	Characteristic	Min	Typ†	Max	Units	Conditions
<b>Capacitive Loading Specs on Output Pins</b>							
D100	COSC2	OSC2/CLKOUT pin	—	—	15	pF	In XT, HS and LP modes when external clock is used to drive OSC1.
D101	Cio	All I/O pins and OSC2 (in RC mode)	—	—	50	pF	

\* These parameters are characterized but not tested.

† Data in “Type” column is at 5V, 25°C unless otherwise stated. These parameters are for design guidance only and are not tested.

- Note**
- 1: In RC Oscillator mode, the OSC1/CLKIN pin is a Schmitt Trigger input. It is not recommended that the PICmicro be driven with external clock in RC mode.
  - 2: The leakage current on the  $\overline{\text{MCLR}}/V_{PP}$  pin is strongly dependent on the applied voltage level. The specified levels represent normal operating conditions. Higher leakage current may be measured at different input voltages.
  - 3: Negative current is defined as current sourced by the pin.

## 12.5 AC (Timing) Characteristics

### 12.5.1 TIMING PARAMETER SYMBOLOGY

The timing parameter symbols have been created using one of the following formats:

1. TppS2ppS
2. TppS

T		T	
F	Frequency	T	Time

Lowercase letters (pp) and their meanings:

pp		pp	
cc	CCP1	osc	OSC1
ck	CLKOUT	rd	$\overline{\text{RD}}$
cs	$\overline{\text{CS}}$	rw	$\overline{\text{RD}}$ or $\overline{\text{WR}}$
di	SDI	sc	SCK
do	SDO	ss	$\overline{\text{SS}}$
dt	Data in	t0	T0CKI
io	I/O port	t1	T1CKI
mc	$\overline{\text{MCLR}}$	wr	$\overline{\text{WR}}$

Uppercase letters and their meanings:

S		S	
F	Fall	P	Period
H	High	R	Rise
I	Invalid (Hi-impedance)	V	Valid
L	Low	Z	Hi-impedance

# PIC16F716

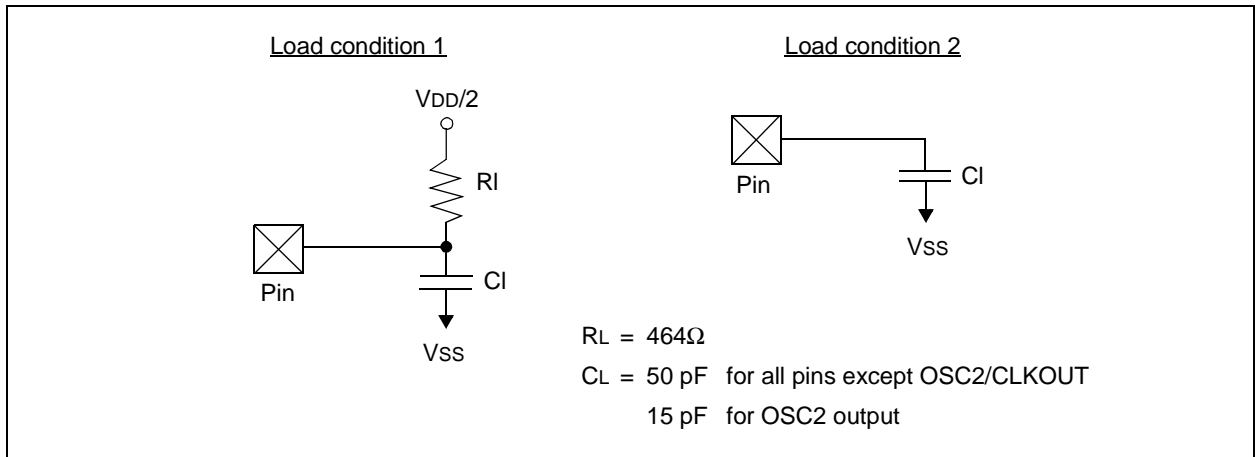
## 12.5.2 TIMING CONDITIONS

The temperature and voltages specified in Table 12-1 apply to all timing specifications, unless otherwise noted. Figure 12-3 specifies the load conditions for the timing specifications.

**TABLE 12-1: TEMPERATURE AND VOLTAGE SPECIFICATIONS - AC**

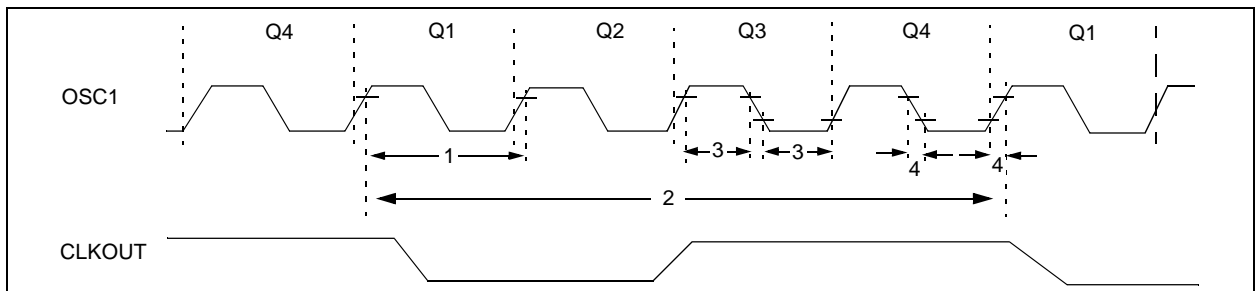
<b>AC CHARACTERISTICS</b>	<b>Standard Operating Conditions (unless otherwise stated)</b>
	Operating temperature $-40^{\circ}\text{C} \leq T_A \leq +85^{\circ}\text{C}$ for industrial $-40^{\circ}\text{C} \leq T_A \leq +125^{\circ}\text{C}$ for extended Operating voltage $V_{DD}$ range as described in DC spec <b>Section 12.1 “DC Characteristics: PIC16F716 (Industrial, Extended)”</b> and <b>Section 12.4 “DC Characteristics: PIC16F716 (Industrial, Extended)”</b> . LC parts operate for commercial/industrial temp's only.

**FIGURE 12-3: LOAD CONDITIONS FOR DEVICE TIMING SPECIFICATIONS**



## 12.5.3 TIMING DIAGRAMS AND SPECIFICATIONS

**FIGURE 12-4: EXTERNAL CLOCK TIMING**



**TABLE 12-2: EXTERNAL CLOCK TIMING REQUIREMENTS**

Param No.	Sym	Characteristic	Min	Typ†	Max	Units	Conditions
1A	Fosc	Ext. Clock Input Frequency <sup>(1)</sup>	DC	—	4	MHz	RC and XT Osc modes
			DC	—	20	MHz	HS Osc mode
			DC	—	200	kHz	LP Osc mode
		Oscillator Frequency <sup>(1)</sup>	DC	—	4	MHz	RC Osc mode
0.1	—		4	MHz	XT Osc mode		
4	—		20	MHz	HS Osc mode		
5	—		200	kHz	LP Osc mode		
1	Tosc	External CLKIN Period <sup>(1)</sup>	250	—	—	ns	RC and XT Osc modes
			50	—	—	ns	HS Osc mode
			5	—	—	μs	LP Osc mode
		Oscillator Period <sup>(1)</sup>	250	—	—	ns	RC Osc mode
			250	—	10,000	ns	XT Osc mode
			50	—	250	ns	HS Osc mode
5	—	—	μs	LP Osc mode			
2	Tcy	Instruction Cycle Time <sup>(1)</sup>	200	—	DC	ns	T <sub>cy</sub> = 4/F <sub>osc</sub>
3*	TosL, TosH	External Clock in (OSC1) High or Low Time	100	—	—	ns	XT oscillator
			2.5	—	—	μs	LP oscillator
			15	—	—	ns	HS oscillator
4*	TosR, TosF	External Clock in (OSC1) Rise or Fall Time	—	—	25	ns	XT oscillator
			—	—	50	ns	LP oscillator
			—	—	15	ns	HS oscillator

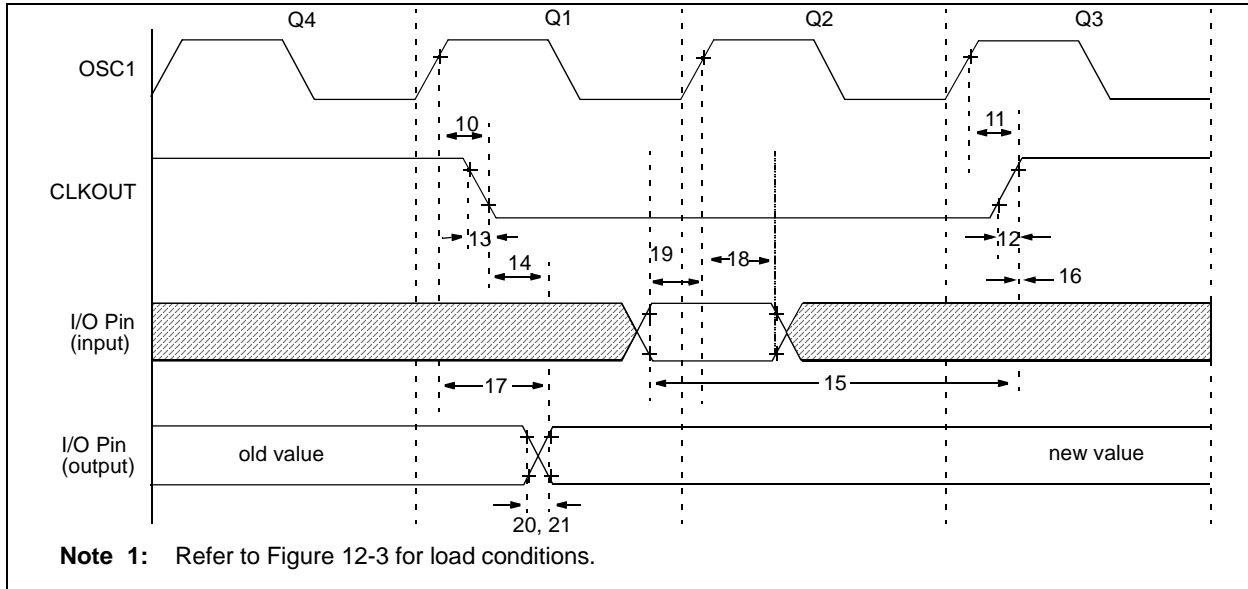
\* These parameters are characterized but not tested.

† Data in "Typ" column is at 5V, 25°C unless otherwise stated. These parameters are for design guidance only and are not tested.

**Note 1:** Instruction cycle period (T<sub>cy</sub>) equals four times the input oscillator time base period. All specified values are based on characterization data for that particular oscillator type under standard operating conditions with the device executing code. Exceeding these specified limits may result in an unstable oscillator operation and/or higher than expected current consumption. All devices are tested to operate at "min." values with an external clock applied to the OSC1/CLKIN pin.  
When an external clock input is used, the "Max." cycle time limit is "DC" (no clock) for all devices.

# PIC16F716

**FIGURE 12-5: CLKOUT AND I/O TIMING**



**TABLE 12-3: CLKOUT AND I/O TIMING REQUIREMENTS**

Param No.	Sym	Characteristic	Min	Typ †	Max	Units	Conditions	
10*	TosH2ckL	OSC1↑ to CLKOUT↓	—	75	200	ns	(Note 1)	
11*	TosH2ckH	OSC1↑ to CLKOUT↑	—	75	200	ns	(Note 1)	
12*	TckR	CLKOUT rise time	—	35	100	ns	(Note 1)	
13*	TckF	CLKOUT fall time	—	35	100	ns	(Note 1)	
14*	TckL2ioV	CLKOUT ↓ to Port out valid	—	—	20	ns	(Note 1)	
15*	TioV2ckH	Port input valid before CLKOUT ↑	Tosc + 200	—	—	ns	(Note 1)	
16*	TckH2ioI	Port input hold after CLKOUT ↑	0	—	—	ns	(Note 1)	
17*	TosH2ioV	OSC1↑ (Q1 cycle) to Port out valid	—	50	150	ns		
18*	TosH2ioI	OSC1↑ (Q2 cycle) to Port input invalid (I/O in hold time)	Standard	100	—	—	ns	
18A*			Extended (LC)	200	—	—	ns	
19*	TioV2osH	Port input valid to OSC1↑ (I/O in setup time)	0	—	—	ns		
20*	TioR	Port output rise time	Standard	—	10	40	ns	
20A*			Extended (LC)	—	—	80	ns	
21*	TioF	Port output fall time	Standard	—	10	40	ns	
21A*			Extended (LC)	—	—	80	ns	
22††*	TINP	INT pin high or low time	Tcy	—	—	ns		
23††*	TRBP	RB7:RB4 change INT high or low time	Tcy	—	—	ns		

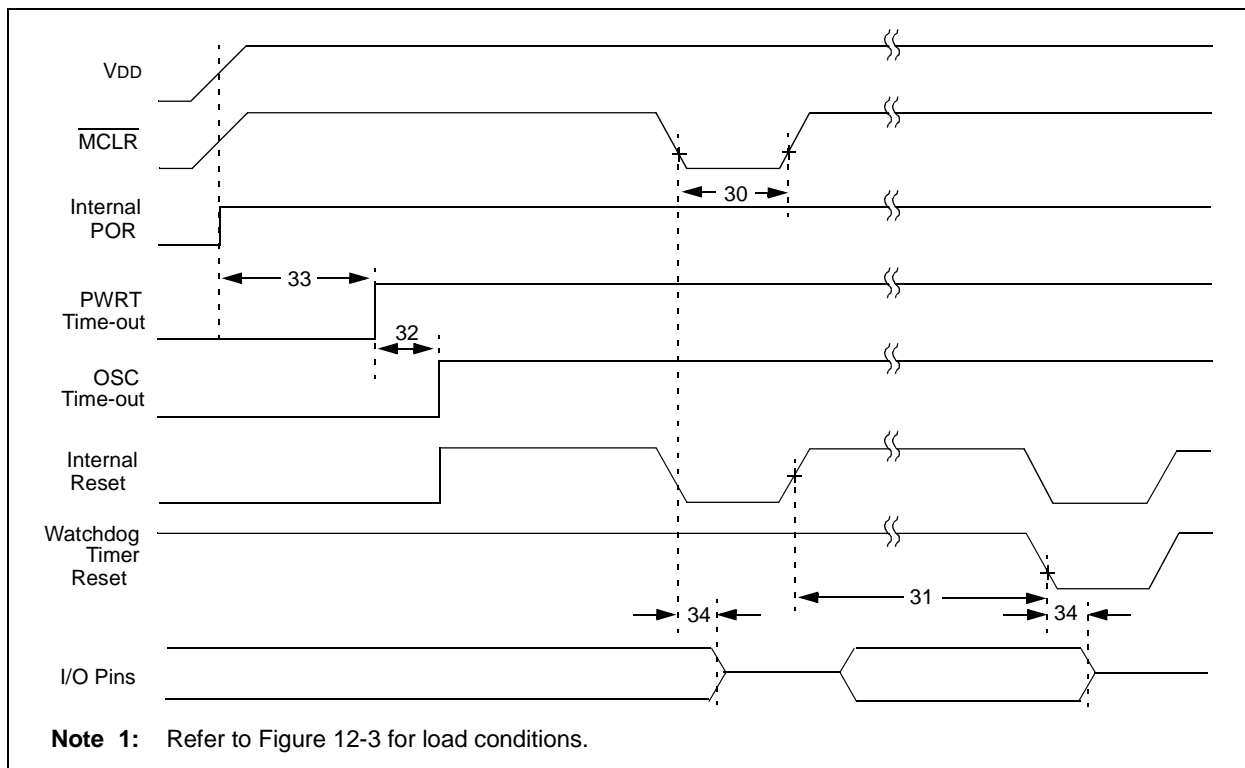
\* These parameters are characterized but not tested.

† Data in "Typ" column is at 5V, 25°C unless otherwise stated. These parameters are for design guidance only and are not tested.

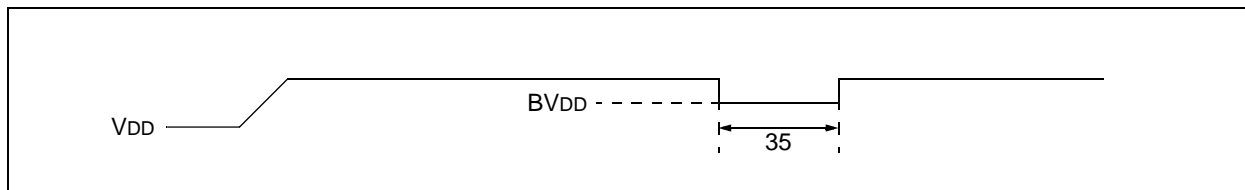
†† These parameters are asynchronous events not related to any internal clock edge.

**Note 1:** Measurements are taken in RC mode where CLKOUT output is 4 x TOSC.

**FIGURE 12-6: RESET, WATCHDOG TIMER, OSCILLATOR START-UP TIMER AND POWER-UP TIMER TIMING<sup>(1)</sup>**



**FIGURE 12-7: BROWN-OUT RESET TIMING**



**TABLE 12-4: RESET, WATCHDOG TIMER, OSCILLATOR START-UP TIMER, POWER-UP TIMER, AND BROWN-OUT RESET REQUIREMENTS**

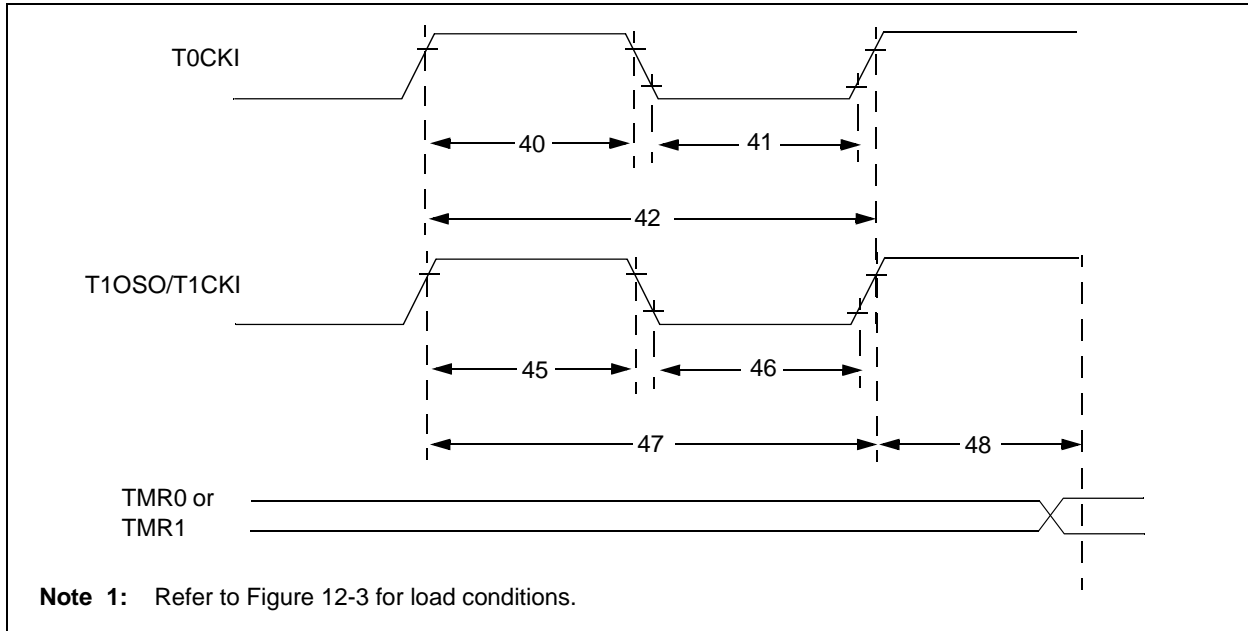
Param No.	Sym	Characteristic	Min	Typ†	Max	Units	Conditions
30	TMCLR	MCLR Pulse Width (low)	2	—	—	μs	VDD = 5V, -40°C to +125°C
31*	TWDT	Watchdog Timer Time-out Period (No Prescaler)	7	18	33	ms	VDD = 5V, -40°C to +85°C
			TBD	TBD	TBD	ms	VDD = 5V, +85°C to +125°C
32	TOST	Oscillation Start-up Timer Period	—	1024 TOSC	—	—	TOSC = OSC1 period
33*	TPWRT	Power-up Timer Period	28	72	132	ms	VDD = 5V, -40°C to +85°C
			TBD	TBD	TBD	ms	VDD = 5V, +85°C to +125°C
34	TIOZ	I/O high-impedance from MCLR Low or WDT Reset	—	—	2.1	μs	
35	TBOR	Brown-out Reset Pulse Width	100	—	—	μs	VDD ≤ BVDD (D005)

\* These parameters are characterized but not tested.

† Data in "Typ" column is at 5V, 25°C unless otherwise stated. These parameters are for design guidance only and are not tested.

# PIC16F716

**FIGURE 12-8: TIMER0 AND TIMER1 EXTERNAL CLOCK TIMINGS<sup>(1)</sup>**



**TABLE 12-5: TIMER0 AND TIMER1 EXTERNAL CLOCK REQUIREMENTS**

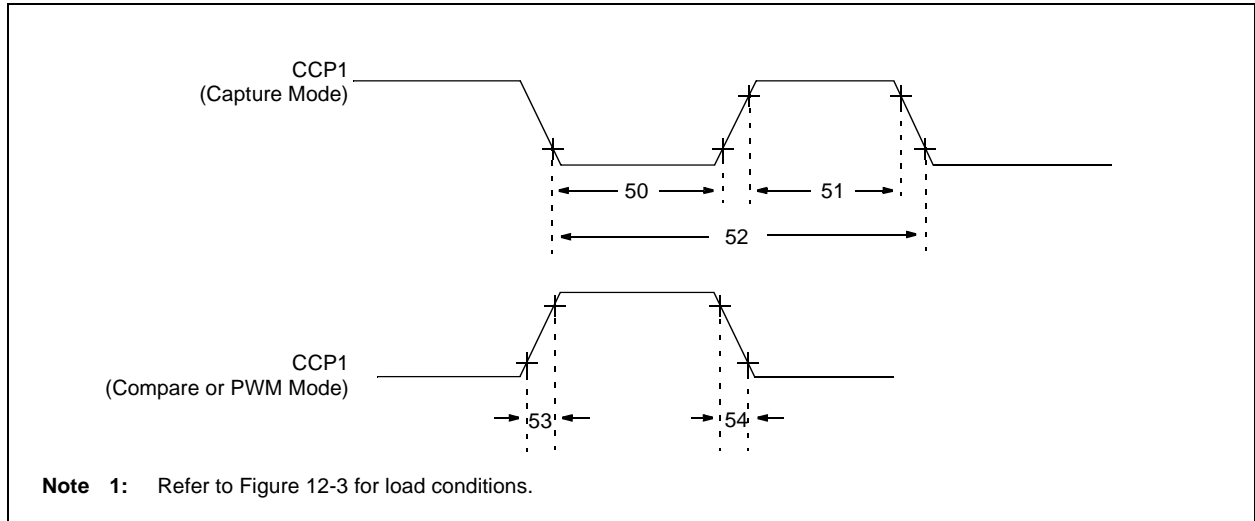
Param No.	Sym	Characteristic		Min	Typ†	Max	Units	Conditions
40*	Tt0H	T0CKI High Pulse Width		No Prescaler $0.5T_{CY} + 20$	—	—	ns	Must also meet parameter 42
				With Prescaler 10	—	—	ns	
41*	Tt0L	T0CKI Low Pulse Width		No Prescaler $0.5T_{CY} + 20$	—	—	ns	Must also meet parameter 42
				With Prescaler 10	—	—	ns	
42*	Tt0P	T0CKI Period		No Prescaler $T_{CY} + 40$	—	—	ns	N = prescale value (2, 4, ..., 256)
				With Prescaler Greater of: $20$ or $\frac{T_{CY} + 40}{N}$	—	—	ns	
45*	Tt1H	T1CKI High Time	Synchronous, Prescaler = 1	$0.5T_{CY} + 20$	—	—	ns	Must also meet parameter 47
			Synchronous, Prescaler = 2,4,8	15	—	—	ns	
			Asynchronous	30	—	—	ns	
46*	Tt1L	T1CKI Low Time	Synchronous, Prescaler = 1	$0.5T_{CY} + 20$	—	—	ns	Must also meet parameter 47
			Synchronous, Prescaler = 2,4,8	15	—	—	ns	
			Asynchronous	30	—	—	ns	
47*	Tt1P	T1CKI input period	Synchronous	Greater of: $30$ OR $\frac{T_{CY} + 40}{N}$	—	—	ns	N = prescale value (1, 2, 4, 8)
			Asynchronous	60	—	—	ns	
	Ft1	Timer1 oscillator input frequency range (oscillator enabled by setting bit T1OSCEN)		32.768	—	32.768	kHz	
48*	TCKEZtmr1	Delay from external clock edge to timer increment		$2T_{osc}$	—	$7T_{osc}$	—	

\* These parameters are characterized but not tested.

† Data in "Typ" column is at 5V, 25°C unless otherwise stated. These parameters are for design guidance only and are not tested.



**FIGURE 12-9: CAPTURE/COMPARE/PWM TIMINGS<sup>(1)</sup>**



**TABLE 12-6: CAPTURE/COMPARE/PWM REQUIREMENTS**

Param No.	Sym	Characteristic		Min	Typ †	Max	Units	Conditions
50*	TccL	CCP1 input low time	No Prescaler	$0.5T_{CY} + 20$	—	—	ns	
			With Prescaler   Standard	10	—	—	ns	
51*	TccH	CCP1 input high time	No Prescaler	$0.5T_{CY} + 20$	—	—	ns	
			With Prescaler   Standard	10	—	—	ns	
52*	TccP	CCP1 input period		$\frac{3T_{CY} + 40}{N}$	—	—	ns	N = prescale value (1, 4, or 16)
53*	TccR	CCP1 output rise time	Standard	—	10	40	ns	
53A*			Extended	—	—	80	ns	
54*	TccF	CCP1 output fall time	Standard	—	10	40	ns	
54A*			Extended	—	—	80	ns	

\* These parameters are characterized but not tested.

† Data in "Typ" column is at 5V, 25°C unless otherwise stated. These parameters are for design guidance only and are not tested.

# PIC16F716

**TABLE 12-7: A/D CONVERTER CHARACTERISTICS: PIC16F716 (INDUSTRIAL, EXTENDED)**

Para m No.	Sym	Characteristic	Min	Typ†	Max	Units	Conditions
A00	VDD	VDD Operation	2.5	—	5.5	V	
A01	NR	Resolution	—	—	8-bits	bit	VREF = VDD = 5.12V, VSS ≤ VAIN ≤ VREF
A02	EABS	Total Absolute error	—	—	< ± 1	LSb	VREF = VDD = 5.12V, VSS ≤ VAIN ≤ VREF
A03	EIL	Integral linearity error	—	—	< ± 1	LSb	VREF = VDD = 5.12V, VSS ≤ VAIN ≤ VREF
A04	EDL	Differential linearity error	—	—	< ± 1	LSb	VREF = VDD = 5.12V, VSS ≤ VAIN ≤ VREF
A05	EFS	Full scale error	—	—	< ± 1	LSb	VREF = VDD = 5.12V, VSS ≤ VAIN ≤ VREF
A06	E0FF	Offset error	—	—	< ± 1	LSb	VREF = VDD = 5.12V, VSS ≤ VAIN ≤ VREF
A10	—	Monotonicity	—	guaranteed <sup>(3)</sup>	—	—	VSS ≤ VAIN ≤ VREF
A20	VREF	Reference voltage	2.5V	—	VDD + 0.3	V	
A25	VAIN	Analog input voltage	VSS - 0.3	—	VREF + 0.3	V	
A30	ZAIN	Recommended impedance of analog voltage source	—	—	10.0	kΩ	
A40	IAD	A/D conversion current (VDD)	Standard	180	—	μA	Average current consumption when A/D is on. <sup>(1)</sup>
A50	IREF	VREF input current <sup>(2)</sup>	10	—	1000	μA	During VAIN acquisition. Based on differential of VHOLD to VAIN to charge CHOLD, see <b>Section 12.1 “DC Characteristics: PIC16F716 (Industrial, Extended)”</b> . During A/D Conversion cycle
			—	—	10	μA	

\* These parameters are characterized but not tested.

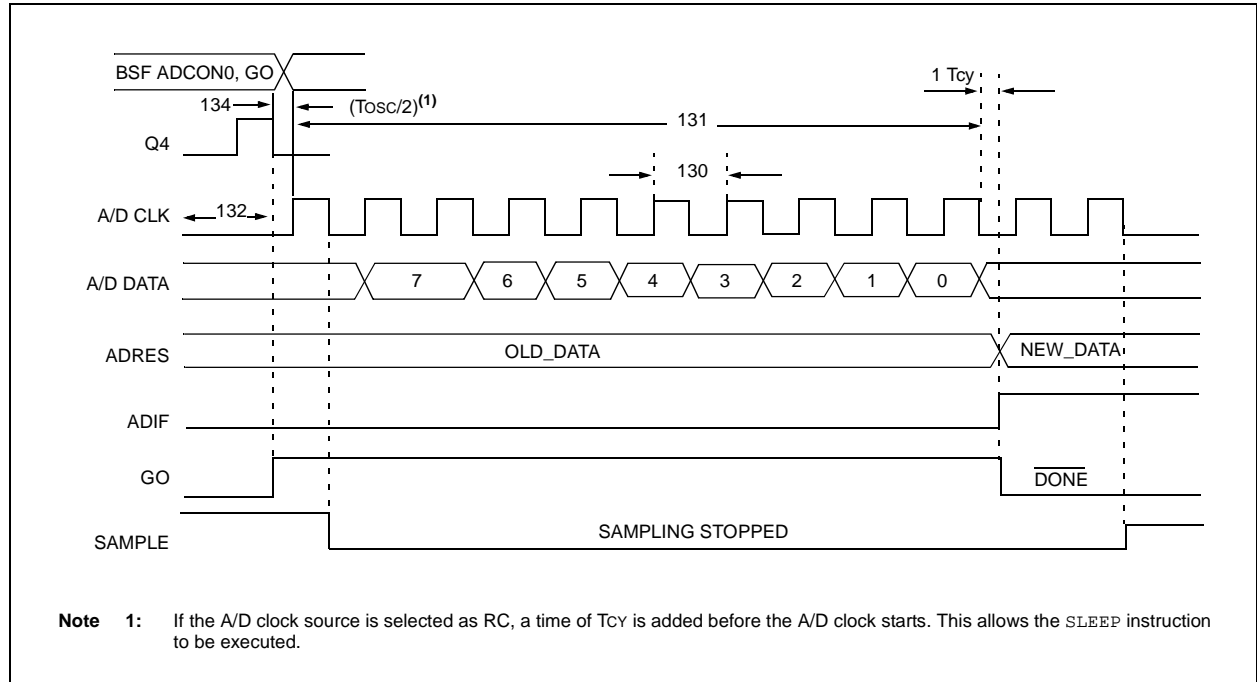
† Data in “Typ” column is at 5V, 25°C unless otherwise stated. These parameters are for design guidance only and are not tested.

**Note 1:** When A/D is off, it will not consume any current other than minor leakage current. The power-down current spec includes any such leakage from the A/D module.

**2:** VREF current is from RA3 pin or VDD pin, whichever is selected as reference input.

**3:** The A/D conversion result never decreases with an increase in the input voltage, and has no missing codes.

**FIGURE 12-10: A/D CONVERSION TIMING**



**TABLE 12-8: A/D CONVERSION REQUIREMENTS**

Param No.	Sym	Characteristic		Min	Typ†	Max	Units	Conditions
130	TAD	A/D clock period	Industrial	1.6	—	—	$\mu$ s	TOSC based, $V_{REF} \geq 3.0V$
			Industrial	1.6	4.0	6.0	$\mu$ s	A/D RC mode
			Extended	1.6	—	—	$\mu$ s	TOSC based, $V_{REF} \geq 3.0V$
			Extended	1.6	6.0	9.0	$\mu$ s	A/D RC mode
131	Tcnv	Conversion time (not including S/H time) <sup>(1)</sup>	9.5	—	9.5	TAD		
132	TACQ	Acquisition time	(Note 2)	20	—	$\mu$ s	The minimum time is the amplifier settling time. This may be used if the "new" input voltage has not changed by more than 1 LSB (i.e., 20.0 mV @ 5.12V) from the last sampled voltage (as stated on CHOLD).	
			5*	—	$\mu$ s			
134	TGO	Q4 to A/D clock start	—	Tosc/2 **	—	—	If the A/D clock source is selected as RC, a time of $T_{CY}$ is added before the A/D clock starts. This allows the <code>SLEEP</code> instruction to be executed.	
135	Tswc	Switching from convert $\rightarrow$ sample time	1.5 **	—	—	TAD		

\* These parameters are characterized but not tested.

\*\* This specification ensured by design.

† Data in "Typ" column is at 5V, 25°C unless otherwise stated. These parameters are for design guidance only and are not tested.

**Note 1:** ADRES register may be read on the following  $T_{CY}$  cycle.

**Note 2:** See Section 12.1 "DC Characteristics: PIC16F716 (Industrial, Extended)" for min. conditions.

# PIC16F716

---

NOTES:

## 13.0 DC AND AC CHARACTERISTICS GRAPHS AND TABLES

The graphs and tables provided in this section are for **design guidance** and are **not tested**.

In some graphs or tables, the data presented are **outside specified operating range** (i.e., outside specified  $V_{DD}$  range). This is for **information only** and devices will operate properly only within the specified range.

The data presented in this section is a **statistical summary** of data collected on units from different lots over a period of time and matrix samples. 'Typical' represents the mean of the distribution at 25°C. 'Max' or 'min' represents  $(\text{mean} + 3\sigma)$  or  $(\text{mean} - 3\sigma)$  respectively, where  $\sigma$  is standard deviation, over the whole temperature range.

**Graphs and Tables not available at this time.**

# PIC16F716

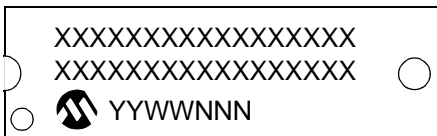
---

NOTES:

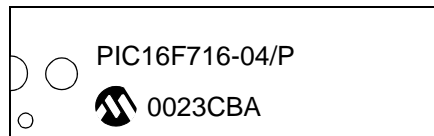
## 14.0 PACKAGING INFORMATION

### 14.1 Package Marking Information

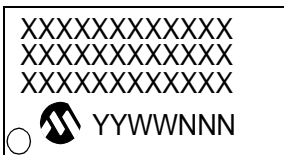
#### 18-Lead PDIP



#### Example



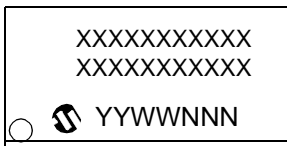
#### 18-Lead SOIC



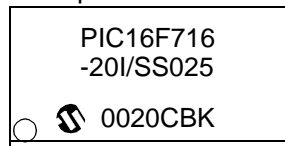
#### Example



#### 20-Lead SSOP



#### Example



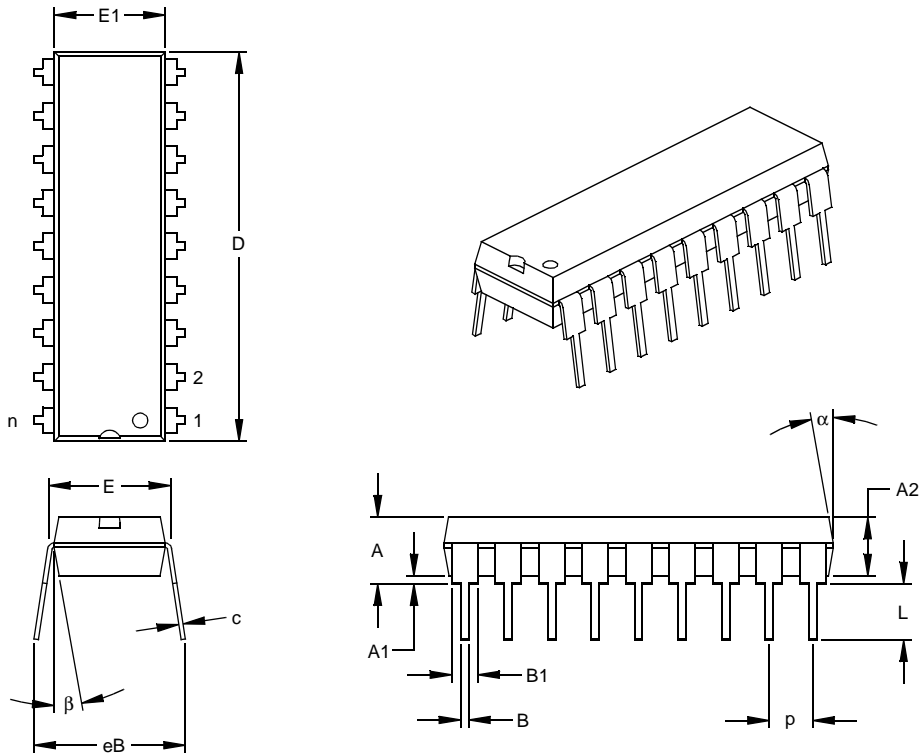
**Legend:** XX...X Customer specific information\*  
 Y Year code (last digit of calendar year)  
 YY Year code (last 2 digits of calendar year)  
 WW Week code (week of January 1 is week '01')  
 NNN Alphanumeric traceability code

**Note:** In the event the full Microchip part number cannot be marked on one line, it will be carried over to the next line thus limiting the number of available characters for customer specific information.

\* Standard PICmicro device marking consists of Microchip part number, year code, week code, and traceability code. For PICmicro device marking beyond this, certain price adders apply. Please check with your Microchip Sales Office. For QTP devices, any special marking adders are included in QTP price.

# PIC16F716

## 18-Lead Plastic Dual In-line (P) – 300 mil (PDIP)



Units		INCHES*			MILLIMETERS		
Dimension Limits		MIN	NOM	MAX	MIN	NOM	MAX
Number of Pins	n		18			18	
Pitch	p		.100			2.54	
Top to Seating Plane	A	.140	.155	.170	3.56	3.94	4.32
Molded Package Thickness	A2	.115	.130	.145	2.92	3.30	3.68
Base to Seating Plane	A1	.015			0.38		
Shoulder to Shoulder Width	E	.300	.313	.325	7.62	7.94	8.26
Molded Package Width	E1	.240	.250	.260	6.10	6.35	6.60
Overall Length	D	.890	.898	.905	22.61	22.80	22.99
Tip to Seating Plane	L	.125	.130	.135	3.18	3.30	3.43
Lead Thickness	c	.008	.012	.015	0.20	0.29	0.38
Upper Lead Width	B1	.045	.058	.070	1.14	1.46	1.78
Lower Lead Width	B	.014	.018	.022	0.36	0.46	0.56
Overall Row Spacing	§ eB	.310	.370	.430	7.87	9.40	10.92
Mold Draft Angle Top	α	5	10	15	5	10	15
Mold Draft Angle Bottom	β	5	10	15	5	10	15

\* Controlling Parameter

§ Significant Characteristic

Notes:

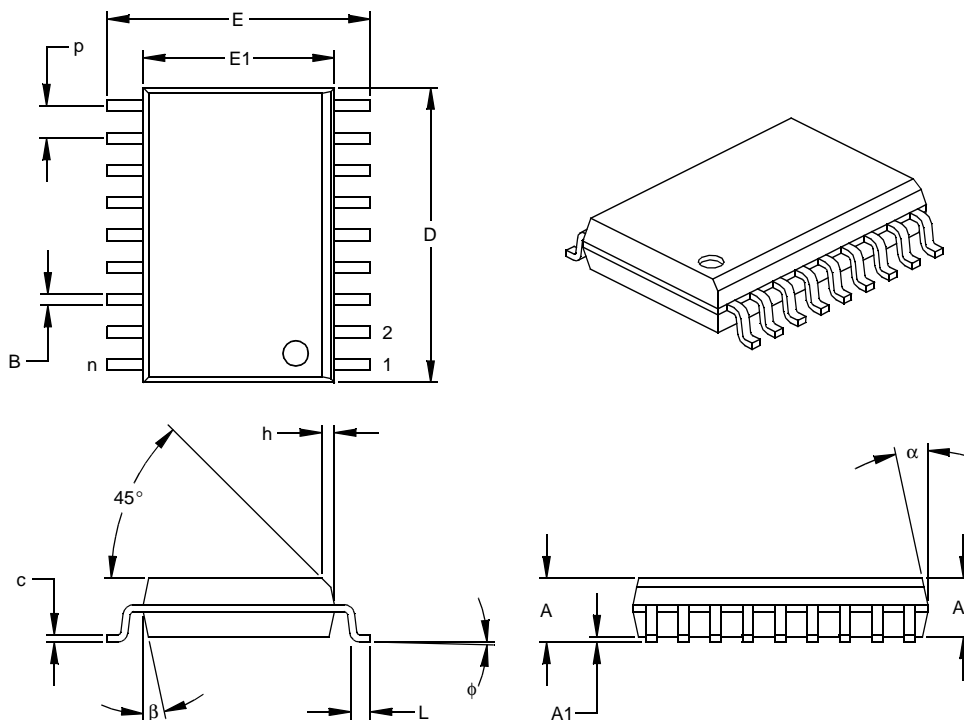
Dimensions D and E1 do not include mold flash or protrusions. Mold flash or protrusions shall not exceed .010" (0.254mm) per side.

JEDEC Equivalent: MS-001

Drawing No. C04-007



## 18-Lead Plastic Small Outline (SO) – Wide, 300 mil (SOIC)



Dimension Limits	Units	INCHES*			MILLIMETERS		
		MIN	NOM	MAX	MIN	NOM	MAX
Number of Pins	n		18			18	
Pitch	p		.050			1.27	
Overall Height	A	.093	.099	.104	2.36	2.50	2.64
Molded Package Thickness	A2	.088	.091	.094	2.24	2.31	2.39
Standoff §	A1	.004	.008	.012	0.10	0.20	0.30
Overall Width	E	.394	.407	.420	10.01	10.34	10.67
Molded Package Width	E1	.291	.295	.299	7.39	7.49	7.59
Overall Length	D	.446	.454	.462	11.33	11.53	11.73
Chamfer Distance	h	.010	.020	.029	0.25	0.50	0.74
Foot Length	L	.016	.033	.050	0.41	0.84	1.27
Foot Angle	φ	0	4	8	0	4	8
Lead Thickness	c	.009	.011	.012	0.23	0.27	0.30
Lead Width	B	.014	.017	.020	0.36	0.42	0.51
Mold Draft Angle Top	α	0	12	15	0	12	15
Mold Draft Angle Bottom	β	0	12	15	0	12	15

\* Controlling Parameter  
 § Significant Characteristic

Notes:

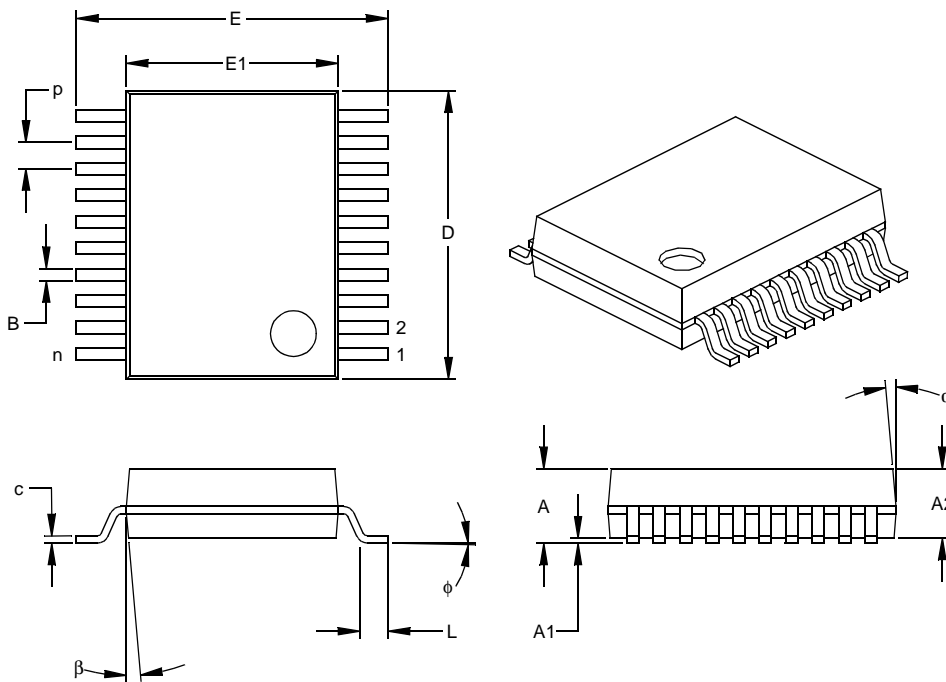
Dimensions D and E1 do not include mold flash or protrusions. Mold flash or protrusions shall not exceed .010" (0.254mm) per side.

JEDEC Equivalent: MS-013

Drawing No. C04-051

# PIC16F716

## 20-Lead Plastic Shrink Small Outline (SS) – 209 mil, 5.30 mm (SSOP)



Units		INCHES*			MILLIMETERS		
Dimension Limits		MIN	NOM	MAX	MIN	NOM	MAX
Number of Pins	n		20			20	
Pitch	p		.026			0.65	
Overall Height	A	.068	.073	.078	1.73	1.85	1.98
Molded Package Thickness	A2	.064	.068	.072	1.63	1.73	1.83
Standoff §	A1	.002	.006	.010	0.05	0.15	0.25
Overall Width	E	.299	.309	.322	7.59	7.85	8.18
Molded Package Width	E1	.201	.207	.212	5.11	5.25	5.38
Overall Length	D	.278	.284	.289	7.06	7.20	7.34
Foot Length	L	.022	.030	.037	0.56	0.75	0.94
Lead Thickness	c	.004	.007	.010	0.10	0.18	0.25
Foot Angle	φ	0	4	8	0.00	101.60	203.20
Lead Width	B	.010	.013	.015	0.25	0.32	0.38
Mold Draft Angle Top	α	0	5	10	0	5	10
Mold Draft Angle Bottom	β	0	5	10	0	5	10

\* Controlling Parameter

§ Significant Characteristic

Notes:

Dimensions D and E1 do not include mold flash or protrusions. Mold flash or protrusions shall not exceed .010" (0.254mm) per side.

JEDEC Equivalent: MO-150

Drawing No. C04-072

## **APPENDIX A: REVISION HISTORY**

### **Revision A (June 2003)**

Original data sheet. However, the device described in this data sheet are upgrades to PIC16C716.

## **APPENDIX B: CONVERSION CONSIDERATIONS**

This is a Flash program memory version of the PIC16C716 device. Refer to the migration document, DS40059, for more information about differences between the PIC16F716 and PIC16C716.

# PIC16F716

## APPENDIX C: MIGRATION FROM BASE-LINE TO MID-RANGE DEVICES

This section discusses how to migrate from a baseline device (i.e., PIC16C5X) to a mid-range device (i.e., PIC16F716).

The following are the list of modifications over the PIC16C5X microcontroller family:

1. Instruction word length is increased to 14-bits. This allows larger page sizes both in program memory (2K now as opposed to 512 before) and register file (128 bytes now versus 32 bytes before).
2. A PC high latch register (PCLATH) is added to handle program memory paging. Bits PA2, PA1, PA0 are removed from Status register.
3. Data memory paging is redefined slightly. Status register is modified.
4. Four new instructions have been added: RETURN, RETFIE, ADDLW, and SUBLW. Two instructions TRIS and OPTION are being phased out although they are kept for compatibility with PIC16C5X.
5. OPTION\_REG and TRIS registers are made addressable.
6. Interrupt capability is added. Interrupt vector is at 0004h.
7. Stack size is increased to 8 deep.
8. Reset vector is changed to 0000h.
9. Reset of all registers is revisited. Five different Reset (and wake-up) types are recognized. Registers are reset differently.
10. Wake-up from Sleep through interrupt is added.
11. Two separate timers, Oscillator Start-up Timer (OST) and Power-up Timer (PWRT) are included for more reliable power-up. These timers are invoked selectively to avoid unnecessary delays on power-up and wake-up.
12. PORTB has weak pull-ups and interrupt-on-change feature.
13. T0CKI pin is also a port pin (RA4) now.
14. FSR is made a full eight bit register.
15. "In-circuit serial programming" is made possible. The user can program PIC16F716 devices using only five pins: VDD, VSS, MCLR/VPP, RB6 (clock) and RB7 (data in/out).
16. PCON status register is added with a Power-on Reset Status bit (POR).
17. Brown-out protection circuitry has been added. Controlled by configuration word bits BOREN and BORV. Brown-out Reset ensures the device is placed in a Reset condition if VDD dips below a fixed setpoint.

To convert code written for PIC16C5X to PIC16F716, the user should take the following steps:

1. Remove any program memory page select operations (PA2, PA1, PA0 bits) for CALL, GOTO.
2. Revisit any computed jump operations (write to PC or add to PC, etc.) to make sure page bits are set properly under the new scheme.
3. Eliminate any data memory page switching. Redefine data variables to reallocate them.
4. Verify all writes to Status, Option, and FSR registers since these have changed.
5. Change Reset vector to 0000h

**Note 1:** This device has been designed to perform to the parameters of its data sheet. It has been tested to an electrical specification designed to determine its conformance with these parameters. Due to process differences in the manufacture of this device, this device may have different performance characteristics than its earlier version. These differences may cause this device to perform differently in your application than the earlier version of this device.

- 2: The user should verify that the device oscillator starts and performs as expected. Adjusting the loading capacitor values and/or the Oscillator mode may be required.

## ON-LINE SUPPORT

Microchip provides on-line support on the Microchip World Wide Web site.

The web site is used by Microchip as a means to make files and information easily available to customers. To view the site, the user must have access to the Internet and a web browser, such as Netscape® or Microsoft® Internet Explorer. Files are also available for FTP download from our FTP site.

### Connecting to the Microchip Internet Web Site

The Microchip web site is available at the following URL:

**[www.microchip.com](http://www.microchip.com)**

The file transfer site is available by using an FTP service to connect to:

**<ftp://ftp.microchip.com>**

The web site and file transfer site provide a variety of services. Users may download files for the latest Development Tools, Data Sheets, Application Notes, User's Guides, Articles and Sample Programs. A variety of Microchip specific business information is also available, including listings of Microchip sales offices, distributors and factory representatives. Other data available for consideration is:

- Latest Microchip Press Releases
- Technical Support Section with Frequently Asked Questions
- Design Tips
- Device Errata
- Job Postings
- Microchip Consultant Program Member Listing
- Links to other useful web sites related to Microchip Products
- Conferences for products, Development Systems, technical information and more
- Listing of seminars and events

## SYSTEMS INFORMATION AND UPGRADE HOT LINE

The Systems Information and Upgrade Line provides system users a listing of the latest versions of all of Microchip's development systems software products. Plus, this line provides information on how customers can receive the most current upgrade kits. The Hot Line Numbers are:

1-800-755-2345 for U.S. and most of Canada, and

1-480-792-7302 for the rest of the world.

042003

# PIC16F716

---

---

## READER RESPONSE

It is our intention to provide you with the best documentation possible to ensure successful use of your Microchip product. If you wish to provide your comments on organization, clarity, subject matter, and ways in which our documentation can better serve you, please FAX your comments to the Technical Publications Manager at (480) 792-4150.

Please list the following information, and use this outline to provide us with your comments about this document.

To: Technical Publications Manager  
RE: Reader Response  
Total Pages Sent \_\_\_\_\_

From: Name \_\_\_\_\_  
Company \_\_\_\_\_  
Address \_\_\_\_\_  
City / State / ZIP / Country \_\_\_\_\_  
Telephone: (\_\_\_\_\_) \_\_\_\_\_ - \_\_\_\_\_ FAX: (\_\_\_\_\_) \_\_\_\_\_ - \_\_\_\_\_

Application (optional):

Would you like a reply? \_\_\_Y \_\_\_N

Device: PIC16F716

Literature Number: DS41206A

Questions:

1. What are the best features of this document?

---

---

2. How does this document meet your hardware and software development needs?

---

---

3. Do you find the organization of this document easy to follow? If not, why?

---

---

4. What additions to the document do you think would enhance the structure and subject?

---

---

5. What deletions from the document could be made without affecting the overall usefulness?

---

---

6. Is there any incorrect or misleading information (what and where)?

---

---

7. How would you improve this document?

---

---

## INDEX

### A

A/D	49
A/D Converter Enable (ADIE Bit)	14
A/D Converter Flag (ADIF Bit)	15, 50
A/D Converter Interrupt, Configuring	50
ADCON0 Register	9, 49
ADCON1 Register	10, 50
ADRES Register	9
Analog Port Pins, Configuring	52
Channel Select (CHS2:CHS0 Bits)	49
Clock Select (ADCS1:ADCS0 Bits)	49
Configuring the Module	50
Conversion Clock (Tad)	52
Conversion Status (GO/DONE Bit)	49, 50
Conversions	53
Converter Characteristics	104
Module On/Off (ADON Bit)	49
Port Configuration Control (PCFG2:PCFG0 Bits)	50
Sampling Requirements	51
Special Event Trigger (CCP)	35, 53
Timing Diagram	105
Absolute Maximum Ratings	91
ADCON0 Register	9
ADCON1 Register	10
ADDLW Instruction	73
ADDWF Instruction	73
ADRES Register	9
Analog Input Model	51
Analog-to-Digital Converter. <i>See</i> A/D	
ANDLW Instruction	73
ANDWF Instruction	73
Assembler	
MPASM Assembler	85
<b>B</b>	
Banking, Data Memory	7, 11
BCF Instruction	74
Block Diagrams	
A/D	51
Capture (CCP Module)	34
Compare (CCP Module)	35
Interrupt Sources	65
On-Chip Reset Circuit	60
PIC16F716	5
PORTA	19, 20
PORTB	21
PWM (CCP Module)	36
PWM (Enhanced)	38
RB1/T1OSO/T1CKI	22
RB2/T1OSI	22
RB3/CCP1/P1A	23
RB4	23
RB5	24
RB6/P1C	24
RB7/P1D	25
Timer0	27
Timer0/WDT Prescaler	28
Timer1	30
Timer2	32
Watchdog Timer (WDT)	67
BOR. <i>See</i> Brown-out Reset	
Brown-out Detect (BOD)	59
Brown-out Reset (BOR)	55, 58, 62, 63

BOR Enable (BODEN Bit)	56
BOR Status (BOR Bit)	16
Timing Diagram	101
BSF Instruction	74
BTFSC Instruction	74
BTFSS Instruction	75
<b>C</b>	
C Compilers	
MPLAB C17	86
MPLAB C18	86
MPLAB C30	86
CALL Instruction	75
Capture (CCP Module)	34
CCP Pin Configuration	34
CCPR1H:CCPR1L Registers	34
Software Interrupt	34
Timer1 Mode Selection	34
Capture/Compare/PWM (CCP)	33
Capture Mode. <i>See</i> Capture	
CCP1CON Register	9
CCPR1H Register	9, 33
CCPR1L Register	9, 33
Compare Mode. <i>See</i> Compare	
Enable (CCP1IE Bit)	14
Flag (CCP1IF Bit)	15
PWM Mode. <i>See</i> PWM	
Timer Resources	33
Timing Diagram	103
CLRF Instruction	75
CLRWF Instruction	76
CLRWDI Instruction	76
Code Examples	
Capture (CCP Module)	
Changing Between Capture Prescalers	34
How to Clear RAM Using Indirect Addressing	18
Initializing PORTA	19
Initializing PORTB	21
Code Protection	55, 69
CP1:CP0 Bits	56
COMF Instruction	76
Compare (CCP Module)	34
CCP Pin Configuration	35
Software Interrupt	35
Special Event Trigger	30, 35, 53
Timer1 Mode Selection	35
Configuration Bits	55
Conversion Considerations	113
<b>D</b>	
Data Memory	7
Bank Select (RP1:RP0 Bits)	7, 11
General Purpose Registers	8
Register File Map	8
Special Function Registers	9
DC Characteristics	93, 94, 95, 96
DECF Instruction	76
DECFSZ Instruction	77
Demonstration Boards	
PICDEM 1	88
PICDEM 17	88
PICDEM 18R PIC18C601/801	89
PICDEM 2 Plus	88
PICDEM 3 PIC16C92X	88

# PIC16F716

PICDEM 4 .....	88	SUBWF .....	83
PICDEM LIN PIC16C43X .....	89	SWAPF .....	83
PICDEM USB PIC16C7X5 .....	89	TRIS .....	83
PICDEM.net Internet/Ethernet .....	88	XORLW .....	84
Development Support .....	85	XORWF .....	84
Direct Addressing .....	18	Instruction Set Summary .....	71
<b>E</b>		INT Interrupt (RB0/INT). See Interrupt Sources	
ECCP		INTCON Register .....	9, 13
Auto-Shutdown .....	45	GIE Bit .....	13
and Automatic Restart .....	47	INTE Bit .....	13
Start-up Considerations .....	47	INTF Bit .....	13
Electrical Characteristics .....	91	PEIE Bit .....	13
Enhanced Capture/Compare/PWM (ECCP)		RBIE Bit .....	13
PWM Mode. See PWM (ECCP Module)		RBIF Bit .....	13
Enhanced CCP Auto-Shutdown .....	45	TOIE Bit .....	13
Enhanced PWM Mode. See PWM (ECCP Module) .....	38	T0IF Bit .....	13
Errata .....	3	Interrupt Sources .....	55, 65
Evaluation and Programming Tools .....	89	A/D Conversion Complete .....	50
External Power-on Reset Circuit .....	58	Capture Complete (CCP) .....	34
		Compare Complete (CCP) .....	35
<b>G</b>		Interrupt-on-Change (RB7:RB4) .....	21
GOTO Instruction .....	77	RB0/INT Pin, External .....	66
		TMR0 Overflow .....	28, 66
<b>I</b>		TMR1 Overflow .....	29, 30
I/O Ports .....	19	TMR2 to PR2 Match .....	32
ID Locations .....	55, 69	TMR2 to PR2 Match (PWM) .....	31, 36
INCF Instruction .....	78	Interrupts, Context Saving During .....	66
INCFSZ Instruction .....	78	Interrupts, Enable Bits	
In-Circuit Serial Programming (ICSP) .....	55, 69	A/D Converter Enable (ADIE Bit) .....	14
Indirect Addressing .....	18	CCP1 Enable (CCP1IE Bit) .....	14, 34
FSR Register .....	8, 9, 18	Global Interrupt Enable (GIE Bit) .....	13, 65
INDF Register .....	9	Interrupt-on-Change (RB7:RB4) Enable (RBIE Bit) .....	13, 66
Instruction Set		Peripheral Interrupt Enable (PEIE Bit) .....	13
ADDLW .....	73	RB0/INT Enable (INTE Bit) .....	13
ADDWF .....	73	TMR0 Overflow Enable (TOIE Bit) .....	13
ANDLW .....	73	TMR1 Overflow Enable (TMR1IE Bit) .....	14
ANDWF .....	73	TMR2 to PR2 Match Enable (TMR2IE Bit) .....	14
BCF .....	74	Interrupts, Flag Bits	
BSF .....	74	A/D Converter Flag (ADIF Bit) .....	15, 50
BTFSC .....	74	CCP1 Flag (CCP1IF Bit) .....	15, 34
BTFSS .....	75	Interrupt-on-Change (RB7:RB4) Flag (RBIF Bit) ..	13, 66
CALL .....	75	RB0/INT Flag (INTF Bit) .....	13
CLRF .....	75	TMR0 Overflow Flag (T0IF Bit) .....	13, 66
CLRWF .....	76	TMR1 Overflow Flag (TMR1IF Bit) .....	15
CLRWDT .....	76	TMR2 to PR2 Match Flag (TMR2IF Bit) .....	15
COMF .....	76	IORLW Instruction .....	79
DECF .....	76	IORWF Instruction .....	79
DECFSZ .....	77	<b>M</b>	
GOTO .....	77	Master Clear ( $\overline{\text{MCLR}}$ )	
INCF .....	78	$\overline{\text{MCLR}}$ Reset, Normal Operation .....	58, 62, 63
INCFSZ .....	78	$\overline{\text{MCLR}}$ Reset, Sleep .....	58, 62, 63
IORLW .....	79	Memory Organization	
IORWF .....	79	Data Memory .....	7
MOVF .....	79	Program Memory .....	7
MOVLW .....	79	Migration from Base-Line to Mid-Range Devices .....	114
MOVWF .....	80	MOVF Instruction .....	79
NOP .....	80	MOVLW Instruction .....	79
OPTION .....	80	MOVWF Instruction .....	80
RETFIE .....	80	MPLAB ASM30 Assembler, Linker, Librarian .....	86
RETLW .....	81	MPLAB ICD 2 In-Circuit Debugger .....	87
RETURN .....	81	MPLAB ICE 2000 High Performance Universal	
RLF .....	81	In-Circuit Emulator .....	87
RRF .....	82	MPLAB ICE 4000 High Performance Universal	
SLEEP .....	82	In-Circuit Emulator .....	87
SUBLW .....	82		



MPLAB Integrated Development Environment Software ....	85	POR Status ( $\overline{\text{POR}}$ Bit) .....	16
MPLINK Object Linker/MPLIB Object Librarian .....	86	Power Control (PCON) Register .....	62
<b>N</b>			
NOP Instruction .....	80	Power-down (PD Bit) .....	11, 58
<b>O</b>			
OPTION Instruction .....	80	Power-on Reset Circuit, External .....	58
OPTION_REG Register .....	10, 12	Power-up Timer (PWRT) .....	55, 59
INTEDG Bit .....	12	PWRT Enable (PWRTE Bit) .....	56
PS2:PS0 Bits .....	12, 27	Time-out ( $\overline{\text{TO}}$ Bit) .....	11, 58
PSA Bit .....	12, 27	Time-out Sequence .....	62
RBPU Bit .....	12	Time-out Sequence on Power-up .....	64
T0CS Bit .....	12, 27	Timing Diagram .....	101
T0SE Bit .....	12, 27	Prescaler, Capture .....	34
Oscillator Configuration .....	55, 57	Prescaler, Timer0 .....	27
HS .....	57, 62	Assignment (PSA Bit) .....	12, 27
LP .....	57, 62	Rate Select (PS2:PS0 Bits) .....	12, 27
RC .....	57, 58, 62	Switching Between Timer0 and WDT .....	28
Selection (FOSC1:FOSC0 Bits) .....	56	Prescaler, Timer1 .....	30
XT .....	57, 62	Select (T1CKPS1:T1CKPS0 Bits) .....	29
Oscillator, Timer1 .....	29, 30	Prescaler, Timer2 .....	37
Oscillator, WDT .....	67	Select (T2CKPS1:T2CKPS0 Bits) .....	31
<b>P</b>			
Packaging .....	109	PRO MATE II Universal Device Programmer .....	87
Paging, Program Memory .....	7, 17	Program Counter	
PCON Register .....	16, 62	PCL Register .....	9, 17
BOR Bit .....	16	PCLATH Register .....	9, 17, 66
POR Bit .....	16	Reset Conditions .....	62
PICKIT 1 FLASH Starter Kit .....	89	Program Memory .....	7
PICSTART Plus Development Programmer .....	87	Interrupt Vector .....	7
PIE1 Register .....	10, 14	Paging .....	7, 17
ADIE Bit .....	14	Program Memory Map .....	7
CCP1IE Bit .....	14	Reset Vector .....	7
TMR1IE Bit .....	14	Program Verification .....	69
TMR2IE Bit .....	14	PWM (CCP Module) .....	36
PIR1 Register .....	9, 15	CCPR1H:CCPR1L Registers .....	36
ADIF Bit .....	15	Duty Cycle .....	37
CCP1IF Bit .....	15	Example Frequencies/Resolutions .....	37
TMR1IF Bit .....	15	Output Diagram .....	36
TMR2IF Bit .....	15	Period .....	36
Pointer, FSR .....	18	Set-Up for PWM Operation .....	37
POR. See Power-on Reset		TMR2 to PR2 Match .....	31, 36
PORTA		TMR2 to PR2 Match Enable (TMR2IE Bit) .....	14
PORTA Register .....	9, 19	TMR2 to PR2 Match Flag (TMR2IF Bit) .....	15
TRISA Register .....	10, 19	PWM (ECCP Module) .....	38
PORTB		Associated Registers .....	48
PORTB Register .....	9, 21	Direction Change in Full-Bridge Output Mode .....	43
Pull-up Enable (RBPU Bit) .....	12	Effects of Reset .....	48
RB0/INT Edge Select (INTEDG Bit) .....	12	Full-Bridge Application Example .....	43
RB0/INT Pin, External .....	66	Full-Bridge Mode .....	43
RB7:RB4 Interrupt-on-Change .....	66	Half-Bridge Mode .....	42
RB7:RB4 Interrupt-on-Change Enable		Half-Bridge Output Mode Applications Example .....	42
(RBIE Bit) .....	13, 66	Output Configurations .....	38
RB7:RB4 Interrupt-on-Change Flag (RBIF Bit) .....	66	Output Relationships (Active High and Low) .....	40
TRISB Register .....	10, 21	Output Relationships (Active-High and Low) .....	39
Postscaler, Timer2		Output Relationships Diagram .....	39, 41
Select (TOUTPS3:TOUTPS0 Bits) .....	31	Programmable Dead-band Delay .....	45
Postscaler, WDT .....	27	Setup for Operation .....	48
Assignment (PSA Bit) .....	12, 27	Shoot-through Current .....	45
Rate Select (PS2:PS0 Bits) .....	12, 27	Start-up Considerations .....	47
Switching Between Timer0 and WDT .....	28	<b>Q</b>	
Power-down Mode. See Sleep		Q-Clock .....	37, 100
Power-on Reset (POR) .....	55, 58, 62, 63		
Oscillator Start-up Timer (OST) .....	55, 59		

# PIC16F716

## R

RA3:RA0 .....	19
RA4/T0CKI Pin .....	20
RAM. See Data Memory.	
RB0 Pin .....	21
Register File .....	8
Register File Map .....	8
Registers	
A/D ADCON0 .....	49
A/D ADCON1 .....	49
A/D ADRES .....	49, 50
ADCON0 ADCS1:ADCS0 Bits .....	49
ADCON0 ADON Bit .....	49
ADCON0 CHS2:CHS0 Bits .....	49
ADCON0 GO/DONE Bit .....	49, 50
ADCON1 PCFG2:PCFG0 Bits .....	50
CCP1CON CCP1M3:CCP1M0 Bits .....	33
CCP1CON CCP1X:CCP1Y Bits .....	33
Compare (CCP Module)	
CCPR1H:CCPR1L .....	34
INTCON Register	
RBIF .....	21
PWM1CON (Enhanced PWM Configuration) .....	46
T1CON Register	
T1CKPS1:T1CKPS0 Bits .....	29
T1OSCN Bit .....	29
T1SYNC Bit .....	29
TMR1CS Bit .....	29
TMR1ON Bit .....	29
T2CON Register T2CKPS1:T2CKPS0 Bits .....	31
T2CON Register TMR2ON Bit .....	31
T2CON Register TOUTPS3:TOUTPS0 Bits .....	31
Timer2	
PR2 .....	36
Timer2 PR2 Register .....	31
Timer2 TMR2 Register .....	31
TMR1H Timer1 Register .....	29
TMR1L Timer1 Register .....	29
Reset .....	55, 58
Brown-out Reset (BOR). See Brown-out Reset (BOR)	
MCLR Reset. See MCLR	
Power-on Reset (POR). See Power-on Reset (POR)	
Reset Conditions for PCON Register .....	62
Reset Conditions for Program Counter .....	62
Reset Conditions for Status Register .....	62
Timing Diagram .....	101
WDT Reset. See Watchdog Timer (WDT)	
RETFIE Instruction .....	80
RETLW Instruction .....	81
RETURN Instruction .....	81
Revision History .....	113
RLF Instruction .....	81
RRF Instruction .....	82

## S

Shoot-through Current .....	45
Sleep .....	55, 58, 68
Sleep Instruction .....	82
Software Simulator (MPLAB SIM) .....	86
Software Simulator (MPLAB SIM30) .....	86
Special Event Trigger. See Compare	
Special Features of the CPU .....	55
Special Function Registers .....	9
Speed, Operating .....	1
Stack .....	17

Status Register .....	9, 66
C Bit .....	11
DC Bit .....	11
IRP Bit .....	11
PD Bit .....	11, 58
RP1:RP0 Bits .....	11
TO Bit .....	11, 58
Z Bit .....	11
SUBLW Instruction .....	82
SUBWF Instruction .....	83
SWAPF Instruction .....	83

## T

T1CON Register .....	9
T2CON Register .....	9
Timer0 .....	27
Clock Source Edge Select (TOSE Bit) .....	12, 27
Clock Source Select (T0CS Bit) .....	12, 27
Overflow Enable (TOIE Bit) .....	13
Overflow Flag (TOIF Bit) .....	13, 66
Overflow Interrupt .....	28, 66
Prescaler. See Prescaler, Timer0	
Timing Diagram .....	102
TMR0 Register .....	9
Timer1 .....	29
Clock Source Select (TMR1CS Bit) .....	29
External Clock Input Sync (T1SYNC Bit) .....	29
Module On/Off (TMR1ON Bit) .....	29
Oscillator .....	29, 30
Oscillator Enable (T1OSCN Bit) .....	29
Overflow Enable (TMR1IE Bit) .....	14
Overflow Flag (TMR1IF Bit) .....	15
Overflow Interrupt .....	29, 30
Prescaler. See Prescaler, Timer1	
Special Event Trigger (CCP) .....	30, 35
T1CON Register .....	9
Timing Diagram .....	102
TMR1H Register .....	9
TMR1L Register .....	9
Timer2 .....	
Postscaler. See Postscaler, Timer2	
PR2 Register .....	10
Prescaler. See Prescaler, Timer2	
T2CON Register .....	9
TMR2 Register .....	9
TMR2 to PR2 Match Enable (TMR2IE Bit) .....	14
TMR2 to PR2 Match Flag (TMR2IF Bit) .....	15
TMR2 to PR2 Match Interrupt .....	31, 32, 36
Timing Diagrams	
Half-Bridge PWM Output .....	42
PWM Auto-Shutdown (PRSEN = 0, Auto-Restart Disabled) .....	47
PWM Auto-Shutdown (PRSEN = 1, Auto-Restart Enabled) .....	47
PWM Direction Change .....	44
PWM Direction Change at Near 100% Duty Cycle .....	44
Time-out Sequence on Power-up .....	64
Wake-up from Sleep via Interrupt .....	69
Timing Diagrams and Specifications .....	98
A/D Conversion .....	105
Brown-out Reset (BOR) .....	101
Capture/Compare/PWM (CCP) .....	103
CLKOUT and I/O .....	100
External Clock .....	98
Oscillator Start-up Timer (OST) .....	101
Power-up Timer (PWRT) .....	101

Reset.....	101
Timer0 and Timer1.....	102
Watchdog Timer (WDT).....	101
TRIS Instruction .....	83

## W

W Register .....	66
Wake-up from Sleep .....	55, 68
Interrupts.....	62, 63
MCLR Reset .....	63
Timing Diagram.....	69
WDT Reset .....	63
Watchdog Timer (WDT) .....	55, 67
Enable (WDTE Bit).....	56, 67
Postscaler. See Postscaler, WDT	
Programming Considerations .....	67
RC Oscillator .....	67
Time-out Period .....	67
Timing Diagram.....	101
WDT Reset, Normal Operation .....	58, 62, 63
WDT Reset, Sleep .....	58, 62, 63
WWW, On-Line Support .....	3

## X

XORLW Instruction .....	84
XORWF Instruction .....	84

# PIC16F716

---

NOTES:

## PRODUCT IDENTIFICATION SYSTEM

To order or obtain information, e.g., on pricing or delivery, refer to the factory or the listed sales office.

<u>PART NO.</u>	<u>X</u>	<u>/XX</u>	<u>XXX</u>
Device	Temperature Range	Package	Pattern
Device	PIC16F716, PIC16F716T, VDD range 2.0V to 5.5V		
Temperature Range	I	= -40°C to +85°C (Industrial)	
	E	= -40°C to +125°C (Extended)	
Package	SO	= SOIC	
	P	= PDIP	
	SS	= SSOP	
Pattern	QTP, SQTP, Code or Special Requirements (blank otherwise)		

**Examples:**

a) PIC16F716 -I/P 301= Industrial temp., PDIP package, QTP pattern #301.

b) PIC16F716 - E/SO = Extended temp, SOIC package

**Note 1:** T = in tape and reel SOIC and SSOP packages only.

## Sales and Support

### Data Sheets

Products supported by a preliminary Data Sheet may have an errata sheet describing minor operational differences and recommended workarounds. To determine if an errata sheet exists for a particular device, please contact one of the following:

1. Your local Microchip sales office
2. The Microchip Corporate Literature Center U.S. FAX: (480) 792-7277
3. The Microchip Worldwide Site ([www.microchip.com](http://www.microchip.com))

Please specify which device, revision of silicon and Data Sheet (include Literature #) you are using.

### New Customer Notification System

Register on our web site ([www.microchip.com/cn](http://www.microchip.com/cn)) to receive the most current information on our products.



## WORLDWIDE SALES AND SERVICE

### AMERICAS

#### Corporate Office

2355 West Chandler Blvd.  
Chandler, AZ 85224-6199  
Tel: 480-792-7200  
Fax: 480-792-7277  
Technical Support: 480-792-7627  
Web Address: <http://www.microchip.com>

#### Atlanta

3780 Mansell Road, Suite 130  
Alpharetta, GA 30022  
Tel: 770-640-0034  
Fax: 770-640-0307

#### Boston

2 Lan Drive, Suite 120  
Westford, MA 01886  
Tel: 978-692-3848  
Fax: 978-692-3821

#### Chicago

333 Pierce Road, Suite 180  
Itasca, IL 60143  
Tel: 630-285-0071  
Fax: 630-285-0075

#### Dallas

4570 Westgrove Drive, Suite 160  
Addison, TX 75001  
Tel: 972-818-7423  
Fax: 972-818-2924

#### Detroit

Tri-Atria Office Building  
32255 Northwestern Highway, Suite 190  
Farmington Hills, MI 48334  
Tel: 248-538-2250  
Fax: 248-538-2260

#### Kokomo

2767 S. Albright Road  
Kokomo, IN 46902  
Tel: 765-864-8360  
Fax: 765-864-8387

#### Los Angeles

18201 Von Karman, Suite 1090  
Irvine, CA 92612  
Tel: 949-263-1888  
Fax: 949-263-1338

#### Phoenix

2355 West Chandler Blvd.  
Chandler, AZ 85224-6199  
Tel: 480-792-7966  
Fax: 480-792-4338

#### San Jose

2107 North First Street, Suite 590  
San Jose, CA 95131  
Tel: 408-436-7950  
Fax: 408-436-7955

#### Toronto

6285 Northam Drive, Suite 108  
Mississauga, Ontario L4V 1X5, Canada  
Tel: 905-673-0699  
Fax: 905-673-6509

### ASIA/PACIFIC

#### Australia

Suite 22, 41 Rawson Street  
Epping 2121, NSW  
Australia  
Tel: 61-2-9868-6733  
Fax: 61-2-9868-6755

#### China - Beijing

Unit 915  
Bei Hai Wan Tai Bldg.  
No. 6 Chaoyangmen Beidajie  
Beijing, 100027, No. China  
Tel: 86-10-85282100  
Fax: 86-10-85282104

#### China - Chengdu

Rm. 2401-2402, 24th Floor,  
Ming Xing Financial Tower  
No. 88 TIDU Street  
Chengdu 610016, China  
Tel: 86-28-86766200  
Fax: 86-28-86766599

#### China - Fuzhou

Unit 28F, World Trade Plaza  
No. 71 Wusi Road  
Fuzhou 350001, China  
Tel: 86-591-7503506  
Fax: 86-591-7503521

#### China - Hong Kong SAR

Unit 901-6, Tower 2, Metroplaza  
223 Hing Fong Road  
Kwai Fong, N.T., Hong Kong  
Tel: 852-2401-1200  
Fax: 852-2401-3431

#### China - Shanghai

Room 701, Bldg. B  
Far East International Plaza  
No. 317 Xian Xia Road  
Shanghai, 200051  
Tel: 86-21-6275-5700  
Fax: 86-21-6275-5060

#### China - Shenzhen

Rm. 1812, 18/F, Building A, United Plaza  
No. 5022 Binhe Road, Futian District  
Shenzhen 518033, China  
Tel: 86-755-82901380  
Fax: 86-755-8295-1393

#### China - Shunde

Room 401, Hongjian Building  
No. 2 Fengxiangnan Road, Ronggui Town  
Shunde City, Guangdong 528303, China  
Tel: 86-765-8395507 Fax: 86-765-8395571

#### China - Qingdao

Rm. B505A, Fullhope Plaza,  
No. 12 Hong Kong Central Rd.  
Qingdao 266071, China  
Tel: 86-532-5027355 Fax: 86-532-5027205

#### India

Divyasree Chambers  
1 Floor, Wing A (A3/A4)  
No. 11, O'Shaughnessey Road  
Bangalore, 560 025, India  
Tel: 91-80-2290061 Fax: 91-80-2290062

#### Japan

Benex S-1 6F  
3-18-20, Shinyokohama  
Kohoku-Ku, Yokohama-shi  
Kanagawa, 222-0033, Japan  
Tel: 81-45-471-6166 Fax: 81-45-471-6122

### Korea

168-1, Youngbo Bldg. 3 Floor  
Samsung-Dong, Kangnam-Ku  
Seoul, Korea 135-882  
Tel: 82-2-554-7200 Fax: 82-2-558-5932 or  
82-2-558-5934

### Singapore

200 Middle Road  
#07-02 Prime Centre  
Singapore, 188980  
Tel: 65-6334-8870 Fax: 65-6334-8850

### Taiwan

Kaohsiung Branch  
30F - 1 No. 8  
Min Chuan 2nd Road  
Kaohsiung 806, Taiwan  
Tel: 886-7-536-4818  
Fax: 886-7-536-4803

### Taiwan

Taiwan Branch  
11F-3, No. 207  
Tung Hua North Road  
Taipei, 105, Taiwan  
Tel: 886-2-2717-7175 Fax: 886-2-2545-0139

### EUROPE

#### Austria

Durisolstrasse 2  
A-4600 Wels  
Austria  
Tel: 43-7242-2244-399  
Fax: 43-7242-2244-393

#### Denmark

Regus Business Centre  
Lautrup høj 1-3  
Ballerup DK-2750 Denmark  
Tel: 45-4420-9895 Fax: 45-4420-9910

#### France

Parc d'Activite du Moulin de Massy  
43 Rue du Saule Trapu  
Batiment A - 1er Etage  
91300 Massy, France  
Tel: 33-1-69-53-63-20  
Fax: 33-1-69-30-90-79

#### Germany

Steinheilstrasse 10  
D-85737 Ismaning, Germany  
Tel: 49-89-627-144-0  
Fax: 49-89-627-144-44

#### Italy

Via Quasimodo, 12  
20025 Legnano (MI)  
Milan, Italy  
Tel: 39-0331-742611  
Fax: 39-0331-466781

#### Netherlands

P. A. De Biesbosch 14  
NL-5152 SC Drunen, Netherlands  
Tel: 31-416-690399  
Fax: 31-416-690340

#### United Kingdom

505 Eskdale Road  
Winkersham Triangle  
Wokingham  
Berkshire, England RG41 5TU  
Tel: 44-118-921-5869  
Fax: 44-118-921-5820

07/28/03