

1 Amp, WIDE INPUT RANGE, STEP-DOWN CONVERTER

Specifications refer to the standard application circuit at Ta: 25°C

Type: W 78 - xxx	3V3	Item No:	167803	5V0	Item No:	167805	9V0	Item No:	167809	12V	Item No:	167812	
Parameter:	Min.	Typ.	Max.	Min.	Typ.	Max.	Min.	Typ.	Max.	Min.	Typ.	Max.	Units
Input Voltage Range	5.5		34.0	7.0		34.0	11.0		34.0	15.0		34.0	V
Output Voltage	3.249		3.399	5.007		5.266	8.991		9.496	11.626		12.294	V
Line Voltage Regulation (Uin = min. to max. at 1A)		0.09	0.2		0.05	0.1		0.05	0.1		0.09	0.2	%
Load Regulation (0 to 1000 mA at Uin = 25V)		0.12	0.2		0.12	0.2		0.08	0.15		0.06	0.1	%
Transient Recovery Time (100% <-> 50% load)		150			150			150			150		µsec
Ripple & Noise (1000 mA)	7	15	20	7	18	27	7	18	39	7	18	45	mVp-p
Internal Power Dissipation (Uin = 34V at max. load)		835			833			830			828		mW
Quiescent Current	3.2		5.7	3.3		6.6	3.75		8.0	4.7		8.5	mA

All Types:													
Output Current	0		1000										mA
Output Current Limit	1200	1500	1800										mA
Current Limit Hiccup Time	13	16	20										ms
Temperature Coefficient		0.0115	0.012										%/°C
Switching Frequency	400	500	600										kHz
Undervoltage Lockout		5.3	5.5										V
Undervoltage Hysteresis		330											mV
Thermal Shutdown (internal junction temperature)	135	162											°C
Thermal Shutdown Hysteresis		14											°C
Operating Temperature Range	-40		+85										°C
Operating Junction Temperature Range	-40		+125										°C
Storage Temperature Range	-40		+125										°C
Rel. Air Humidity (non-condensing)			85										%

Features:
No Min. Load Required
Internal Soft-Start (8 ms)
Short-Circuit Robust
No Output Capacitor Required
Pin-out compatible with 78XX Linear-regulator's

1 Amp, WIDE INPUT RANGE, STEP-DOWN CONVERTER

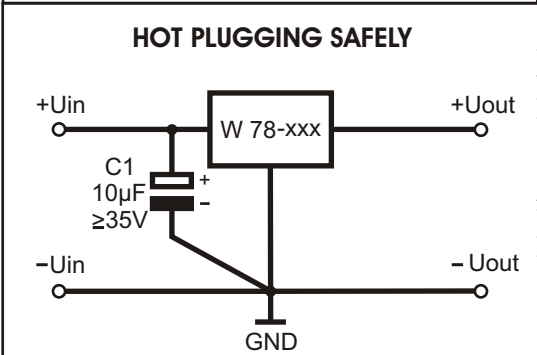
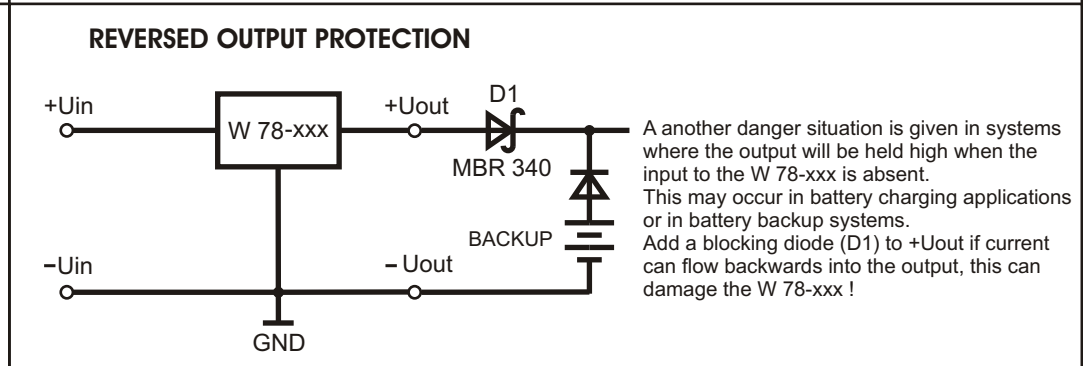
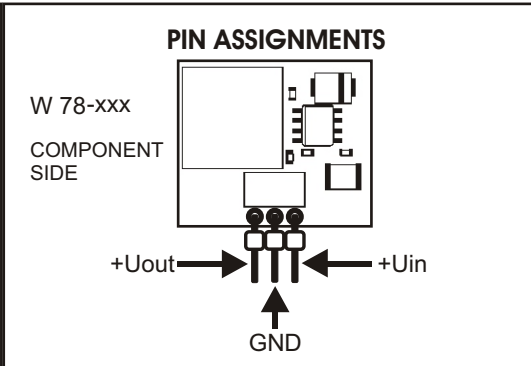
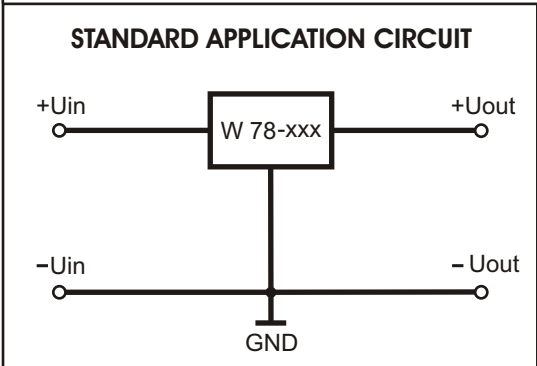
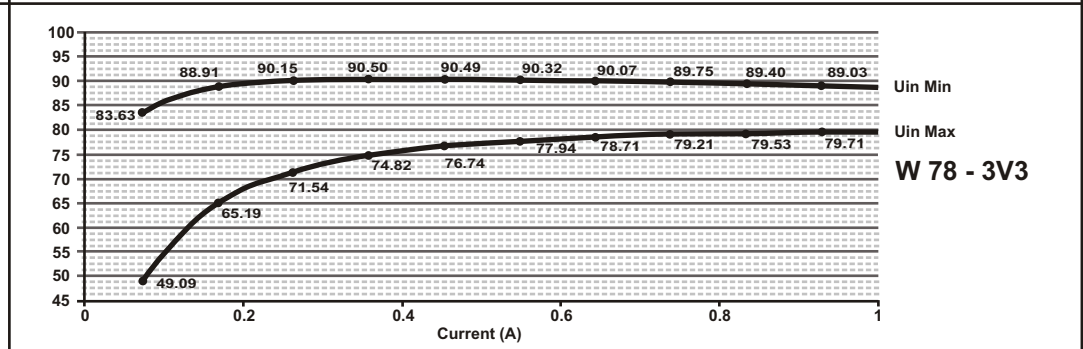
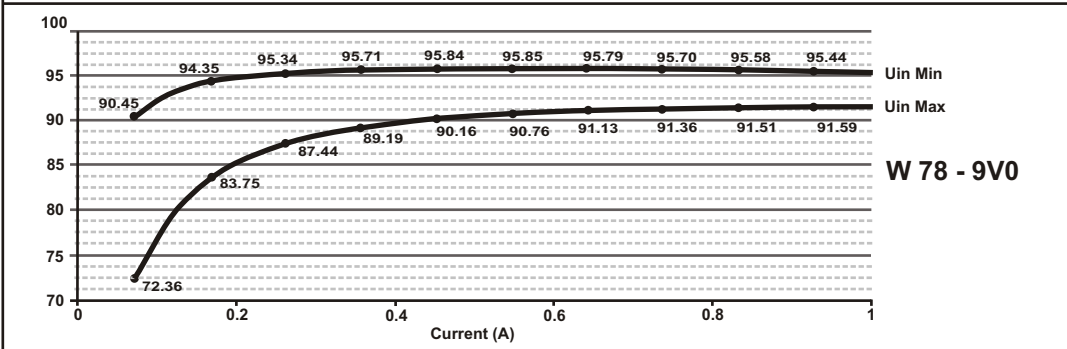
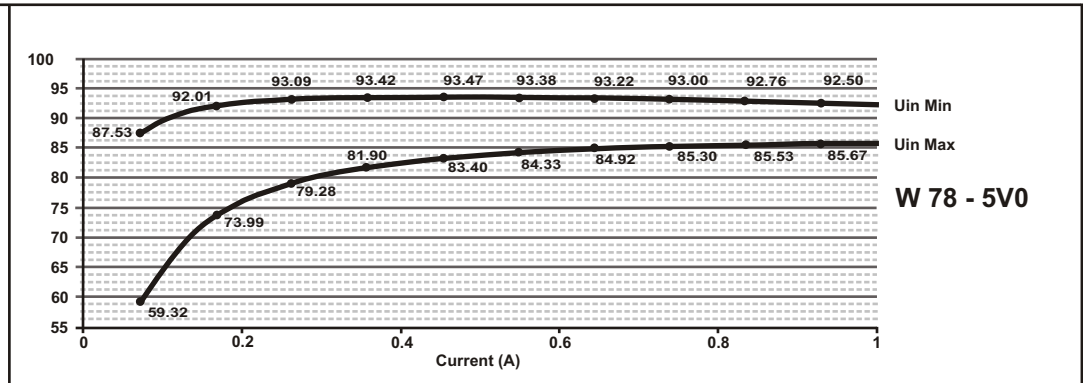
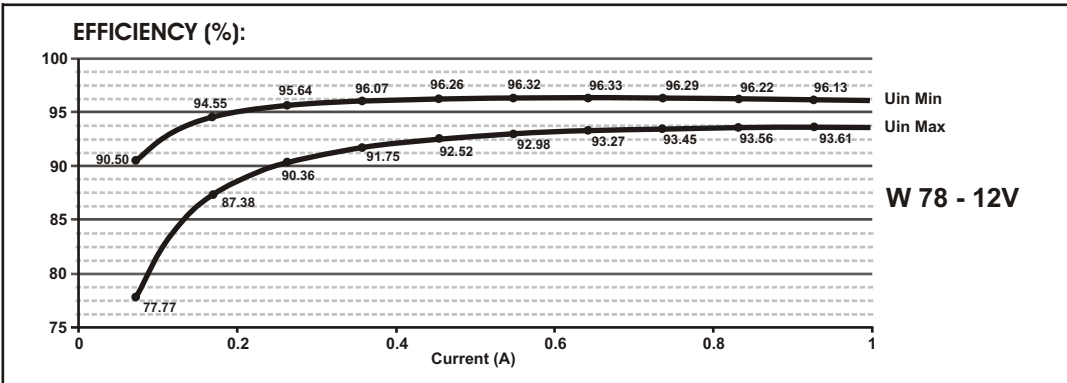

The low loss input capacitor of the W78-xxx combined with stray inductance (wire or pcb track) in series with the power source forms an underdamped tank circuit. The voltage at the Uin pin can ring to twice the nominal input voltage, possibly exceeding the W78-xxx max.(34V) rating and damaging the part.

An aluminium electrolytic capacitor (C1) has been added. This capacitor's high equivalent series resistance damps the tank circuit and eliminates the voltage overshoot. The extra capacitor improves low frequency ripple filtering and can slightly improve the efficiency.

CONRAD ELECTRONIC

RoHS konform

Type:	Item No:
W78 - 3V3	16 78 03
W78 - 5V0	16 78 05
W78 - 9V0	16 78 09
W78 - 12V	16 78 12

Note:
This DC/DC converter is a "non-CE-checked" component. The utilisation must comply with the CE norms.

These operating instructions are published by:
Conrad Electronic SE, Klaus-Conrad-Straße 1, D-92240 Hirschau/Germany
The operating instructions reflect the current technical specifications at time of print.
We reserve the right to change the technical or physical specifications.
© Copyright 2009 by Conrad Electronic SE.

*01/09-NB