

1. Scope

The KSM-60□LM2M consist of a PIN Photodiode of high speed and a preamplifier IC in the package as an receiver for Infrared remote control systems

2. Features

- 2.7 ~ 5.5 Volt supply voltage, low power consumption
- Shielded against electrical field disturbance
- High immunity against ambient light
- Easy interface with the main board
- TTL and CMOS compatibility
- One mold package
- RoHS Compliance



3. Applications

TV, VTR, Audio, Air Conditioners, Car Stereo Units, Computers, Interior controlling appliances, and appliances that require remote controlling

4. Package Outline

See the attached Drawing No. (RM-60□LM□□-ASY-01)

5. Absolute Maximum Ratings (at 25 °C Unless otherwise notes)

Parameter	Symbol	Ratings	Unit
Supply Voltage	Vcc	6	V
Operating Temperature	Topr	- 20 to +80	°C
Storage Temperature	Tstg	- 25 to +85	°C
Manual soldering Temperature	Tsol	260(Max 5 sec)	°C

6. Reliability Test

Parameter	Condition
High Temperature *1	Ta= +80°C , Vcc=5V Time=24H
High Temperature/High Humidity *1	Ta= +85°C , RH=85% , Vcc=5V Time=24H
Low Temperature *1	Ta= +30°C , Vcc=5V Time=24H
Heat Cycle *1	-25°C at 30 mins to +85°C at 30 mins for 20 cycles
Dropping *2	Test devices shall be dropped 3 time naturally onto hard wooden board from a 75 cm height position

Note : *1. electro-optical characteristics shall be satisfied after leaving 2hours in the normal temperature

*2. electro-optical characteristics shall be satisfied and no deforms and destructions of appearance.

(excepting deforms of terminals)

7. Electrical Characteristics

[Ta= 25°C, Vcc= 5.0V]

Parameter	Symbol	Condition	Min.	Typ.	Max.	Unit
Supply Voltage Range	Vcc		2.7	-	5.5	V
Current Consumption	Icc	No Input Signal	Vcc=5V	-	1.0	mA
			Vcc=3V	-	0.8	
Peak Wavelength *3	λ_p		-	940	-	nm
B.P.F Center Frequency *4	fo		-	*4	-	kHz
Arrival Distance *3	L	250Lux	0°	17	-	m
			±30°	14	-	m
H Level Output Voltage *3	V _{OH}	30cm over the ray axis	Vcc-0.5	Vcc-0.3	-	V
L Level Output Voltage *3	V _{OL}		-	0.2	0.5	V
H Level Output Pulse Width *3	T _{WH}	Burst Wave = 600µs Period = 1.2ms	400	-	800	µs
L Level Output Pulse Width *3	T _{WL}		400	-	800	µs
Output Form	Active Low Output					

Note : *3. It specifies the maximum distance between emitter and detector that the output waveform satisfies the standard(8-2,3) under the conditions below against the standard transmitter

- 1) Measuring place : Indoor without extreme reflection of light
- 2) Ambient light source : Detecting surface illumination shall be irradiate 200±50Lux under ordinary white fluorescence lamp without high frequency lightning
- 3) Standard transmitter : Burst wave indicated in drawing(8-1) of standard transmitter shall be arranged to 200mVp-p under the measuring circuit specified in drawing(8-2,3)

4) Application Circuit

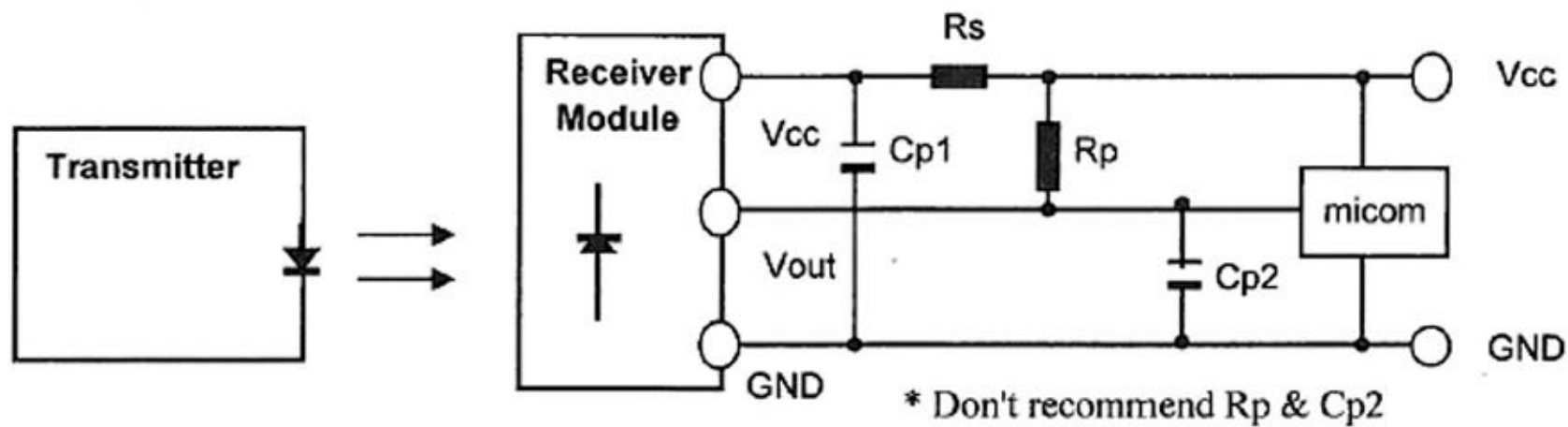

- 1) Rs (Vcc input series resistor) : 100 ohm ~ 470ohm
- 2) Cp1(Vcc-GND terminal series Condenser) : 47uF ~ 100uF
- 3) Rp (Vcc-Vout terminal Pullup resistor) : Optional (when using 10K ohm or more)
- 4) Cp2(Vcc-GNDterminal parallel Condenser) : Optional (when using 100pF less than)

*4. B.P.F Center Frequency(fo) of each model is shown below

Model NO.	B.P.F Center Frequency(kHz)
KSM-601 Series	40.0
KSM-602 Series	36.7
KSM-603 Series	37.9
KSM-604 Series	32.7
Not Support	56.9

8. Measure Method

8-1. Output Pulse Width

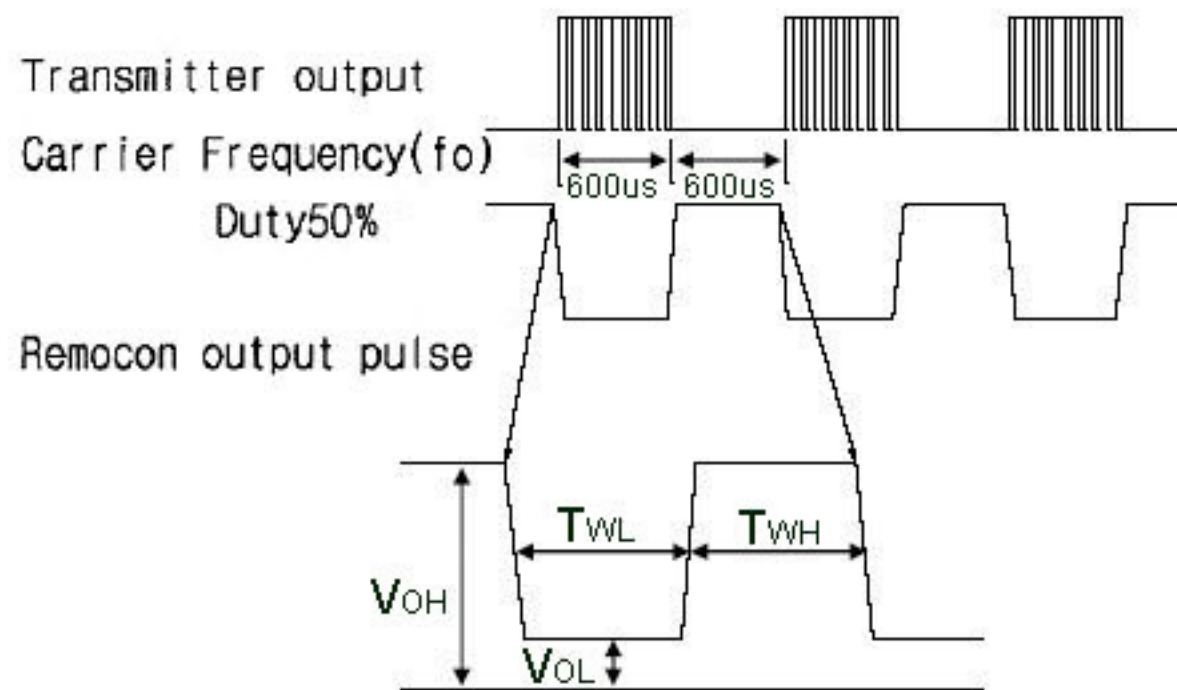

8-2. Standard Transmitter

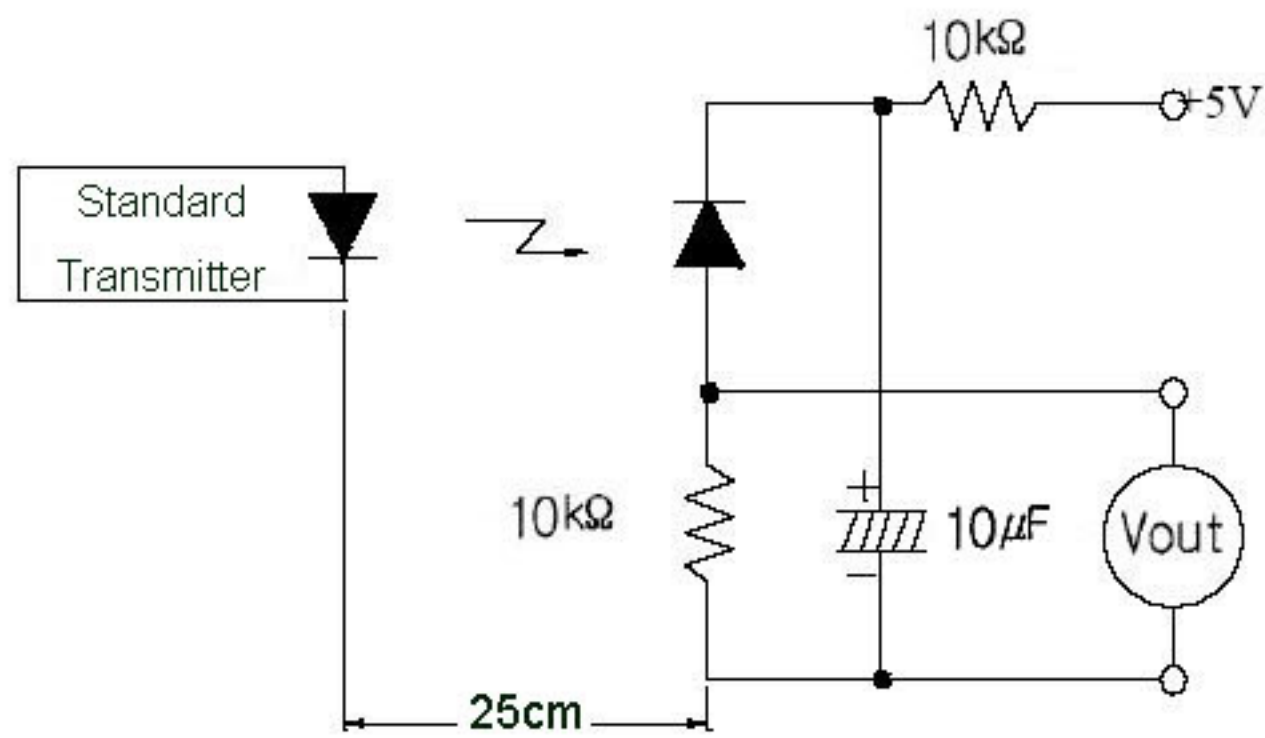

8-3. Test Condition of Arrival Distance

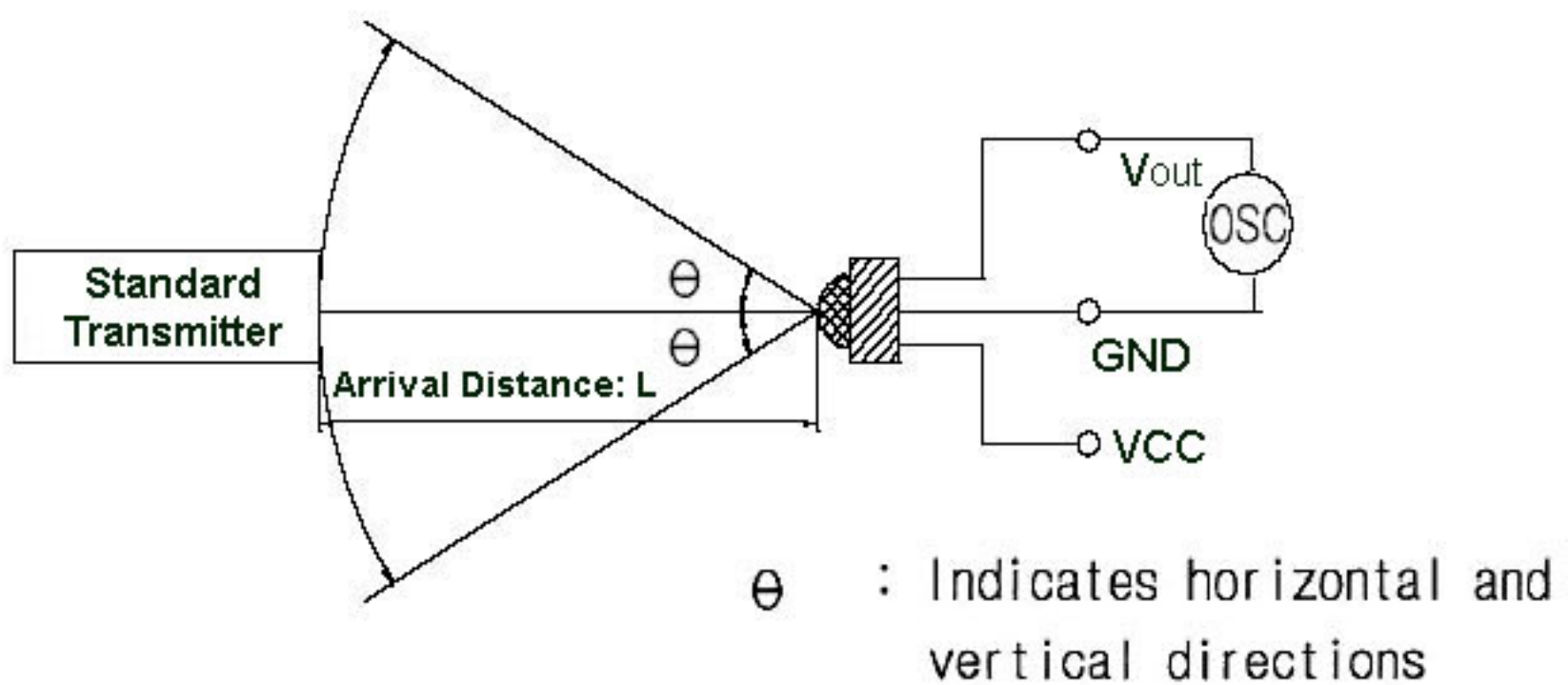

9. Standard Inspection

Among electrical characteristics, total quantity shall be inspected as below

- 9-1. Front distance between emitter and detector
- 9-2. Current consumption
- 9-3. H level output voltage
- 9-4. L level output voltage

10. Customer must check below clause before using

10-1. When this infrared remote control detecting unit shall be adopted for wireless remote control, please keep the following standards.

- 1) Data word length = Max. 100msec
- 2) t_{pause} = Min. 25msec
- 3) Duty(Σt_{burst} / T) = Max. 30%
- 4) t_{Burst} = Min. 300usec
- 5) t_{Gap} = Min. 300usec
- 6) above (1)~(5) should be all meet and all remote control button should be operated properly.

suitable DATA FORMAT : ● : continuouse key ×: one key					
NEC CODE	●	SONY 12bit	●	Matsushita Code	●
RC5 /RC6	●	SONY 15bit	×	Mitsubishi Code	×
Toshiba Micom Code	●	SONY 20bit	×	Zenith Code	●
Sharp Code	●	RCMM	×	JVC Code	●
Continuous Data communication don't support. (t _{pause} = 0ms)					

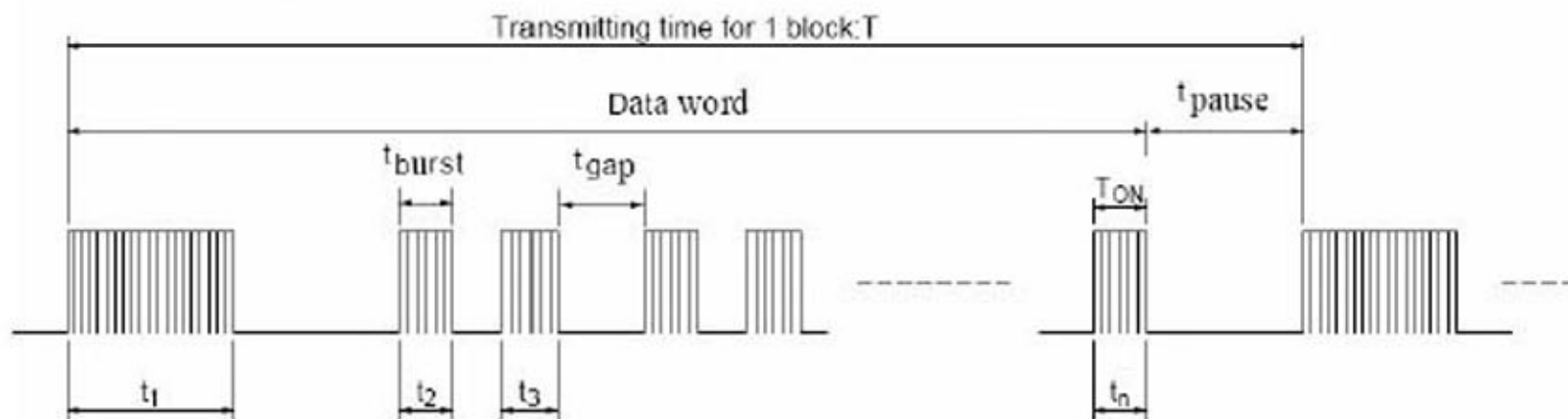

- 10-2. If your condition doesn't meet the above statement, it has a chanec to operate unsuitably.
- 10-3. It should be minimum 30 cm off between RC-M and Transmitter for normal operating.
if the RC-M and Transmitter are near too much, it has a chance to no response.

11. Caution(When use and storage of this device)

- 11-1. Store and use where there is no force causing transformation or change in quality
- 11-2. Store and use when there is no extreme humidity
- 11-3. Do not wash this device. Wipe the stains of diode side with a soft cloth.
You can use the solvent, ethylalcohol or methylalcohol or isopropylalcohol only.
- 11-4. The shield case shall be grounded on the PCB pattern. There are two cases, one is that shield case and GND pin are connected in the shiled case, the other is not connected in it.
If the receiver modules of shield case is not becoming ground connection, there is a possibility of being weak in the EMI(Electronic Microwave Interperence) condition.
- 11-5. Solder pad within the condition of ratings. after soldering do not add extrorse force.
- 11-6. Put decoupling device between V_{cc} and GND for reduce the noise from power supply line.
recommmand V_{cc}-GND 47μF and V_{cc}- 100Ω. Decoupling device should be near receiver modules.

11-7. The decrease in distance, the output noise, the malfunction, etc. might occur because of a surrounding electromagnetic environment.

11-8. To prevent static electricity damage to the Pre-AMP make sure that the human body, the soldering iron is connected to ground before using

11-9. This device has to control of static electricity

KODENSHI Korea Corp. guarantees a KSM-60□LM2M up to M.M 200V , HBM 2KV

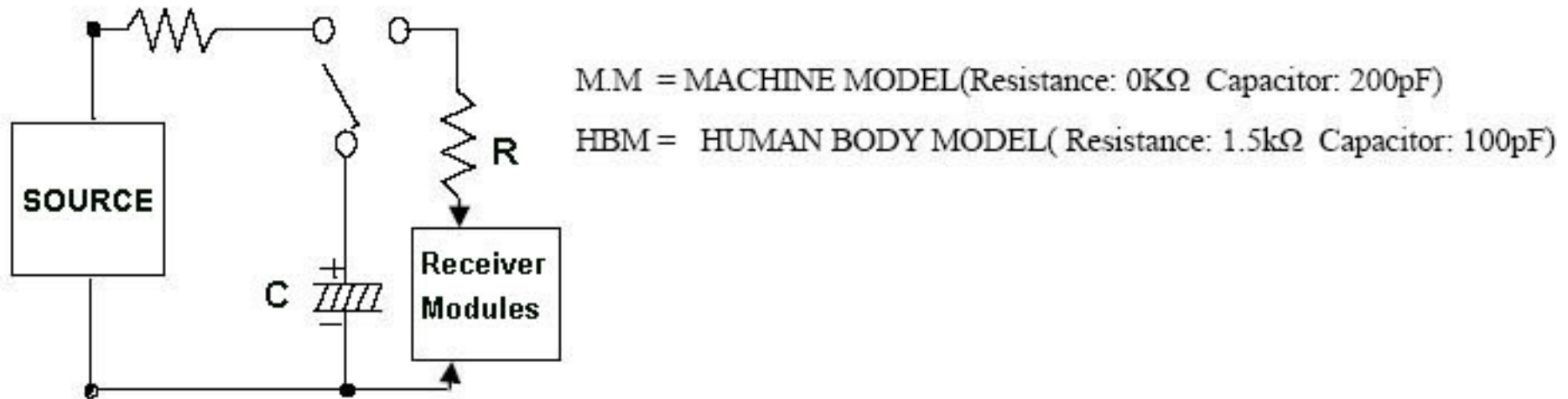

11-10. This device is not design to endure radiate rays and heavily charged particles.

12. Period of Guarantee and Extent of Guarantee

12-1.Period of Guarantee

1 year after designated place.

12-2.Extent of Guarantee

KODENSHI Korea Corp. Shall supply the replacements against defects that will caused from KODENSHI fault.

12-3 .This product complies with RoHS directive.

Object : mercury, lead, cadmium, hexavalent chromium, polybrominated biphenyls and polybrominated diphenyl others

13. Recommand wave solder condition for Lead-free

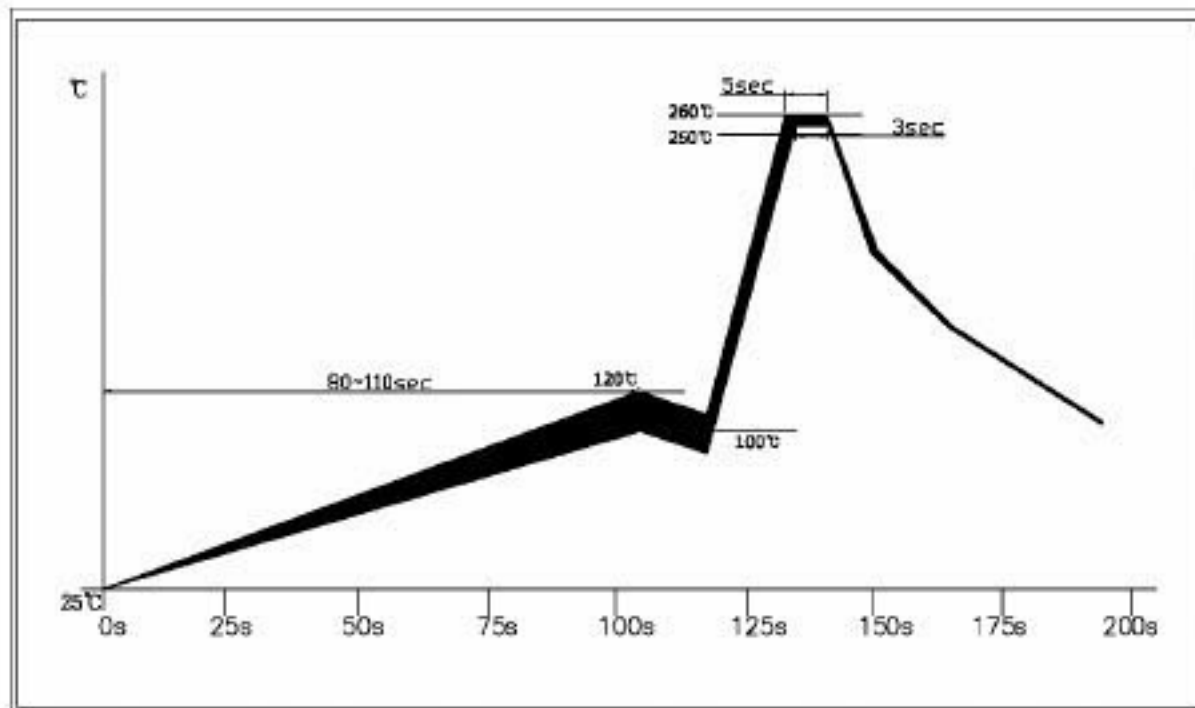

13-1. Pre-heating temperature is 100~120 °C, for a duration about 80~110seconds, the speed of raise temperature is 1~2 °C/sec

13-2. The peak temperature is 255±5 °C, the duration for 3~5seconds.

13-3. The speed of refrigerate is 10 °C/sec

13-4. The total time of Wave solder is about 3.5 minutes.

14. Typical -Electro-Optical Characteristics

- Vertical Direction Characteristics

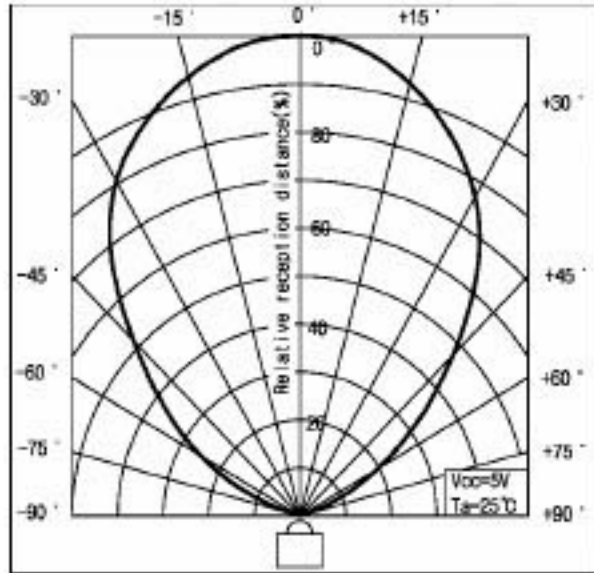

- Horizontal Direction Characteristics

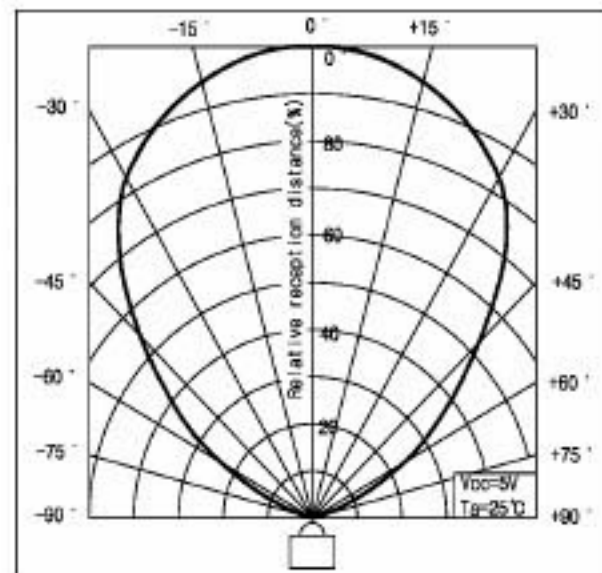

15. Others

In case where any trouble or questions arise, both parties agree to make full discussion covering the said problem

* Packing Specification

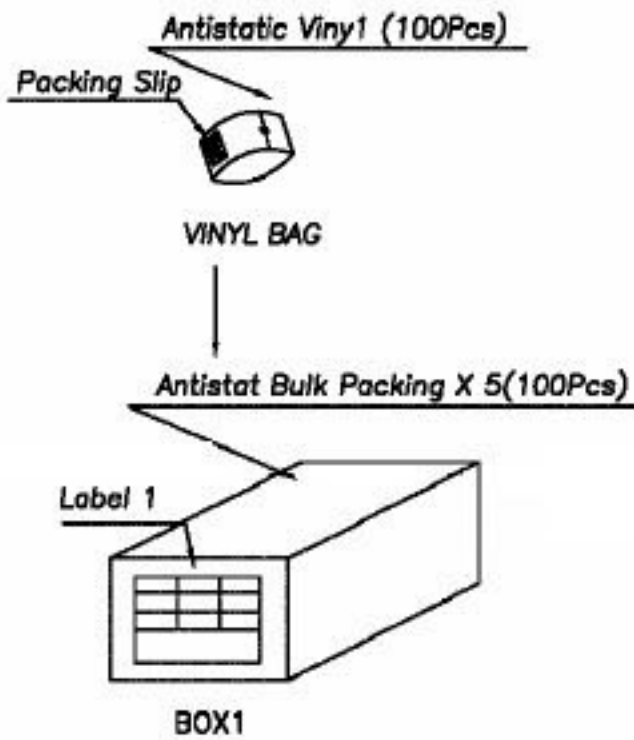

* Lot NO. = K 4 3 4 - 001-01
 KODENSHI
 Product Year
 Product Week
 BOX Number

MARK	REVISION	DATE	NAME	SIGN

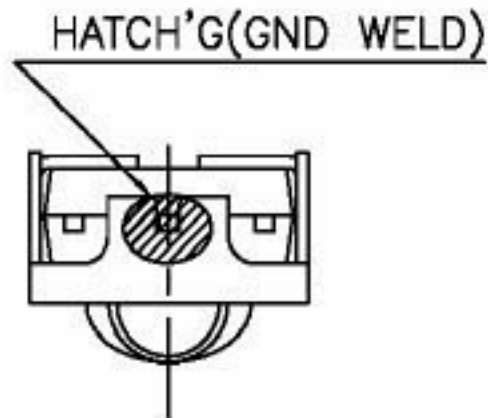

- NOTE**
- PIN CONFIG
 ① Vout
 ② GND
 ③ Vcc
 - G.T : ±0.3
 - LEAD Pb Free

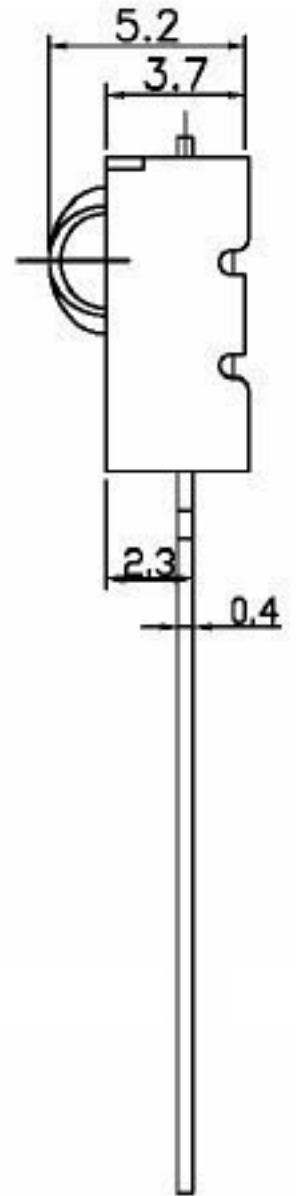
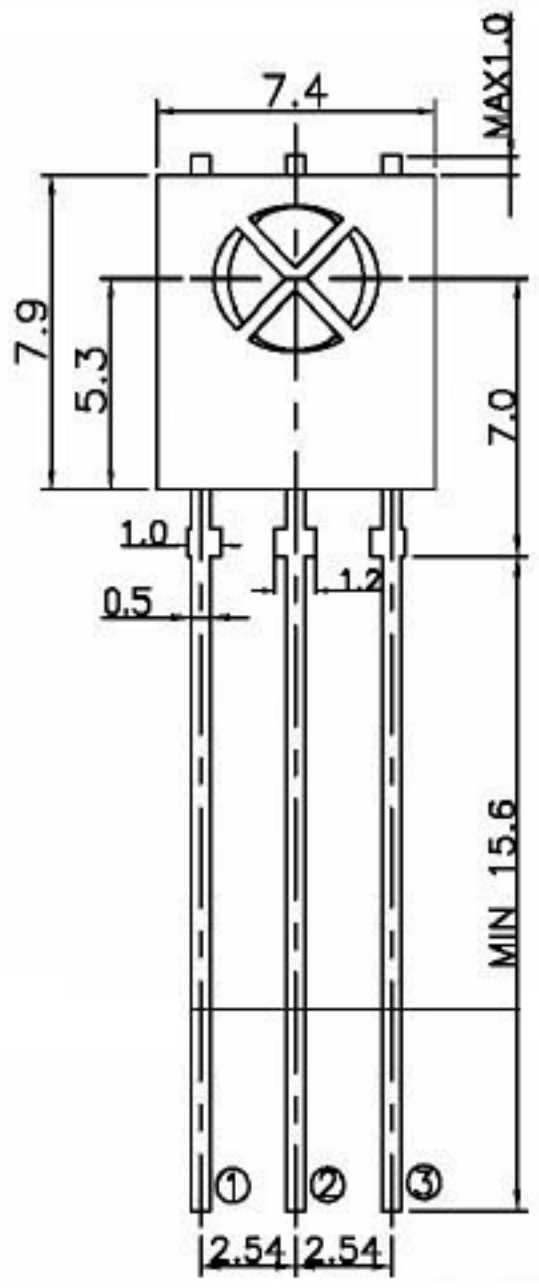

★RoHS Compliance

NO	DESCRIPTION			MAT'L	DIMENSION	REMARK
ISSUE	REVIEW	REVIEW	APPR'L	Q'TY	TITLE	KSM-60□LM□□ Series
L.S.H			L.K.Y	UNIT	MM	
				SCALE	4/1	
DRAWING NO		REF DWG NO				
RM-60□LM□□-ASY-01						