

HSMx-A10x-xxxxx PLCC-2

Surface Mount LED Indicator



Data Sheet



Lead (Pb) Free
RoHS 6 fully
compliant

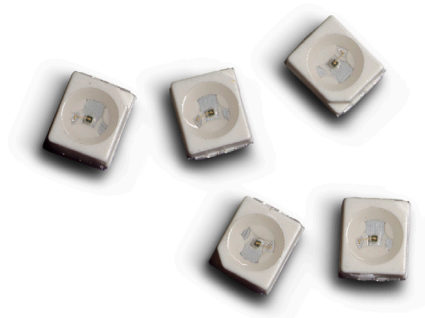

Description

This family of SMT LEDs is packaged in the industry standard PLCC-2 package. These SMT LEDs have high reliability performance and are designed to work under a wide range of environmental conditions. This high reliability feature makes them ideally suited to be used under harsh interior automotive as well as interior signs application conditions.

To facilitate easy pick & place assembly, the LEDs are packed in EIA-compliant tape and reel. Every reel will be shipped in single intensity and color bin, except red color, to provide close uniformity.

These LEDs are compatible with IR solder reflow process. Due to the high reliability feature of these products, they can also be mounted using through-the-wave soldering process.

The super wide viewing angle at 120° makes these LEDs ideally suited for panel, push button, or general backlighting in automotive interior, office equipment, industrial equipment, and home appliances. The flat top emitting surface makes it easy for these LEDs to mate with light pipes. With the built-in reflector pushing up the intensity of the light output, these LEDs are also suitable to be used as LED pixels in interior electronic signs.

Features

- Industry standard PLCC-2 package
- High reliability LED package
- High brightness using AlInGaP and InGaN dice technologies
- Available in full selection of colors
- Super wide viewing angle at 120°
- Available in 8 mm carrier tape on 7 inch reel (2000 pieces)
- Compatible with both IR and TTW soldering process

Applications

- Interior automotive
 - Instrument panel backlighting
 - Central console backlighting
 - Cabin backlighting
- Electronic signs and signals
 - Interior full color sign
 - Variable message sign
- Office automation, home appliances, industrial equipment
 - Front panel backlighting
 - Push button backlighting
 - Display backlighting

CAUTION: HSMN,M,K and E-A10x-xxxxx LEDs are Class 2 ESD sensitive. Please observe appropriate precautions during handling and processing. Refer to Avago Application Note AN-1142 for additional details.

Package Dimensions

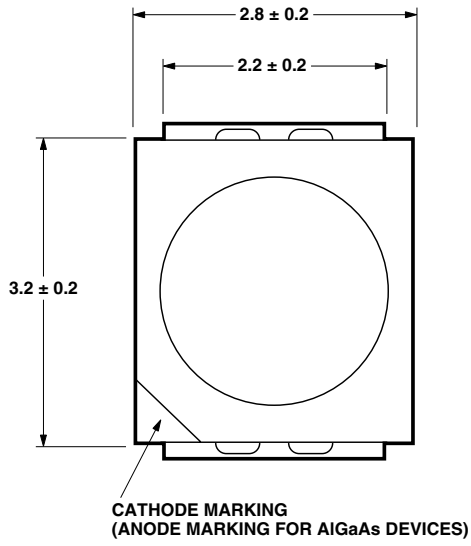

TOP MOUNT

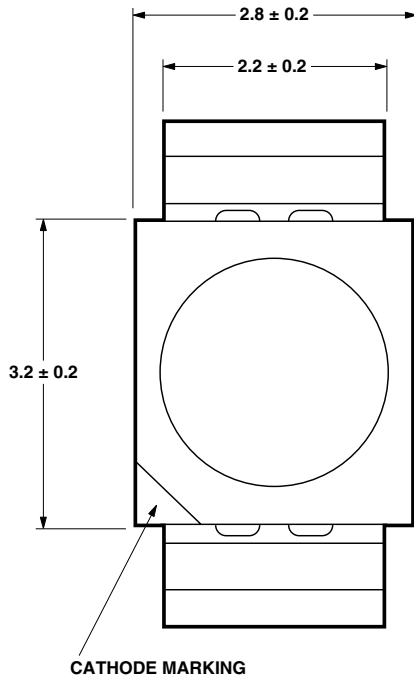
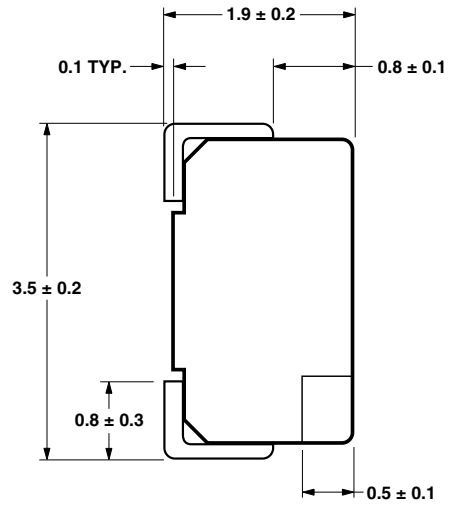

REVERSE MOUNT

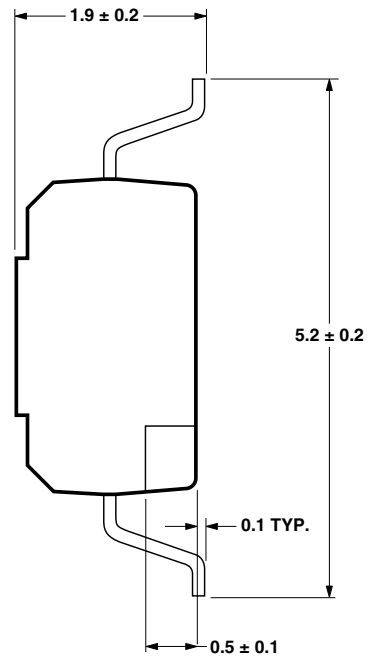

NOTE: ALL DIMENSIONS IN MILLIMETERS.

Table 1. Device Selection Guide

Red					
Part Number	Min IV (mcd)	Typ. IV (mcd)	Max. IV (mcd)	Test Current (mA)	Dice Technology
HSMS-A100-J00J1	4.50	15.00	-	20	GaP
HSMS-A100-L00J1	11.20	15.00	-	20	GaP
HSMS-A100-H70J2	3.55	-	7.20	10	GaP
HSMS-A100-J80J2	5.60	-	14.00	10	GaP
HSMH-A100-L00J1	11.20	15.00	-	20	AlGaAs
HSMH-A100-N00J1	28.50	50.00	-	20	AlGaAs
HSMH-A100-L70J2	14.00	-	28.50	10	AlGaAs
HSMH-A100-M80J2	22.40	-	56.00	10	AlGaAs
HSMH-A100-P30J1	45.00	-	90.00	20	AlGaAs
HSMC-A100-J00J1	4.50	100.00	-	20	AllnGaP
HSMC-A100-Q00J1	71.50	100.00	-	20	AllnGaP
HSMC-A100-R00J1	112.50	140.00	-	20	AllnGaP
HSMC-A101-S00J1	180.00	220.00	-	20	AllnGaP
HSMZ-A100-T00J1	285.00	350.00	-	20	AllnGaP
HSMC-A100-P30J1	45.00	-	90.00	20	AllnGaP
HSMC-A101-R80J1	140.00	-	355.00	20	AllnGaP
HSMZ-A100-S80J1	224.00	-	560.00	20	AllnGaP

Red Orange					
Part Number	Min IV (mcd)	Typ. IV (mcd)	Max. IV (mcd)	Test Current (mA)	Dice Technology
HSMJ-A100-Q00J1	71.50	100.00	-	20	AllnGaP
HSMJ-A101-S00J1	180.00	200.00	-	20	AllnGaP
HSMV-A100-T00J1	285.00	350.00	-	20	AllnGaP
HSMJ-A100-Q30J1	71.50	-	140.00	20	AllnGaP
HSMJ-A100-R40J1	112.50	-	285.00	20	AllnGaP
HSMJ-A101-R80J1	140.00	-	355.00	20	AllnGaP
HSMV-A100-S80J1	224.00	-	560.00	20	AllnGaP

Orange					
Part Number	Min IV (mcd)	Typ. IV (mcd)	Max. IV (mcd)	Test Current (mA)	Dice Technology
HSMD-A100-J00J1	4.50	15.00	-	20	GaP
HSMD-A100-L00J1	11.20	15.00	-	20	GaP
HSMD-A100-J7PJ2	5.60	-	11.20	10	GaP
HSMD-A100-K4PJ2	7.20	-	18.00	10	GaP
HSML-A100-Q00J1	71.50	100.00	-	20	AllnGaP
HSML-A101-S00J1	180.00	220.00	-	20	AllnGaP
HSML-A100-Q7PJ1	90.00	-	180.00	20	AllnGaP
HSML-A100-R7PJ1	140.00	-	285.00	20	AllnGaP
HSML-A101-R8WJ1	140.00	-	355.00	20	AllnGaP

Yellow / Amber

Part Number	Min IV (mcd)	Typ. IV (mcd)	Max. IV (mcd)	Test Current (mA)	Dice Technology
HSMY-A100-J00J1	4.50	12.00	-	20	GaP
HSMY-A100-L00J1	11.20	12.00	-	20	GaP
HSMY-A100-J35J2	4.50	-	9.00	10	GaP
HSMY-A100-K45J2	7.20	-	18.00	10	GaP
HSMA-A100-Q00J1	71.50	100.00	-	20	AllnGaP
HSMA-A101-S00J1	180.00	220.00	-	20	AllnGaP
HSMU-A100-S00J1	180.00	320.00	-	20	AllnGaP
HSMA-A100- Q35J1	71.50	-	140.00	20	AllnGaP
HSMA-A100- R45J1	112.50	-	285.00	20	AllnGaP
HSMA-A101-R8WJ1	140.00	-	355.00	20	AllnGaP
HSMU-A100-S4WJ1	180.00	-	450.00	20	AllnGaP

Yellow Green

Part Number	Min IV (mcd)	Typ. IV (mcd)	Max. IV (mcd)	Test Current (mA)	Dice Technology
HSMG-A100-J02J1	4.50	18.00	-	20	GaP
HSMG-A100-K72J2	9.00	-	18.00	10	GaP
HSME-A100-M02J1	18.00	70.00	-	20	AllnGaP
HSME-A100-N82J1	35.50	-	90.00	20	AllnGaP

Emerald Green

Part Number	Min IV (mcd)	Typ. IV (mcd)	Max. IV (mcd)	Test Current (mA)	Dice Technology
HSMG-A100-H01J1	2.80	8.00	-	20	GaP
HSMG-A100-G31J2	1.80	-	3.55	10	GaP
HSMG-A100-H41J2	2.80	-	7.20	10	GaP
HSME-A100-L01J1	11.20	40.00	-	20	AllnGaP
HSME-A100-M3PJ1	18.00	-	35.50	20	AllnGaP

Green

Part Number	Min IV (mcd)	Typ. IV (mcd)	Max. IV (mcd)	Test Current (mA)	Dice Technology
HSMM-A101-R00J1	112.50	200.00	-	20	InGaN
HSMM-A100-S00J1	180.00	350.00	-	20	InGaN
HSMM-A101-Q7PJ1	90.00	-	140.00	20	InGaN
HSMM-A101-R7PJ1	140.00	-	285.00	20	InGaN
HSMM-A101-R8PJ1	140.00	-	355.00	20	InGaN
HSMM-A100-S8PJ1	224.00	-	560.00	20	InGaN

Cyan

Part Number	Min IV (mcd)	Typ. IV (mcd)	Max. IV (mcd)	Test Current (mA)	Dice Technology
HSMK-A101-R00J1	112.50	170.00	-	20	InGaN
HSMK-A100-S00J1	180.00	280.00	-	20	InGaN
HSMK-A100-S8WJ1	224.00	-	560.00	20	InGaN
HSMK-A101-Q3WJ1	71.50	-	140.00	20	InGaN
HSMK-A101-R4WJ1	112.50	-	285.00	20	InGaN

Blue

Part Number	Min IV (mcd)	Typ. IV (mcd)	Max. IV (mcd)	Test Current (mA)	Dice Technology
HSMB-A100-J00J1	4.50	15.00	-	20	GaN
HSMB-A100-J70J1	5.60	-	11.20	10	GaN
HSMB-A100-K80J2	9.00	-	22.40	10	GaN
HSMN-A101-N00J1	28.50	50.00	-	20	InGaN
HSMN-A100-P00J1	45.00	70.00	-	20	InGaN
HSMN-A101-N7YJ1	35.50	-	71.50	20	InGaN
HSMN-A100-P8YJ1	56.00	-	140.00	20	InGaN

Notes:

1. The luminous intensity IV, is measured at the mechanical axis of the lamp package. The actual peak of the spatial radiation pattern may not be aligned with this axis.
2. IV Tolerance = $\pm 12\%$

Part Numbering System

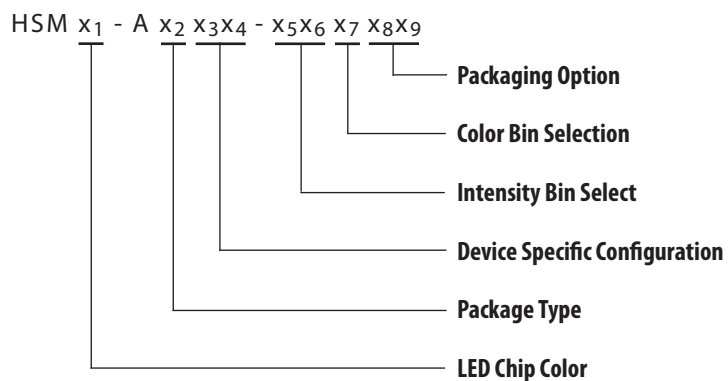

Absolute Maximum Ratings (T_A = 25°C)

Parameters	HSMS/D/Y/G	HSMH	HSMC/J/L/A	HSME	HSMZ/V/U	HSMM/K/B/N
DC Forward Current ^[1]	30 mA	30 mA	30 mA ^[3,4]	20 mA ^[4]	30 mA ^[3,4]	30 mA
Peak Forward Current ^[2]	100 mA	100 mA	100 mA	100 mA	100 mA	100 mA
Power Dissipation	63 mW	60 mW	63 mW	48 mW	72 mW	114 mW
Reverse Voltage	5 V					
Junction Temperature	110°C					
Operating Temperature	-55°C to +100°C					
Storage Temperature	-55°C to +100°C					

Notes:

1. Derate linearly as shown in Figure 4.
2. Duty factor = 10%, Frequency = 1 kHz.
3. Drive current between 10 mA and 30 mA is recommended for best long term performance.
4. Operation at current below 5 mA is not recommended.

Optical Characteristics (T_A = 25°C)

Color	Part Number	Dice Technology	Peak Wavelength	Dominant Wavelength ^[1]	Viewing Angle	Luminous Efficacy η_v ^[3]	Luminous Intensity/ Total Flux
			λ_{PEAK} (nm) Typ.	λ_D (nm) Typ.	$2 \theta_{1/2}$ ^[2] (Degrees) Typ.	(lm/W) Typ.	$I_v(\text{mcd})/\Phi_v(\text{mlm})$ Typ.
Red	HSMS-A100	GaP	635	626	120	120	0.45
	HSMH-A100	AlGaAs	645	637	120	63	0.45
	HSMC-A10x	AllnGaP	635	626	120	150	0.45
	HSMZ-A100	AllnGaP	639	630	120	155	0.45
Red Orange	HSMJ-A10x	AllnGaP	621	615	120	240	0.45
	HSMV-A100	AllnGaP	623	617	120	263	0.45
Orange	HSMD-A100	GaP	600	602	120	380	0.45
	HSM L-A10x	AllnGaP	609	605	120	320	0.45
Amber	HSMY-A100	GaP	583	585	120	520	0.45
	HSM A-A10x	AllnGaP	592	590	120	480	0.45
	HSMU-A100	AllnGaP	594	592	120	500	0.45
Yellow Green	HSMG-A100	GaP	565	569	120	590	0.45
	HSME-A100	AllnGaP	575	570	120	560	0.45
Emerald Green	HSMG-A100	GaP	558	560	120	650	0.45
	HSME-A100	AllnGaP	566	560	120	610	0.45
Green	HSM M-A10x	InGaN	523	525	120	500	0.45
Cyan	HSMK-A10x	InGaN	502	505	120	300	0.45
Blue	HSM B-A100	GaN	428	462	120	65	0.45
	HSM N-A10x	InGaN	468	470	120	75	0.45

Notes:

1. The dominant wavelength, λ_D , is derived from the CIE Chromaticity Diagram and represents the color of the device.
2. $\theta_{1/2}$ is the off-axis angle where the luminous intensity is 1/2 the peak intensity.
3. Radiant intensity, I_e in watts/steradian, may be calculated from the equation $I_e = I_v/\eta_v$, where I_v is the luminous intensity in candelas and η_v is the luminous efficacy in lumens/watt.

Electrical Characteristics (T_A = 25°C)

Part Number	Forward Voltage V _F (Volts) @ I _F = 20 mA		Reverse Voltage V _R @ 100 μ A	Reverse Voltage V _R @ 10 μ A	Thermal Resistance R θ_{JP} (°C/W)
	Typ.	Max.	Min.	Min.	
HSMS/D/Y/G	2.2	2.6	5	—	180
HSMH	1.9	2.6	5	—	180
HSMC/J/L/A/E	1.9	2.4	5	—	280
HSMZ/V/U	2.2	2.6	5	—	280
HSM B	3.9	4.3	—	5	280
HSM M/K/N	3.4	4.05	—	5	280

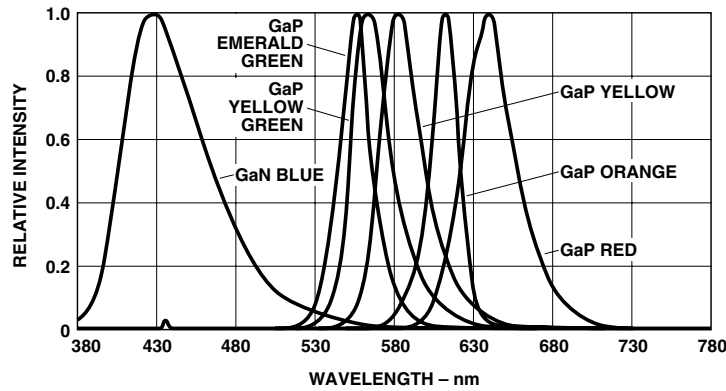
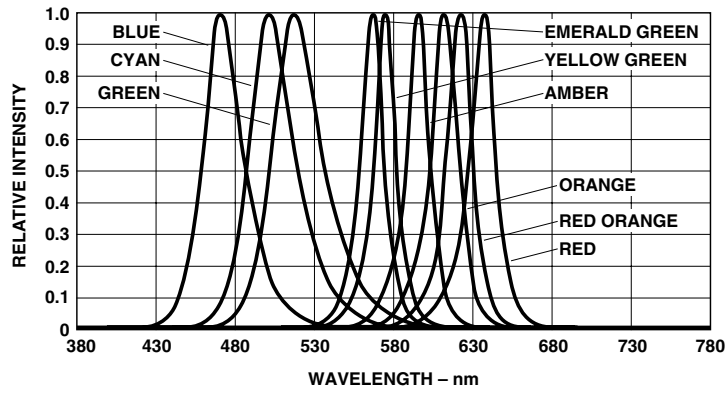

Figure 1. Relative intensity vs. wavelength.

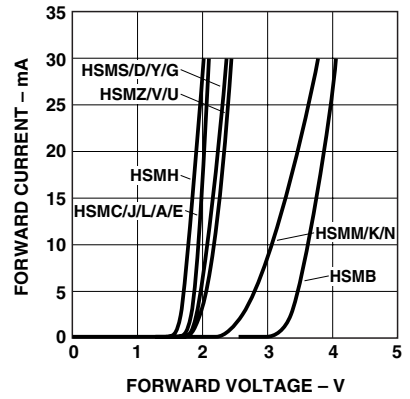

Figure 2. Forward current vs. forward voltage.

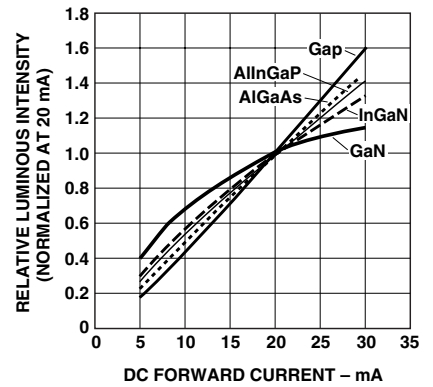

Figure 3. Relative intensity vs. forward current.

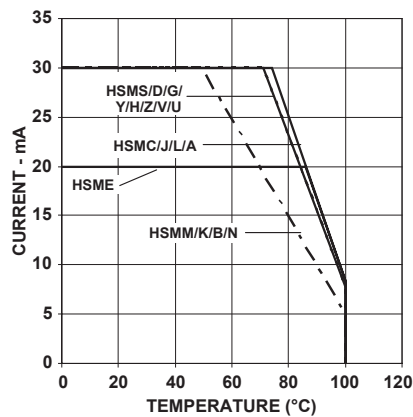

Figure 4. Maximum forward current vs. ambient temperature. Derated based on $T_{jMAX} = 110^{\circ}C$, $R\theta_{JA} = 500^{\circ}C/W$.

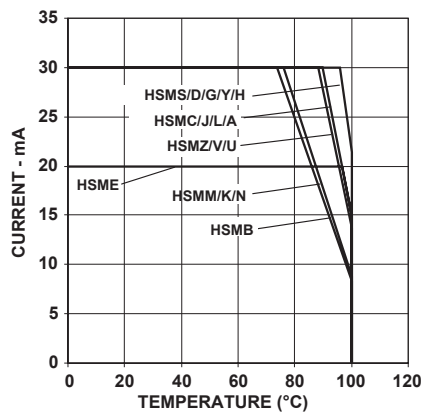

Figure 4b. Maximum Forward Current Vs. Solder Point Temperature. Derated based on $T_{jMAX} = 110^{\circ}C$, $R\theta_{JP} = 180^{\circ}C/W$ or $280^{\circ}C/W$.

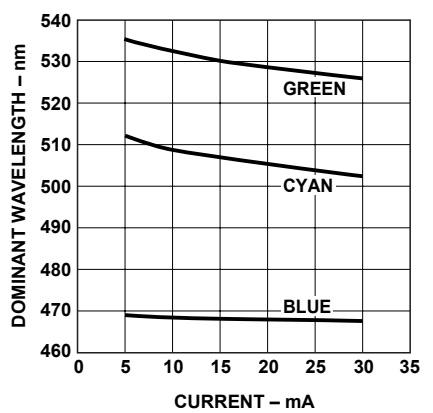

Figure 5. Dominant wavelength vs. forward current – InGaN devices.

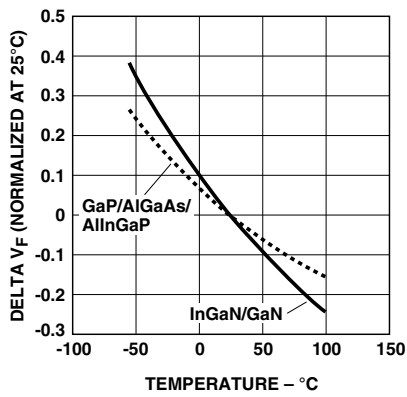

Figure 6. Forward voltage shift vs. temperature.

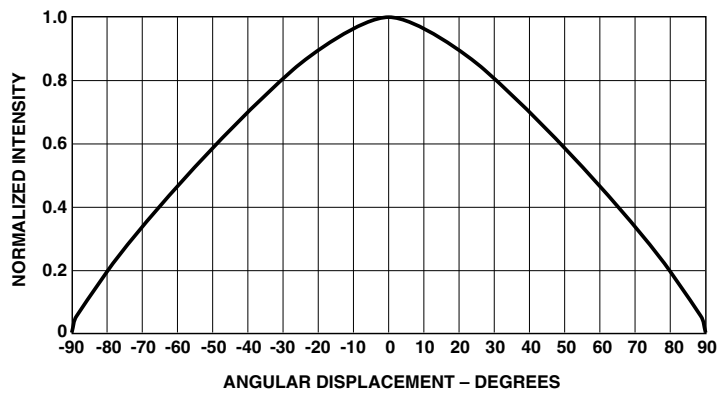

Figure 7. Radiation Pattern.

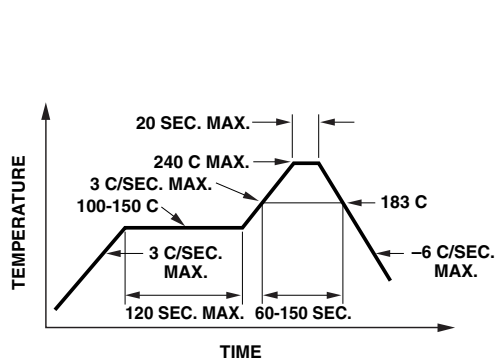

Figure 8a. Recommended SnPb reflow soldering profile.

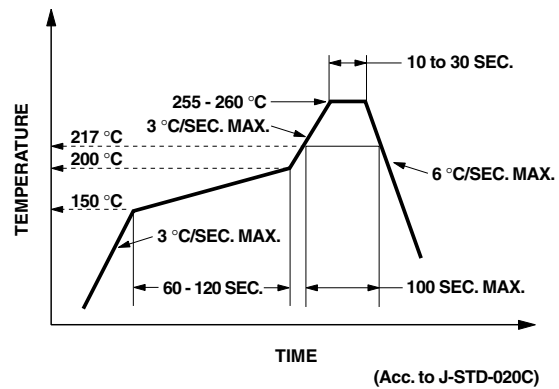
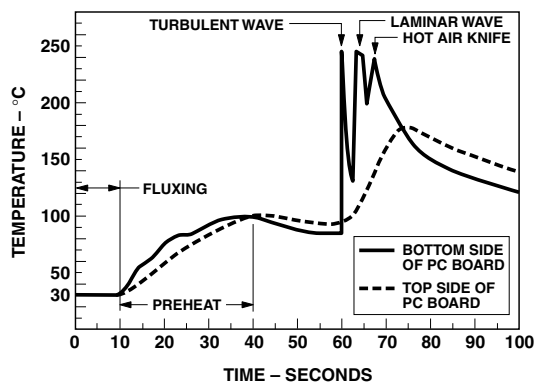

Figure 8b. Recommended Pb-free reflow soldering profile.

Note: For detail information on reflow soldering of Avago surface mount LEDs, do refer to Avago Application Note AN 1060 Surface Mounting SMT LED Indicator Components.



CONVEYOR SPEED = 1.83 M/MIN (6 FT/MIN)
 PREHEAT SETTING = 150°C (100°C PCB)
 SOLDER WAVE TEMPERATURE = 245°C
 AIR KNIFE AIR TEMPERATURE = 390°C
 AIR KNIFE DISTANCE = 1.91 mm (0.25 IN.)
 AIR KNIFE ANGLE = 40°
 LEADED SOLDER: SN63; FLUX: RMA
 LEAD-FREE SOLDER: 96.5 wt% SN, 3 wt% Ag, 0.5 wt% Cu

NOTE: ALLOW FOR BOARDS TO BE SUFFICIENTLY COOLED BEFORE EXERTING MECHANICAL FORCE.

Figure 9. Recommended wave soldering profile.

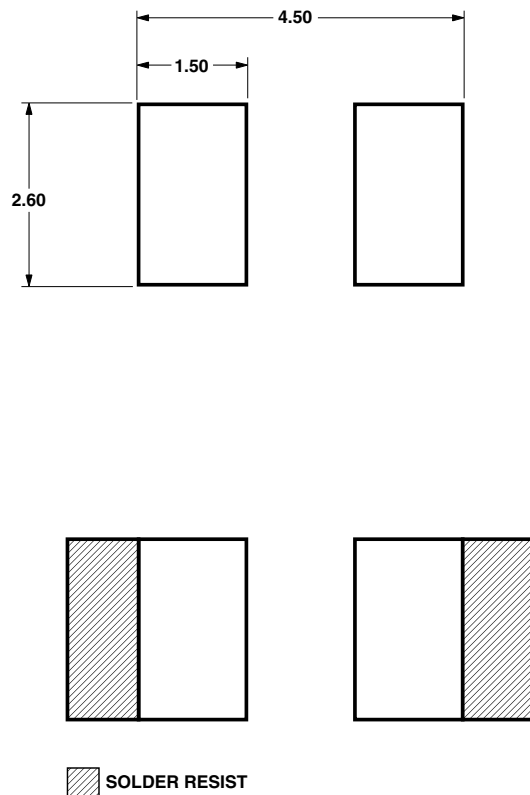

Figure 10. Recommended soldering pad pattern.

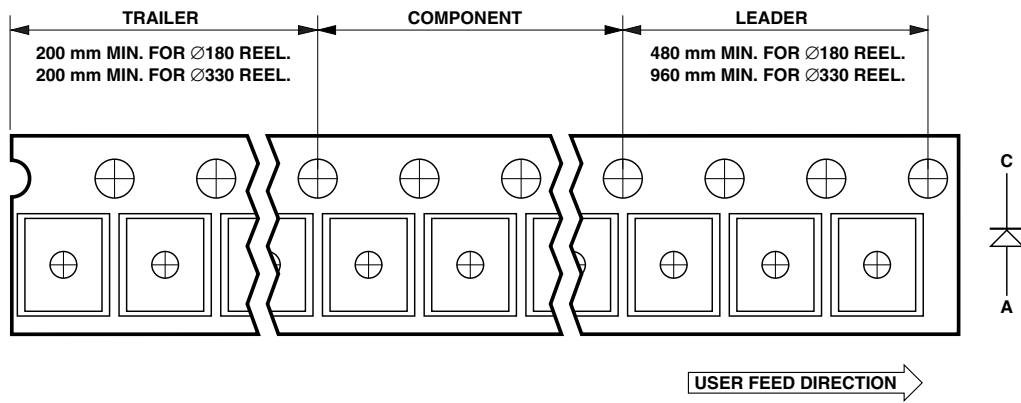

Figure 11. Tape leader and trailer dimensions.

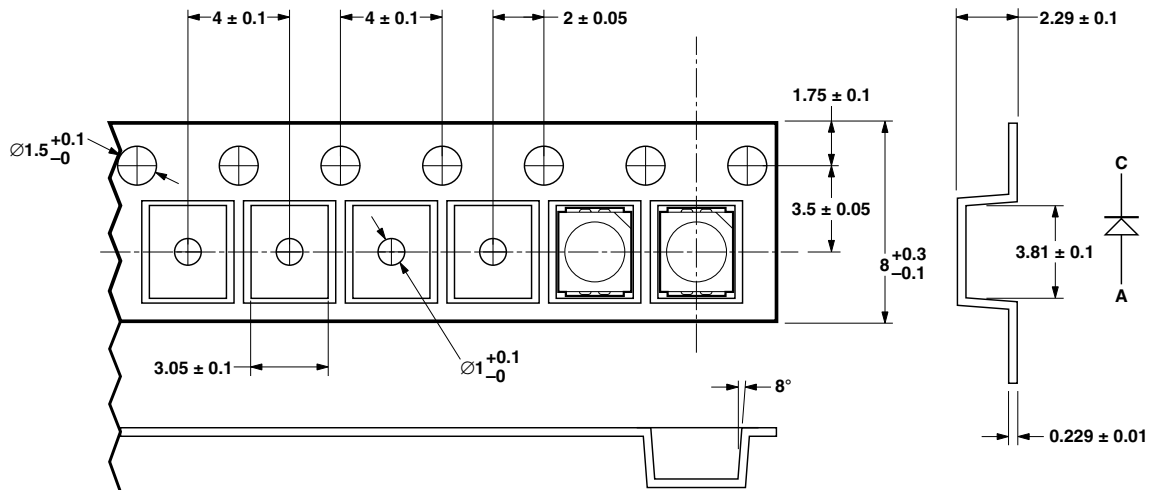

Figure 12. Tape dimensions.

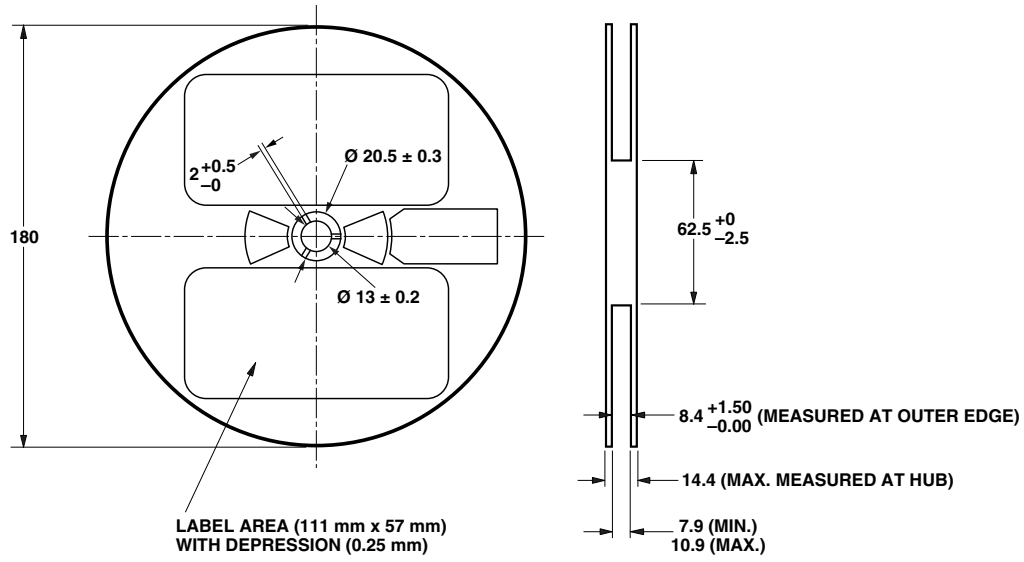

Figure 13. Reel dimensions.

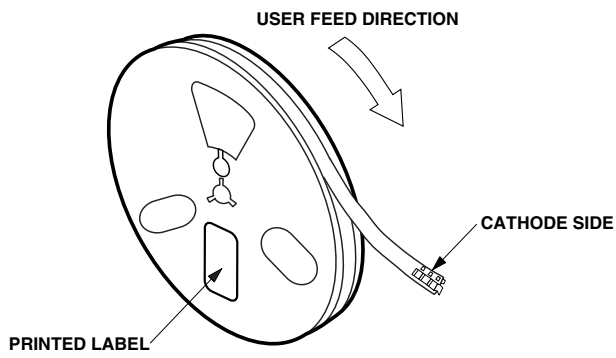

Figure 14. Reeling orientation.

Intensity Bin Select (X₅X₆)

Individual reel will contain parts from one half bin only.

X ₅	Min I _v Bin
X ₆	
0	Full Distribution
2	2 half bins starting from X ₅ 1
3	3 half bins starting from X ₅ 1
4	4 half bins starting from X ₅ 1
5	5 half bins starting from X ₅ 1
6	2 half bins starting from X ₅ 2
7	3 half bins starting from X ₅ 2
8	4 half bins starting from X ₅ 2
9	5 half bins starting from X ₅ 2

Intensity Bin Limits

Bin ID	Min. (mcd)	Max. (mcd)
G1	1.80	2.24
G2	2.24	2.80
H1	2.80	3.55
H2	3.55	4.50
J1	4.50	5.60
J2	5.60	7.20
K1	7.20	9.00
K2	9.00	11.20
L1	11.20	14.00
L2	14.00	18.00
M1	18.00	22.40
M2	22.40	28.50
N1	28.50	35.50
N2	35.50	45.00
P1	45.00	56.00
P2	56.00	71.50
Q1	71.50	90.00
Q2	90.00	112.50
R1	112.50	140.00
R2	140.00	180.00
S1	180.00	224.00
S2	224.00	285.00
T1	285.00	355.00
T2	355.00	450.00
U1	450.00	560.00
U2	560.00	715.00
V1	715.00	900.00
V2	900.00	1125.00

Tolerance of each bin limit = ± 12%

Color Bin Select (X₇)

Individual reel will contain parts from one full bin only.

X ₇	
0	Full Distribution
Z	A and B only
Y	B and C only
W	C and D only
V	D and E only
U	E and F only
T	F and G only
S	G and H only
Q	A, B, and C only
P	B, C, and D only
N	C, D, and E only
M	D, E, and F only
L	E, F, and G only
K	F, G, and H only
1	A, B, C, and D only
2	E, F, G, and H only
3	B, C, D, and E only
4	C, D, E, and F only
5	A, B, C, D, and E only
6	B, C, D, E, and F only

Color Bin Limits

Blue	Min. (nm)	Max. (nm)
A	460.0	465.0
B	465.0	470.0
C	470.0	475.0
D	475.0	480.0

Cyan	Min. (nm)	Max. (nm)
A	490.0	495.0
B	495.0	500.0
C	500.0	505.0
D	505.0	510.0

Green	Min. (nm)	Max. (nm)
A	515.0	520.0
B	520.0	525.0
C	525.0	530.0
D	530.0	535.0

Color Bin Limits

Emerald Green	Min. (nm)	Max. (nm)
A	552.5	555.5
B	555.5	558.5
C	558.5	561.5
D	561.5	564.5

Yellow Green	Min. (nm)	Max. (nm)
E	564.5	567.5
F	567.5	570.5
G	570.5	573.5
H	573.5	576.5

Amber	Min. (nm)	Max. (nm)
A	582.0	584.5
B	584.5	587.0
C	587.0	589.5
D	589.5	592.0
E	592.0	594.5
F	594.5	597.0

Orange	Min. (nm)	Max. (nm)
A	597.0	600.0
B	600.0	603.0
C	603.0	606.0
D	606.0	609.0
E	609.0	612.0

Red Orange	Min. (nm)	Max. (nm)
A	611.0	616.0
B	616.0	620.0

Red	Min. (nm)	Max. (nm)
Full Distribution		

Tolerance of each bin limit = ± 1 nm.

Packaging Option (X₈X₉)

Option	Test Current	Package Type	Reel Size
J1	20 mA	Top Mount	7 inch
J4	20 mA	Top Mount	13 inch
H1	20 mA	Reverse Mount	7 inch
H4	20 mA	Reverse Mount	13 inch
J2	10 mA	Top Mount	7 inch
J5	10 mA	Top Mount	13 inch
H2	10 mA	Reverse Mount	7 inch
H5	10 mA	Reverse Mount	13 inch

Moisture Sensitivity

This product is qualified as Moisture Sensitive Level 2a per Jedec J-STD-020. Precautions when handling this moisture sensitive product is important to ensure the reliability of the product. Do refer to Avago Application Note AN5305 Handling of Moisture Sensitive Surface Mount Devices for details.

A. Storage before use

- Unopen moisture barrier bag (MBB) can be stored at <40°C/90%RH for 12 months. If the actual shelf life has exceeded 12 months and the HIC indicates that baking is not required, then it is safe to reflow the LEDs per the original MSL rating.
- It is not recommended to open the MBB prior to assembly (e.g. for IQC).

B. Control after opening the MBB

- The humidity indicator card (HIC) shall be read immediately upon opening of MBB.
- The LEDs must be kept at <30°C / 60%RH at all time and all high temperature related process including soldering, curing or rework need to be completed within 672 hours.

C. Control for unfinished reel

- For any unused LEDs, they need to be stored in sealed MBB with desiccant or desiccator at <5%RH.

D. Control of assembled boards

- If the PCB soldered with the LEDs is to be subjected to other high temperature processes, the PCB need to be stored in sealed MBB with desiccant or desiccator at <5%RH to ensure no LEDs have exceeded their floor life of 672 hours.

E. Baking is required if:

- "10%" is Not blue and "5%" HIC indicator turns pink.
- The LEDs are exposed to condition of >30°C / 60% RH at any time.
- The LEDs floor life exceeded 672 hours.

Recommended baking condition: 60±5°C for 20 hours.

For product information and a complete list of distributors, please go to our website: www.avagotech.com

Avago, Avago Technologies, and the A logo are trademarks of Avago Technologies Limited in the United States and other countries. Data subject to change. Copyright © 2005-2008 Avago Technologies Limited. All rights reserved. Obsoletes AV01-0040EN AV02-0198EN - June 3, 2008

AVAGO
TECHNOLOGIES