

AN1304

Integrated Sensor Simplifies Bar Graph Pressure Gauge

Prepared by: Warren Schultz
Discrete Applications Engineering

INTRODUCTION

Integrated semiconductor pressure sensors such as the MPX5100 greatly simplify electronic measurement of pressure. These devices translate pressure into a 0.5 to 4.5 volt output range that is designed to be directly compatible with microcomputer A/D inputs. The 0.5 to 4.5 volt range also

facilitates interface with ICs such as the LM3914, making Bar Graph Pressure Gauges relatively simple. A description of a Bar Graph Pressure Sensor Evaluation Board and its design considerations are presented here.

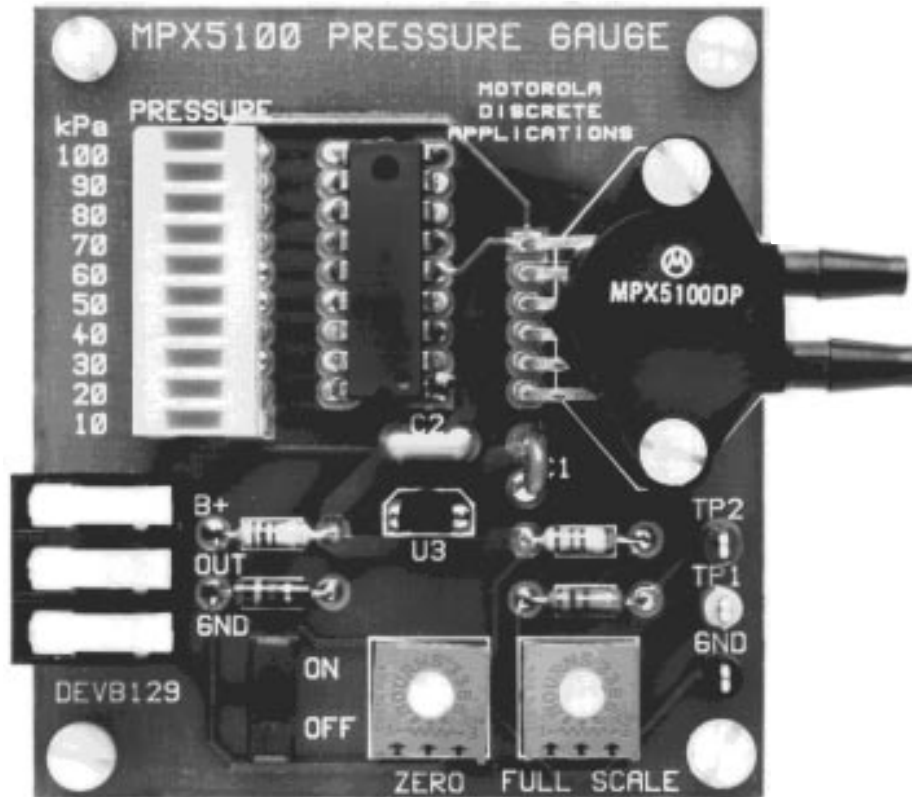

Figure 1. DEVB129 MPX5100 Bar Graph Pressure Gauge

EVALUATION BOARD DESCRIPTION

A summary of the information required to use evaluation board number DEVB129 is presented as follows. A discussion of the design appears under the heading Design Considerations.

FUNCTION

The evaluation board shown in Figure 1 is designed to provide a 100 kPa full scale pressure measurement. It has two input ports. P1, the pressure port is on the top side of the MPX5100 sensor, and P2, a vacuum port, is on the bottom side. These ports can be supplied up to 100 kPa (15 psi)* of pressure on P1 or up to 100 kPa of vacuum on P2, or a differential pressure up to 100 kPa between P1 and P2. Any of these sources will produce the same output.

The primary output is a 10 segment LED bar graph, which is labeled in increments of 10 kPa. If full scale pressure is adjusted for a value other than 100 kPa the bar graph may be read as a percent of full scale. An analog output is also provided. It nominally supplies 0.5 volts at zero pressure and 4.5 volts at 100 kPa. Zero and full scale adjustments are made with potentiometers so labeled at the bottom of the board. Both adjustments are independent of each other.

ELECTRICAL CHARACTERISTICS

The following electrical characteristics are included to describe evaluation board operation. They are not specifications in the usual sense and are intended only as a guide to operation.

Characteristic	Symbol	Min	Typ	Max	Units
Power Supply Voltage	B+	6.8	—	13.2	Volts
Full Scale Pressure	PFS	—	—	100	kPa
Overpressure	PMAX	—	—	700	kPa
Analog Full Scale	VFS	—	4.5	—	Volts
Analog Zero Pressure Offset	V _{OFF}	—	0.5	—	Volts
Analog Sensitivity	SAOUT	—	40	—	mV/kPa
Quiescent Current	I _{CC}	—	20	—	mA
Full Scale Current	I _{FS}	—	140	—	mA

CONTENT

Board contents are described in the following parts list, schematic, and silk screen plot. A pin by pin circuit description follows in the next section.

* 100 kPa = 14.7 psi, 15 psi is used throughout the text for convenience

PIN-BY-PIN DESCRIPTION

B+:

Input power is supplied at the B+ terminal. Minimum input voltage is 6.8 volts and maximum is 13.2 volts. The upper limit is based upon power dissipation in the LM3914 assuming all 10 LED's are lit and ambient temperature is 25°C. The board will survive input transients up to 25 volts provided that power dissipation in the LM3914 does not exceed 1.3 watts.

OUT:

An analog output is supplied at the OUT terminal. The signal it provides is nominally 0.5 volts at zero pressure and 4.5 volts at 100 kPa. This output is capable of sourcing 100 μ A at full scale output.

GND:

There are two ground connections. The ground terminal on the left side of the board is intended for use as the power supply return. On the right side of the board, one of the test point terminals is also connected to ground. It provides a convenient place to connect instrumentation grounds.

TP1:

Test point 1 is connected to the zero pressure reference voltage and can be used for zero pressure calibration. To calibrate for zero pressure, this voltage is adjusted with R6 to match the zero pressure voltage that is measured at the analog output (OUT) terminal.

TP2:

Test point 2 performs a similar function at full scale. It is connected to the LM3914's reference voltage which sets the trip point for the uppermost LED segment. This voltage is adjusted via R5 to set full scale pressure.

P1, P2:

Pressure and Vacuum ports P1 & P2 protrude from the MPX5100 sensor on the right side of the board. Pressure port P1 is on the top and vacuum port P2 is on the bottom. Neither is labeled. Either one or a differential pressure applied to both can be used to obtain full scale readings up to 100 kPa (15 psi). Maximum safe pressure is 700 kPa.

DESIGN CONSIDERATIONS

In this type of an application the design challenge is how to interface a sensor with the bar graph output. MPX5100 Sensors and LM3914 Bar Graph Display drivers fit together so cleanly that having selected these two devices the rest of the design is quite straight forward.

A block diagram that appears in Figure 4 shows the LM3914's internal architecture. Since the lower resistor in the input comparator chain is pinned out at R_{LO}, it is a simple matter to tie this pin to a voltage that is approximately equal to the MPX5100's zero pressure output voltage. In Figure 2, this is accomplished by dividing down the 5 volt regulator's output voltage through R1, R4, and adjustment pot R6. The voltage generated at the wiper of R6 is then fed into R_{LO} which matches the sensor's zero pressure voltage and zeros the bar graph.

The full scale measurement is set by adjusting the upper comparator's reference voltage to match the sensor's output at full pressure. An internal regulator on the LM3914 sets this voltage with the aid of resistors R2, R3, and adjustment pot R5 that are shown in Figure 2.

The MPX5100 requires 5 volt regulated power that is supplied by an MC78L05. The LED's are powered directly from LM3914 outputs, which are set up as current sources. Output current to each LED is approximately 10 times the reference current that flows from pin 7 through R2, R5, and R3 to ground. In this design it is nominally $(4.5\text{ V}/4.9\text{K})10 = 9.2\text{ mA}$.

Over a zero to 85°C temperature range accuracy for both the sensor and driver IC are $\pm 2.5\%$, totaling $\pm 5\%$. Given a 10 segment display total accuracy is approximately $\pm(10\text{ kPa} + 5\%)$.

CONCLUSION

Perhaps the most noteworthy aspect to the bar graph pressure gauge described here is how easy it is to design. The interface between an MPX5100 sensor, LM3914 display driver, and bar graph output is direct and straight forward. The

result is a simple circuit that is capable of measuring pressure, vacuum, or differential pressure; and will also send an analog signal to other control circuitry.

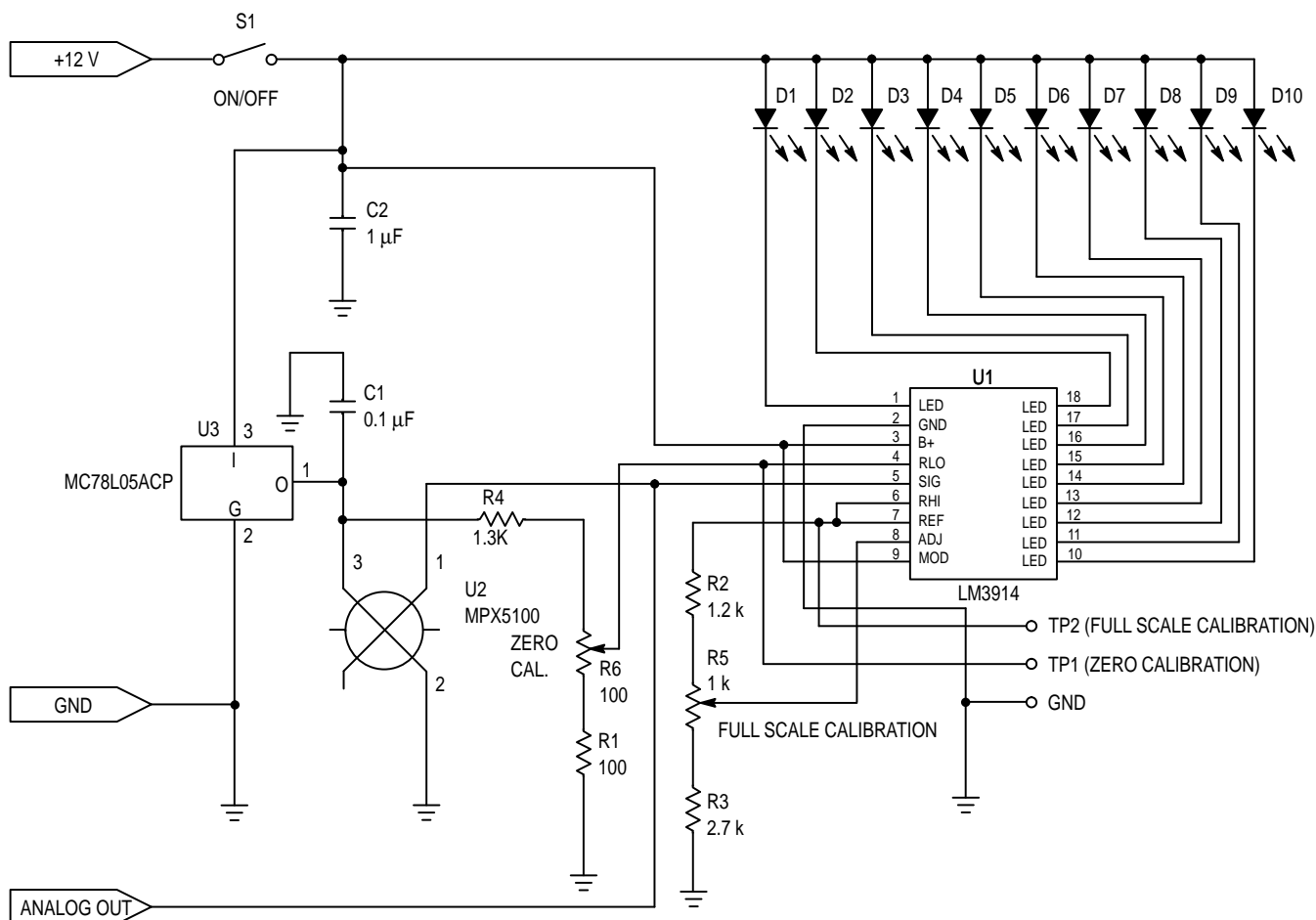

Figure 2. MPX5100 Pressure Gauge

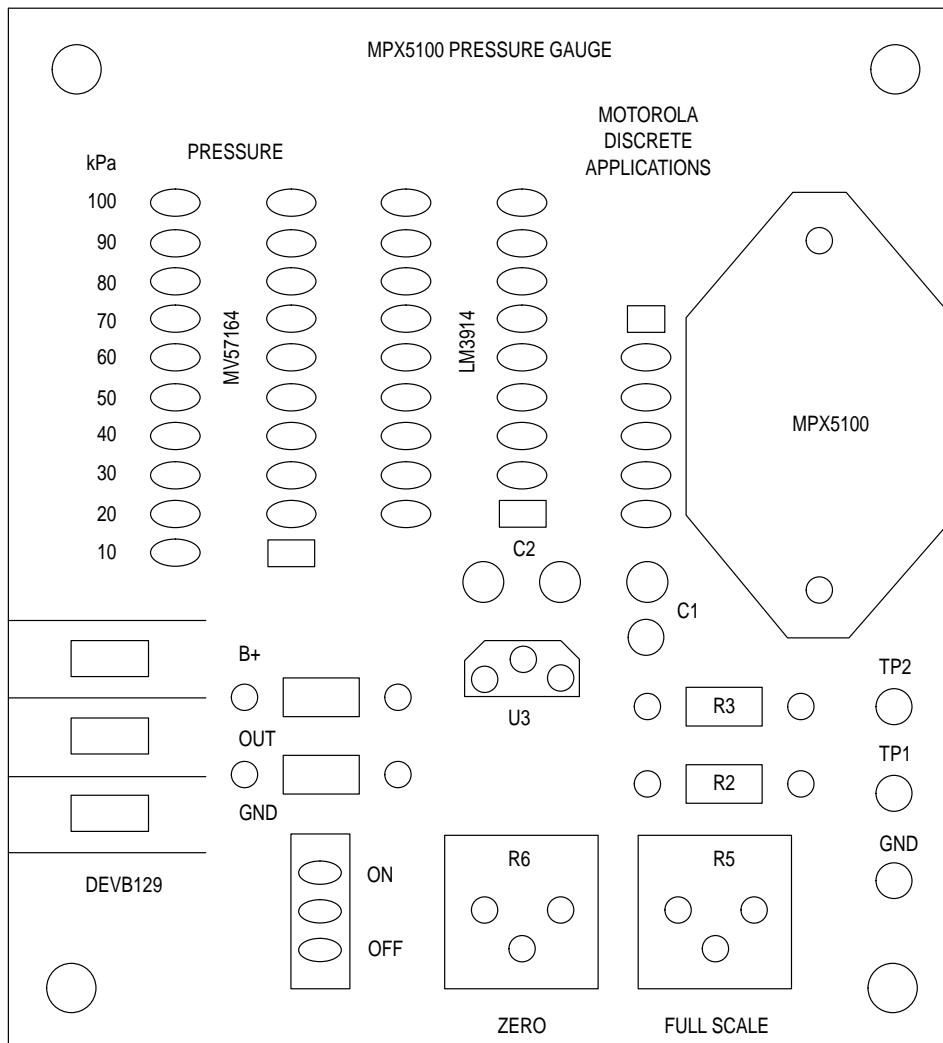

Figure 3. Silk Screen 2X

Table 1. Parts List

Designators	Quant.	Description	Rating	Manufacturer	Part Number
C1	1	Ceramic Cap	0.1 μ F		
C2	1	Ceramic Cap	1 μ F		
D1-D10	1	Bar Graph LED		GI	MV57164
R1	1	1/4 W Film Resistor	100		
R2	1	1/4 W Film Resistor	1.2K		
R3	1	1/4 W Film Resistor	2.7K		
R4	1	1/4 W Film Resistor	1.3K		
R5	1	Trimpot	1K	Bourns	
R6	1	Trimpot	100	Bourns	
S1	1	On/Off Switch		NKK	12SDP2
U1	1	Bar Graph IC		National	LM3914
U2	1	Pressure Sensor		Motorola	MPX5100
U3	1	Voltage Regulator		Motorola	MC78L05ACP
—	1	Terminal Block		Augat	25V03
—	3	Test Point Terminal		Components Corp.	TP1040104
—	4	Nylon Spacer	3/8"		
—	4	4-40 Nylon Screw	1/4"		

Note: All resistors have a tolerance of 5% unless otherwise noted.

All capacitors are 50 volt ceramic capacitors with a tolerance of 10% unless otherwise noted.

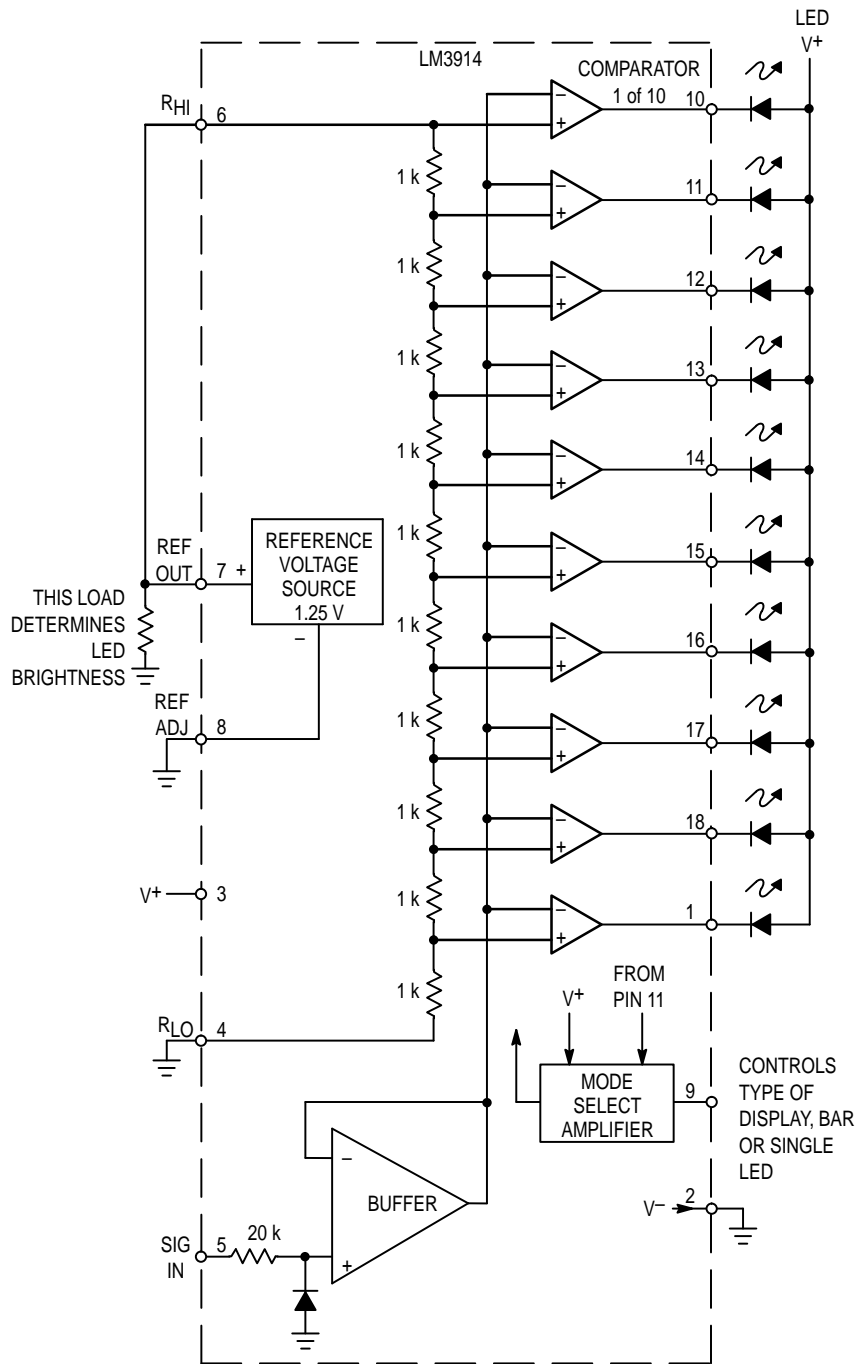

Figure 4. LM3914 Block Diagram

Motorola reserves the right to make changes without further notice to any products herein. Motorola makes no warranty, representation or guarantee regarding the suitability of its products for any particular purpose, nor does Motorola assume any liability arising out of the application or use of any product or circuit, and specifically disclaims any and all liability, including without limitation consequential or incidental damages. "Typical" parameters which may be provided in Motorola data sheets and/or specifications can and do vary in different applications and actual performance may vary over time. All operating parameters, including "Typicals" must be validated for each customer application by customer's technical experts. Motorola does not convey any license under its patent rights nor the rights of others. Motorola products are not designed, intended, or authorized for use as components in systems intended for surgical implant into the body, or other applications intended to support or sustain life, or for any other application in which the failure of the Motorola product could create a situation where personal injury or death may occur. Should Buyer purchase or use Motorola products for any such unintended or unauthorized application, Buyer shall indemnify and hold Motorola and its officers, employees, subsidiaries, affiliates, and distributors harmless against all claims, costs, damages, and expenses, and reasonable attorney fees arising out of, directly or indirectly, any claim of personal injury or death associated with such unintended or unauthorized use, even if such claim alleges that Motorola was negligent regarding the design or manufacture of the part. Motorola and  are registered trademarks of Motorola, Inc. Motorola, Inc. is an Equal Opportunity/Affirmative Action Employer.

Mfax is a trademark of Motorola, Inc.

How to reach us:

USA/EUROPE/Locations Not Listed: Motorola Literature Distribution;
P.O. Box 5405, Denver, Colorado 80217. 303-675-2140 or 1-800-441-2447

JAPAN: Nippon Motorola Ltd.; Tatsumi-SPD-JLDC, 6F Seibu-Butsuryu-Center,
3-14-2 Tatsumi Koto-Ku, Tokyo 135, Japan. 81-3-3521-8315

Mfax™: RMFAX0@email.sps.mot.com – TOUCHTONE 602-244-6609
– US & Canada ONLY 1-800-774-1848

ASIA/PACIFIC: Motorola Semiconductors H.K. Ltd.; 8B Tai Ping Industrial Park,
51 Ting Kok Road, Tai Po, N.T., Hong Kong. 852-26629298

INTERNET: <http://motorola.com/sps>

