

- 1 · Mechanical
- 1 1 · External dimension 120*120*38mm
- 1 2 · Weight 246g/pcs (Lead wire length x 300mm & without connector)
- 1 3 · Bearing Two Ball bearing
- 2 · Electrical characteristic(s) in free air at rated voltage)
 - 2 1 · Rated voltage 12V
 - 2 2 · Rated current 0.5±10%A
 - 2 3 · Rated input power 6.0±10%W
 - 3 · Efficiency
 - 3 1 · Rated speed (range) 2800RPM±10%
 - 3 2 · Maximum air flow 113.9CFM
 - 3 3 · Maximum static air pressure 8.66mm H2O
 - 4 · Characteristics
 - 4 1 · Operating voltage range 7.5V 13.8V
 - 4 2 · Starting voltage 7.5V(ON/OFF)
 - 4 3 · Locked current 0.55A(Reference)
 - 4 4 · Operating temperature 10°C +70°C
 - 4 5 · Storage temperature 30°C +85°C
 - 4 6 · Waterproof class Grade IP58 to an immersion depth of 1.0 metre in water
 - 4 8 · Insulation resistance At least 10MΩ at 500 VDC between housing and both lead wires
 - 4 9 · Dielectric strength Withstand 500 VAC 1 minute 1mA between housing and both lead wires
 - 4 10 · MTBF : 50,000Hours
Life expectancy:50,000Hours continuous operation at rated voltage and normal temperature & humidity
 - 4 11 · Tensile strength of connector Connector will not be any broken at 1 Kg for 15 seconds per piece
 - 4 12 · Acoustic sound level 44.6dBA(Max 44.6dBA)
 - 4 12 1 · Acoustic sound level test descriptions

At rated voltage in sound proof room
Background noise:14.9dBA

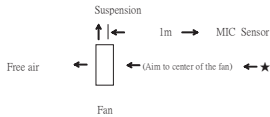

- 4 13 · Characteristics definition:
 - 4 13 1 · Rated current, rated speed, and rated input power shall reach bottom line of specification after 5 minutes continuous rotation at rated voltage and reach standard specification after 10 minutes continuous at rated voltage
 - 4 13 2 · Starting voltage is the least voltage that enables to start the fan by sudden power on

5 · Protection:
Reversal voltage test: We took 200pcs for reversal voltage test at 12V for 1 minutes and all remain still
Fans work normally after corrected voltage

6 · Safety	UL	CE	RoHS
		✓	✓

7 · Material

Item	Major components	Material & Specification	Grade	Remark
7 1	Fan housing	PBT 70% + Fiber 30%	94V 0	
7 2	Fan blade	PBT 85% + Fiber 15%	94V 0	
7 3	Stator core	Stainless steel (SUS420J2)		
7 4	Bearing	Ball bearing or sleeve bearing (C14-C17) 2100		Two Ball bearing
7 5	Rubber magnet	Sinterium ferrite (BOB 14W)		
7 6	Silicon steel strip	(H23) (H 8)		
7 7	Enamelled copper wires	Material & Specification 0.22 0.23mm	MW 2 UEW	Heat resistance 120°C
7 8	Printed Circuit Board	Wiring printed single layer board	94V 0	
7 9	Lead wires	Polyvinyl Chloride enamelled copper wires (AWG#22)	94V 0	Red wire: polarity Black wire: polarity
7 10	Label	Polyester		

8 · Product inspection procedure

Inspection procedures below are extremely followed

- 8 1 · 100% Electric, rotating, dead spot, fan blade fasten, and primary noise test on production line
- 8 2 · 100% Current wave test with scope on production line
- 8 3 · 100% Strike test by hand and noise filter in quiet room
- 8 4 · 10 cm drop test at random in accordance with MIL STD 105E standard
- 8 5 · Random inspection in accordance with MIL STD 105E standard
- 8 6 · Pass/Reject standard:
Critical AQL:0.4 Major AQL:0.65 Minor AQL:1.0

9 · Notes:

- 9 1 · We will not guarantee the products if the application of our products are exceeded the limitation which is specified on this specification
- 9 2 · In case of changes of the specification specified on this document A written notice is requested in advance
- 9 3 · Please do not touch the impeller with the pressure and never bring the fan with lead wire The bearing and lead wire may be damaged
- 9 4 · No guarantee on the products against the safety problem or failure caused by powder dust or insect
- 9 5 · If there is any data or related documentation different from this data sheet This data sheet is the principle reference
- 9 6 · Please do not use the fan in the environment of corrosive liquid or detrimental gas
- 9 7 · Please do not store the fan in the environment of high/low temperature or detrimental gas
- 9 8 · While the fan is in operation, please do not lock the fan intentionally for a long periods of time, since the continuous stoppage will result in overheat and thus burnt out the fan
- 9 9 · During the installation of the fan, please pay substantial attention to possible notice caused by resonance vibration and shock

It is very important to notify that avoid to drop from 60cm height when in any movement or operation it will impact the balance of blade Especially ball bearing structure is avoided to drop down

The torque of the screw which locked the frame should not exceed 4 Kgf

10 · RPM detection

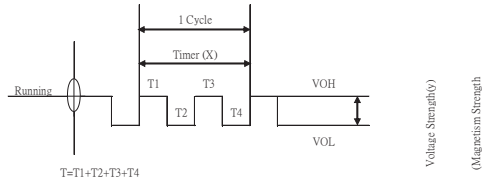

- 1 · Output waveform:square wave
- 2 · When the voltage value is higher (Voltage Y) then output waveform is higher
- 3 · When the fan is shutdown then output waveform is a horizontal line
- 4 · The cyclic distance is longer then the RPM is Slower
- 5 · RPM formula as follows:

$$RPM = \frac{4200}{X(ns)}$$

Example

X=15ns

Ls=1000ns

Lmin=4200ns

$$RPM = \frac{4200}{15} = 2800$$

11 · Installation drawing

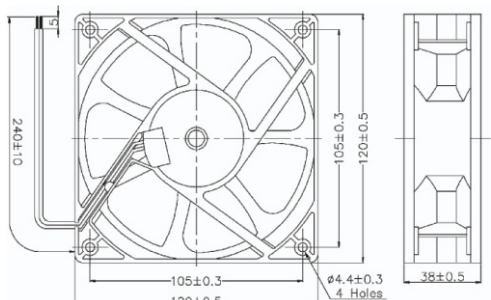

- 1 · Mechanical
- 1 1 · External dimension 120*120*38mm
- 1 2 · Weight 246g/pcs (Lead wire length x 300mm & without connector)
- 1 3 · Bearing Two Ball bearing
- 2 · Electrical characteristics(in free air at rated voltage)
- 2 1 · Rated voltage 12V
- 2 2 · Rated current 0.08±10%A
- 2 3 · Rated input power 0.96±10%W
- 3 · Efficiency
- 3 1 · Rated speed(range) 1500RPM±10%
- 3 2 · Maximum air flow 65 CFM
- 3 3 · Maximum static air pressure 2.2mm H2O
- 4 · Characteristics
- 4 1 · Operating voltage range 7.5V 13.8V
- 4 2 · Starting voltage 7.5V(ON/OFF)
- 4 3 · Locked current 0.16A(Reference)
- 4 4 · Operating temperature 10°C +70°C
- 4 5 · Storage temperature 30°C +85°C
- 4 6 · Waterproof class Grade IP58 to an immersion depth of 1.0 metre in water
- 4 8 · Insulation resistance At least 10MΩ at 500 VDC between housing and both lead wires
- 4 9 · Dielectric strength Withstand 500 VAC 1 minute 1mA between housing and both lead wires
- 4 10 · MTBF : 50,000Hours
Life expectancy:50,000Hours continuous operation at rated voltage and normal temperature & humidity
- 4 11 · Tensile strength of connector Connector will not be any broken at 1 Kg for 15 seconds per piece
- 4 12 · Acoustic sound level 27.0dBA(Max 27.0dBA)
- 4 12 1 · Acoustic sound level test descriptions

At rated voltage in sound proof room

Background noise:14.9dBA

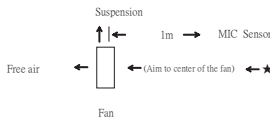

4 13 · Characteristics definition:

4 13 1 · Rated current, rated speed, and rated input power shall reach bottom line of specification after 5 minutes continuous rotation at rated voltage and reach standard specification after 10 minutes continuous at rated voltage

4 13 2 · Starting voltage is the least voltage that enables to start the fan by sudden power on

5 · Protection:

Reversal voltage test: We took 200pcs for reversal voltage test at 12V for 1 minutes and all remain still Fans work normally after corrected voltage

6 · Safety	UL	CE	RoHS
		✓	✓

7 · Material

Item	Major components	Material & Specification	Grade	Remark
7 1	Fan housing	PBT 70% + Fiber 30%	94V 0	
7 2	Fan blade	PBT 85% + Fiber 15%	94V 0	
7 3	Stator core	Stainless steel (SUS420J2)		
7 4	Bearing	Ball bearing or sleeve bearing (C1+G1,T) 2100		Two Ball bearing
7 5	Rubber magnet	Sinterium ferrite (BOB 14W)		
7 6	Silicon steel strip	(H23) (H 8)		
7 7	Enamelled copper wires	Material & Specification 0.22 0.23mm	MW 2 UEW	Heat resistance 120°C
7 8	Printed Circuit Board	Wiring printed single layer board	94V 0	
7 9	Lead wires	Polyvinyl Chloride enamelled copper wires (AWG#22)	94V 0	Red wire: polarity Black wire: polarity
7 10	Label	Polyester		

8 · Product inspection procedure

Inspection procedures below are extremely followed

8 1 · 100% Electric, rotating, dead spot, fan blade fasten, and primary noise test on production line

8 2 · 100% Current wave test with scope on production line

8 3 · 100% Strike test by hand and noise filter in quiet room

8 4 · 10 cm drop test at random in accordance with MIL STD 105E standard

8 5 · Random inspection in accordance with MIL STD 105E standard

8 6 · Pass/Reject standard:

Critical AQL:0.4 Major AQL:0.65 Minor AQL:1.0

9 · Notes:

9 1 ·

We will not guarantee the products if the application of our products are exceeded the limitation which is specified on this specification

9 2 ·

In case of changes of the specification specified on this document A written notice is requested in advance

9 3 ·

Please do not touch the impeller with the pressure and never bring the fan with lead wire The bearing and lead wire may be damaged

9 4 ·

No guarantee on the products against the safety problem or failure caused by powder dust or insect

9 5 ·

If there is any data or related documentation different from this data sheet This data sheet is the principle reference

9 6 ·

Please do not use the fan in the environment of corrosive liquid or detrimental gas

9 7 ·

Please do not store the fan in the environment of high/low temperature or detrimental gas

9 8 ·

While the fan is in operation, please do not lock the fan intentionally for a long periods of time, since the continuous stoppage will result in overheat and thus burnt out the fan

9 9 ·

During the installation of the fan, please pay substantial attention to possible notice caused by resonance vibration and shock

9 10 ·

It is very important to notify that avoid to drop from 60cm height when in any movement or operation it will impact the balance of blade Especially ball bearing structure is avoided to drop down

9 11 ·

The torque of the screw which locked the frame should not exceed 4 Kgf

10 · RPM detection

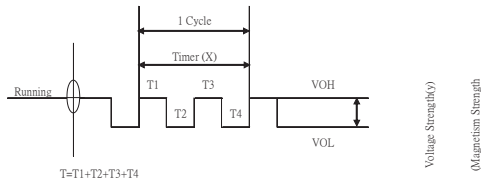

1 · Output waveform:square wave

2 · When the voltage value is higher (Voltage Y) then output waveform is higher

3 · When the fan is shutdown then output waveform is a horizontal line

4 · The cyclic distance is longer then the RPM is Slower

5 · RPM formula as follows:

$$RPM = \frac{2250}{X(ns)}$$

Example

X=15ns

Ls=1000ns

Lmin=22500ns

$$RPM = \frac{2250}{15} = 1500$$

11 · Installation drawing

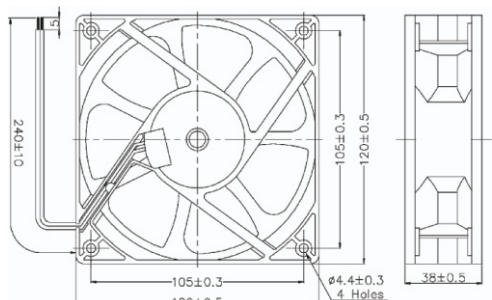

- 1 · Mechanical
- 1 1 · External dimension 120*120*38mm
- 1 2 · Weight 246g/pcs (Lead wire length x 300mm & without connector)
- 1 3 · Bearing Two Ball bearing
- 2 · Electrical characteristic(s) in free air at rated voltage)
 - 2 1 · Rated voltage 12V
 - 2 2 · Rated current 0.16±10%A
 - 2 3 · Rated input power 1.92±10%W
- 3 · Efficiency
 - 3 1 · Rated speed (range) 1950RPM±10%
 - 3 2 · Maximum air flow 83 CFM
 - 3 3 · Maximum static air pressure 4.72mm H2O
- 4 · Characteristics
 - 4 1 · Operating voltage range 7.5V 13.8V
 - 4 2 · Starting voltage 7.5V(ON/OFF)
 - 4 3 · Locked current 0.24A(Reference)
 - 4 4 · Operating temperature 10°C +70°C
 - 4 5 · Storage temperature 30°C +85°C
- 4 6 · Waterproof class Grade IP58 to an immersion depth of 1.0 metre in water
- 4 8 · Insulation resistance At least 10MΩ at 500 VDC between housing and both lead wires
- 4 9 · Dielectric strength Withstand 500 VAC 1 minute 1mA between housing and both lead wires
- 4 10 · MTBF : 50,000Hours
Life expectancy:50,000Hours continuous operation at rated voltage and normal temperature & humidity
- 4 11 · Tensile strength of connector Connector will not be any broken at 1 Kg for 15 seconds per piece
- 4 12 · Acoustic sound level 34.00dBA(Max 34.00dBA)
- 4 12 1 · Acoustic sound level test descriptions

At rated voltage in sound proof room

Background noise:14.9dBA

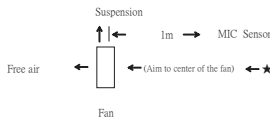

4 13 · Characteristics definition:

- 4 13 1 · Rated current, rated speed, and rated input power shall reach bottom line of specification after 5 minutes continuous rotation at rated voltage and reach standard specification after 10 minutes continuous at rated voltage
- 4 13 2 · Starting voltage is the least voltage that enables to start the fan by sudden power on

5 · Protection:

Reversal voltage test: We took 200pcs for reversal voltage test at 12V for 1 minutes and all remain still Fans work normally after corrected voltage

6 · Safety	UL	CE	RoHS
		✓	✓

7 · Material

Item	Major components	Material & Specification	Grade	Remark
7 1	Fan housing	PBT 70% + Fiber 30%	94V 0	
7 2	Fan blade	PBT 85% + Fiber 15%	94V 0	
7 3	Stator core	Stainless steel (SUS420I2)		
7 4	Bearing	Ball bearing or sleeve bearing (C1+G1) T1 2100		Two Ball bearing
7 5	Rubber magnet	Sinterium ferrite (BOB 14W)		
7 6	Silicon steel strip	(H23) (H 8)		
7 7	Enamelled copper wires	Material & Specification 0.22 0.23mm	MW 2 UEW	Heat resistance 120°C
7 8	Printed Circuit Board	Wiring printed single layer board	94V 0	CAM 1 T:0.8mm
7 9	Lead wires	Polyvinyl Chloride enamelled copper wires (AWG#22)	94V 0	Red wire: polarity Black wire: polarity
7 10	Label	Polyester		

8 · Product inspection procedure

Inspection procedures below are extremely followed

- 8 1 · 100% Electric, rotating, dead spot, fan blade fasten, and primary noise test on production line
- 8 2 · 100% Current wave test with scope on production line
- 8 3 · 100% Strike test by hand and noise filter in quiet room
- 8 4 · 10 cm drop test at random in accordance with MIL STD 105E standard
- 8 5 · Random inspection in accordance with MIL STD 105E standard
- 8 6 · Pass/Reject standard:
Critical AQL:0.4 Major AQL:0.65 Minor AQL:1.0

9 · Notes:

9 1 ·

We will not guarantee the products if the application of our products are exceeded the limitation which is specified on this specification

9 2 ·

In case of changes of the specification specified on this document A written notice is requested in advance

9 3 ·

Please do not touch the impeller with the pressure and never bring the fan with lead wire The bearing and lead wire may be damaged

9 4 ·

No guarantee on the products against the safety problem or failure caused by powder dust or insect

9 5 ·

If there is any data or related documentation different from this data sheet This data sheet is the principle reference

9 6 ·

Please do not use the fan in the environment of corrosive liquid or detrimental gas

9 7 ·

Please do not store the fan in the environment of high/low temperature or detrimental gas

9 8 ·

While the fan is in operation, please do not lock the fan intentionally for a long periods of time, since the continuous stoppage will result in overheat and thus burnt out the fan

9 9 ·

During the installation of the fan, please pay substantial attention to possible noise caused by resonance vibration and shock

9 10 ·

It is very important to notify that avoid to drop from 60cm height when in any movement or operation it will impact the balance of blade Especially ball bearing structure is avoided to drop down

9 11 ·

The torque of the screw which locked the frame should not exceed 4 Kgf

10 · RPM detection

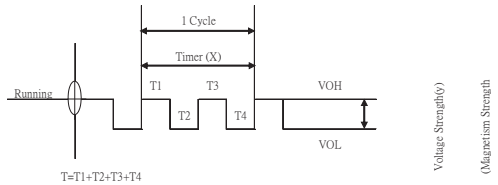

1 · Output waveform: square wave

2 · When the voltage value is higher (Voltage Y) then output waveform is higher

3 · When the fan is shutdown then output waveform is a horizontal line

4 · The cyclic distance is longer then the RPM is Slower

5 · RPM formula as follows:

$$RPM = \frac{2925}{X(ns)}$$

Example

$$X = 15ns$$

$$Ls = 1000ns$$

$$Lmin = 292500ns$$

$$RPM = \frac{2925}{15} = 1950$$

11 · Installation drawing

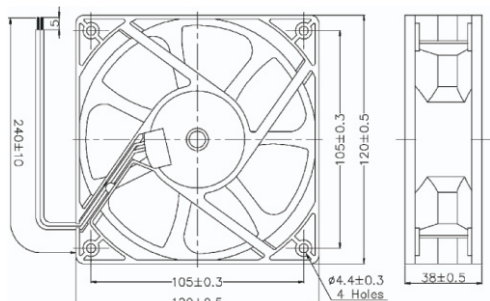

- 1 · Mechanical
- 1 1 · External dimension 120*120*38mm
- 1 2 · Weight 246g/pcs (Lead wire length x 300mm & without connector)
- 1 3 · Bearing Two Ball bearing
- 2 · Electrical characteristics(in free air at rated voltage)
- 2 1 · Rated voltage 12V
- 2 2 · Rated current 0.37±10%A
- 2 3 · Rated input power 4.44±10%W
- 3 · Efficiency
- 3 1 · Rated speed(range) 2540RPM±10%
- 3 2 · Maximum air flow 101.3CFM
- 3 3 · Maximum static air pressure 7.66mm H2O
- 4 · Characteristics
- 4 1 · Operating voltage range 7.5V 13.8V
- 4 2 · Starting voltage 7.5V(ON/OFF)
- 4 3 · Locked current 0.46A(Reference)
- 4 4 · Operating temperature 10°C +70°C
- 4 5 · Storage temperature 30°C +85°C

- 4 6 · Waterproof class Grade IP58 to an immersion depth of 1.0 metre in water
- 4 8 · Insulation resistance At least 10MΩ at 500 VDC between housing and both lead wires
- 4 9 · Dielectric strength Withstand 500 VAC 1 minute 1mA between housing and both lead wires
- 4 10 · MTBF : 50,000Hours
Life expectancy:50,000Hours continuous operation at rated voltage and normal temperature & humidity
- 4 11 · Tensile strength of connector Connector will not be any broken at 1 Kg for 15 seconds per piece
- 4 12 · Acoustic sound level 41.0dBA(Max 41.0dBA)

4 12 1 · Acoustic sound level test descriptions

At rated voltage in sound proof room

Background noise:14.9dBA

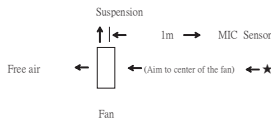

4 13 · Characteristics definition:

- 4 13 1 · Rated current, rated speed, and rated input power shall reach bottom line of specification after 5 minutes continuous rotation at rated voltage and reach standard specification after 10 minutes continuous at rated voltage
- 4 13 2 · Starting voltage is the least voltage that enables to start the fan by sudden power on

5 · Protection:

Reversal voltage test: We took 200pcs for reversal voltage test at 12V for 1 minutes and all remain still Fans work normally after corrected voltage

6 · Safety	UL	CE	RoHS
		✓	✓

7 · Material

Item	Major components	Material & Specification	Grade	Rmark
7 1	Fan housing	PBT 70% + Fiber 30%	94V 0	
7 2	Fan blade	PBT 85% + Fiber 15%	94V 0	
7 3	Stator core	Stainless steel (SUS420J2)		
7 4	Bearing	Ball bearing or sleeve bearing (C14-C17) 2100		Two Ball bearing
7 5	Rubber magnet	Sinterium ferrite (BOB 14W)		
7 6	Silicon steel strip	(H23) (H 8)		
7 7	Enamelled copper wires	Material & Specification 0.22 0.23mm	MW 2 UEW	Heat resistance 120°C
7 8	Printed Circuit Board	Wiring printed single layer board	94V 0	CAM 1 T:0.8mm
7 9	Lead wires	Polyvinyl Chloride enamelled copper wires (AWG#22)	94V 0	Red wire: polarity Black wire: polarity
7 10	Label	Polyester		

8 · Product inspection procedure

Inspection procedures below are extremely followed

- 8 1 · 100% Electric, rotating, dead spot, fan blade fasten, and primary noise test on production line
- 8 2 · 100% Current wave test with scope on production line
- 8 3 · 100% Strike test by hand and noise filter in quiet room
- 8 4 · 10 cm drop test at random in accordance with MIL STD 105E standard
- 8 5 · Random inspection in accordance with MIL STD 105E standard
- 8 6 · Pass/Reject standard:
Critical AQL:0.4 Major AQL:0.65 Minor AQL:1.0

9 · Notes:

- 9 1 · We will not guarantee the products if the application of our products are exceeded the limitation which is specified on this specification
- 9 2 · In case of changes of the specification specified on this document A written notice is requested in advance
- 9 3 · Please do not touch the impeller with the pressure and never bring the fan with lead wire The bearing and lead wire may be damaged
- 9 4 · No guarantee on the products against the safety problem or failure caused by powder dust or insect
- 9 5 · If there is any data or related documentation different from this data sheet This data sheet is the principle reference
- 9 6 · Please do not use the fan in the environment of corrosive liquid or detrimental gas
- 9 7 · Please do not store the fan in the environment of high/low temperature or detrimental gas
- 9 8 · While the fan is in operation, please do not lock the fan intentionally for a long periods of time, since the continuous stoppage will result in overheat and thus burnt out the fan
- 9 9 · During the installation of the fan, please pay substantial attention to possible noise caused by resonance vibration and shock

It is very important to notify that avoid to drop from 60cm height when in any movement or operation it will impact the balance of blade Especially ball bearing structure is avoided to drop down

The torque of the screw which locked the frame should not exceed 4 Kgf

10 · RPM detection

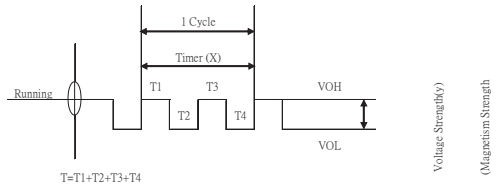

1 · Output waveform:square wave

- 2 · When the voltage value is higher (Voltage Y) then output waveform is higher
- 3 · When the fan is shutdown then output waveform is a horizontal line
- 4 · The cyclic distance is longer then the RPM is Slower

5 · RPM formula as follows:

$$RPM = \frac{3810}{X(ns)}$$

Example

$$X=15ns$$

$$Ls=1000ns$$

$$Lmin=38100ns$$

$$RPM = \frac{3810}{15} = 2540$$

11 · Installation drawing

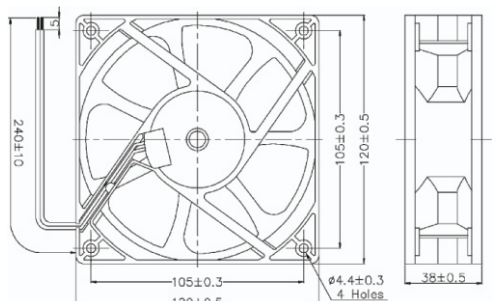

- 1 · Mechanical
- 1 1 · External dimension 120*120*38mm
- 1 2 · Weight 246g/pcs (Lead wire length x 300mm & without connector)
- 1 3 · Bearing Two Ball bearing
- 2 · Electrical characteristics(in free air at rated voltage)
- 2 1 · Rated voltage 24V
- 2 2 · Rated current 0.26±10%A
- 2 3 · Rated input power 6.24±10%W
- 3 · Efficiency
- 3 1 · Rated speed (range) 2800RPM±10%
- 3 2 · Maximum air flow 113.9CFM
- 3 3 · Maximum static air pressure 8.66mm H2O
- 4 · Characteristics
- 4 1 · Operating voltage range 14V-28V
- 4 2 · Starting voltage 14V(ON/OFF)
- 4 3 · Locked current 0.31A(Reference)
- 4 4 · Operating temperature 10°C +70°C
- 4 5 · Storage temperature 30°C +85°C
- 4 6 · Waterproof class Grade IP58 to an immersion depth of 1.0 metre in water
- 4 8 · Insulation resistance At least 10MΩ at 500 VDC between housing and both lead wires
- 4 9 · Dielectric strength Withstand 500 VAC 1 minute 1mA between housing and both lead wires
- 4 10 · MTBF : 50,000Hours
Life expectancy:50,000Hours continuous operation at rated voltage and normal temperature & humidity
- 4 11 · Tensile strength of connector Connector will not be any broken at 1 Kg for 15 seconds per piece
- 4 12 · Acoustic sound level 44.6dBA(Max 44.6dBA)
- 4 12 1 · Acoustic sound level test descriptions

At rated voltage in sound proof room

Background noise:14.9dBA

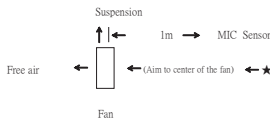

4 13 · Characteristics definition:

4 13 1 · Rated current, rated speed, and rated input power shall reach bottom line of specification after 5 minutes continuous rotation at rated voltage and reach standard specification after 10 minutes continuous at rated voltage

4 13 2 · Starting voltage is the least voltage that enables to start the fan by sudden power on

5 · Protection:

Reversal voltage test: We took 200pcs for reversal voltage test at 24V for 1 minutes and all remain still Fans work normally after corrected voltage

6 · Safety	UL	CE	RoHS
		✓	✓

7 · Material

Item	Major components	Material & Specification	Grade	Rmark
7 1	Fan housing	PBT 70% + Fiber 30%	94V 0	
7 2	Fan blade	PBT 85% + Fiber 15%	94V 0	
7 3	Stator core	Stainless steel (SUS420J2)		
7 4	Bearing	Ball bearing or sleeve bearing (C14-C17) 2100		Two Ball bearing
7 5	Rubber magnet	Sinterium ferrite (BOB 14W)		
7 6	Silicon steel strip	(H23) (H 8)		
7 7	Enamelled copper wires	Material & Specification 0.22 0.23mm	MW 2 UEW	Heat resistance 120°C
7 8	Printed Circuit Board	Wiring printed single layer board	94V 0	CAM 1 T:0.8mm
7 9	Lead wires	Polyvinyl Chloride enamelled copper wires (AWG#22)	94V 0	Red wire: polarity Black wire: polarity
7 10	Label	Polyester		

8 · Product inspection procedure

Inspection procedures below are extremely followed

8 1 · 100% Electric, rotating, dead spot, fan blade fasten, and primary noise test on production line

8 2 · 100% Current wave test with scope on production line

8 3 · 100% Strike test by hand and noise filter in quiet room

8 4 · 10 cm drop test at random in accordance with MIL STD 105E standard

8 5 · Random inspection in accordance with MIL STD 105E standard

8 6 · Pass/Reject standard:

Critical AQL:0.4 Major AQL:0.65 Minor AQL:1.0

9 · Notes:

9 1 ·

We will not guarantee the products if the application of our products are exceeded the limitation which is specified on this specification

9 2 ·

In case of changes of the specification specified on this document A written notice is requested in advance

9 3 ·

Please do not touch the impeller with the pressure and never bring the fan with lead wire The bearing and lead wire may be damaged

9 4 ·

No guarantee on the products against the safety problem or failure caused by powder dust or insect

9 5 ·

If there is any data or related documentation different from this data sheet This data sheet is the principle reference

9 6 ·

Please do not use the fan in the environment of corrosive liquid or detrimental gas

9 7 ·

Please do not store the fan in the environment of high/low temperature or detrimental gas

9 8 ·

While the fan is in operation, please do not lock the fan intentionally for a long periods of time, since the continuous stoppage will result in overheat and thus burnt out the fan

9 9 ·

During the installation of the fan, please pay substantial attention to possible notice caused by resonance vibration and shock

9 10 ·

It is very important to notify that avoid to drop from 60cm height when in any movement or operation it will impact the balance of blade Especially ball bearing structure is avoided to drop down

9 11 ·

The torque of the screw which locked the frame should not exceed 4 Kgf

10 · RPM detection

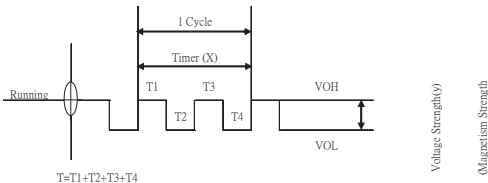

1 · Output waveform:square wave

2 · When the voltage value is higher (Voltage Y) then output waveform is higher

3 · When the fan is shutdown then output waveform is a horizontal line

4 · The cyclic distance is longer then the RPM is Slower

5 · RPM formula as follows:

$$RPM = \frac{4200}{X(ns)}$$

Example

X=15ns

Ls=1000ns

Lmin=42000ns

$$RPM = \frac{4200}{15} = 2800$$

11 · Installation drawing

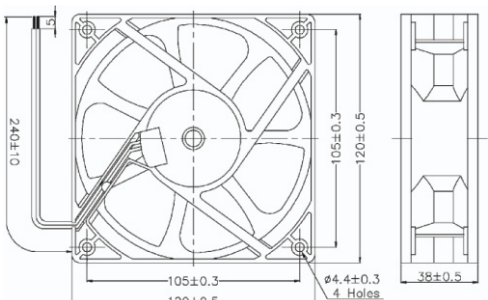

- 1 · Mechanical
- 1.1 · External dimension 120*120*38mm
- 1.2 · Weight 246g/pcs (Lead wire length x 300mm & without connector)
- 1.3 · Bearing Two Ball bearing
- 2 · Electrical characteristics(in free air at rated voltage)
- 2.1 · Rated voltage 24V
- 2.2 · Rated current 0.09±10%A
- 2.3 · Rated input power 2.16±10%W
- 3 · Efficiency
- 3.1 · Rated speed(range) 1500RPM±10%
- 3.2 · Maximum air flow 65.9CFM
- 3.3 · Maximum static air pressure 2.2mm H2O
- 4 · Characteristics
- 4.1 · Operating voltage range 14V 28V
- 4.2 · Starting voltage 14V(ON/OFF)
- 4.3 · Locked current 0.15A(Reference)
- 4.4 · Operating temperature 10°C +70°C
- 4.5 · Storage temperature 30°C +85°C
- 4.6 · Waterproof class Grade IP58 to an immersion depth of 1.0 metre in water
- 4.8 · Insulation resistance At least 10MΩ at 500 VDC between housing and both lead wires
- 4.9 · Dielectric strength Withstand 500 VAC 1 minute 1mA between housing and both lead wires
- 4.10 · MTBF : 50,000Hours
- Life expectancy:50,000Hours continuous operation at rated voltage and normal temperature & humidity
- 4.11 · Tensile strength of connector Connector will not be any broken at 1 Kg for 15 seconds per piece

9 · Notes:

- 9.1 · We will not guarantee the products if the application of our products are exceeded the limitation which is specified on this specification
- 9.2 · In case of changes of the specification specified on this document A written notice is requested in advance
- 9.3 · Please do not touch the impeller with the pressure and never bring the fan with lead wire The bearing and lead wire may be damaged
- 9.4 · No guarantee on the products against the safety problem or failure caused by powder dust or insect
- 9.5 · If there is any data or related documentation different from this data sheet This data sheet is the principle reference
- 9.6 · Please do not use the fan in the environment of corrosive liquid or detrimental gas
- 9.7 · Please do not store the fan in the environment of high/low temperature or detrimental gas
- 9.8 · While the fan is in operation, please do not lock the fan intentionally for a long periods of time, since the continuous stoppage will result in overheat and thus burnt out the fan
- 9.9 · During the installation of the fan, please pay substantial attention to possible noise caused by resonance vibration and shock

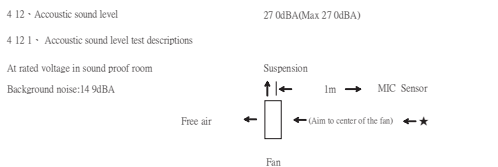

- 4.13 · Characteristics definition:
- 4.13.1 · Rd ed current, rated speed, and rated input shall reach bottom line of specification after 5 minutes continuous rotation at rated voltage and reach standard specification after 10 mins continuous at rated voltage
- 4.13.2 · Starting voltage is the least voltage that enables o start the fan by sudden power on
- 5 · Protection:

Reversal voltage test: We took 200pcs for reversal voltage test at 24V for 1 minutes and all remain still
Fans work normally after corrected voltage

6 · Safety	UL	CE	RoHS
------------	----	----	------

It is very important to notify that avoid to drop from 60cm height when in any movement or operation it will impact the balance of blade. Especially ball bearing structure is avoided to drop down

The torque of the screw which locked the frame should not exceed 4 Kgf

10 · RPM detection

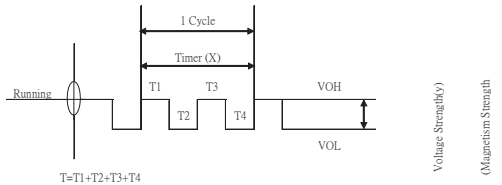

- 1 · Output waveform:square wave
- 2 · When the voltage value is higher (Voltage Y) then output waveform is higher
- 3 · When the fan is shutdown then output waveform is a horizontal line
- 4 · The cyclic distance is longer then the RPM is Slower
- 5 · RPM formula as follows:

$$RPM = \frac{2250}{X(ns)}$$

Example

- X=15ns
- Ls=1000ns
- Lmin=22500ns

$$RPM = \frac{2250}{15} = 1500$$

7 · Material

Item	Major components	Material & Specification	Grade	Rmark
7.1	Fan housing	PBT 70% + Fiber 30%	94V 0	
7.2	Fan blade	PBT 85% + Fiber 15%	94V 0	
7.3	Stator core	Stainless steel (SUS420J2)		
7.4	Bearing	Ball bearing or sleeve bearing (G2+G1) 2100		Two Ball bearing
7.5	Rubber magnet	Sinterium ferrite (BOB 14W)		
7.6	Silicon steel strip	(H23) (H 8)		
7.7	Enamelled copper wires	Material & Specification 0.22 0.23mm	MW 2 UEW	Heat resistance 120°C
7.8	Printed Circuit Board	Wiring printed single layer board	94V 0	CAM 1 T:0.8mm
7.9	Lead wires	Polyvinyl Chloride enamelled copper wires (AWG#22)	94V 0	Red wire: polarity Black wire: polarity
7.10	Label	Polyester		

8 · Product inspection procedure

- Inspection procedures below are extremely followed
- 8.1 · 100% Electric, rotating, dead spot, fan blade fasten, and primary noise test on production line
- 8.2 · 100% Current wave test with scope on production line
- 8.3 · 100% Strike test by hand and noise filter in quiet room
- 8.4 · 10 cm drop test at random in accordance with MIL STD 105E standard
- 8.5 · Random inspection in accordance with MIL STD 105E standard
- 8.6 · Pass/Reject standard:
Critical AQL:0.4 Major AQL:0.65 Minor AQL:1.0

11 · Installation drawing

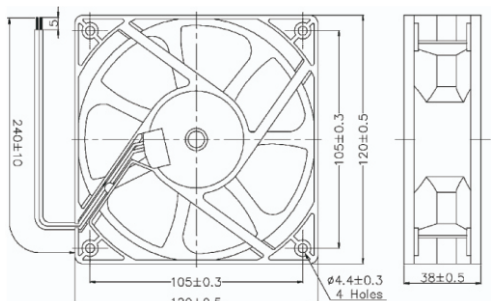

- 1 · Mechanical
- 1 1 · External dimension 120*120*38mm
- 1 2 · Weight 246g/pcs (Lead wire length x 300mm & without connector)
- 1 3 · Bearing Two Ball bearing
- 2 · Electrical characteristics(in free air at rated voltage)
- 2 1 · Rated voltage 24V
- 2 2 · Rated current 0.13±10% A
- 2 3 · Rated input power 3.12±10% W
- 3 · Efficiency
- 3 1 · Rated speed (range) 1950RPM±10%
- 3 2 · Maximum air flow 83 CFM
- 3 3 · Maximum static air pressure 4.72mm H2O
- 4 · Characteristics
- 4 1 · Operating voltage range 14V 28V
- 4 2 · Starting voltage 14V(ON/OFF)
- 4 3 · Locked current 0.22A(Reference)
- 4 4 · Operating temperature 10°C +70°C
- 4 5 · Storage temperature 30°C +85°C

- 4 6 · Waterproof class Grade IP58 to an immersion depth of 1.0 metre in water
- 4 8 · Insulation resistance At least 10MΩ at 500 VDC between housing and both lead wires
- 4 9 · Dielectric strength Withstand 500 VAC 1 minute 1mA between housing and both lead wires
- 4 10 · MTBF : 50,000Hours
Life expectancy:50,000Hours continuous operation at rated voltage and normal temperature & humidity
- 4 11 · Tensile strength of connector Connector will not be any broken at 1 Kg for 15 seconds per piece
- 4 12 · Acoustic sound level 34.0dB(A)Max 34.0dB(A)
- 4 12 1 · Acoustic sound level test descriptions

At rated voltage in sound proof room

Background noise:14.9dBA

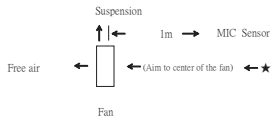

4 13 · Characteristics definition:

- 4 13 1 · Rated current, rated speed, and rated input power shall reach bottom line of specification after 5 minutes continuous rotation at rated voltage and reach standard specification after 10 minutes continuous at rated voltage
- 4 13 2 · Starting voltage is the least voltage that enables to start the fan by sudden power on

5 · Protection:

Reversal voltage test: We took 200pcs for reversal voltage test at 24V for 1 minutes and all remain still Fans work normally after corrected voltage

6 · Safety	UL	CE	RoHS
		✓	✓

7 · Material

Item	Major components	Material & Specification	Grade	Remark
7 1	Fan housing	PBT 70% + Fiber 30%	94V 0	
7 2	Fan blade	PBT 85% + Fiber 15%	94V 0	
7 3	Stator core	Stainless steel (SUS420J2)		
7 4	Bearing	Ball bearing or sleeve bearing (C14-C17) 2100		Two Ball bearing
7 5	Rubber magnet	Sinterium ferrite (BOB 14W)		
7 6	Silicon steel strip	(H23) (H 8)		
7 7	Enamelled copper wires	Material & Specification 0.22 0.23mm	MW 2 UEW	Heat resistance 120°C
7 8	Printed Circuit Board	Wiring printed single layer board	94V 0	
7 9	Lead wires	Polyvinyl Chloride enamelled copper wires (AWG#22)	94V 0	Red wire: polarity Black wire: polarity
7 10	Label	Polyester		

8 · Product inspection procedure

Inspection procedures below are extremely followed

- 8 1 · 100% Electric, rotating, dead spot, fan blade fasten, and primary noise test on production line
- 8 2 · 100% Current wave test with scope on production line
- 8 3 · 100% Strike test by hand and noise filter in quiet room
- 8 4 · 10 cm drop test at random in accordance with MIL STD 105E standard
- 8 5 · Random inspection in accordance with MIL STD 105E standard

8 6 · Pass/Reject standard:

Critical AQL:0.4 Major AQL:0.65 Minor AQL:1.0

9 · Notes:

9 1 ·

We will not guarantee the products if the application of our products are exceeded the limitation which is specified on this specification

9 2 ·

In case of changes of the specification specified on this document A written notice is requested in advance

9 3 ·

Please do not touch the impeller with the pressure and never bring the fan with lead wire The bearing and lead wire may be damaged

9 4 ·

No guarantee on the products against the safety problem or failure caused by powder dust or insect

9 5 ·

If there is any data or related documentation different from this data sheet This data sheet is the principle reference

9 6 ·

Please do not use the fan in the environment of corrosive liquid or detrimental gas

9 7 ·

Please do not store the fan in the environment of high/low temperature or detrimental gas

9 8 ·

While the fan is in operation, please do not lock the fan intentionally for a long periods of time, since the continuous stoppage will result in overheat and thus burnt out the fan

9 9 ·

During the installation of the fan, please pay substantial attention to possible notice caused by resonance vibration and shock

9 10 ·

It is very important to notify that avoid to drop from 60cm height when in any movement or operation it will impact the balance of blade Especially ball bearing structure is avoided to drop down

9 11 ·

The torque of the screw which locked the frame should not exceed 4 Kgf

10 · RPM detection

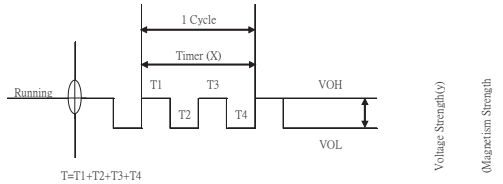

1 · Output waveform:square wave

2 · When the voltage value is higher (Voltage Y) then output waveform is higher

3 · When the fan is shutdown then output waveform is a horizontal line

4 · The cyclic distance is longer then the RPM is Slower

5 · RPM formula as follows:

$$RPM = \frac{2925}{X(ns)}$$

Example

$$X=15ns$$

$$Ls=1000ns$$

$$Lmin=29250ns$$

$$RPM = \frac{2925}{15} = 1950$$

11 · Installation drawing

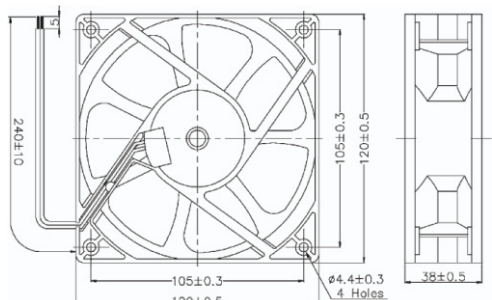

- 1 · Mechanical
- 1 1 · External dimension 120*120*38mm
- 1 2 · Weight 246g/pcs (Lead wire length x 300mm & without connector)
- 1 3 · Bearing Two Ball bearing
- 2 · Electrical characteristics(in free air at rated voltage)
- 2 1 · Rated voltage 24V
- 2 2 · Rated current 0.21±10%A
- 2 3 · Rated input power 5.04±10%W
- 3 · Efficiency
- 3 1 · Rated speed (range) 2540RPM±10%
- 3 2 · Maximum air flow 101 CFM
- 3 3 · Maximum static air pressure 7.66mm H2O
- 4 · Characteristics
- 4 1 · Operating voltage range 14V 28V
- 4 2 · Starting voltage 14V(ON/OFF)
- 4 3 · Locked current 0.36A(Reference)
- 4 4 · Operating temperature 10°C +70°C
- 4 5 · Storage temperature 30°C +85°C

- 4 6 · Waterproof class Grade IP58 to an immersion depth of 1.0 metre in water
- 4 8 · Insulation resistance At least 10MΩ at 500 VDC between housing and both lead wires
- 4 9 · Dielectric strength Withstand 500 VAC 1 minute 1mA between housing and both lead wires
- 4 10 · MTBF : 50,000Hours
Life expectancy:50,000Hours continuous operation at rated voltage and normal temperature & humidity
- 4 11 · Tensile strength of connector Connector will not be any broken at 1 Kg for 15 seconds per piece
- 4 12 · Acoustic sound level 41.0dB(A)(Max 41.0dB(A))

4 12 1 · Acoustic sound level test descriptions

At rated voltage in sound proof room
Background noise:14.9dBA

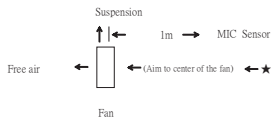

4 13 · Characteristics definition:

- 4 13 1 · Rated current, rated speed, and rated input power shall reach bottom line of specification after 5 minutes continuous rotation at rated voltage and reach standard specification after 10 minutes continuous at rated voltage
- 4 13 2 · Starting voltage is the least voltage that enables to start the fan by sudden power on

5 · Protection:

Reversal voltage test: We took 200pcs for reversal voltage test at 24V for 1 minutes and all remain still
Fans work normally after corrected voltage

	UL	CE	RoHS
6 · Safety		✓	✓

7 · Material

Item	Major components	Material & Specification	Grade	Remark
7 1	Fan housing	PBT 70% + Fiber 30%	94V 0	
7 2	Fan blade	PBT 85% + Fiber 15%	94V 0	
7 3	Stator core	Stainless steel (SUS420J2)		
7 4	Bearing	Ball bearing or sleeve bearing (C14-C17) 2100		Two Ball bearing
7 5	Rubber magnet	Sinterium ferrite (BOB 14W)		
7 6	Silicon steel strip	(H23) (H 8)		
7 7	Enamelled copper wires	Material & Specification 0.22 0.23mm	MW 2 UEW	Heat resistance 120°C
7 8	Printed Circuit Board	Wiring printed single layer board	94V 0	CAM 1 T:0.8mm
7 9	Lead wires	Polyvinyl Chloride enamelled copper wires (AWG#22)	94V 0	Red wire: polarity Black wire: polarity
7 10	Label	Polyester		

8 · Product inspection procedure

- Inspection procedures below are extremely followed
- 8 1 · 100% Electric, rotating, dead spot, fan blade fasten, and primary noise test on production line
- 8 2 · 100% Current wave test with scope on production line
- 8 3 · 100% Strike test by hand and noise filter in quiet room
- 8 4 · 10 cm drop test at random in accordance with MIL STD 105E standard
- 8 5 · Random inspection in accordance with MIL STD 105E standard
- 8 6 · Pass/Reject standard:
Critical AQL:0.4 Major AQL:0.65 Minor AQL:1.0

9 · Notes:

- 9 1 · We will not guarantee the products if the application of our products are exceeded the limitation which is specified on this specification
- 9 2 · In case of changes of the specification specified on this document A written notice is requested in advance
- 9 3 · Please do not touch the impeller with the pressure and never bring the fan with lead wire The bearing and lead wire may be damaged
- 9 4 · No guarantee on the products against the safety problem or failure caused by powder dust or insect
- 9 5 · If there is any data or related documentation different from this data sheet This data sheet is the principle reference
- 9 6 · Please do not use the fan in the environment of corrosive liquid or detrimental gas
- 9 7 · Please do not store the fan in the environment of high/low temperature or detrimental gas
- 9 8 · While the fan is in operation, please do not lock the fan intentionally for a long periods of time, since the continuous stoppage will result in overheat and thus burnt out the fan
- 9 9 · During the installation of the fan, please pay substantial attention to possible notice caused by resonance vibration and shock

It is very important to notify that avoid to drop from 60cm height when in any movement or operation it will impact the balance of blade Especially ball bearing structure is avoided to drop down

The torque of the screw which locked the frame should not exceed 4 Kgf

10 · RPM detection

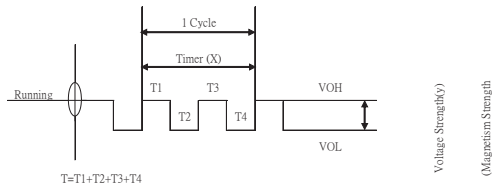

1 · Output waveform:square wave

- 2 · When the voltage value is higher (Voltage Y) then output waveform is higher
- 3 · When the fan is shutdown then output waveform is a horizontal line
- 4 · The cyclic distance is longer then the RPM is Slower
- 5 · RPM formula as follows:

$$RPM = \frac{3810}{X(ns)}$$

Example

- $X = 15ns$
- $Ls = 1000ns$
- $Lmin = 38100ns$

$$RPM = \frac{3810}{15} = 2540$$

11 · Installation drawing

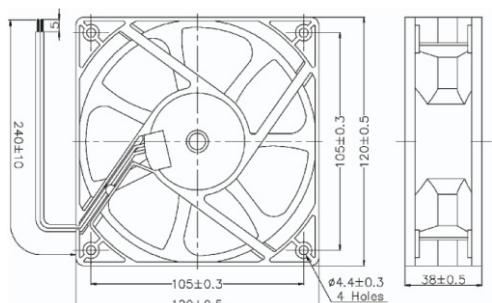

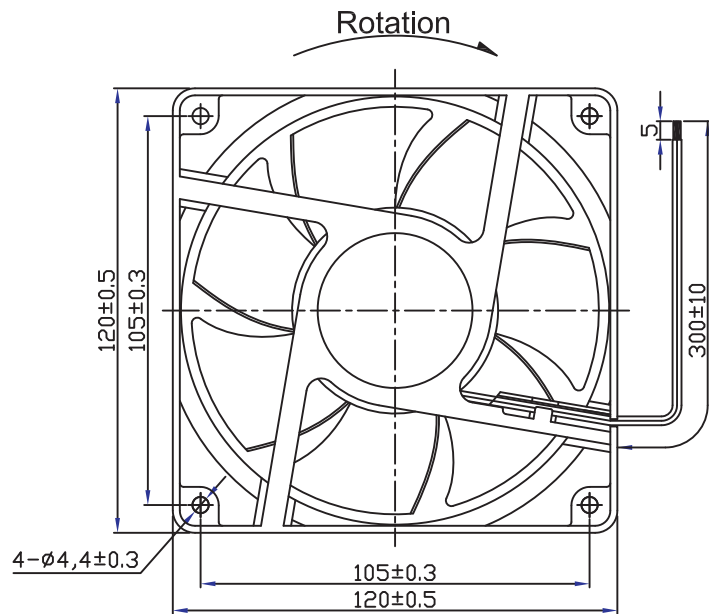
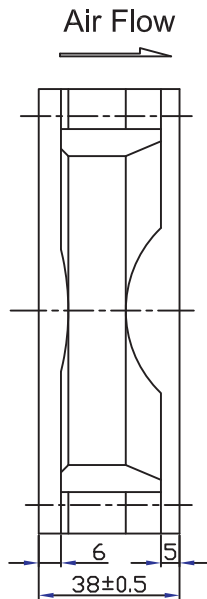
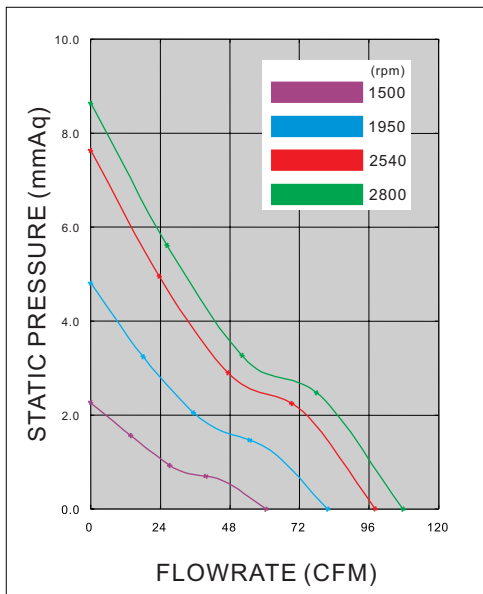

Best-Nr.	Type	Rated Voltage (VDC)	Rated Current (A)	Rated Power (W)	Rated Speed (rpm)	Maximum AirFlow (CFM)	Maximum Pressure (mmAq)	Noise Level (dB/A)
189262	RD12038B12L1	12	0.08	0.96	1500	65.9	2.20	27.0
189261	RD12038B12L	12	0.16	1.92	1950	83.6	4.72	34.0
189263	RD12038B12M	12	0.37	4.44	2540	101.3	7.66	41.0
189259	RD12038B12H	12	0.50	6.0	2800	113.99	8.66	44.6
189266	RD12038B24L1	24	0.09	2.16	1500	65.9	2.20	27.0
189264	RD12038B24L	24	0.13	3.12	1950	83.6	4.72	34.0
189267	RD12038B24M	24	0.21	5.04	2540	101.3	7.66	41.0
189268	RD12038B24H	24	0.26	6.24	2800	113.99	8.66	44.6