

KA1725 Series

HIGH PERFORMANCE AC-FAN

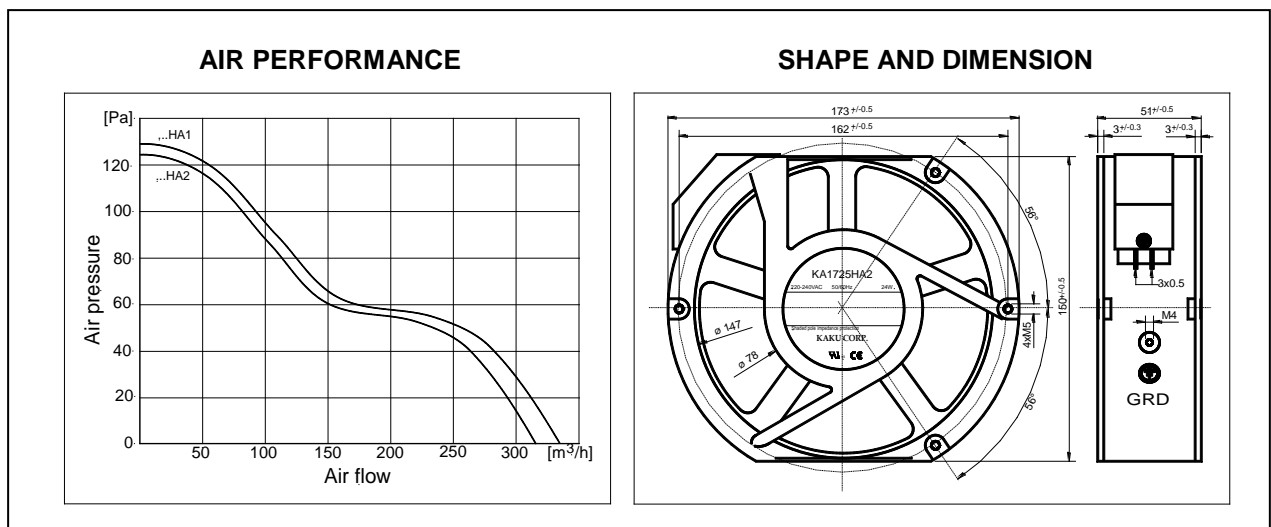

PERFORMANCE

CE		KA1725HA1BMT/Mg [60Hz]	KA1725HA2BMT/Mg [50Hz]
Operating voltage	[VAC]	100 ... 115 ... 127	207...230...253
Typ. power input	[W]	35	32
Max. air flow	[m ³ /h]	335	323
Max. air pressure	[Pa]	129	125
Typ. noise @ 1m distance	[dB(A)]	62	56
Operating temperature	[°C]	-40 ... +80	
Direction of rotation		CW	
Direction of air flow		Over struts	
Life expectancy L ₁₀ /MTTF @ 40°C	[h]	70000/350000	
Typ. rotor speed	[RPM]	2800	2700
Bearing system		2 Ball bearings	
Weight	[g]	470	
Connection		2 terminals 2.8x0.5mm (Lead wires on request)	
Standard packing quantity	[PCs.]	40 - 480	

This **KAKU**[®] AC fan is suitable for industrial use and has a remarkable air flow performance despite its very small dimensions. It is permanently electrically protected against rotor blocking and thermal overloading. Due to the low rotor weight and the precision balancing it has very low vibration and is insensitive to shock.

Further features of this fan are extremely robust and torsionally rigid housing of aluminum the ball bearings made from special steel and the impeller made from Magnesium.

KAKU[®] is the brand name for fans and CPU-cooler, made by KAKU Corp., CN

Technical changes without notice • 11/17