

Total solder points: 187

Difficulty level:

beginner 1 2 3 4 5 advanced

HIGH-Q
velleman-kit 

Code Lock

K6400

Features

- More than 3000 codes possible.
- State indication by LED.
- Pulse or switch output.
- Nine digits of which 4 code digits.
- Secured against polarity reversal.

specifications :

- Power supply : 9 to 15VDC or 8 to 12VAC.
- Relay output : 5A / 220V.
- Time limit for code determination : +/- 5sec.
- Current consumption : Output OFF: 0,3µA
 Output ON : 40mA

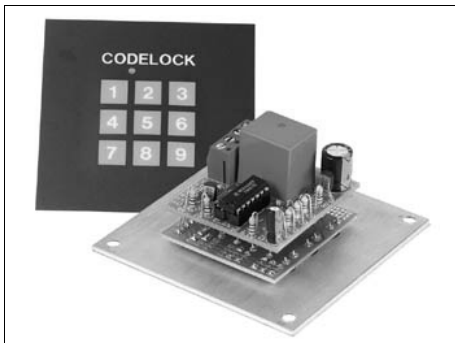





VELLEMAN Components NV
Legen Heirweg 33
9890 Gavere
Belgium
<http://www.velleman.be>
<http://www.velleman-kit.com>

1. Assembly (Skipping this can lead to troubles !)

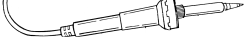
Ok, so we have your attention. These hints will help you to make this project successful. Read them carefully.

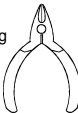
1.1 Make sure you have the right tools:

- A good quality soldering iron (25-40W) with a small tip. 
- Wipe it often on a wet sponge or cloth, to keep it clean; then apply solder to the tip, to give it a wet look. This is called 'thinning' and will protect the tip, and enables you to make good connections. When solder rolls off the tip, it needs cleaning. 
- Thin raisin-core solder. Do not use any flux or grease.
- A diagonal cutter to trim excess wires. To avoid injury when cutting excess leads, hold the lead so they cannot fly towards the eyes. 
- Needle nose pliers, for bending leads, or to hold components in place. 
- Small blade and phillips screwdrivers. A basic range is fine.



For some projects, a basic multi-meter is required, or might be handy

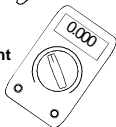

1.2 Assembly Hints :

- ⇒ Make sure the skill level matches your experience, to avoid disappointments.
- ⇒ Follow the instructions carefully. Read and understand the entire step before you perform each operation.
- ⇒ Perform the assembly in the correct order as stated in this manual
- ⇒ Position all parts on the PCB (Printed Circuit Board) as shown on the drawings.
- ⇒ Values on the circuit diagram are subject to changes.
- ⇒ Values in this assembly guide are correct*
- ⇒ Use the check-boxes to mark your progress.
- ⇒ Please read the included information on safety and customer service

* Typographical inaccuracies excluded. Always look for possible last minute manual updates, indicated as 'NOTE' on a separate leaflet.

1.3 Soldering Hints :

Mount the component against the PCB surface and carefully solder the leads

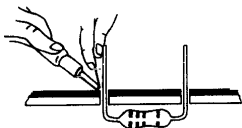

Make sure the solder joints are cone-shaped and shiny



Trim excess leads as close as possible to the solder joint

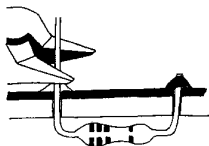

AXIAL COMPONENTS ARE TAPED IN THE CORRECT MOUNTING SEQUENCE !

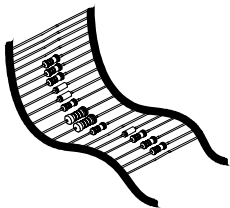

REMOVE THEM FROM THE TAPE ONE AT A TIME !

5%

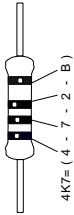

1%

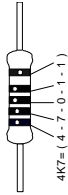

COLOR= 2...5



	I	P	E	SF	S	DK	N	D	GB	F	NL
C O D E	CODICE COLORE	CODIGO DE CORES	CODIGO DE COL- ORES	VÁRI- KOODI	FÁRG SCHEMA	FARVE- KODE	FARGE- KODE	FARB KODE	COLOUR CODE	CODIFI- CATION DES COU- LEURS	KLEUR KODE
0	Nero	Preto	Negro	Musta	Svart	Sort	Sort	Schwarz	Black	Noir	Zwart
1	Marrone	Castanho	Marrón	Ruskea	Brun	Brun	Brun	Braun	Brown	Brun	Bruin
2	Rosso	Encarnado Rojo		Punainen	Röd	Röd	Röd	Rot	Red	Rouge	Rood
3	Aranciato	Laranja	Naranjado	Oranssi	Orange	Orange	Orange	Orange	Orange	Orange	Oranje
4	Giallo	Amarelo	Amarillo	Keltainen	Gul	Gul	Gul	Gelb	Yellow	Jaune	Geel
5	Verde	Verde	Verde	Vihreä	Grön	Grøn	Grønn	Grün	Green	Vert	Groen
6	Blu	Azul	Azul	Sininen	Blå	Blå	Blå	Blau	Blue	Bleu	Blauw
7	Viola	Violeta	Morado	Purppura	Lila	Violet	Violet	Violet	Purple	Violet	Paars
8	Grigio	Cinzeno	Gris	Harmaa	Grå	Grå	Grå	Grau	Grey	Gris	Grijs
9	Bianco	Branco	Blanco	Valkoinen	Vit	Hvid	Hvidt	Weiss	White	Blanc	Wit
A	Argento	Prateado	Plata	Hopea	Silver	Sølv	Sølv	Silber	Silver	Argent	Zilver
B	Oro	Dourado	Oro	Kulta	Guld	Guld	Guldi	Gold	Gold	Or	Goud

This code lock can be used to switch an alarm (e.g. car alarm K3504) on and off as well as to open a door lock. A LED on the operation panel reflects the state of the "lock". You can easily determine the code yourself. Thanks to its reduced dimensions, this code lock is very well suited to be built into a standard housing. Its fully closed operation panel allows it to be used inside as well as outside.

Construction of P6400S

The unit consists out of two PCB's, one is the keyboard module "P6400S" and the other is the master module "P6400B".

First we will start with the Keyboard module, then we assemble the master module.



TIP : The picture on the packaging can be used as a guideline. However, due to possible changes it is not 100% reliable.

1. Push buttons

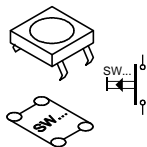

SW1...SW9

2. Leds

Watch the polarity !

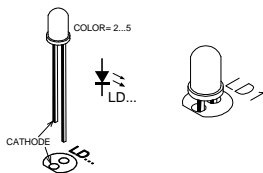

LD1

Determining the code

The four code digits are determined by fitting wire jumpers, see figure 1.0.

Drawing 1.1 shows the connections for code 1234 as an example.

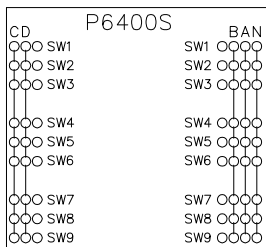

FIG. 1.0

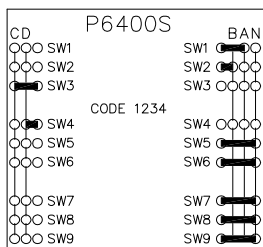

FIG. 1.1

Attention : the wire jumpers that build the code must be as close to the pcb as possible, because otherwise they will touch the aluminium front panel!

The code sequence is determined by connecting the lines A, respectively B, C and D to the connecting terminals (keys 1 through 9) at the inside of the pcb, where line A is the first code, B the second code and so on. The unused keys (normally 5) are connected to line N.

Preparation

Fit seven non insulated wires at the solder side of the pcb. These wires will be used later on for through connection to the master module (see fig. 2.0).



Attention : the wires at the component side must be cut off as close to the pcb as possible.

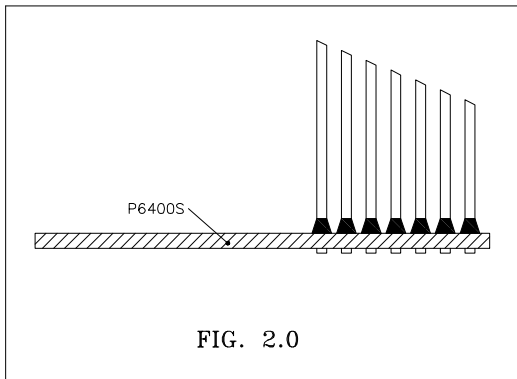

Construction of P6400B**1. Jumpers**

-
- J

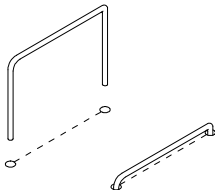
**on/off function of the key lock.**

-
- J1

Fit wire jumper J1 in case you intend to use the **on/off function of the key lock**.

If you don't fit this wire jumper, then, at the input of the code, the code lock will only generate a pulse (in general this mode is used with door locks).

"closed" contact or "open" contact.

-
- NC or NO

Fit wire jumper NC if you intend to use the normally **"closed" contact** of the relay, or wire jumper NO if you intend to use the normally **"open" contact** of the relay.



ATTENTION : after the relay has been fitted, these wire jumpers are no longer accessible.

2. Resistors.

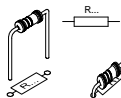

- R8 : 10 (1-0-0-B)
- R9 : 220 (2-2-1-B)
- R11 : 1K5 (1-5-2-B)

3. Diodes

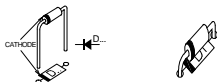

- D1 : 1N4148 or eq.
- D5 : 1N4000



- D2...D4 : 1N4148 or eq

☞ The side with the mark comes in the smallest hole marked C !

4. IC socket, Watch the position of the notch !

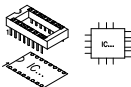

- IC1: 14p

5. Transistors.

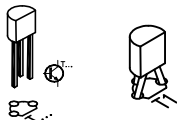

- T1, T2 : BC547B or eq

6. Resistors.



- R1: 470K (4-7-4-B)
- R2...R4 : 47K (4-7-3-B)
- R5...R7 : 10K (1-1-3-B)

7. Electrolytic Capacitors. Watch the polarity !

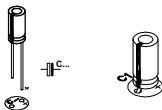

- C1 : 10 μ F
- C2 : 470 μ F

8. Screw connector

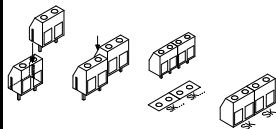

□ J2 : 2 x 2p

9. Relay

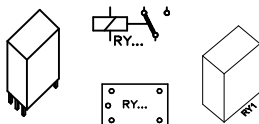

□ RY1 : VR15M121C

10. IC, Check the position of the notch !

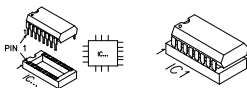

□ IC1: CD4066

Assembly (fig 3.0)



CHECK THE WHOLE MOUNTING ONCE MORE THOROUGHLY AND DON'T FORGET THE CODE, BECAUSE AFTER THE FOLLOWING ASSEMBLY IT WON'T BE ACCESSIBLE ANY MORE.

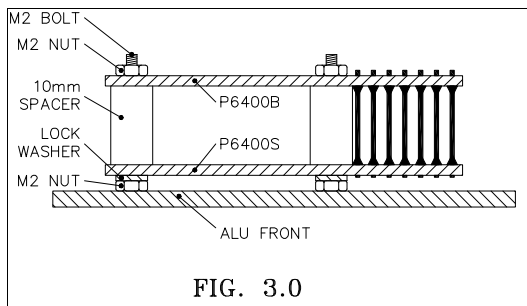

Pass two 2mm bolts through the front panel and fix them using a nut. Then pass a lock washer over the bolts followed by the keyboard module. Take care that the LED is in the front panel. Normally, neither the LED nor the push buttons may pass through the front panel. The push buttons must be flush with the front side.

Pass a 10mm distance tube over the two bolts, followed by the master module. Also take care that the through connections pass through the master module.

Now fix both modules using two nuts, where after you can solder the through connections (pay attention to short-circuits).

Test and Usage

Connect a 9 to 15VDC or a 8 to 12VAC to the points V and GND. (V is the plus pole in the case of direct current). Put the front panel film next to the keyboard and enter the right code (in the case of a pulse output this has to be done within 5 seconds). If everything is going on well, now the relay should close and open again in case pulse output mode has been -selected. If however you have chosen for a constant switch position, then you can cause the relay to open by entering a -digit NOT belonging to the code digits.



Tip: should the opening time of the relay (in the case of the pulse output mode) be too short, fit a 22 μ F capacitor instead of C1 to change that time.

Building in

In case you use the key lock outside, it is advisable to mount it sunk, so that no water can soak in. For safety you better first fix the code lock into the wall where after you stick the film to it, so that the fixation screws are hidden "behind" the film.

Take care that, when sticking the film, the "LED WINDOW" corresponds with the hole in the aluminium.

PCB layout

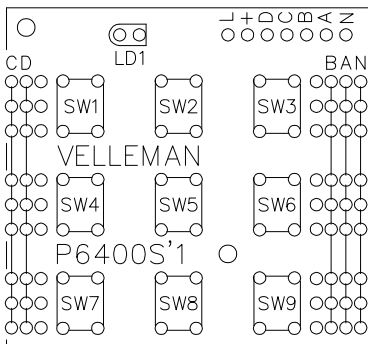

P6400S - Keyboard

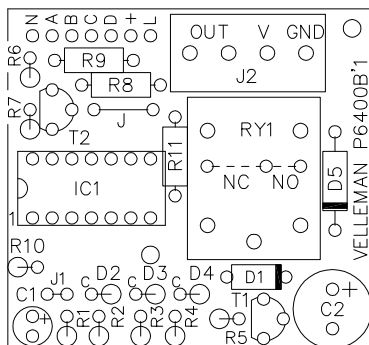

P6400B - master

Schematic diagram.

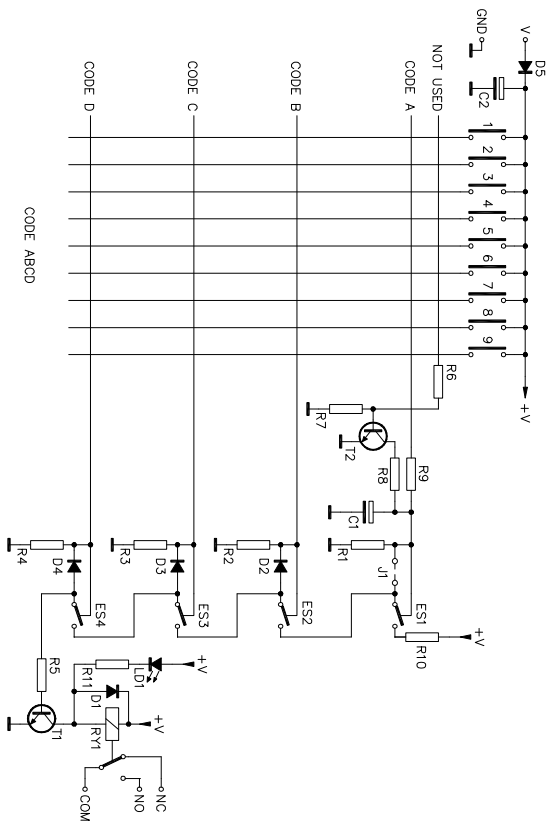

VELLEMAN Components NV
Legen Heirweg 33
9890 Gavere
Belgium Europe
<http://www.velleman.be>
<http://www.velleman-kit.com>

Modifications and typographical errors reserved
© Velleman Components nv.
H6400IP - 2001 - ED2