

HDC insert HDC HQ 7 MC

Weidmüller Interface GmbH & Co. KG
 Klingenbergstraße 16
 D-32758 Detmold
 Germany
 Fon: +49 5231 14-0
 Fax: +49 5231 14-292083
 www.weidmueller.com



The HQ series - big features in a compact design The electrical values speak for themselves. The standard HE crimp contacts can also be used here. The wire connection level is designed as a crimp contact. The established crimp connection has been used as a standard for decades. Crimp contacts are not delivered with the inserts. Pole count: **7 (+PE)**
 Rated current: **10 A**
 Rated voltage: **400 V**
 Nominal voltage acc. to UL/CSA: **600 V AC/DC**
 Crimp connection

General ordering data

Type	HDC HQ 7 MC
Order No.	1003190000
Version	HDC insert, Pin, 400 V, 10 A, No. of poles: 7, Crimp connection, Size: 1
GTIN (EAN)	4032248698189
Qty.	1 pc(s).

**HDC insert
HDC HQ 7 MC**

Weidmüller Interface GmbH & Co. KG
Klingenbergstraße 16
D-32758 Detmold
Germany
Fon: +49 5231 14-0
Fax: +49 5231 14-292083
www.weidmueller.com

Technical data
Dimensions and weights

Width	21 mm	Width (inches)	0.827 inch
Height	39.5 mm	Height (inches)	1.555 inch
Depth	21 mm	Depth (inches)	0.827 inch
Net weight	15.4 g		

Temperatures

Limit temperature	-40 °C ... 125 °C
-------------------	-------------------

Environmental Product Compliance

REACH SVHC	Lead 7439-92-1
------------	----------------

Dimensions

Height of plug	39.5 mm	Total length base	21 mm
----------------	---------	-------------------	-------

General data

Insulating material	PC glass-fibre reinforced (UL-listed and railway-certified)	Insulating material group	IIIa
Insulation strength	$10^{10} \Omega$	Material	Copper alloy
No. of poles	7	Plugging cycles, gold	≥ 500
Plugging cycles, silver	≥ 500	Pollution severity	3
Rated current (DIN EN 61984)	10 A	Rated impulse voltage (DIN EN 61984)	6 kV
Rated voltage (DIN EN 61984)	400 V	Rated voltage according to UL/CSA	600 V AC/DC
Series	HQ	Size	1
Surface finish	Silver passivated, gold	Type	Pin
UL 94 flammability rating	V-0	Volume resistance	$\leq 4m\Omega$

Connection data PE

Blade size, slotted (PE connection)	SD 0.6 x 3.5	Connection type PE	Screw connection
Fixing screw	M 3	Rated cross-section	2.5 mm ²
Stripping length PE connection	5 mm	Tightening torque, max. PE connection	0.55 Nm
Tightening torque, min. PE connection	0.5 Nm	Wire connection cross section, finely stranded, max.	2.5 mm ²
Wire connection cross-section, finely stranded with wire-end ferrules DIN 46228/4, max.	2.5 mm ²	Wire connection cross-section, finely stranded with wire-end ferrules DIN 46228/4, min.	0.14 mm ²
Wire connection cross-section, finely stranded, min.	0.14 mm ²	Wire cross section, AWG (PE), max.	AWG 14
Wire cross section, AWG (PE), min.	AWG 26		

HDC insert HDC HQ 7 MC

Weidmüller Interface GmbH & Co. KG
 Klingenbergstraße 16
 D-32758 Detmold
 Germany
 Fon: +49 5231 14-0
 Fax: +49 5231 14-292083
 www.weidmueller.com

Technical data

Version

Conductor cross-section, max.	2.5 mm ²	Conductor cross-section, min.	0.14 mm ²
Material	Copper alloy	Size	1
Stripping length, rated connection	8 mm	Surface finish	Silver passivated, gold
Type of connection	Crimp connection	Volume resistance	≤ 4mΩ
Wire connection cross section AWG, max.	AWG 14	Wire connection cross section AWG, min.	AWG 26
Wire connection cross section, finely stranded, max.	2.5 mm ²	Wire connection cross-section, finely stranded with wire-end ferrules DIN 46228/4, max.	2.5 mm ²
Wire connection cross-section, finely stranded with wire-end ferrules DIN 46228/4, min.	0.14 mm ²	Wire connection cross-section, finely stranded, min.	0.14 mm ²

Classifications

ETIM 3.0	EC001121	ETIM 4.0	EC001121
ETIM 5.0	EC001121	ETIM 6.0	EC000438
UNSPSC	30-21-18-01	eClass 5.1	27-14-34-19
eClass 6.2	27-14-34-19	eClass 7.1	27-44-02-05
eClass 8.1	27-44-02-05	eClass 9.0	27-44-02-05
eClass 9.1	27-44-02-05		

Approvals

Approvals



ROHS Conform

Downloads

Brochure/Catalogue	CAT 3 HDC 17/18 EN FL FIELDWIRING EN
Engineering Data	EPLAN, WSCAD
Engineering Data	STEP

**HDC insert
HDC HQ 7 MC**

Weidmüller Interface GmbH & Co. KG
Klingenbergstraße 16
D-32758 Detmold
Germany
Fon: +49 5231 14-0
Fax: +49 5231 14-292083
www.weidmueller.com

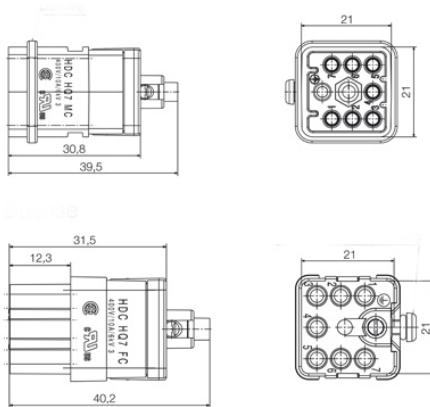
Drawings

Tightening torques and screwing tools

Screw size	Connector type	Dia. tightening torque in Nm	Recommended blade inserts and AF size for hexagon socket	
M 2.5	Signal contacts			
	S 6/6	0.5 - 0.55	SD 0.6 x 3.5 mm or PZ0	
	S 6/12	0.5 - 0.55	SD 0.6 x 3.5 mm or PZ0	
M 2.9 x 0.5	Fastening screws			
	HQ 4/2	0.8 (plastic) / 1.1 (metal)	SD 0.6 x 3.5 mm or PH0	
	HQ 8	0.8 (plastic) / 1.1 (metal)	SD 0.6 x 3.5 mm or PH0	
	HQ 17	0.8 (plastic) / 1.1 (metal)	SD 0.6 x 3.5 mm or PH0	
M 3	Contact screws			
	HA 3	0.5 - 0.55	SD 0.5 x 3.0 mm	
	HA 4	0.5 - 0.55	SD 0.5 x 3.0 mm	
	HA 10 bis HA 48	0.5 - 0.55	SD 0.6 x 3.5 mm or PH0	
	HE	0.5 - 0.55	SD 0.6 x 3.5 mm or PZ0	
	HVE	0.5 - 0.55	SD 0.6 x 3.5 mm or PZ0	
	Signal contacts:			
	S 4/2	0.5 - 0.55	SD 0.6 x 3.5 mm or PZ0	
	S 4/8	0.5 - 0.55	SD 0.6 x 3.5 mm or PZ0	
	PE connection via female contact			
	S 4	0.5 - 0.8	SD 0.6 x 3.5 mm	
	ConCept modular frame, metal	0.5 - 0.55	SD 0.6 x 3.5 mm	
	PE terminal			
	HQ 5	0.5 - 0.55	SD 0.6 x 3.5 or 0.8 x 4 mm	
	HQ 7	0.5 - 0.55	SD 0.6 x 3.5 or 0.8 x 4 mm	
	Fastening screws	0.5 - 0.55	SD 0.6 x 3.5 mm or PZ0	
	Guide pin	0.5 - 0.55	SD 0.6 x 3.5 mm or PZ0	
	Guide bush	0.5 - 0.55	SD 0.6 x 3.5 mm or PZ0	
	Coding pins	0.5 - 0.55	SD 0.6 x 3.5 mm or PZ0	
	M 4	Contact screws		
		HSB	1.2 - 1.5	SD 0.6 x 3.5 or 0.8 x 4 mm or PZ1
PE connection via male contact				
S 4		0.5 - 0.8	SD 0.6 x 3.5 mm	
ConCept modular frame, metal		1.2 - 1.5	SD 0.6 x 3.5 mm	
PE terminal				
HA		1.2 - 1.5	SD 0.6 x 3.5 or 0.8 x 4 mm or PH1	
HE		1.2 - 1.5	SD 0.6 x 3.5 or 0.8 x 4 mm or PH1	
HEE		1.2 - 1.5	SD 0.6 x 3.5 or 0.8 x 4 mm or PH1	
HVE		1.2 - 1.5	SD 0.6 x 3.5 or 0.8 x 4 mm or PH1	
HD		1.2 - 1.5	SD 0.6 x 3.5 or 0.8 x 4 mm or PZ1	
HDD		1.2 - 1.5	SD 0.6 x 3.5 or 0.8 x 4 mm or PZ1	
S 6/6 (for signal contacts)		1.2 - 1.5	0.8 x 4 mm or PZ1	
ConCept modular frame, plastic		1.2 - 1.5	0.8 x 4 mm or PZ1	
M 5		PE terminal		
	HSB	2 - 2.5	SD 1 x 5.5 mm or PZ2	
	S 4/0 (Screw connection)	2 - 2.5	SD 1.2 x 6.5 mm or PH2	
	S 4/0 (Axial screw connection)	2 - 2.5	SD 0.8 x 4 mm or PZ 2	
	S 4/2	2 - 2.5	SD 1.2 x 6.5 mm or PH2	
	S 4/8	2 - 2.5	SD 1.2 x 6.5 mm or PH2	
	S 6/12	2 - 2.5	SD 0.8 x 4 mm or PZ 2	
	S 6/36	2 - 2.5	SD 1.2 x 6.5 mm or PH2	
	S 8/24	2 - 2.5	SD 1.2 x 6.5 mm or PH2	
	S 12/2	2 - 2.5	SD 1.2 x 6.5 mm or PH2	
	M 6	Power contacts		
S 4/0 (Screw connection)		1.2 (1.5 mm ²) / 2 (2.5 mm ²) / 3 (4-16 mm ²)	SD 0.8 x 4 mm	
S 4/2		1.2 (1.5 mm ²) / 2 (2.5 mm ²) / 3 (4-16 mm ²)	SD 0.8 x 4 mm	
S 4/8		1.2 (1.5 mm ²) / 2 (2.5 mm ²) / 3 (4-16 mm ²)	SD 0.8 x 4 mm	
M 7 x 0.75	Power contacts			
	S 4	1.1 - 1.7	SW 2	
	S 6/6 (+ PE)	6 - 8	SW 4	
M 8 x 0.75	Power contacts			
	S 6/12	1.1 - 1.7	SW 2	
	S 8/0 (+ PE)	6 (10-16 mm ²) - 7 (25 mm ²)	SW 4	
M10 x 1	Power contacts			
	S 4/0 (Axial connection)	2 - 3	SW 3	

Increasing the tightening torque does not improve the contact resistance. The stated torque settings offer optimal mechanical, thermal and electrical conditions. Exceeding the recommended values may even damage the conductor and terminal.