



WACHENDORFF

Prozesstechnik GmbH & Co. KG

Controller URDR0001

User manual



Version 1.0



Summary

1	Safety instructions	5
1.1	General instructions.....	5
1.2	Intended Usage.....	5
1.3	Qualified personnel.....	6
1.4	Remaining hazards.....	6
1.5	CE Conformity.....	6
2	Model identification	7
3	Technical Data	7
3.1	General data	7
3.2	Hardware data	7
3.3	Software data.....	8
4	Dimensions and Installation.....	9
5	Electrical wirings	10
5.1	Wiring diagram.....	10
6	Display and Key Functions.....	16
6.1	Numeric Indicators (Display).....	16
6.2	Meaning of Status Lights (Led).....	16
6.3	Keys.....	17
7	Controller Functions.....	17
7.1	Modifying Main Setpoint and Alarm Setpoint Values	17
7.2	Auto-Tuning	18
7.3	Manual Tuning.....	18
7.4	Automatic Tuning.....	18
7.5	Soft-Start.....	18
7.6	Automatic / Manual Regulation for % Output Control.....	19
7.7	Pre-Programmed Cycle	20



7.8	Programming Modul.....		21
7.9	Loading default values.....		22
7.10	Latch on functions.....		23
7.11	Loop Break Alarm On Current Transformer.....		24
7.12	Digital Input Functions.....		25
7.13	Dual Action Heating-Cooling		26
8	Serial Communication.....		29
9	Configuration.....		35
9.1	Modify Configuration Parameters.....		35
10	Table of Configuration Parameters.....		36
11	Alarm Intervention Modes.....		54
12	Table of Anomaly Signals.....		59
13	Summary of Configuration parameters		59

Introduction

Dear valued Customer! Thank you for purchasing and using a product from our company. The compact universal controller URDR integrates in a single device all options for sensor reading and actuators command, beside extended supply range 24 to 230 Vac/Vdc. Thanks to 18 selectable sensors and outputs configurable as relay, SSR command, 4 to 20 mA and 0 to 10 Volt the user can reduce stock needs.

The series includes also a model with serial communication RS485 Modbus RTU and with a loading control function via the amperometric transformer. The possibility to repeat parametrization is simplified by the programming module with internal battery that do not require power supply for the controller. For getting the highest effort out of this unit, we kindly ask you to follow the below mentioned instructions:

Every person who is involved with the installation or usage of this unit, must read carefully and understand the installation manual and safety instructions!

1 Safety instructions

1.1 General instructions



To ensure the safe operation of this unit the instructions that appear in this manual must be strictly observed. In addition, when used all applicable legal and safety regulations for the respective application must be observed. The same applies correspondingly to the use of accessories.

1.2 Intended Usage

Units from the controller series UR are used for displaying and monitoring of process values. Any other use is regarded not in accordance with the intended usage. Units from the controller series UR are not meant to be used as sole safety means to prevent dangerous situations on machinery and installations. Machinery and installations must be so designed that fault conditions can not lead to harmful situations to operating personnel (e.g. by independent limit value switches, mechanical locking etc.).

1.3 Qualified personnel

Units from the controller series UR must only be operated in accordance with the technical specifications by qualified personnel. Personnel regarded qualified is familiar with the installation, assembly, putting into operation and operation of the units and possesses adequate professional qualification for the task.

1.4 Remaining hazards

Units from the controller series UR are state of the art and safe to operate. A risk of danger can occur when deployed and operated improperly by untrained personnel.

In this manual remaining hazards are marked by the following warning symbol:



This symbol indicates that non-observance of the safety guidelines may cause hazards to persons even serious injury or death and/or the possibility of property damage.

1.5 CE Conformity

The CE certificate is available at our company. We are pleased to send you a copy of it. Please feel free and contact us to get a copy.

2 Model identification

Power supply 24...230 Vac/Vdc +/- 15% 50/60Hz – 5,5VA

URDR0001 2 Relays 5A + 1 SSR/V/mA + RS485 +T.A.*

* Model with current transformer input for "Loop Break Alarm" function.

3 Technical Data

3.1 General data

Displays	4x0.40 inch displays 4x0.30 inch displays
Operating temperature	Temperature 0-45 °C Humidity 35..95 uR%
Sealing	IP65 front panel IP20 box and terminals
Material	PC ABS UL94VO self-extinguishing
Weight	165 g

3.2 Hardware data

	AN1 Configurable via software	
	Input Thermocouple type K, S, R, J. Automatic compensation of cold junction from from 0°C to 50°C.	Tolerance (25°C) +/-0.2 % ± 1 digit for thermocouple input, thermo resistance and V/mA.
Analogue input	Thermoresistance: PT100, PT500, PT1000, Ni100, PTC1K, NTC10K (β 3435K)	Cold junction accuracy 0.1°C/°C.
	Linear: 0-10V, 0-20 or 4-20mA, 0-40mV, amperometric transformer T.A. 50mA 1024 points	Impedance: 0-10 V: Ri>110KΩ 0-20 mA: Ri<5Ω 4-20 mA: Ri<5Ω 0-40 mV: Ri>1MΩ
	Potentiometers: 6 KΩ, 150 KΩ.	

Relay output	2 relays Configurable for command or alarm.	Contacts 5A/250V~Resistite loads
SSR/V/mA output	1 linear 0/4...20mA /SSR/0...10Volt Configurable as command or re-transmission of setpoint/process	Configurable: - SSR 12V 30mA - 0-10V (9500 points) - 0-20mA (7500 points) - 4-20mA (6000 points)

3.3 Software data

Regulation algorithms	ON - OFF with hysteresis. P, P.I., P.I.D., P.D. with proportional time.
Proportional band	0...9999 °C or °F
Integral time	0,0...999,9 sec. (0 excludes integral function)
Derivative time	0,0...999,9 sec. (0 excludes derivative function)
Controller functions	Manual or automatic Tuning, configurable alarms, protection of command and alarm setpoints, activation of functions via digital input, preset cycle with Start / Stop.

4 Dimensions and Installation

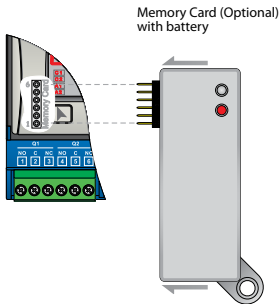
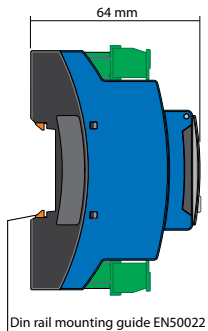
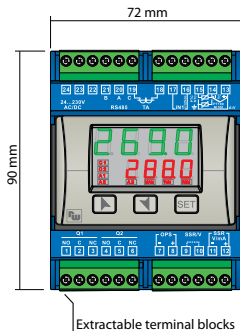

5 Electrical wirings



Although this controller has been designed to resist noises in an industrial environment, please notice the following safety guidelines:

- Separate control lines from the power wires.
- Avoid the proximity of remote control switches, electromagnetic meters, powerful engines.
- Avoid the proximity of power groups, especially those with phase control.

5.1 Wiring diagram

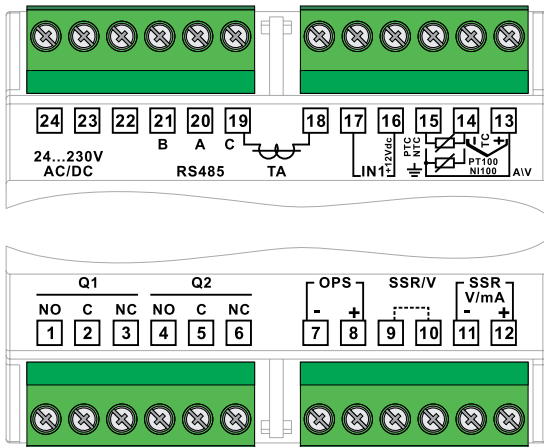

Power supply



Switching supply with extended range
24...230 Vac/dc $\pm 15\%$ 50/60Hz – 5,5VA
(galvanic isolated)

AN1 Analogue Input

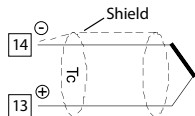

For thermocouples K, S, R, J.

- Comply with polarity.
- For possible extensions, use a compensated wire and terminals suitable for the thermocouples used (compensated).
- When shielded cable is used, it should be grounded at one side only.

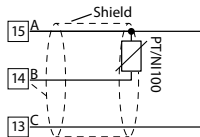

For thermoresistances PT100, NI100.

- For the three-wire connection use wires with the same section.
- For the two-wire connection short-circuit terminals 1 and 3.
- When shielded cable is used, it should be grounded at one side only.
- Select internal jumper JP3 as in the figure.

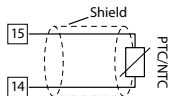

For thermoresistances NTC, PTC, PT500, PT1000
and potentiometers.

When shielded cable is used, it should be grounded at one side only to avoid ground loop currents.

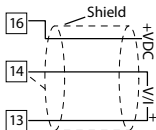

For linear signals V / mA.

- Comply with polarity.
- When shielded cable is used, it should be grounded at one side only.

Example of Connection for linear input Volt and mA

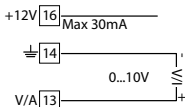

For signals 0....10 V.

Comply with polarity.

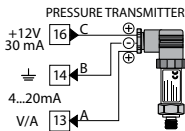

For signals 0/4....20 mA with **three-wire sensor**.

Comply with polarity:

- A= Sensor output
- B= Sensor ground
- C= Sensor power

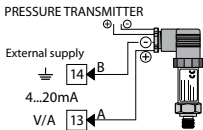

For signals 0/4....20 mA with **external power of sensor**.

Comply with polarity:

- A= Sensor output
- B= Sensor ground

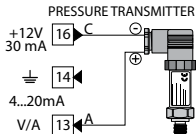

For signals 0/4...20 mA with **two-wire sensor**.

Comply with polarity:
 A= Sensor output
 C= Sensor power supply

Serial Input

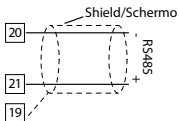

RS485 Modbus RTU communication.

- For networks with more than five instruments supply in low voltage, preferably Vdc.
- Shield must **not** be grounded.

Relay Q1 - Q2 Output

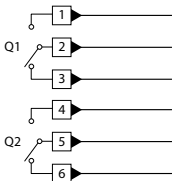

Capacity:

- 5 A / 250 V~ for resistive loads, 10^5 operations.
- 20/2 A, 250 Vac, $\cos\phi = 0.3$, 10^5 operations.

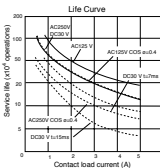

SSR output

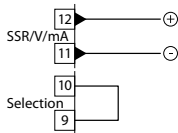

SSR command 12V/30mA
Short-circuit pins 9 and 10 as in the figure to use SSR output

mA / Volt output

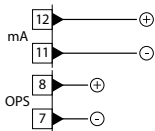

Pins 11-12: linear output in **mA** configurable using parameters as command (Parameter *c.OuE*) or retransmission of process or setpoint (Parameter *rEEr*).

Pins 7-8: optional external power supply for current loop (max 24Vdc).

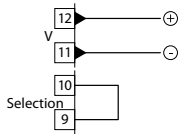

Linear output in Volt configurable using parameters as command (Parameter *c.OuE*) or retransmission of process or setpoint (Parameter *rEEr*).



Short-circuit pins 9 and 10 as in the figure to use linear output in Volt.

Current Transformer Input

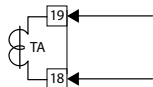

- Input 50mA for amperometric transformer
- Sampling time 80ms
- Configurable by parameters

Digital Input 1

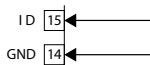

Combined use of digital input and T.A. input
Digital input according to parameter $dU_{T. i}$.



This combined use is possible only with sensors TC, 0...10V, 0/4...20mA, 0...40mV.

Digital Input 2

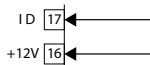

Use of digital input without T.A. input
Digital input according to parameter $dU_{T. i}$.

6 Display and Key Functions

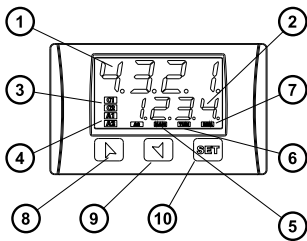



6.1 Numeric Indicators (Display)

- | | | |
|---|-------------|---|
| 1 | 1234 | Normally displays the process. During the configuration phase, it displays the parameter being inserted. |
| 2 | 1234 | Normally displays the setpoint. During the configuration phase, it displays the parameter value being inserted. |

6.2 Meaning of Status Lights (Led)

- | | | |
|---|-----------------|---|
| 3 | C1 C2 | ON when the output command is on.
C1 with relay/SSR/mA/Volt command or C1 (open) and C2 (close) for a motorised valve command. |
| 4 | A1 A2 A3 | ON when the corresponding alarm is on. |
| 5 | Man | ON when the "Manual" function is on. |
| 6 | tun | ON when the controller is running an "Autotune" cycle. |
| 7 | rem | ON when the controller communicates via serial port. |





6.3 Keys

- 8 
- Allows to increase the main setpoint.
 - During the configuration phase, allows to slide through parameters. Together with the **SET** key it modifies them.
 - Pressed after the **SET** key it allows to increase the alarm setpoint.
-
- 9 
- Allows to decrease the main setpoint.
 - During the configuration phase, allows to slide through parameters. Together with the **SET** key it modifies them.
 - Pressed after the **SET** key it allows to decrease the alarm setpoint.
-
- 10 **SET**
- Allows to display the alarm setpoint and runs the autotuning function.
 - Allows to vary the configuration parameters.
-

7 Controller Functions

7.1 Modifying Main Setpoint and Alarm Setpoint Values

The setpoint value can be changed by keyboard as follows:

	Press	Display	Do
1	 or 	Value on display 2 changes.	Increases or decreases the main setpoint.
2	SET	Visualize alarm setpoint on display 1 value being inserted.	
3	 or 	Value on display 2 changes.	Increases or decreases the alarm setpoint value.

7.2 Auto-Tuning

Tuning procedure calculates the controller parameters and can be manual or automatic according to selection on parameter 57 ($\epsilon_{\text{UN}}E$).

7.3 Manual Tuning

Manual procedure allows the user greater flexibility to decide when to update P.I.D. algorithm work parameters. The procedure can be activated in two ways:

- **Running Tuning by keyboard:**

Press **SET** key until display 1 shows the writing $\epsilon_{\text{UN}}E$ with display 2 showing αFF , press **▲**, display 2 shows αn .

TUN led switches on and the procedure begins.

- **Running Tuning by digital input:**

Select $\epsilon_{\text{UN}}E$ on parameter 61 $d\bar{C}\bar{L}.i$. At first activation of digital input (commutation on front panel) **TUN** led switches on and at second activation switches off.

7.4 Automatic Tuning

Automatic tuning activates when the controller is switched on or when the setpoint is modified to a value over 35%.

To avoid an overshoot, the threshold where the controller calculates new P.I.D. parameters is determined by the setpoint value minus the "Set Deviation Tune" (see parameter 58 $S.d.\epsilon_{\text{U}}$).

To exit Tuning and keep P.I.D. values unchanged, press **SET** key until display 1 shows the writing $\epsilon_{\text{UN}}E$ and display 2 shows αn . Press **▼**, display 2 shows αFF . **TUN** led switches off and procedure finishes.

7.5 Soft-Start

To reach the setpoint the controller can follow a gradient expressed in units (example: Degree/Hours).

Enter the gradient on parameter 62 $\bar{C}r\bar{A}d$. with chosen Units/Hours; only on subsequent activation the controller uses Soft-Start function.

If parameter 59 $P.P.$ is set on $C.O.N.T.$ and parameter 63 $P.A.T.$ is different from 0, after switch-on and elapsing of the time set on parameter 63, setpoint does not follow the gradient anymore, but it reaches final setpoint with maximum power. Autotuning does not work when Soft-Start is activated: otherwise if parameter 63 $P.A.T.$ is different from 0 and parameter 57 $T.U.N.E$ is set on $A.U.T.O.$, Autotuning starts when Soft-Start time is finished.

If parameter 57 $T.U.N.E$ is set on $M.A.N.$, the Autotuning can be started only when Soft-Start finishes.

7.6 Automatic / Manual Regulation for % Output Control

This function allows to select automatic functioning or manual command of the output percentage.

With parameter 60 $A.U.P.A.$, can select two methods.

1 First selection ($E.N.$)

Pressing **SET** key display 1 shows $P.---$, while display 2 shows $A.U.T.O.$

Pressing **▲** key display shows $M.A.N.$; it is now possible to change the output percentage using **▲** and **▼**. To return to automatic mode, using the same procedure, select $A.U.T.O.$ on display 2: led MAN switches off and functioning returns to automatic mode.

2 Second selection ($E.N.S.T.$)

enables the same functioning, but with two important variants:

- If there is a temporary power failure or after switch-off, the manual functioning as well as the previous output percentage value will be maintained at restarting.
- If the sensor breaks during automatic functioning, the controller moves to manual mode while maintaining the output percentage command unchanged as generated by the P.I.D. immediately before breakage.

7.7 Pre-Programmed Cycle

The pre-programmed cycle function activates by setting $P_r.c4$ or $P_c.55$ on parameter 59 $\alpha P. \Pi \alpha$.

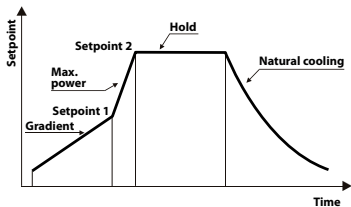

First selection ($P_r.c4$):

the controller reaches setpoint1 basing on the gradient set on parameter 62 $\zeta rAd.$, then it reaches maximum power up to setpoint 2. When the process reaches maximum power, this setpoint is maintained for the time set on parameter 63 $\Pi A. \epsilon \iota$. On expiry, the command output is disabled and controller displays $St \alpha P$.

Cycle starts at each activation of the controller, or via digital input if it is enabled for this type of functioning (see parameter 61 $dGt. \iota$).

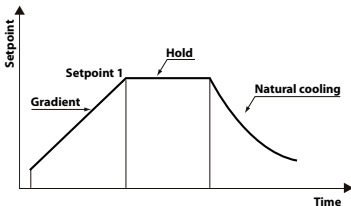

Second selection ($P_r.c4$):

start-up is decided only on activation of the digital input, according to the setting of parameter 61 $dGt. \iota$. On start-up, controller reaches setpoint 1 following gradient set in parameter 62 $\zeta rAd.$

When the process reaches this gradient, it is maintained for the time set on parameter 63 $\Pi A. \epsilon \iota$. On expiry, command output is disabled and the controller displays $St \alpha P$.

7.8 Programming Module (optional)



Parameters and setpoint values can be duplicated from one controller to another using the Programming Module.

2 modes are available:

- With the controller connected to the power supply.

Insert memory card **when the controller is off**.

On activation display 1 shows \overline{MEM} and display 2 shows --- (only if the correct values are saved in the Programming Module). By pressing  key display 2

shows \overline{LOAD} , then confirm using  key.

Controller loads the new value and restarts.

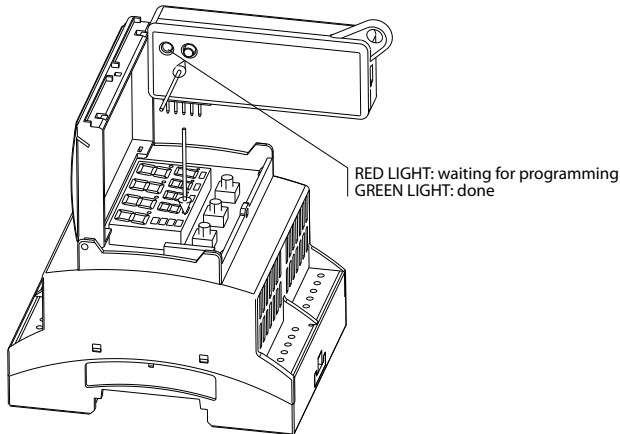

- With the controller not connected to power supply. The memory card is equipped with an internal battery with an autonomy of about 1000 uses (2032 button battery, replaceable). Insert the memory card and press the programming buttons. When writing the parameters, led turns red and on completing the procedure it changes to green. It is possible to repeat the procedure without any particular attention.







Updating Programming Module

To update the memory card values, follow the procedure described on first mode, setting display 2 to - - - - so as not to load the parameters on controller¹.

Enter configuration and change at least one parameter. Exit configuration. Changes are stored automatically.

7.9 Loading default values

This procedure allows to restore factory settings of the instrument.

	Press	Display	Do
1	 for 3 seconds	Display 1 visualizes 0.000 with 1st digit blinking, while display 2 shows PASS.	
2	 	Change blinking digit and move to the next one with  .	Enter password: 9999.
3	 to confirm	Device loads default settings.	Turn off and restart the instrument.

¹ If on activation the controller does not display $\Pi E \Pi \square$ it means no data have been saved on the Programming module, but it is possible to update values.

7.10 Latch on functions





For use with input $P_{0L.1}$ (potentiometer 6 K Ω) and $P_{0L.2}$ (potentiometer 150 K Ω) and with linear input (0...10 V, 0...40 mV, 0/4...20 mA), it is possible to associate start value of the scale (parameter 6 $L_{0L.1}$) to the minimum position of the sensor and value of end scale (parameter 7 $u_{PL.1}$) to the maximum position of the sensor (parameter 8 L_{ALC} , configured as S_{Ed}).

It is also possible to fix the point in which the controller will display 0 (however keeping the scale range between $L_{0L.1}$ and $u_{PL.1}$) using the "virtual zero" option by setting u_{DSE} or u_{DIN} in parameter 8 L_{ALC} .

If you set u_{DIN} , the virtual zero will reset after each activation of the tool; if you set u_{DSE} , the virtual zero remains fixed once tuned.

To enable the LATCH ON function select chosen configuration for parameter L_{ALC}^2 .

For the calibration procedure refer to the following table:

	Press	Display	Do
1	  simultaneously	Exit parameters configuration. Display 2 shows the writing L_{ALC} .	Place the sensor on minimum operating value (associated with $L_{0L.1}$).
2		Set the value on minimum. Display shows L_{0L} .	Place the sensor on maximum operating value (associated with $u_{PL.1}$).
3		Set the value to maximum. The display shows H_{iGH} .	To exit standard procedure press SET . For "virtual zero" settings place the sensor on the zero point.

² The tuning procedure starts by exiting the configuration after changing the parameter.

Press**Display****Do**

4

SET

Set the virtual zero value. Display shows *u.i.r.t.*. **NB:** For selection of *u.i.r.t.*, the procedure in point 4 should be followed on each re-activation.

To exit procedure press

SET.

7.11 Loop Break Alarm On Current Transformer

This function allows to measure load current and to manage an alarm during malfunctioning (with power in short circuit or always off).

The current transformer connected to terminals 15 and 16 must be 50 mA (sampling time 80 ms).

- Set end scale value of the current transformer in Amperes on parameter 47 *L.R.*
- Set the intervention threshold of the Loop Break Alarm in Amperes on parameter 48 *L.b.R.t.*
- Set the intervention delay time of the Loop Break Alarm on parameter 49 *L.b.R.d.*
- It is possible to associate the alarm with a relay by setting the parameter *RL. 1* and *RL. 2* as *L.b.R.*

If a remote control switch or SSR remains closed, controller signals the fault by showing *L.b.R.c.* on display 2 (alternatively with a command setpoint).

If the power stage remains open, or the load current is lower than the value set on $L.b.A.t.$, controller shows $L.b.A.o.$ on display. It is possible to display the current absorbed during the closure phase of the power stage.

	Press	Display	Do
1	SET	This key enables to scroll on display 2 the output percentage, auto / man selection, setpoint and alarms.	Press SET until the writing $A.t.t.A.$ appears on display 1 and display 2 shows the current in amperes ($t.A. >0$). The value is also maintained when no current circulates on the load.

Setting on parameter 48 $L.b.A.t.$ the value 0 it is possible to visualize the current absorbed without generating the Loop Break Alarm.

7.12 Digital Input Functions

On URDR model, digital input can be enabled by using parameters 59 $o.P.o.$ and 61 $dGt. i.$

- **Parameter 59 $o.P.o.$**

NB: When using this settings, parameter 61 $dGt. i.$ is ignored.

$2t.S.:$ Switch two thresholds setpoint: with open contact URDR regulates on SET1; with closed contact regulates on SET2;

$2t.S. i.:$ Switch two thresholds setpoint: setpoint selection is done by an impulse on digital input;

$3t.S. i.:$ Switch three thresholds setpoint by an impulse on digital input;

$4t.S. i.:$ Switch four thresholds setpoint by an impulse on digital input;

$t.r.E5.:$ Customized function;

$P.c.S.S.:$ Pre-programmed cycle (see paragraph 7.7).

Setpoints values can be modified any time pressing **SET** key.

- **Parameter 61** $d\bar{u}t. i.$

NB: Settings on this parameter are available only if $conE.$ or $Pr.cY.$ are selected on parameter 59 $\square P.\Pi\sigma.$

$St.St.:$ Start / Stop; operating on digital input the controller switches alternatively from start to stop;

$rn.n.\sigma.:$ Run N.O. Controller is in start only with closed input;

$rn.n.c.:$ Run N.C. Controller is in start only with open input;

$L.c.n.\sigma.:$ With closed input allows to lock the reading of sensors;

$L.c.n.c.:$ With open input allows to lock the reading of sensors;

$tunE:$ Enables / disables Tuning function if parameter 57 $tunE$ is selected as $\Pi Rn.;$

$A.\Pi A. i.:$ If parameter 60 $Au.\Pi A.$ is selected as $En.$ or $En.St.$ controller switch from automatic to manual functioning;

$A.\Pi A. c.:$ If parameter 60 $Au.\Pi A.$ is selected as $En.$ or $En.St.$ URDR works in automatic mode if input is open or in manual mode if input is closed.

7.13 Dual Action Heating-Cooling

URDR is suitable also for systems requiring a combined heating-cooling action. Command output must be configured as Heating P.I.D. ($A_{ct}.t. = HEAt$ and with a $P.b.$ greater than 0), and one of the alarms ($AL. 1, AL. 2$ or $AL. 3$) must be configured as $conL.$

Command output must be connected to the actuator responsible for heat, while the alarm will control cooling action.

Parameters to configure for the Heating P.I.D. are:

$A_{ct}.t. = HEAt$ Command output type (Heating);

$P.b.:$ Heating proportional band;

$t. i.:$ Integral time heating and cooling;

$t. d.:$ Derivative time heating and cooling;

$t. c.:$ Heating time cycle.

Parameters to configure for the Cooling P.I.D. are the following (ex: action associated to alarm 1):

$P.L.1 = \text{cool}$ Alarm 1 selection (Cooling);

$P.b.M.$: Proportional band multiplier;

$o.v.d.b.$: Overlapping / Dead band;

$c.o.t.c.$: Cooling time cycle.

Parameter $P.b.M.$ (that ranges from 1.00 to 5.00) determines the proportional band of cooling basing on the formula:

Cooling proportional band = $P.b. \times P.b.M.$

This gives a proportional band for cooling which will be the same as heating band if $P.b.M. = 1.00$, or 5 times greater if $P.b.M. = 5.00$.

Integral and derivative time are the same for both actions.

Parameter $o.v.d.b.$ determines the percentage overlapping between the two actions. For systems in which the heating and cooling output must never be simultaneously active a dead band ($o.v.d.b. \leq 0$) can be configured, and vice versa an overlapping ($o.v.d.b. > 0$).

The following figure shows an example of dual action P.I.D. (heating-cooling) with $t.i. = 0$ and $t.d. = 0$.

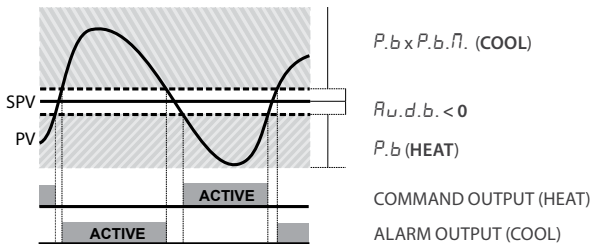

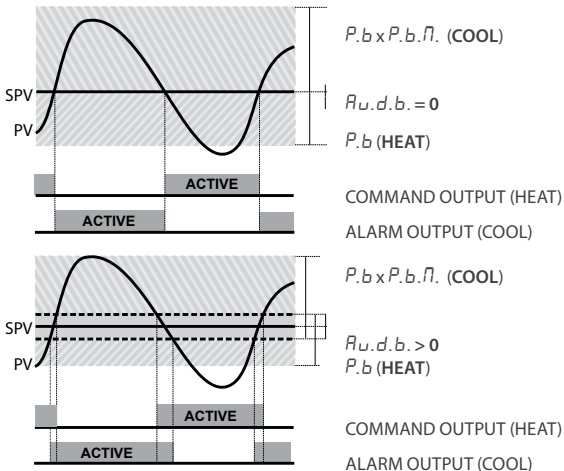

Parameter $co.t.c.$ has the same meaning as the heating time cycle $t.c.$
 Parameter $coo.F.$ (cooling fluid) pre-selects the proportional band multiplier $P.b.\Pi.$ and the cooling P.I.D. time cycle $co.t.c.$ basing on the type of cooling fluid:

$coo.F.$	Cooling fluid type	$P.b.\Pi.$	$co.t.c.$
Air	Air	1.00	10
oil	Oil	1.25	4
H ₂ O	Water	2.50	2

Once selected, parameter $coo.F.$, parameters $P.b.\Pi.$, $oud.b.$ and $co.t.c.$ can however be changed.

8 Serial Communication

URDR0001, equipped with RS485, can receive and broadcast data via serial communication using MODBUS RTU protocol. The device can only be configured as a Slave. This function enables the control of multiple controllers connected to a supervisory system (SCADA). Each controller responds to a master query only if the query contains the same address as that in the parameter *SL.Ad*.

The permitted addresses range from 1 to 254 and there must not be controllers with the same address on the same line. Address 255 can be used by the master to communicate with all the connected equipment (broadcast mode), while with 0 all the devices receive the command, but no response is expected.

URDR can introduce a delay (in milliseconds) in the response to the master request. This delay must be set on parameter *72 SE.dE*. Each parameter change is saved by the controller on EEPROM memory (100000 writing cycles), while the setpoints are saved with a delay of ten seconds after the last change.

NB: changes made to Words that are different from those reported in the following table can lead to malfunction.

Modbus RTU protocol features

	Selection on parameter <i>70 bd.rE</i> :	
Baud-rate	<i>4.8</i> † 4.800 bit/Sec.	<i>28.8</i> † 28.800 bit/Sec.
	<i>9.6</i> † 9.600 bit/Sec.	<i>38.4</i> † 38.400 bit/Sec.
	<i>19.2</i> † 19.200 bit/Sec.	<i>57.6</i> † 57.600 bit/Sec.
Format	8, N, 1 (8 bit, no parity, 1 stop)	
Supported functions	WORD READING (max 20 word) (0x03, 0x04)	
	SINGLE WORD WRITING (0x06)	
	MULTIPLE WORDS WRITING (max 20 word) (0x10)	

Looking at the table here below it is possible to find all available addresses and functions:

RO	Read Only	R/W	Read / Write	WO	Write Only
----	-----------	-----	--------------	----	------------



Modbus Address	Description	Read Only	Reset value
0	Device type	RO	EEPROM
1	Software version	RO	EEPROM
5	Slave address	RO	EEPROM
6	Boot version	RO	EEPROM
50	Automatic addressing	WO	-
51	System code comparison	WO	-
500	Loading default values (write 9999)	R/W	0
510	Setpoints storing time in eeprom (0-60 s)	R/W	10
999	Process subjected to the visualization filter	RO	-
1000	Process (degrees.tenths for temperature sensors; digits for linear sensors)	RO	-
1001	Setpoint 1	R/W	EEPROM
1002	Setpoint 2	R/W	EEPROM
1003	Setpoint 3	R/W	EEPROM
1004	Setpoint 4	R/W	EEPROM
1005	Alarm 1	R/W	EEPROM
1006	Alarm 2	R/W	EEPROM
1008	Setpoint gradient	RO	EEPROM
	Relay status (0 = Off, 1 = On):		
	Bit 0 = Relay Q1		
1009	Bit 1 = Relay Q2	RO	0
	Bit 2 = Reserved		
	Bit 3 = SSR		
1010	Heating output percentage (0-10000)	RO	0
1011	Cooling output percentage (0-10000)	RO	0
	Alarms status (0 = None, 1 = Active)		
1012	Bit 0 = Alarm 1 Bit 1 = Alarm 2	RO	0
	Manual reset: write 0 to reset all alarms.		
1013	In reading (0 = Not resettable, 1 = Resettable)	WO	0
	Bit 0 = Alarm 1 Bit 1 = Alarm 2		

Modbus Address	Description	Read Only	Reset value
1014	Error flags	RO	0
	Bit 0 = Eeprom writing error		
	Bit 1 = Eeprom reading error		
	Bit 2 = Cold junction error		
	Bit 3 = Process error (sensor)		
	Bit 4 = Generic error		
	Bit 5 = Hardware error		
	Bit 6 = L.B.A.O. error		
	Bit 7 = L.B.A.C. error		
Bit 8 = Missing calibration data error			
1015	Cold junction temperature (degrees.tenths)	RO	-
1016	Start / Stop	R/W	0
	0 = Controller in STOP 1 = Controller in START		
1017	Lock conversion ON / OFF	R/W	0
	0 = Lock conversion off 1 = Lock conversion on		
1018	Tuning ON / OFF	R/W	0
	0 = Tuning off 1 = Tuning on		
1019	Automatic / manual selection	R/W	0
	0 = Automatic 1 = Manual		
1020	T.A. current ON (Ampere with tenths)	RO	-
1021	T.A. current OFF (Ampere with tenths)	RO	
1022	OFF LINE* time (milliseconds)	R/W	

* If value is 0, the control is disabled. If different from 0, it is the max. time which can elapse between two pollings before the controller goes off-line. If it goes off-line, the controller returns to Stop mode, the control output is disabled but the alarms are active.

Modbus Address	Description	Read Only	Reset value
1023	Instant Current (Ampere)	R/W	0
1024	Digital Input State	R/W	0
	Synchronized Tuning for multizone system		
	0 = Tuning OFF (Normal operating of the regulator)		
	1 = Output command OFF		
1025	2 = Output command ON	R/W	0
	3 = Start Tuning		
	4 = End Tuning and output command OFF		
	(Write 0 for normal operating)		
1099	Process subjected to the visualization filter and decimal point selection	RO	
1100	Process with decimal point selection	RO	
1101	Setpoint 1 with decimal point selection	R/W	EEPROM
1102	Setpoint 2 with decimal point selection	R/W	EEPROM
1103	Setpoint 3 with decimal point selection	R/W	EEPROM
1104	Setpoint 4 with decimal point selection	R/W	EEPROM
1105	Alarm 1 with decimal point selection	R/W	EEPROM
1106	Alarm 2 with decimal point selection	R/W	EEPROM
1108	Gradient Setpoint with decimal point selection	RO	EEPROM
1109	Percentage heating output (0-1000)	R/W	0
1110	Percentage heating output (0-100)	RO	0
1111	Percentage cooling output (0-1000)	RO	0
1112	Percentage cooling output (0-100)	RO	0
2001	Parameter 1	R/W	EEPROM
2002	Parameter 2	R/W	EEPROM
2072	Parameter 72	R/W	EEPROM
3000	Disabling serial control of machine**	RO	0

** By writing 1 on this word, the effects of the writing are cancelled on all the Modbus addresses from 3001 to 3022. Control therefore returns to the controller.

Modbus Address	Description	Read Only	Reset value
3001	First word display 1 (ascii)	R/W	0
3002	Second word display 1 (ascii)	R/W	0
3003	Third word display 1 (ascii)	R/W	0
3004	Fourth word display 1 (ascii)	R/W	0
3005	Fifth word display 1 (ascii)	R/W	0
3006	Sixth word display 1 (ascii)	R/W	0
3007	Seventh word display 1 (ascii)	R/W	0
3008	Eighth word display 1 (ascii)	R/W	0
3009	First word display 2 (ascii)	R/W	0
3010	Second word display 2 (ascii)	R/W	0
3011	Third word display 2 (ascii)	R/W	0
3012	Fourth word display 2 (ascii)	R/W	0
3013	Fifth word display 2 (ascii)	R/W	0
3014	Sixth word display 2 (ascii)	R/W	0
3015	Seventh word display 2 (ascii)	R/W	0
3016	Eight word display 2 (ascii)	R/W	0
	Word LED		
	Bit 0 = LED C1		
	Bit 1 = LED C2		
	Bit 2 = LED A1 Bit 3 = LED A2		
3017	Bit 4 = LED A3	R/W	0
	Bit 5 = LED MAN		
	Bit 6 = LED TUN		
	Bit 7 = LED REM		
	Word keys		
	(write 1 to command keys)		
3018	Bit 0 = 	R/W	0
	Bit 1 = 		
	Bit 2 = 		













Modbus Address	Description	Read Only	Reset value
3019	Word serial relay Bit 0 = Relay Q1 Bit 1 = Relay Q2	R/W	0
3020	Word SSR serial (0 = Off, 1 = On)	R/W	0
3021	Word output 0...10 V serial (0...10000)	R/W	0
3022	Word output 4...20 mA serial (0...10000)	R/W	0
3023	Relay state in case of off-line (only if controlled by serial) Bit 0 = Relay Q1 Bit 1 = Relay Q2	R/W	0
3024	Output state SSR / 0...10 V / 4...20 mA in case of off-line (only if controlled by serial) (0...10000)	R/W	0
3025	Serial process. Setting parameter 54 it is possible to make averages on the remote process	R/W	0
4001	Parameter 1***	R/W	EEPROM
4002	Parameter 2***	R/W	EEPROM
4072	Parameter 72***	R/W	EEPROM

*** Parameteränderungen in seriellen Adressen 4001 und 4072 werden erst 10 Sekunden nach der letzten Änderung im EEPROM gespeichert.

9 Configuration

9.1 Modify Configuration Parameters

For configuration parameters see paragraph 10.

	Press	Display	Do
1	 for 3 seconds	Display 1 shows <i>0.000</i> with the 1st digit flashing, while display 2 shows <i>PASS.</i>	
2	 or 	Changes flashing digit and move to the next one using  key.	Enter password: <i>1234.</i>
3	 to confirm	Display 1 shows the first parameter and display 2 shows the value.	
4	 or 	Slide up / down through parameters.	
5	  or 	Increase or decrease di- played value by pressing  and an arrow key.	Enter new data which will be saved on releasing the keys. To change another parameter return to point 4.
6	  simultaneously	End of configuration parameter change. The controller exits from programming.	

10 Table of Configuration Parameters

The following table includes all parameters. Some of them will not be visible on the models which are not provided with relevant Hardware data.

1 *C.out* Command Output



Command output type selection.

c.o1 **Default** (necessary for using process and setpoint re-transmission function with Volt / mA output)

c.o2

c.SSr

c.vAL.

c.4.20

c.0.20

c.0.10

URDR0001

	COMMAND	ALARM 1	ALARM 2
<i>c.o1</i>	Q1	Q2	SSR
<i>c.o2</i>	Q2	Q1	SSR
<i>c.SSr</i>	SSR	Q1	Q2
<i>c.vAL.</i>	Q1 (opens) Q2 (closes)	SSR	-
<i>c.4.20</i>	4 ... 20 mA	Q1	Q2
<i>c.0.20</i>	0 ... 20 mA	Q1	Q2
<i>c.0.10</i>	0 ... 10 mV	Q1	Q2

2 *SEn*. **Sensor**



Analogue input configuration/sensor selection

<i>t.c.t</i>	Tc-K (Default)	-260 °C ... 1360 °C
<i>t.c.S</i>	Tc-S	-40 °C ... 1760 °C
<i>t.c.r</i>	Tc-R	-40 °C ... 1760 °C
<i>t.c.J</i>	Tc-J	-200 °C ... 1200 °C
<i>Pt</i>	Pt100	-200 °C ... 600 °C
<i>Pt1</i>	Pt100	-200 °C ... 140 °C
<i>n i</i>	NI100	-60 °C ... 180 °C
<i>n t c</i>	NTC10K	-40 °C ... 125 °C
<i>P t c</i>	PTC1K	-50 °C ... 150 °C
<i>P t 5</i>	Pt500	-100 °C ... 600 °C
<i>P t 1 t</i>	Pt1000	-100 °C ... 600 °C
<i>0.10</i>	0 ... 10 Volt	
<i>0.20</i>	0 ... 20 mA	
<i>4.20</i>	4 ... 20 mA	
<i>0.40</i>	0 ... 40 mVolt	
<i>P o t . 1</i>	Potentiometer max 6 Kohm (See paragraph 7.10)	
<i>P o t . 2</i>	Potentiometer max 150 Kohm (See paragraph 7.10)	
<i>t . A .</i>	50 mA secondary Current transformer	

3 *d.P.* **Decimal Point**

Select type of visualized decimal point

<i>0</i>	Default
<i>0.0</i>	1 Decimal
<i>0.00</i>	2 Decimal
<i>0.000</i>	3 Decimal

4 *Lo.L.S.* Lower Limit Setpoint



Lower limit selectable for setpoint

-999...+9999 [digit³] (degrees.tenths for temperature sensors),
Default: 0.

5 *uP.L.S.* Upper Limit Setpoint



Upper limit selectable for setpoint

-999...+9999 [digit³] (degrees.tenths for temperature sensors),
Default: 1750.

6 *Lo.L.i* Lower Linear Input



Range AN1 lower limit only for linear. Example: with input 4...20 mA this parameter takes value associated to 4 mA

-999 bis +9999 [digit³], Default: 0.

7 *uP.L.i.* Upper Linear Input



Range AN1 upper limit only for linear. Example: with input 4...20 mA this parameter takes value associated to 20 mA

-999 bis +9999 [digit³], Default: 1000.

8 *LA.t.c.* Latch On Function

Automatic setting of limits for linear inputs and potentiometers (see paragraph 7.10)

dis. Disabled (Default)

Std. Standard

u.0St. Virtual zero stored

u.0in Virtual zero initialized

9 *o.cAL.* Offset Calibration

Value added / subtracted to process visualization (usually correcting the value of environment temperature)

-999...+1000 [digit³] for linear sensors and potentiometers.

-200.0...+100.0 (degrees.tenths for temperature sensors),

Default 0.0.

10 *G.cAL.* Gain Calibration

Percentage value that is multiplied for the process value (allows to calibrated the working point)

-99.9%...+100.0% (Default = 0.0)

11 *Act.t.* Action type

Regulation type

HEAt Heating (N.O.) (Default)

cooL Cooling (N.C.)

H.o.o.S. Lock command above SPV. Example: command output disabled when reaching setpoint, also with P.I.D. value different from 0

12 *c. rE.* Command Reset

Type of reset for state of command contact (always automatic in P.I.D. functioning)

ArE. Automatic reset (Default)

MrE. Manual reset

MrE.S. Manual reset stored (keeps relay status also after an eventual power failure)

13 *c. S.E.* **Command State Error**

State of contact for command output in case of error

c.o. Open contact (Default)

c.c. Closed contact

14 *c. Ld.* **Command Led**

State of the OUT1 led corresponding to the relevant contact

c.o. ON with open contact

c.c. ON with closed contact (Default)

15 *c. H4.* **Command Hysteresis**

Hysteresis in ON/OFF or dead band in P.I.D.

-999...+999 [digit3] (degrees.tenths for temperature sensors), Default 0.0.

16 *c. dE.* **Command Delay**

Command delay (only in ON / OFF functioning). In case of servo valve it also works in P.I.D. and represents the delay between opening and closure of the two contacts

-180...+180 seconds (tenths of second in case of servo valve).

Negative: delay in switching off phase.

Positive: delay in activation phase. **Default:** 0.

17 *c. S.P.* **Command Setpoint Protection**

Allows or not to modify the command setpoint value

FrEE Modification allowed (Default)

Loct Protected

18 *P.b.* Proportional Band



Proportional band Process inertia in units (ex: if temperature is in °C)
0 ON / OFF *t. r.* if equal to 0 (Default)
1-9999 [digit³] (degrees.tenths for temperature sensors)

19 *t. r.* Integral Time

Process inertia in seconds
0.0-999.9 seconds (0 = integral disabled), Default: 0.

20 *t. d.* Derivative Time

Normally ¼ of integral time
0.0-999.9 seconds (0 = derivative disabled), Default: 0.

21 *t. c.* Cycle Time

Cycle time (for P.I.D. on remote control switch 10 / 15 sec., for P.I.D. on SSR 1 sec.) or servo time (value declared by servo-motor manufacturer)
1-300 seconds, Default: 10.

22 *o.PoL.* Output Power Limit

Selects max value for command output percentage. 0-100%, Default: 100%.

³ Display of decimal point depends on setting of parameter *SEn.* and parameter *d.P.*

Alarm 1 selection. Alarm intervention is related to AL1 (See paragraph 11)

d.S. Disabled (Default)

A.AL. Absolute alarm, referring to process

b.AL. Band alarm

H.d.AL. Upper deviation alarm

L.d.AL. Lower deviation alarm

A.c.AL. Absolute alarm, referring to command setpoint

St.AL. Status alarm (active in Run / Start)

cool Cooling action

L.b.A. Status alarm "load control" (Loop Break Alarm). Example: status of contactors / SSR or heating elements

24 AL.5.o. Alarm 1 State Output

Alarm 1 output contact and intervention type

n.o. S. (N.O. start) Normally open, active at start

n.c. S. (N.C. start) Normally closed, active at start

n.o. t. (N.O. threshold) Normally open, active on reaching alarm⁴

n.c. t. (N.C. threshold) Normally closed on reaching alarm⁴

⁴ On activation, the output is inhibited if the controller is in alarm mode. Activates only if alarm condition reappears, after that it was restored.

25 *A1.rE.* Alarm 1 Reset

Alarm 1 contact reset type

ArE. Automatic reset (Default)

MrE. Manual reset **SET**

MrE.S. Manual reset stored. (keeps relay status also after an eventual power failure)

26 *A1.S.E.* Alarm 1 State Reset

State of contact for alarm 1 output in case of error

c.o. Open contact (Default)

c.c. Closed contact

27 *A1.Ld.* Alarm 1 Led

Defines the state of OUT2 led corresponding to the relative contact

c.o. ON with open contact

c.c. ON with closed contact (Default)

28 *A1.HY.* Alarm 1 Hysteresis

-999...+999 [digit^s] (degrees.tenths for temperature sensors), **Default:** 0.0.

29 *A1.dE.* Alarm 1 Delay

-180...+180 seconds. **Negative:** delay in alarm output phase.

Positive: delay in alarm entry phase. **Default:** 0.

⁵ *Display of decimal point depends on setting of parameter **SEn.** and parameter **d.P.***

30 *A.1.S.P.* Alarm 1 Setpoint Protection

Alarm 1 set protection. Does not allow user to modify setpoint

FrEE Modification allowed (Default)

Loct Protected

HiDE Protected and not visualized

31 *AL. 2* Alarm 2

Alarm 2 selection. Alarm intervention is related to AL2. (See paragraph 11)

diS. Disabled (Default)

A. AL. Absolute alarm, referring to process

b. AL. Band alarm

H.d.AL. Upper deviation alarm

L.d.AL. Lower deviation alarm

A.c.AL. Absolute alarm, referring to command setpoint

St.AL. Status alarm (active in Run / Start)

cool Cooling action

L.b.A. Status alarm "load control" (Loop Break Alarm). Example: status of contactors / SSR or heating elements

32 *A.2.S.o.* Alarm 2 State Output

Alarm 2 output contact and intervention type

n.o. S (N.O. start) Normally open, active at start (Default)

n.c. S (N.C. start) Normally closed, active at start

n.o. t (N.O. threshold) Normally open, active on reaching alarm⁶

n.c. t (N.C. threshold) Normally closed, active on reaching alarm⁶

⁶ On activation, the output is inhibited if the controller is in alarm mode. Activates only if alarm condition reappears, after that it was restored.

33 *A2.rE.* Alarm 2 Reset

Alarm 2 contact reset type

ArE. Automatic reset (Default)

PrE. Manual reset (reset / manual reset by keyboard) **SET**

PrE.S. Manual reset stored. (keeps relay status also after an eventual power failure)

34 *A.2.S.E.* Alarm 2 State Error

State of contact for alarm 2 output in case of error

c.o. Open contact (Default)

c.c. Closed contact

35 *A.2.Ld.* Alarm 2 Led

State of OUT2 led corresponding to relative contact

c.o. ON with open contact

c.c. ON with closed contact (Default)

36 *A.2.HY.* Alarm 2 Hysteresis

-999...+999 [digit⁷] (degrees.tenths for temperature sensors), Default: 0.0.

37 *A.2.d.E.* Alarm 2 Delay

-180...+180 seconds. Negative: delay in alarm exit phase.

Positive: delay in alarm entry phase. Default: 0.

⁷ Display of decimal point depends on setting of parameter *SEn.* and parameter *d.P.*

38 *A.25.P.* **Alarm 2 Setpoint Protection**

Alarm 2 set protection. Does not allow operator to change value set

FrEE Modification allowed (Default)

Loct Protected

HiDE Protected and not visualized

47 *E.A.* **Current Transformer**

Activation and scale range of current transformer

0 Disabled. 1-200 Ampere. Default: 0

48 *L.b.A.t.* **Loop Break Alarm Threshold**

Intervention threshold of Loop Break Alarm

0.0-200.0 Ampere. Default: 50.0

49 *L.b.A.d.* **Loop Break Alarm Delay**

Delay time for Loop break alarm intervention

00.00-60.00 mm.ss. Default: 01.00

50 *COO.F.* **Cooling Fluid**

Type of refrigerant fluid for heating / cooling P.I.D.

Air Air (Default)

Oil Oil

H2O Water

51 *P.b.M.* **Proportional Band Multiplier**

Proportional band multiplier. Proportional band for cooling action is given by parameter 18 multiplied for this parameter. 1.00-5.00 (Default: 1.00)

52 *o.u.d.b.* **Overlap / Dead Band**

Dead band combination for heating / cooling action in heating / cooling P.I.D. mode (dual action).

-20.0-50.0% of proportional band value (Default: 0).

Negative indicates dead band value. Positive means overlap.

53 *c.o.t.c.* **Cooling Cycle Time**

Cycle time for cooling output

1-300 seconds, Default: 10.

54 *c.Flt.* **Conversion Filter**

ADC Filter: Number of input sensor readings to calculate the mean that defines process value. **NB:** When readings increase, control loop speed slows down

d.i.s. Disabled

2.S.N. 2 Samples Mean

3.S.N. 3 Samples Mean

4.S.N. 4 Samples Mean

5.S.N. 5 Samples Mean

6.S.N. 6 Samples Mean

7.S.N. 7 Samples Mean

8.S.N. 8 Samples Mean

9.S.N. 9 Samples Mean

10.S.N. 10 Samples Mean (Default)

11.S.N. 11 Samples Mean

12.S.N. 12 Samples Mean

13.S.N. 13 Samples Mean

14.S.N. 14 Samples Mean

15.S.N. 15 Samples Mean

55 *c.Frq.* Conversion Frequency

Sampling frequency of analogue / digital converter.

NB: Increasing the conversion speed will slow down reading stability (ex: for fast transients, as pressure, it is advisable to increase sampling frequency)

242H. 242 Hz (Maximum speed conversion)

123H. 123 Hz

62 H. 62 Hz

50 H. 50 Hz

39 H. 39 Hz

33.2H. 33.2 Hz

19.6H. 19.6 Hz

16.7H. 16.7 Hz (**Default**) Ideal for filtering noises 50 / 60 Hz

12.5H. 12.5 Hz

10 H. 10 Hz

8.33H. 8.33 Hz

6.25H. 6.25 Hz

4.17H. 4.17 Hz (Minimum speed conversion)

56 *v.Flt.* Visualization Filter

Slow down the refresh of display, to simplify reading

d i s. Disabled with pitchfork (maximum speed of display update)

Default.

F i l t e r. First order filter with pitchfork

2. S. M. 2 Samples Mean

3. S. M. 3 Samples Mean

4. S. M. 4 Samples Mean

5. S. M. 5 Samples Mean

- 6. 5.П. 6 Samples Mean
- 7. 5.П. 7 Samples Mean
- 8. 5.П. 8 Samples Mean
- 9. 5.П. 9 Samples Mean
- 10.5.П. 10 Samples Mean (Maximum slow down of display update)
- noLL Disabled without pitchfork
- F.o. 2 First order filter

57 *тунЕ* **Tune**

Tuning type selection. (See paragraph 7.2)

- дi5.* Disabled (**Default**)
- Аuto* Automatic (P.I.D. parameters are calculated at activation and at change of set point)
- MAN.* Manual (launch by keyboard or digital IN)
- Sync.* Synchronized (see word modbus 1025)

58 *5.d.тu.* **Setpoint Deviation Tune**

Select the deviation from the command setpoint for the threshold used by autotuning to calculate the P.I.D. parameters

0-5000 [digit¹⁰] (degrees.tenths for temperature sensors). **Default:** 10.

59 *oP.Пo.* **Operating Mode**

Select operating mode. (See paragraph 7.12)

- cont.* Controller (**Default**)
- Pr.cY.* Pre-programmed cycle (See paragraph 7.7)
- 2т.5.* Setpoint change by digital input
- 2т.5. i.* Setpoint change by digital input with impulse command
- 3т.5. i.* 3 sets change by digital input with impulse command

- 4E.5. i. 4 sets change by digital input with impulse command
- t.rE5. Reset time
- P.c.5.5. Pre-programmed cycle with Start / Stop by digital input

60 A.U.ΠA. Automatic / Manual

Enable automatic / manual selection. (See paragraph 7.6)

- d i5. Disabled (Default)
- En. Enabled
- En.5E. Enabled with memory

61 dGt. i. Digital Input

Digital input functioning (P59 selection must be *cont.* or *Pr.cY*).
(See paragraph 7.12)

- d i5. Disabled (Default: 0)
- 5E.5E. Pre-programmed cycle with Start / Stop
- rn.no. Run N.O. (enables regulation with N.O. contact)
- rn.nc. Run N.C. (enables regulation with N.C. contact)
- L.c.n.o. Lock conversion N.O. (stop conversion and display value with N.O.)
- L.c.n.c. Lock conversion N.C. (stop conversion and display value with N.C.)
- t.unE Manual Tune (by digital input)
- A.ΠA. i. Auto manual impulsive (See paragraph 7.12)
- A.ΠA.c Automatic manual contact (See paragraph 7.12)

62 *GrAd.* Gradient

Rising gradient for Soft-Start or pre-programmed cycle

0 Disabled

1-9999 [Digit/hour⁸] (degrees/hour with display of tenth for temperature sensor). Default: 0.

63 *MA.ti.* Maintenance Time

Maintenance time for pre-programmed cycle

00.00-24.00 hh.mm. Default: 00.00

64 *U.M.C.P.* User Menu Cycle Programmed

Allows to modify rising gradient and maintenance time, from user menu, when pre-programmed cycle is operating

d.i.S. Disabled (Default)

GrAd. Gradient

MA.ti. Maintenance time

ALL Both gradient and maintenance time

65 *U.V.T.Y.* Visualization Type

Select visualization for display 1 and 2

I.P.2.S. 1 Process, 2 Setpoint (Default)

I.P.2.H. 1 Process, 2 Hide after 3 sec.

I.S.2.P. 1 Setpoint, 2 Process

I.S.2.H. 1 Setpoint, 2 Hide after 3 sec.

I.P.2.A. 1 Process, 2 Ampere (T.A. input)

I.P.2.D 1 Process, 2 Command output percentage

⁸ Display of decimal point depends on setting of parameter *SEn.* and parameter *d.P.*

66 *dEGr.* Degree

Select degree type

$^{\circ}C$ Centigrade (Default)

$^{\circ}F$ Fahrenheit

67 *rEt.r.* Retransmission

Retransmission for output 0-10 V or 4...20 mA (short circuit pins 8, 9, 10). Parameters 68 and 69 define the lower and upper limits of the scale.

d.i.s. Disabled

u.o.P. Retransmits process in Volt

m.A.P. Retransmits process in mA

u.o.c. Retransmits command setpoint in Volt

m.A.c. Retransmits command setpoint in mA

u.o.o.P. Volt output percentage

m.A.o.P. mA output percentage

u.o.A.1 Volt alarm 1 setpoint

m.A.A.1 mA alarm 1 setpoint

u.o.A.2 Volt alarm 2 setpoint

m.A.A.2 mA alarm 2 setpoint

u.o.t.A. Volt T.A.

m.A.t.A. mA T.A.

68 *Lo.L.r.* Lower Limit Retransmission

Output V / mA retransmission lower limit range

-999...+9999 [digit¹²] (degrees.tenths for temperature sensors),

Default: 0.

69 *uP.L.r.* **Upper Limit Retransmission**

Output V / mA retransmission upper limit range

-999...+9999 [digit⁹] (degrees.tenths for temperature sensors), **Default:** 1000.

70 *bd.rt.* **Baud Rate**

Selects baud rate for serial communication

4.8 *†* 4.800 Bit/s

9.6 *†* 9.600 Bit/s

19.2 *†* 19.200 Bit/s (**Default**)

28.8 *†* 28.800 Bit/s

39.4 *†* 39.400 Bit/s

57.6 *†* 57.600 Bit/s

71 *SL.Ad.* **Slave Address**

Selects slave address for serial communication. 1 – 254, **Default:** 254

72 *SE.dE.* **Serial Delay**

Select serial delay. 0 – 100 milliseconds. **Default:** 20

73 *LL.o.P.* **Lower Limit Output Percentage**

Selects min. value for command output percentage

0 – 100%, **Default:** 0%.

Ex: with *c.o.u.t* selected as 0...10 V and *LL.o.P.* set at 10%, command output can change from a min. of 1 V to a max. of 10 V.

⁹ *The display of the decimal point depends on the setting of parameter *SE.n.* and the parameter *d.P.**

11 Alarm Intervention Modes



Absolute Alarm or Threshold Alarm ($R. AL$ selection)

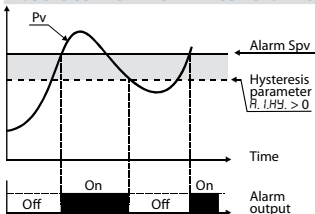

Absolute alarm with controller in heating functioning (par. 11 $RcL.E.$ selected $HEAT$) and hysteresis value greater than "0" (par. 28 $R. I.HY. > 0$).

NB¹⁰

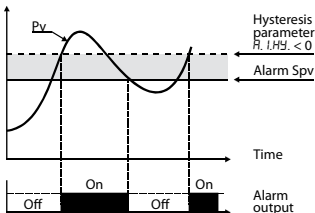

Absolute alarm with controller in heating functioning (par. 11 $RcL.E.$ selected $HEAT$) and hysteresis value less than "0" (par. 28 $R. I.HY. < 0$).

NB¹⁰

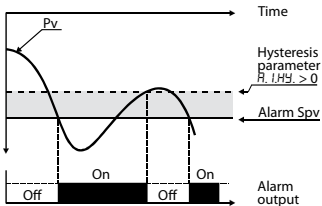

Absolute alarm with controller in cooling functioning (par. 11 $RcL.E.$ selected $COOL$) and hysteresis value than "0" (par. 28 $R. I.HY. > 0$).

NB¹⁰

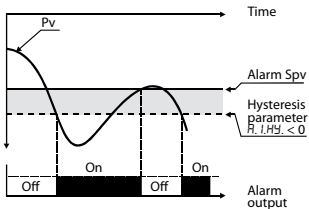

Absolute alarm with controller in cooling functioning (par. 11 *Act.E.* selected *COOL*) and hysteresis value less than "0" (par. 28 *R.I.HY.* < 0).

NB¹⁰

Absolute Alarm or Threshold Alarm Referring to Setpoint Command (*A.c.AL.* selection)

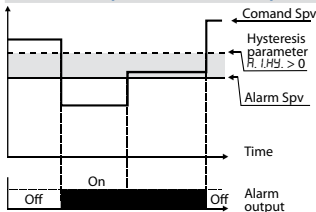

Absolute alarm refers to the command set, with the controller in heating functioning (par. 11 *Act.E.* selected *HEAT*) and hysteresis value greater than "0" (par. 28 *R.I.HY.* > 0).

The command set can be changed by pressing the arrow keys on front panel or using serial port RS485 commands.

NB¹⁰

Band Alarm (b. AL selection)

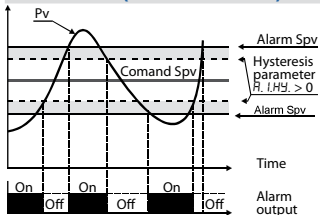

Band alarm hysteresis value greater than "0" (par. 28 $R.I.HY. > 0$).

NB¹⁰

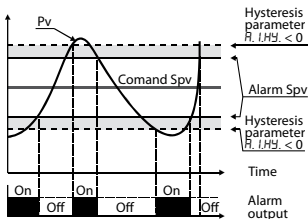

Band alarm hysteresis value less than "0" (par. 28 $R.I.HY. < 0$).

NB¹⁰

¹⁰ The example refers to alarm 1; the function can also be enabled for alarms 2 and 3 on models that include it.

Upper Deviation Alarm (H.d.AL. selection)

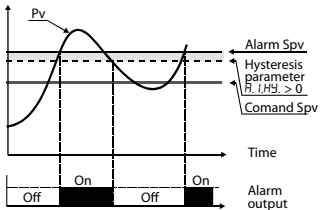

Upper deviation alarm value of alarm setpoint greater than "0" and hysteresis value greater than "0" (par. 28 $R.I.H.Y. > 0$).

NB¹⁰

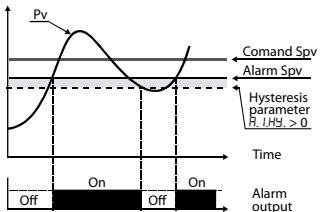

Upper deviation alarm value of alarm setpoint less than "0" and hysteresis value greater than "0" (par. 28 $R.I.H.Y. > 0$).

NB¹⁰

Lower Deviation Alarm (L.d.AL. selection)

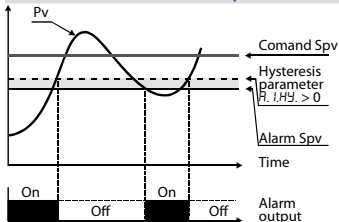

Lower deviation alarm value of alarm setpoint greater than "0" and hysteresis value greater than "0" (par. 28 $R.I.H.Y. > 0$).

NB¹¹

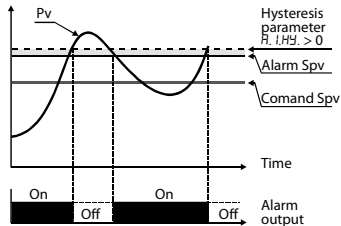

Lower deviation alarm value of alarm setpoint less than "0" and hysteresis value greater than "0" (par. 28 $R.I.H.Y. > 0$).

NB¹¹

¹¹ a) The example refers to alarm 1; the function can also be enabled for alarms 2 and 3 on models that include it.
b) With hysteresis value less than "0" ($R.I.H.Y. < 0$) the broken line moves under the alarm setpoint.

12 Table of Anomaly Signals

If installation malfunctions, controller will switch off regulation output and will report the anomaly. For example, controller will report failure of a connected thermocouple visualizing $E-05$ flashing on display for other signals, see table below.

	Cause	what to do
E-01 <i>SYS.E</i>	Error in EEPROM cell programming.	Call Assistance.
E-02 <i>SYS.E</i>	Cold junction sensor fault or room temperature outside of allowed limits.	Call Assistance.
E-04 <i>SYS.E</i>	Incorrect configuration data. Possible loss of calibration values.	Check if the configuration parameters are correct.
E-05 <i>SYS.E</i>	Thermocouple open or temperature outside of limits.	Check the connection with the sensors and their integrity.
E-08 <i>SYS.E</i>	Missing calibration data.	Call Assistance.

13 Summary of Configuration parameters

Date:

Model URDR:

Installer:

System:

Notes:

N.	Par.	Description
1	<i>c.out</i>	Command output type selection
2	<i>SEN.</i>	Analogue input configuration
3	<i>d.P.</i>	Number of decimal points

N.	Par.	Description
4	<i>LoL.S.</i>	Lower limit setpoint
5	<i>uP.L.S.</i>	Upper limit setpoint
6	<i>Lo.L. i.</i>	Lower limit range AN1 only for linear
7	<i>uP.L. i.</i>	Upper limit range AN1 only for linear
8	<i>LAEC</i>	Automatic setting of linear input limits
9	<i>o.cAL.</i>	Offset calibration
10	<i>G.cAL.</i>	Gain calibration
11	<i>REt.E.</i>	Regulation type
12	<i>c. rE.</i>	Command output reset type
13	<i>c. SE.</i>	Contact state for command output in case of error
14	<i>c. Ld.</i>	Define the OUT1 led state
15	<i>c. HY.</i>	Hysteresis in ON / OFF or dead band in P.I.D.
16	<i>c. dE.</i>	Command delay
17	<i>c. S.P.</i>	Command setpoint protection
18	<i>P.b.</i>	Proportional band
19	<i>t. i.</i>	Integral time
20	<i>t. d.</i>	Derivative time
21	<i>t. c.</i>	Cycle time
22	<i>o.PoL.</i>	Upper limit of heating output percentage
23	<i>AL. 1</i>	Alarm 1 selection
24	<i>R.I.S.o.</i>	Alarm 1 output contact and intervention type
25	<i>R.I.rE.</i>	Reset type of alarm 1 contact
26	<i>R.I.S.E.</i>	State of contact for alarm 1 output
27	<i>R.I.Ld.</i>	State of OUT2 led
28	<i>R.I.HY</i>	Alarm 1 hysteresis
29	<i>R.I.dE.</i>	Alarm 1 delay
30	<i>R.I.S.P.</i>	Alarm 1 set protection
31	<i>AL. 2</i>	Alarm 2 selection

N.	Par.	Description
32	<i>A.2.5.o.</i>	Alarm 2 output contact and intervention type
33	<i>A.2.rE</i>	Reset type of alarm 2 contact
34	<i>A.2.5.E.</i>	State of contact for alarm 2 output
35	<i>A.2.Ld.</i>	State of OUT2 led
36	<i>A.2.HY.</i>	Alarm 2 hysteresis
37	<i>A.2.dE.</i>	Alarm 2 delay
38	<i>A.2.5.P.</i>	Alarm 2 set protection alarm 2 set protection
47	<i>t.A.</i>	Activation and scale range of Current transformer
48	<i>L.b.A.t.</i>	Intervention threshold of Loop Break Alarm
49	<i>L.b.A.d.</i>	Delay time for Loop Break Alarm intervention
50	<i>coo.F.</i>	Cooling fluid type
51	<i>P.b.Π.</i>	Proportional band multiplier
52	<i>ou.d.b.</i>	Overlapping / Dead band
53	<i>co.t.c.</i>	Cycle time for cooling output
54	<i>c.FLt.</i>	Analog converter filter
55	<i>c.Frn.</i>	Sampling frequency of analog converter
56	<i>u.FLt.</i>	Display filter
57	<i>tUnE</i>	Autotuning type selection
58	<i>S.d.t.u.</i>	Command setpoint deviation for tuning threshold
59	<i>oP.Πo</i>	Operating mode
60	<i>Au.ΠA.</i>	Automatic / manual selection
61	<i>dGt. i.</i>	Digital input functioning
62	<i>GrAd.</i>	Gradient for Soft-Start
63	<i>ΠA.t i.</i>	Cycle maintenance time
64	<i>u.Π.c.P.</i>	Gradient change and maintenance time by user
65	<i>u i.tY.</i>	Display data selection
66	<i>dEGr.</i>	Degree type selection
67	<i>rEt.r.</i>	Retransmission for output 0-10 V or 4...20 mA

N.	Par.	Description
68	<i>Lol.r.</i>	Lower limit range for linear output
69	<i>uPl.r.</i>	Upper limit range for linear output
70	<i>bd.r.t.</i>	Select baud rate for serial communication
71	<i>Sl.Ad.</i>	Select slave address
72	<i>SE.dE.</i>	Select the serial delay
73	<i>L.L.o.P.</i>	Lower limit of heating output percentage

Notes / Updates



Wachendorff Prozesstechnik GmbH & Co. KG
Industriestrasse 7 • D-65366 Geisenheim

Tel.: +49 (0) 67 22 / 99 65 - 20

Fax: +49 (0) 67 22 / 99 65 - 78

E-Mail: efdi@wachendorff.de

www.wachendorff-prozesstechnik.de

