

# User Manual

Revision 2.101  
English

## CAN Repeater for generic use (Standard and Extended Protocol)

(Order Code: HD67181 – HD67181M – HD67181-M12)

for Website information:

[www.adfweb.com?Product=HD67181](http://www.adfweb.com?Product=HD67181)

for Price information:

[www.adfweb.com?Price=HD67181](http://www.adfweb.com?Price=HD67181)

### Benefits and Main Features:

- ▶ Designed for serious use
- ▶ Low cost
- ▶ Electrical isolation of CAN branches
- ▶ Extension of nodes number
- ▶ Different baud rate of branches CAN
- ▶ Allows extension of a line segment (without lowering the Baud Rate)
- ▶ Protocol independent, allowing it to work with all the different CAN protocols and frame lengths.



HD67181



HD67181M



HD67181-M12

Similar  
Products



Benefits



For others Repeaters:

#### CAN Repeaters

See also the following links:

[www.adfweb.com?Product=HD67117](http://www.adfweb.com?Product=HD67117)

(For CANopen)

[www.adfweb.com?Product=HD67180](http://www.adfweb.com?Product=HD67180)

(For DeviceNet)

[www.adfweb.com?Product=HD67182](http://www.adfweb.com?Product=HD67182)

(For J1939)

#### Optic Fibres Repeaters

See also the following links:

[www.adfweb.com?Product=HD67117F](http://www.adfweb.com?Product=HD67117F)

(For CANopen)

[www.adfweb.com?Product=HD67117FS](http://www.adfweb.com?Product=HD67117FS)

(For CANopen)

[www.adfweb.com?Product=HD67180F](http://www.adfweb.com?Product=HD67180F)

(For DeviceNET)

[www.adfweb.com?Product=HD67180FS](http://www.adfweb.com?Product=HD67180FS)

(For DeviceNET)

[www.adfweb.com?Product=HD67181F](http://www.adfweb.com?Product=HD67181F)

(For CAN 2.0A & 2.0B)

[www.adfweb.com?Product=HD67181FS](http://www.adfweb.com?Product=HD67181FS)

(For CAN 2.0A & 2.0B)

[www.adfweb.com?Product=HD67182F](http://www.adfweb.com?Product=HD67182F)

(For J1939)

[www.adfweb.com?Product=HD67182FS](http://www.adfweb.com?Product=HD67182FS)

(For J1939)

[www.adfweb.com?Product=HD67221F](http://www.adfweb.com?Product=HD67221F)

(Copper Bridge)

[www.adfweb.com?Product=HD67221FS](http://www.adfweb.com?Product=HD67221FS)

(Copper Bridge)

Do you have an your customer protocol?

See the following links:

[www.adfweb.com?Product=HD67003](http://www.adfweb.com?Product=HD67003)

Do you need to choose a device? do you want help?

Ask it to the following link:

[www.adfweb.com?Cmd=helpme](http://www.adfweb.com?Cmd=helpme)

**INDEX:**

	Page
UPDATED DOCUMENTATION	2
REVISION LIST	2
WARNING	2
TRADEMARKS	2
INDEX	2
CHARACTERISTICS	3
EXAMPLES	4
SET SWITCH BAUD RATE	6
CONNECTION SCHEME	7
CAN BUS CABLE CHARACTERISTICS	10
MECHANICAL DIMENSIONS	11
ORDER CODE	12
WARRANTIES AND TECHNICAL SUPPORT	13
RETURN POLICY	13
PRODUCTS AND RELATED DOCUMENTS	13

**UPDATED DOCUMENTATION:**

Dear customer, we thank you for your attention and we remind you that you need to check that the following document is:

- Updated
- Related to the product you own

To obtain the most recently updated document, note the "document code" that appears at the top right-hand corner of each page of this document.

With this "Document Code" go to web page [www.adfweb.com/download/](http://www.adfweb.com/download/) and search for the corresponding code on the page. Click on the proper "Document Code" and download the updates.

To obtain the updated documentation for the product that you own, note the "Document Code" (Abbreviated written "Doc. Code" on the label on the product) and download the updated from our web site [www.adfweb.com/download/](http://www.adfweb.com/download/)

**REVISION LIST:**

Revision	Date	Author	Chapter	Description
1.002	16/02/2006	Dp	All	Revision
1.005	19/06/2005	Ddt	All	documentation code changed
1.006	22/06/2007	Av	All	Revision
1.007	26/06/2007	Av	All	Revision
1.100	29/06/2007	Av	All	Enclosure Small
2.000	06/07/2007	Av	All	New document format
2.100	03/11/2008	Fl	All	Type M12
2.101	19/01/2009	Fl	All	Revision

**WARNING:**

ADFweb.com reserves the right to change information in this manual about our product without warning.  
ADFweb.com is not responsible for any error this manual may contain.

**TRADEMARKS:**

All trademarks mentioned in this document belong to their respective owners.

**CHARACTERISTICS:**

Resolved your extension line problems.  
Ideal for galvanized isolation.  
Two-sided programmable baudrate.  
Adapted for use in motors and devices with electro-magnetic disturbances.

Adapted as repeaters for the following lines: **CANopen, Devicenet, J1939, CAN bus 2.0A, CAN bus 2.0B** and generic **ISO 11898** standard

The CAN Repeater have 4 order code: **HD67117, HD67180, HD67181, HD67182**. So they are more proper to a protocol rather than to another.

**The CAN Repeater (for all the order code):**

- Electrical isolation of two branches of a CAN Line (ISO 11898-1);
- Allows extension of a line segment without lowering the Baud rate;
- Interconnects two branches of different speeds;
- Uses a microprocessor for the organization of data;
- Independent Protocol;
- Possible different baud rate setting (into different branches);
- Mountable on Rail DIN;
- Power Supply 24VDC 200mA; 12/18V AC 50/60Hz; 200mA;
- Temperature range -30°C to 70°C;
- EMS EN 61000-6-2.

**EXAMPLES:**

**Example Repeater use**

**DIFFERENT BAUD RATE ON BRANCHES CAN**



**Examples Repeater use**

**EXTENDED LINE CAN**

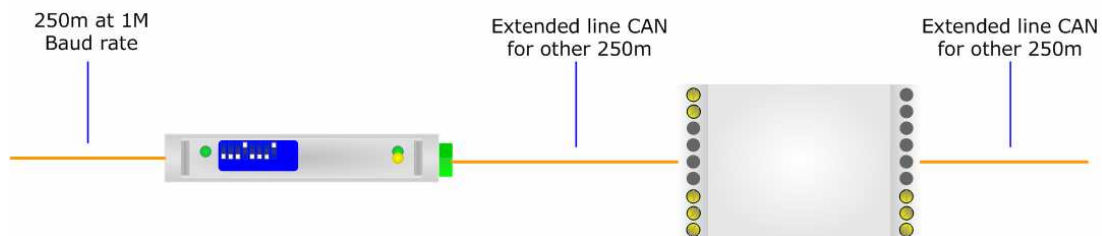

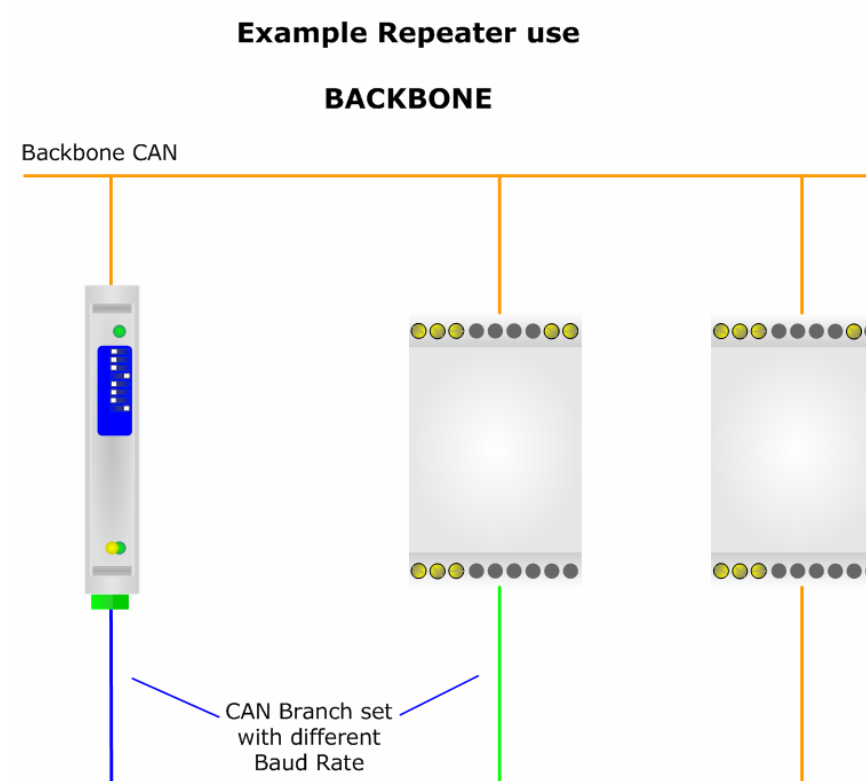

**SET SWITCH BAUD RATE:**

The switches for setting the CAN0 baud Rate and CAN1 on the front panel of the device.

**Dip n° 1, 2, 3, 4 CAN1 setting**

**Dip n° 5, 6, 7, 8 CAN0 setting**

Speed CAN1 BPS	Dip 1	Dip 2	Dip 3	Dip 4
Speed CAN0 BPS	Dip 5	Dip 6	Dip 7	Dip 8
10K	ON	OFF	OFF	OFF
20K	OFF	ON	OFF	OFF
50K	ON	ON	OFF	OFF
(*) 62.5K	OFF	ON	OFF	ON
100K	OFF	OFF	ON	OFF
125K	ON	OFF	ON	OFF
250K	OFF	ON	ON	OFF
500K	ON	ON	ON	OFF
800K	OFF	OFF	OFF	ON
1000K	ON	OFF	OFF	ON

(\*) Feature, not available in old devices ( before March 15th 2007).

**CONNECTION SCHEMES:**

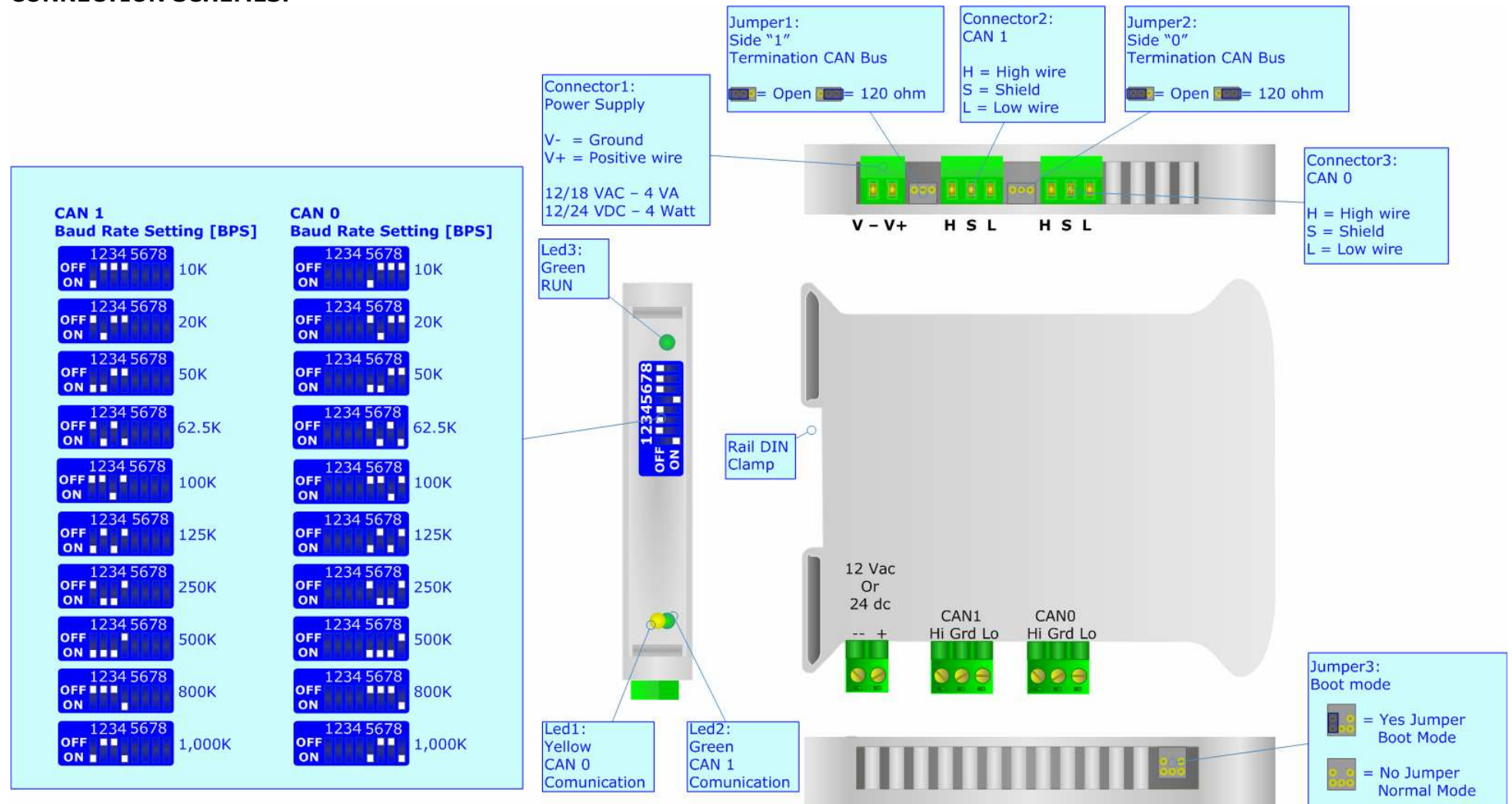

Figure 1: Connection scheme for HD67181

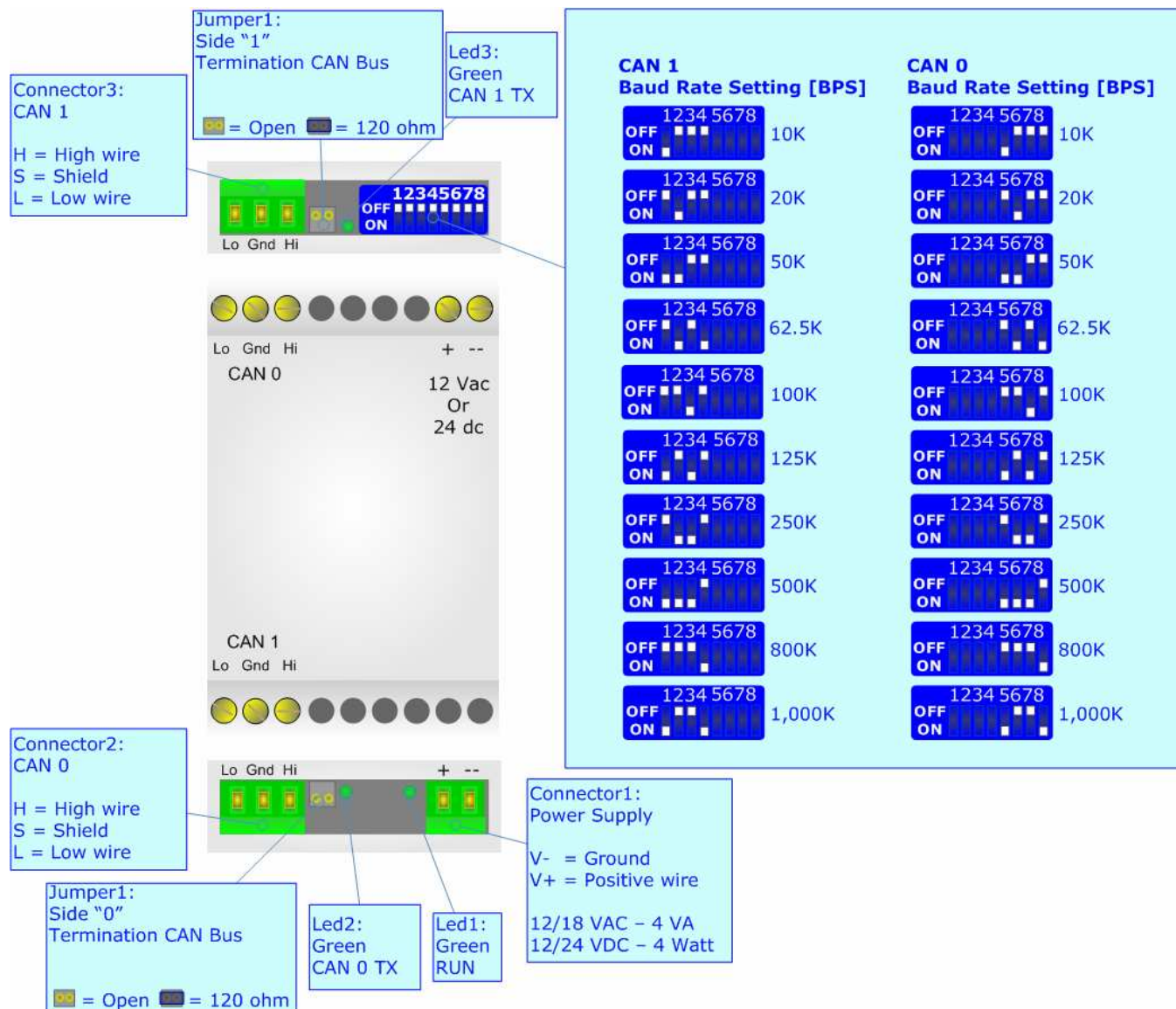

Figure 2: Connection scheme for HD67181M



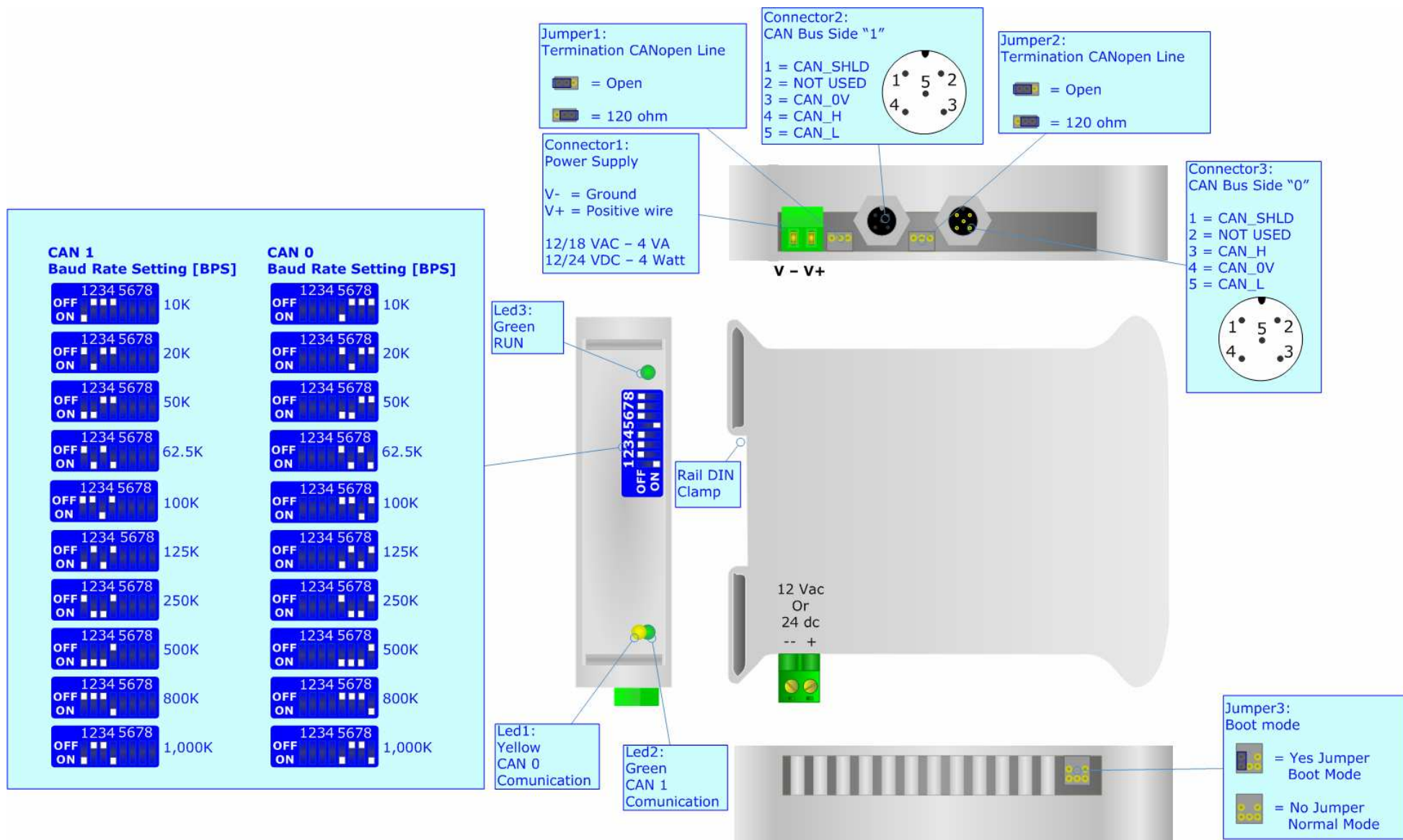

Figure 3: Connection scheme for HD67181-M12

**CAN BUS CABLE CHARACTERISTICS:**

<b>DC parameter:</b>	Impedance	70 ohm/m
<b>AC parameters:</b>	Impedance	120 ohm/m
	Delay	5 ns/m
<b>Length</b>	<b>Baud Rate [bps]</b>	<b>Length MAX [m]</b>
	10 K	5000
	20 K	2500
	50 K	1000
	100 K	650
	125 K	500
	250 K	250
	500 K	100
	800 K	50
	1000 K	25

**MECHANICAL DIMENSIONS:**

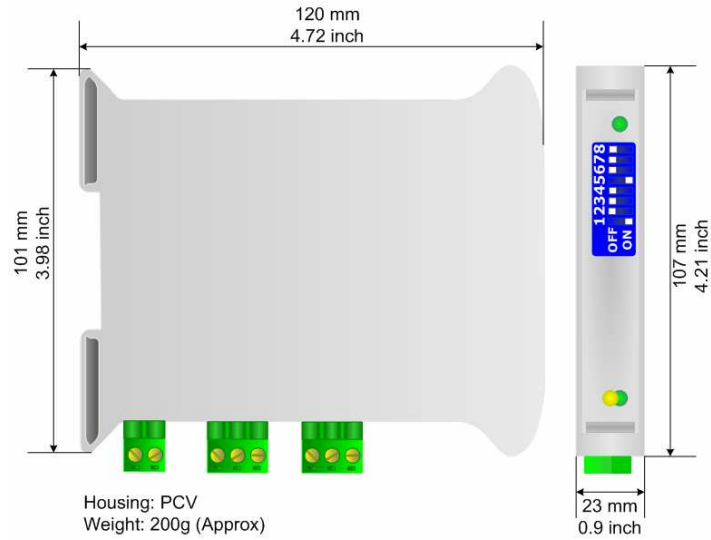

Figure 4: Mechanical dimensions scheme for HD67181

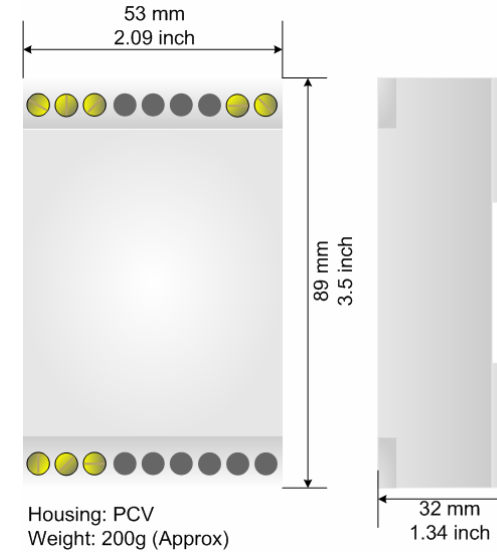

Figure 5: Mechanical dimensions scheme for HD67181M

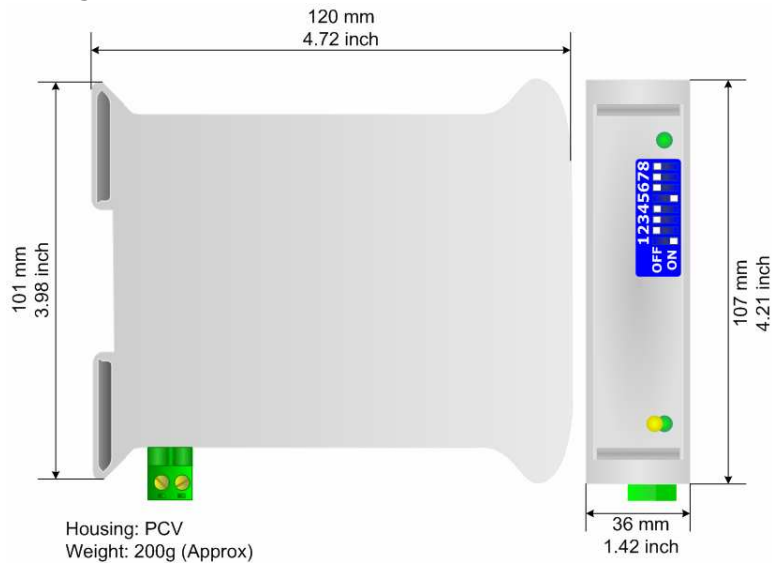

Figure 6: Mechanical dimensions scheme for HD67181-M12

**ORDER CODES:**

- HD67117** - Suitable for use with CANopen Protocol (CAN connector: Terminal block)  
**HD67117M** - Suitable for use with CANopen Protocol  
**HD67117-M12** - Suitable for use with CANopen Protocol (CAN connector: M12)
- HD67180** - Suitable for use with DeviceNet Protocol (CAN connector: Terminal block)  
**HD67180M** - Suitable for use with DeviceNet Protocol  
**HD67180-M12** - Suitable for use with DeviceNet Protocol (CAN connector: M12)
- HD67181** - Suitable for use with CAN 2.0A and 2.0B Protocol (CAN connector: Terminal block)  
**HD67181M** - Suitable for use with CAN 2.0A and 2.0B Protocol  
**HD67181-M12** - Suitable for use with CAN 2.0A and 2.0B Protocol (CAN connector: M12)
- HD67182** - Suitable for use with J1939 Protocol (CAN connector: Terminal block)  
**HD67182M** - Suitable for use with J1939 Protocol  
**HD67182-M12** - Suitable for use with J1939 Protocol (CAN connector: M12)

**WARRANTIES AND TECHNICAL SUPPORT:**

For fast and easy technical support for your ADFweb.com SRL products, consult our internet support at [www.adfweb.com](http://www.adfweb.com). Otherwise contact us at the address [support@adfweb.com](mailto:support@adfweb.com)

**RETURN POLICY:**

If while using your product you have any problem and you wish to exchange or repair it, please do the following:

- 1) Obtain a Product Return Number (PRN) from our internet support at [www.adfweb.com](http://www.adfweb.com). Together with the request, you need to provide detailed information about the problem.
- 2) Send the product to the address provided with the PRN, having prepaid the shipping costs (shipment costs billed to us will not be accepted).

If the product is within the warranty of twelve months, it will be repaired or exchanged and returned within three weeks. If the product is no longer under warranty, you will receive a repair estimate.

**PRODUCTS AND RELATED DOCUMENTS:**

Part	Description	URL
HD67121	Gateway CANopen / Canopen	<a href="http://www.adfweb.com?Product=HD67121">www.adfweb.com?Product=HD67121</a>
HD67001 HD67002	Gateway CANopen / Modbus - RTU	<a href="http://www.adfweb.com?Product=HD67001">www.adfweb.com?Product=HD67001</a>
HD67004 HD67005	Gateway CANopen / Modbus - Ethernet TCP	<a href="http://www.adfweb.com?Product=HD67004">www.adfweb.com?Product=HD67004</a>
HD67134	Gateway CANopen / DeviceNet	<a href="http://www.adfweb.com?Product=HD67134">www.adfweb.com?Product=HD67134</a>
HD67216	CAN Analyzer	<a href="http://www.adfweb.com?Product=HD67216">www.adfweb.com?Product=HD67216</a>