

# **JUMO Wtrans B**

Programmable head transmitter  
with radio transmission



**B 70.7060.0**  
Operating Manual





<b>1</b>	<b>Introduction</b>	<b>5</b>
1.1	Safety information	5
1.2	Description	6
1.3	Block diagram	6
1.4	Dimensions	7
1.4.1	Transmitter	7
1.4.2	Antenna-battery case	7
1.5	Connection elements and connectors	8
<b>2</b>	<b>Identifying the instrument version</b>	<b>9</b>
2.1	Rating plate	9
2.2	Order details	10
2.3	Scope of delivery	10
2.4	Accessories	10
<b>3</b>	<b>Probe preparation</b>	<b>11</b>
3.1	Fitting/exchanging the battery	11
3.2	Safety information concerning lithium batteries	13
3.3	Battery service life	13
3.4	Disposal of lithium batteries	13
<b>4</b>	<b>Probe range</b>	<b>15</b>
4.1	General information about radio transmission	15
4.2	Possible impairment of radio transmission	16
<b>5</b>	<b>Installation</b>	<b>19</b>
5.1	Information about fastening, securing and arrangement	19
5.2	Installing the antenna-battery case	20
5.3	Installing the transmitter	21
5.4	Aligning the antenna	22
<b>6</b>	<b>Electrical connection</b>	<b>23</b>
6.1	Safety information	23
6.2	Connection elements and connectors	24
6.3	Connection diagram	25
6.3.1	Voltage supply	25
6.3.2	Analog inputs	25
6.3.3	Output	26
6.3.4	Interface	26
<b>7</b>	<b>Setup program</b>	<b>27</b>

# Contents

---

7.1	General information about the setup program	27
7.2	Hardware and software prerequisites	28
7.3	Establishing the connection between PC and probe	29
7.4	Probe configuration	32
7.4.1	Establishing the communication	32
7.4.2	Reading the current probe parameters	33
7.4.3	Editing probe parameters	33
7.4.4	Transmitting new parameters to the probe	34
7.5	ParametersOverview	35
<b>8</b>	<b>Supplement</b>	<b>37</b>
8.1	Technical data	37
8.1.1	Analog inputs	37
8.1.2	Output (radio transmission)	39
8.1.3	Electrical data	39
8.1.4	Environmental influences	40
8.1.5	Case	40

## 1.1 Safety information

### General information

This manual contains information that must be observed in the interest of your own safety and to avoid damage to assets. This information is supported by symbols which are used in this manual as follows.

Please read this manual before commissioning the device. Keep the manual in a place accessible to all users at all times.

If difficulties occur during commissioning, please refrain from carrying out any manipulations that could jeopardize your warranty rights.

### Warning signs



#### **CAUTION!**

This symbol in combination with the signal word indicates that **damage to assets or data loss** will occur if suitable precautions are not taken.

### Note signs



#### **TIP!**

This symbol refers to **important information** about the product or its handling or additional use.



#### **REFERENCE!**

This symbol refers to **Further information** in other sections, chapters or manuals.

# 1 Introduction

## 1.2 Description

The head transmitter, type "Wtrans B", designed for industrial applications consists of the transmitter with integrated transmission unit and an antenna-battery case. The transmitter is designed for integration into the connection heads, form B. Integration into customer-specific connection heads is also possible. The antenna-battery case is installed on the connection head via a thread (M20x1.5).

The measured value is transmitted wireless to the receiver of the Wtrans system, displayed on the LCD display and provided on the receiver via the RS485 interface as well as an analog output. The radio frequency within the ISM band (Industrial, Scientific and Medical Band) is 868.4 MHz. This frequency is almost insensitive to external interferences and allows transmission even in a rough industrial environment. When using the antenna wall holder with the 3 meter long cable for the receiver, the maximum open air range is 300 m.

A lithium battery 3.6 V, 2.2 Ah (size AA) is used for the transmitter power supply.

Transmitter (probe) and receiver can be configured with the optional setup program (probe ID, transmission interval, measuring range and, if necessary, probe type). The configuration data can be archived on data carriers and printed. Changed parameters can be overwritten again with the factory settings at any time. The connection between transmitter and PC is established via a PC interface (USB/TTL or TTL/RS232 converter).

## 1.3 Block diagram

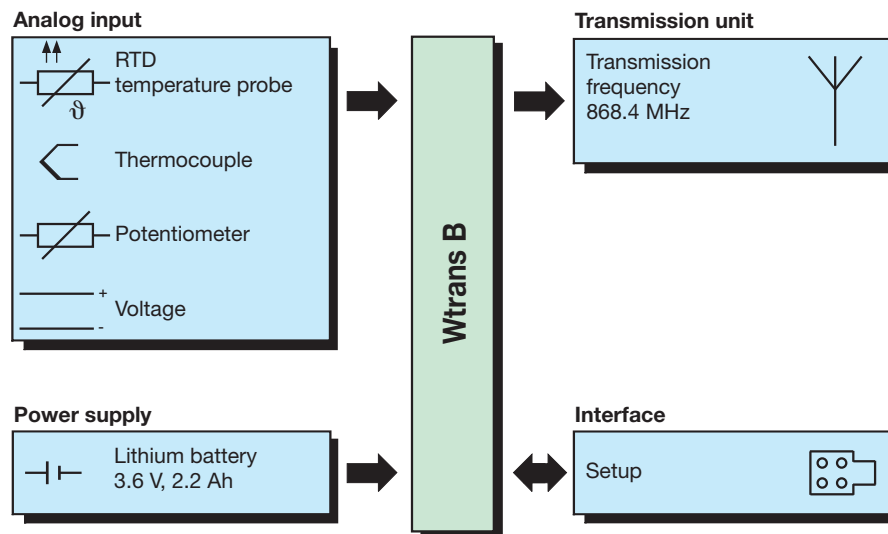

## 1.4 Dimensions

### 1.4.1 Transmitter

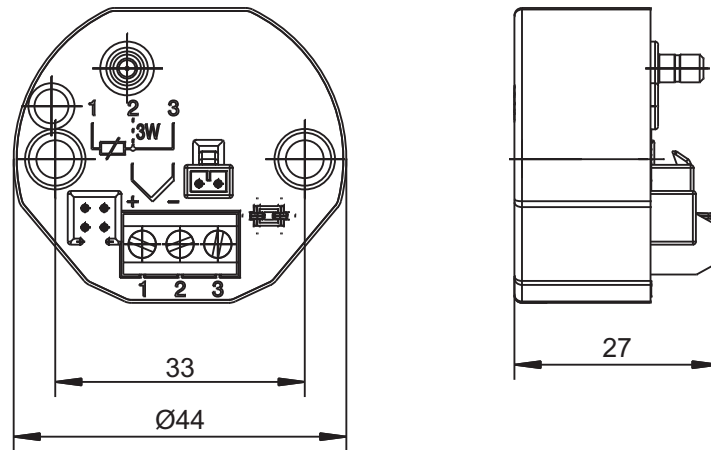

### 1.4.2 Antenna-battery case

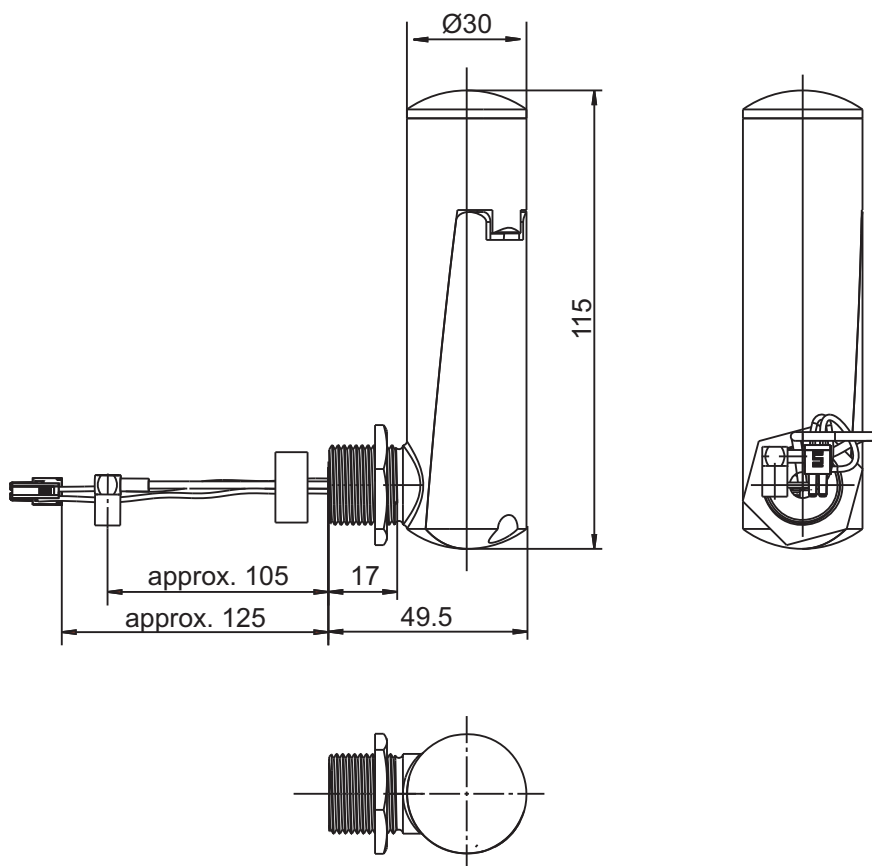

# 1 Introduction

---

## 1.5 Connection elements and connectors

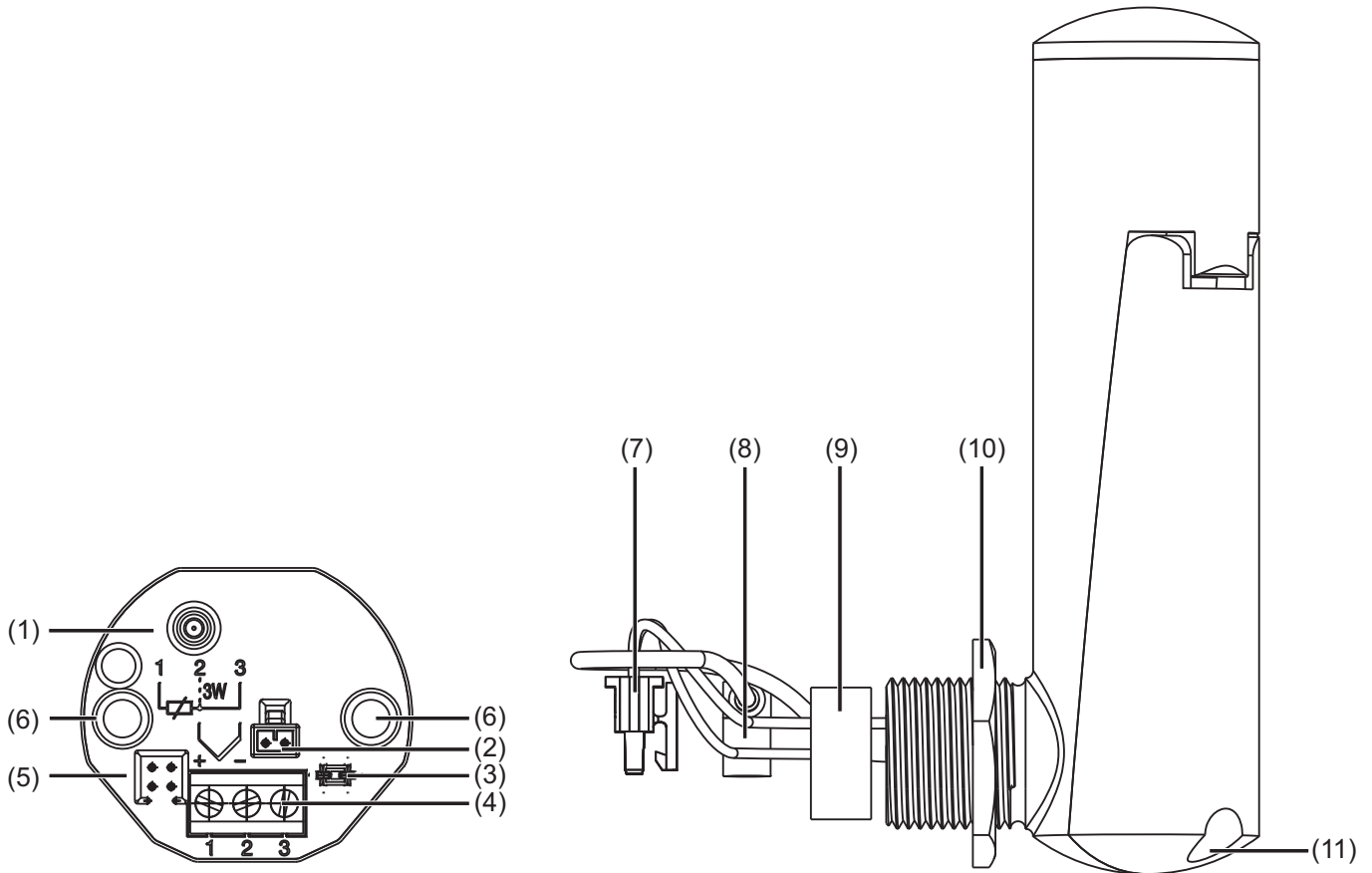

- (1) SMB antenna connector (antenna connection)
- (2) Voltage supply connector (battery connection)
- (3) Cable guide for antenna cable and voltage supply
- (4) Probe connection
- (5) Setup connector
- (6) Fastening holes for installation in the connection head, form B

- (7) Voltage supply socket (battery connection)
- (8) SMB antenna socket (antenna connection)
- (9) Seal
- (10) Locknut
- (11) Battery lid screw

# 2 Identifying the instrument version

## 2.1 Rating plate

### Position

The rating plate is glued laterally to the transmitter.  
The factory set probe ID is additionally stated on a sign fitted on top of the transmitter.

### Contents

The rating plate contains important information. This includes, among others:

Description	Designation on the rating plate	Example
Device type	Type	707060/8-10/000
Sales No.	VARTN	70/XXXXXXXX
Serial No.	F-No	0070033801210220006
Voltage supply		DC 3.6 V
Probe ID		123
Transmission frequency		868.4 MHz

### Device type

Compare the specifications on the rating plate to your order documents. The supplied device version can be identified using the type key in Chapter 2.2 "Order details", page 10.

### Sales No. (VARTN)

The Sales No. provides an unambiguous definition of an article from the catalog. It is important for communication between the sales department and the customer.

### Serial No. (F-No.)

The serial number (F-No.) indicates, among others, the production date (year/week) and the hardware version number.

### Production date

Example: F-No. = 00700338012**1022**0006

The figures concerned are in positions 12, 13, 14, 15 (from the left).

Thus the device was produced in the 22nd calendar week in 2010.

### Probe ID

The probe ID is factory set. It must be entered and activated on the receiver to establish communication between the probe and receiver. The probe ID can be changed to customer specific requirements using the setup program. The user must exclude that several probes with identical probe IDs are active.

### Transmission frequency

The transmission frequency identifies the frequency and frequency band used by the device for transmission. In the 868 MHz ISM band (Europe), the transmission is carried out at 868.4 MHz.

## 2 Identifying the instrument version

### 2.2 Order details

<b>(1) Basic type</b>	
707060	JUMO Wtrans B Programmable head transmitter with radio transmission <sup>a</sup>
<b>(2) Input</b>	
8	Standard, with factory settings
9	Customized programming according to specification <sup>b</sup>
<b>(3) Output (probe)</b>	
10	Transmission frequency 868.4 MHz (Europe)
<b>(4) Extra codes</b>	
000	none

<sup>a</sup> The connection head, form B, is not included in the delivery scope.

<sup>b</sup> Please specify the probe ID, transmission interval, measuring range and the probe type in plain text.

	<b>(1)</b>	<b>(2)</b>	<b>(3)</b>	<b>(4)</b>
<b>Order code</b>	<input type="text"/>	/	<input type="text"/>	-
<b>Order example</b>	707060	/	8	-
			10	/
				000

### 2.3 Scope of delivery

1 transmitter in the version ordered, without connection head, form B, including fastening material (2 screws and 2 pressure springs)
1 antenna-battery case with reverse battery protection plug-in connectors
1 lithium battery 3.6 V, 2.2 Ah (size AA), operational, inserted in the antenna-battery case
1 Operating manual B70.7060.0

### 2.4 Accessories

Article	Sales article No.
Lithium battery 3.6 V, 2.2 Ah (size AA)	70/00547559
PC interface with USB/TTL converter, adapter (socket connector) and adapter (pins)	70/00456352
PC interface with TTL/RS232 converter and adapter (socket connector)	70/00350260
Setup program on CD-ROM, multilingual	70/00488887
Setup program including OnlineChart on CD-ROM, multilingual	70/00549067
OnlineChart activation	70/00549188

### 3.1 Fitting/exchanging the battery

**CAUTION!**

Ensure that soiling, moisture and vapors cannot enter the device.  
The device could be destroyed.

When inserting/changing the lithium battery, ensure that the device is not exposed to soiling, moisture and vapors.

**CAUTION!**

The probe does not function, if the poles are incorrectly connected.  
The battery and the probe electronics could be damaged.

Ensure that the poles are correctly connected.

**CAUTION!**

Incorrect batteries put safety at risk.

The device could be destroyed when using incorrect batteries.

Only use the lithium battery available as accessories.

Power supply of the probe is provided by the included 3.6 V, 2.2 Ah lithium battery inserted in the antenna-battery case ready for use.

Battery service life depends on the set transmission interval and the ambient temperature: approx. 1 year with the factory-set values (transmission interval 15 s) and room temperature.

### 3 Probe preparation

If the battery was removed or must be replaced, proceed as follows:

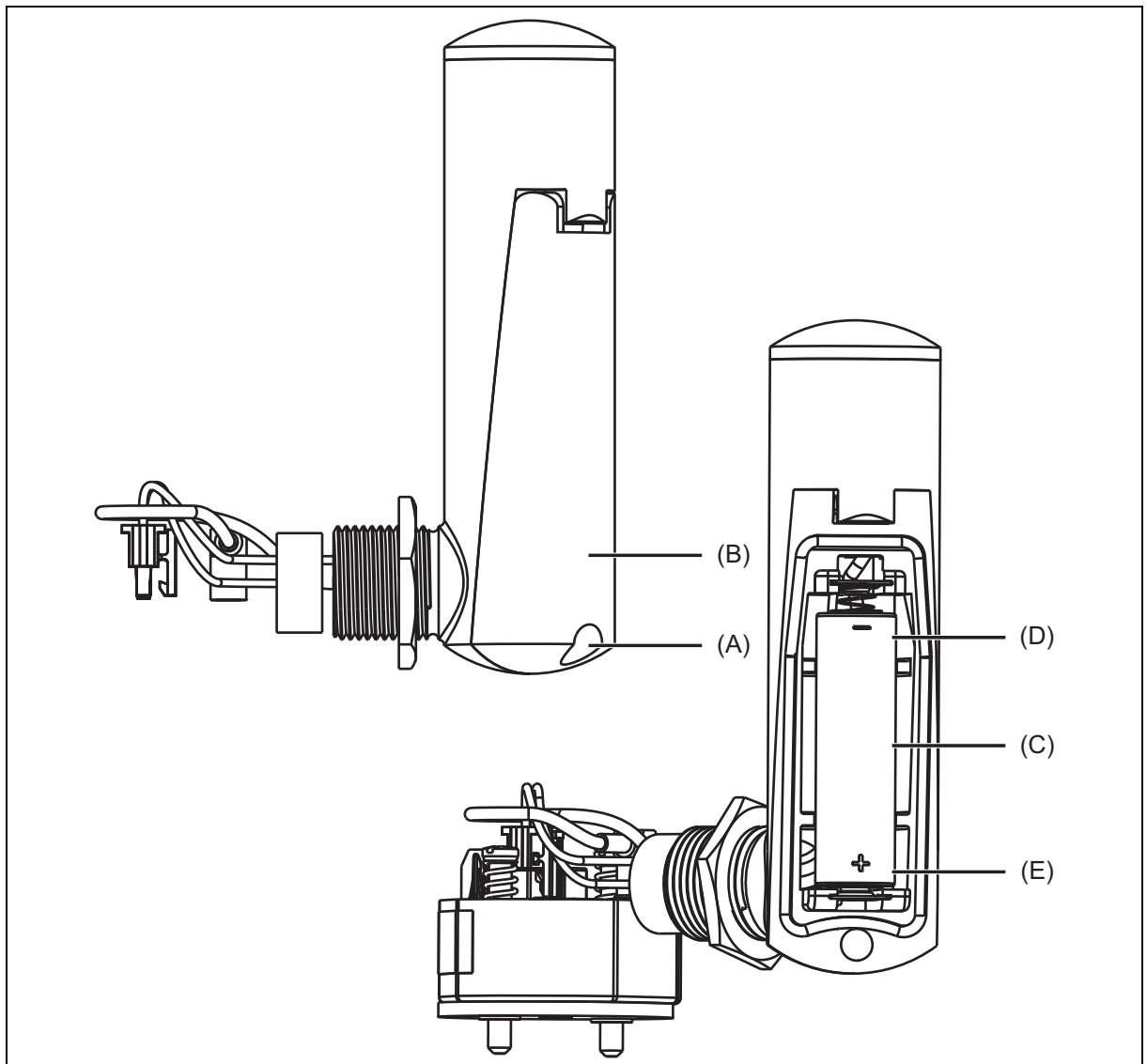

Step	Activity
1	Undo the battery lid screw (A) on the antenna-battery case and open the case lid (B).
2	Press on the battery in the area of the minus pole (D) to remove the battery (C).
3	When inserting a battery, always insert the minus pole (D) side first followed by the plus pole (E).
4	Close the case lid (B) again and ensure the correct seal position.
5	Retighten the battery lid screw (A).

### 3.2 Safety information concerning lithium batteries

⇒ <http://batterie.jumo.info>

### 3.3 Battery service life

The battery service life, depending on the transmission interval (2 s, 15 s, 30 s, 90 s) and the ambient temperature, are shown in the following figure.

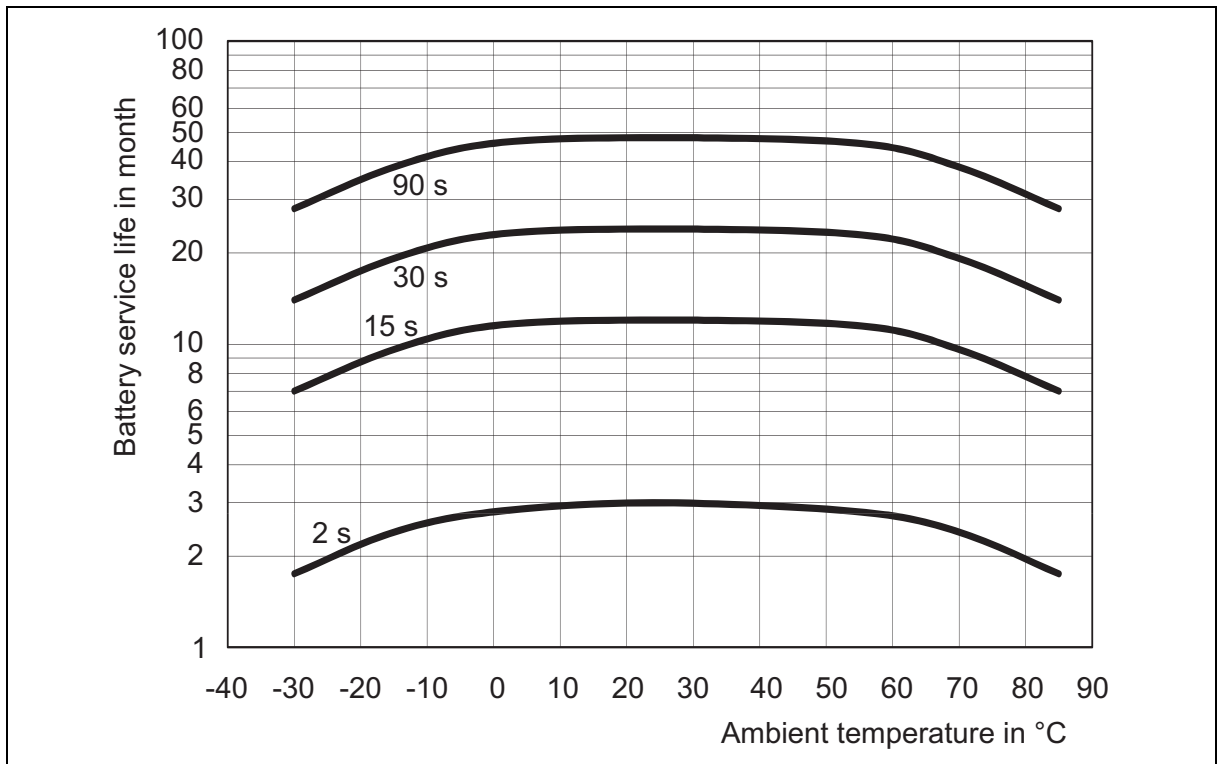

### 3.4 Disposal of lithium batteries

Please dispose of all batteries according to the Life-Cycle Resource Management and Waste Act and the national regulations.

Insulate the contacts of lithium batteries not completely discharged. Disposal of batteries together with domestic waste is expressly prohibited. Batteries can be deposited at communal waste collection points or the local retailers.

## 3 Probe preparation

---

### 4.1 General information about radio transmission

Radio signals are electromagnetic waves the signal of which will become weaker on their path from the probe to the receiver (this is termed as path attenuation). The field strength reduces inversely proportional in relation to the square of the distance between the probe and receiver.

In addition to this natural range restriction, a reduced range can also be the result of the following causes:

- Ferroconcrete walls, metallic objects and surfaces, heat insulation or windows with vapor deposited metal layer reflect and absorb electromagnetic waves and, for this reason, a deadspot is formed behind.
- Metal tubes, chains, etc. on the probe housing, for this reason, do not fasten any metallic objects on the probe housing.
- Insufficient spacing between several probes, for this reason, ensure a minimum spacing of 20 cm.
- The antenna is installed at an insufficient height; install as high as possible above the floor and ensure visual contact between the probe and receiver.

The following values are reference values concerning permeability of radio signals:

Material	Permeability
Wood, plaster, glass uncoated	90 to 100 %
Brickwork, press boards	65 to 95 %
Armored concrete	10 to 90 %
Metal, aluminum lamination	0 to 10 %

The maximum range between the probe and the receiver is 300 m in open air and when using the antenna wall holder for the receiver. The optimum reception can be achieved, if visual contact can be established between the probe and receiver.

If the receiver is installed into a switch cabinet, behind concrete walls or concrete ceilings, the antenna must always be installed with the wall holder and antenna cable for the receiver pointing in the direction of the probes.

# 4 Probe range

## 4.2 Possible impairment of radio transmission

### Collisions when using an excessive number of probes

When using a large number of probes, do not select a transmission interval which is too low, otherwise the radio channel will be unnecessarily occupied. A too low transmission interval means a very high data volume on the selected frequency which can lead to collisions with other probes. Telegrams can be destroyed during radio transmission caused by collisions.

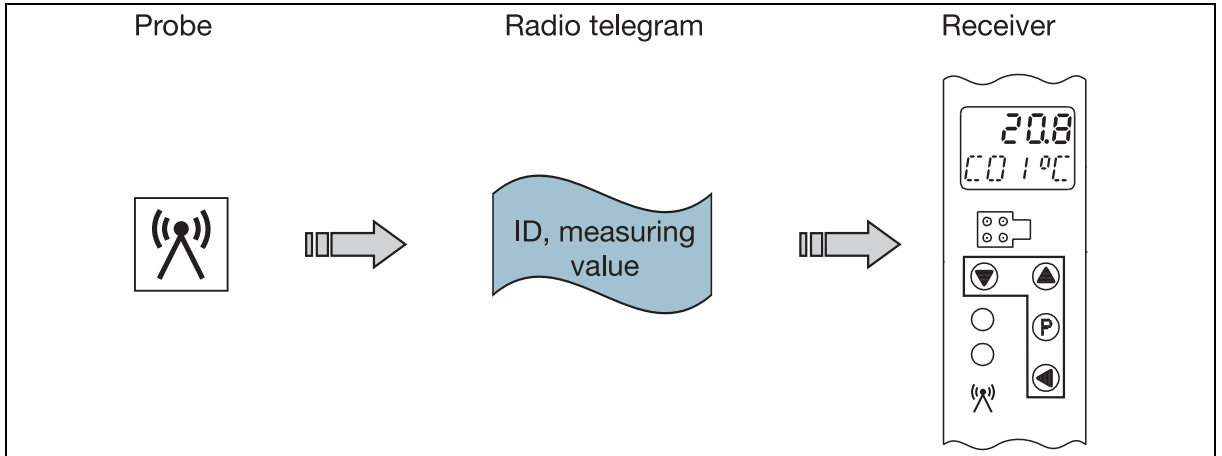

Figure 1: The telegrams of a probe reach the receiver without collisions.

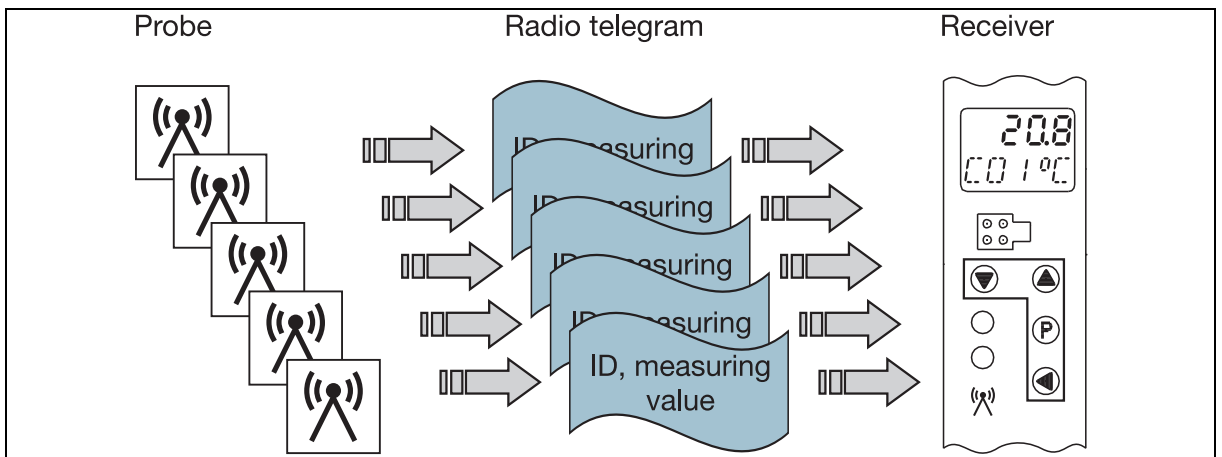
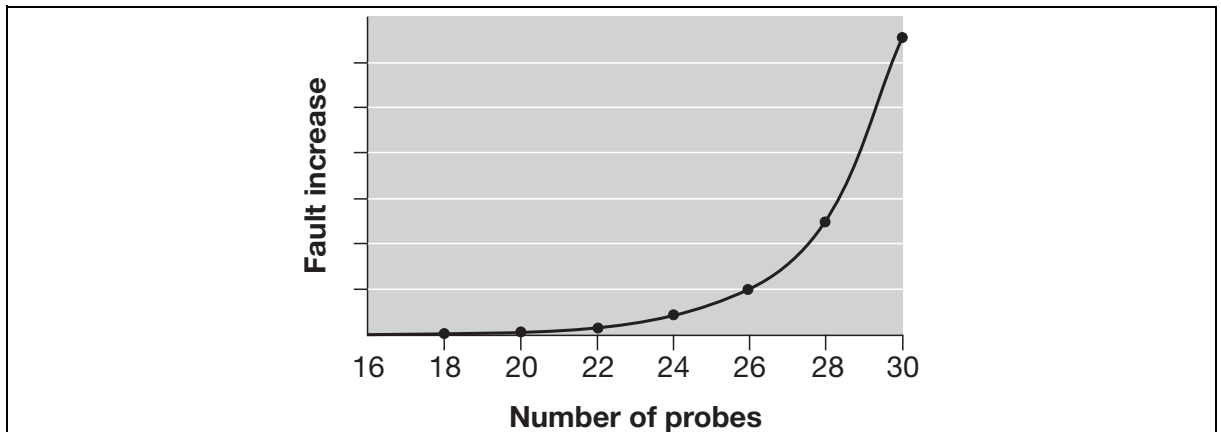

Figure 2: Telegrams of several probes can collide.



**Figure 3:** Collisions depending on the number of probes at a transmission interval of 1 s

As the figure shows 3, the error curve increases sharply once 24 probes are reached. For this reason, we recommend using a maximum of 16 probes for the smallest transmission interval of 1 s. For the factory setting of 15 s, a considerably larger number of probes is possible.

### Estimation of the maximum number of probes

If more than the recommended 16 probes are to be used at a transmission interval of 1 s, select a higher transmission interval to prevent an increased error quota.

Example:

16 probes at a transmission interval of 1 s = 32 probes at a transmission interval of 2 s

When the number of probes is to be increased additionally, the following calculation results in the next example:

Example:

16 probes at a transmission interval of 1 s = 48 probes at a transmission interval of 3 s (theoretically)

However, from a transmission interval of  $\geq 3$  s, the telegram is transmitted twice. For this reason, the number of probes to be used is cut in half.

16 probes at a transmission interval of 1 s = 24 probes at a transmission interval of 3 s (effectively)

The identical behavior occurs from a transmission interval of  $\geq 60$  s. From this transmission interval, the telegram is transmitted three times.

### External probes

The ISM band can also be used freely by other devices. External probes can transmit on the same frequency. If, for example, the probe and an external probe transmit their radio telegrams at the same time, the telegrams are destroyed. Due to the fact, that the probes are not able to check their own active transmission, no error is detected.

### Electrical devices

In a rough industrial environment, radio telegrams can be destroyed, for example, by frequency converters, electrical welding equipment or poorly shielded PCs, audio/video devices, electronic transformers, electronic ballasts, etc.

## 4 Probe range

---

### Error map-out

The radio transmission timeout parameter on the receiver can be used to map out lost telegrams (either by external influence or collisions caused by a large number of probes) and no error message appears. The value received last is retained over 2...10 transmission intervals and the alarm radio transmission timeout is only then activated (display "----").



#### **TIP!**

In the event of collisions caused by an excessive number of probes, observe and, if necessary, correct the factors "number of probes", "transmission intervals" and, on the receiver, "radio transmission timeout".

### 5.1 Information about fastening, securing and arrangement

**TIP!**

Install the antenna-battery case vertically to the top and, if possible, with free view to the receiver antenna.

**TIP!**

Never cover or coat the antenna-battery case with metallic objects. Otherwise, the probe range is impaired.

**TIP!**

For optimum probe function ensure a minimum spacing of 200 mm between the probes.

## 5 Installation

### 5.2 Installing the antenna-battery case

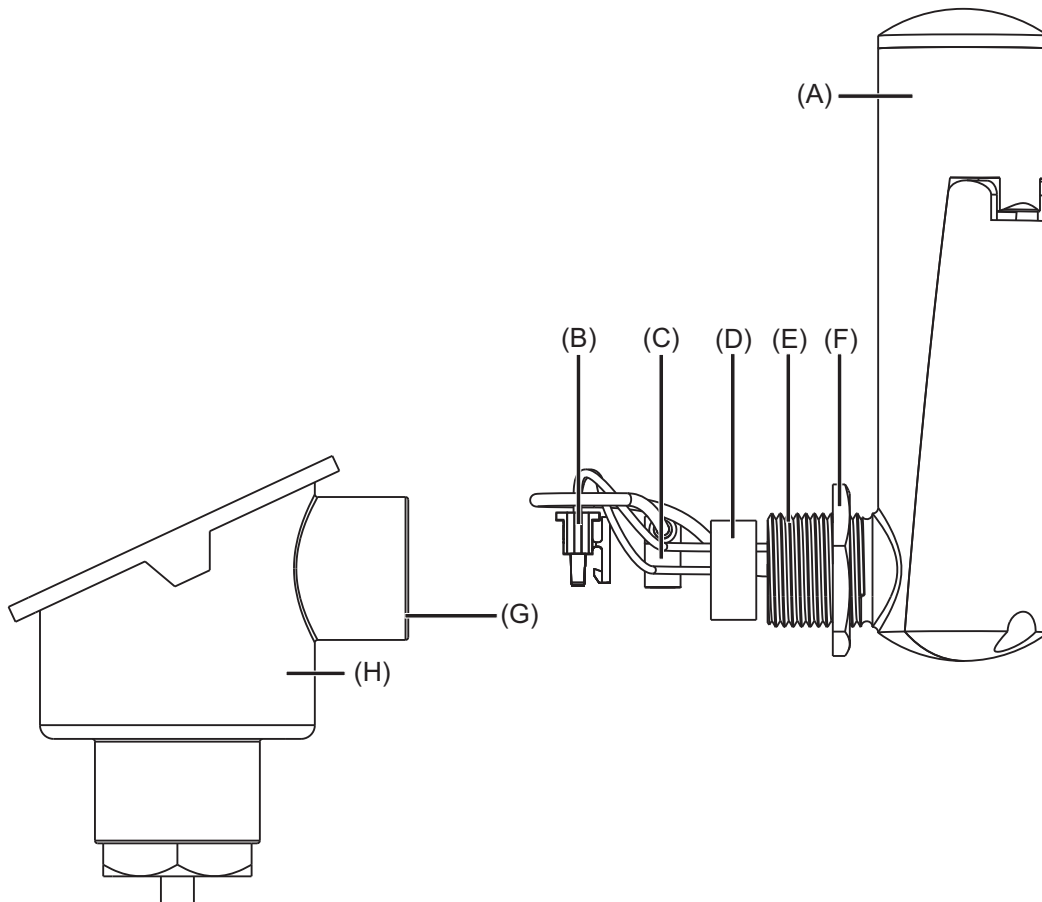

Proceed as follows to install the antenna-battery case:

Step	Activity
1	Guide the voltage supply socket (B) and SMB antenna socket (C) of the antenna-battery case (A) through the opening (G) of the connection head (H).
2	Push seal (D) into the opening (G).
3	Screw the thread (E) into the opening (G). Turn the antenna-battery case until it makes contact with the seal (D). To ensure impermeability, continue turning for at least 1/2 to max. 1 1/2 revolutions.  For an optimum transmission performance, the antenna-battery case should be positioned vertically (to the top) independent of the connection head position. Ensure that the cables also turn when the sockets (B) and (C) are turned while installing the antenna-battery case. Avoid twisting of the cables.
4	Tighten the locknut (F) and secure the antenna-battery case against loosening.

## 5.3 Installing the transmitter

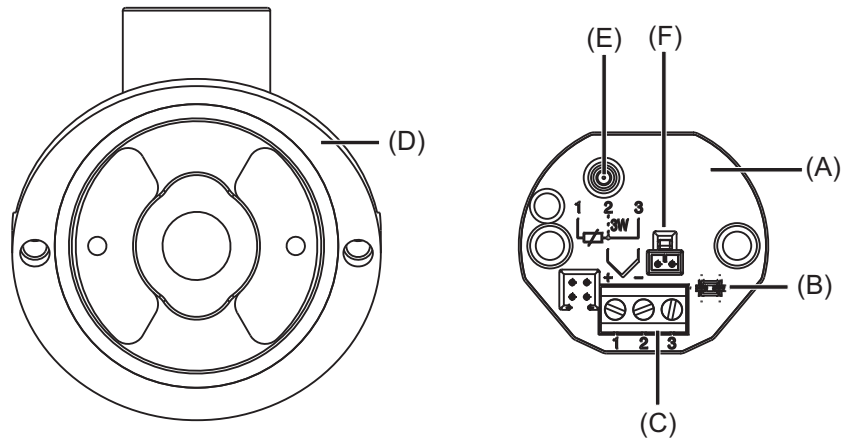

Proceed as follows to install the transmitter:

Step	Activity
1	Let all connection cables hang out of the connection head.
2	Insert the transmitter (A) into the connection head (D).
3	Fit the transmitter (A) in the connection head (D) using the screws and pressure springs (included in the delivery scope).
4	Connect the probe cables to the connector (C) as per connection diagram.
5	Guide the antenna and voltage supply connection clockwise in a large arc.
6	Connect the SMB antenna socket to the connector (E) without tensile stress.
7	Connect the voltage supply socket to the connector (F) without tensile stress.
8	Insert the antenna and voltage supply connection into the cable guide (B).
9	Fit the lid of the connection head.

# 5 Installation

## 5.4 Aligning the antenna

The recommended and unfavorable antenna alignment possibilities are shown in the following figure. The best possible reception is ensured when the recommended alignment possibilities are used.

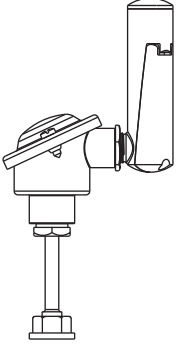
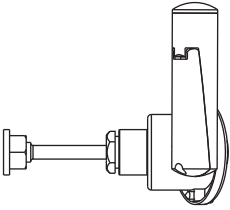
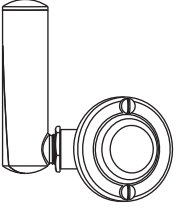
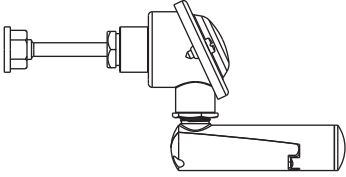
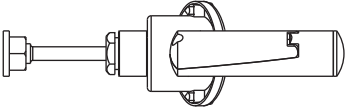
	Recommended installation: Connection head vertical and antenna-battery case vertical to the top
	Recommended installation: Connection head horizontal and antenna-battery case vertical to the top
	Recommended installation: Connection head horizontal and antenna-battery case vertical to the top
	Unfavorable installation: Never install the antenna-battery case horizontally.
	Unfavorable installation: Never install the antenna-battery case horizontally.

### 6.1 Safety information

- The electrical connection must only be carried out by qualified personnel.
- When installing and operating the transmitter ensure that no electro-static charging can take place.
- The transmitter is not suitable for installation and application in explosion endangered areas.
- Never expose the transmitter to magnetic or electrical fields (e.g. caused by transformers, walkie-talkies or electro-static discharge).
- An electrical connection deviating from the connection diagram can destroy the transmitter.

# 6 Electrical connection

## 6.2 Connection elements and connectors

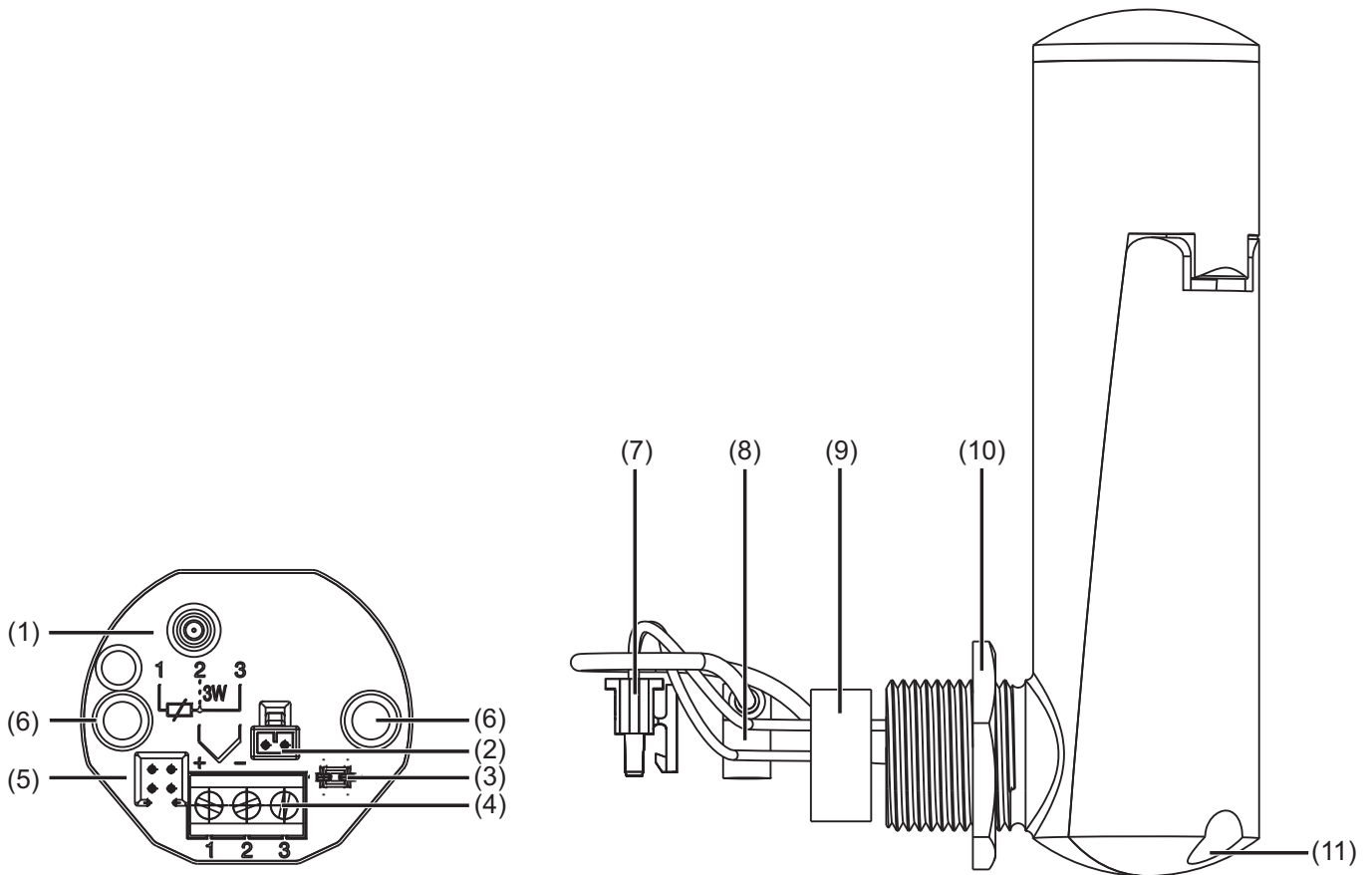

- (1) SMB antenna connector (antenna connection)
- (2) Voltage supply connector (battery connection)
- (3) Cable guide for antenna cable and voltage supply
- (4) Probe connection
- (5) Setup connector
- (6) Fastening holes for installation in the connection head, form B

- (7) Voltage supply socket (battery connection)
- (8) SMB antenna socket (antenna connection)
- (9) Seal
- (10) Locknut
- (11) Battery lid screw

## 6.3 Connection diagram

### 6.3.1 Voltage supply

Connection	Connector	Terminals	Symbol and terminal designation
Lithium battery, DC 3.6 V	2		

### 6.3.2 Analog inputs

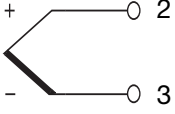
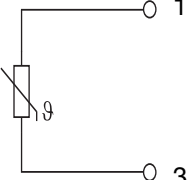
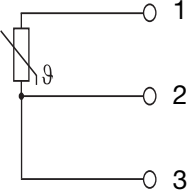
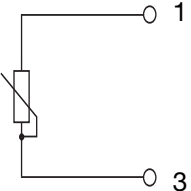
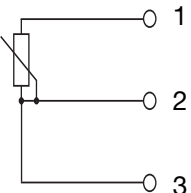
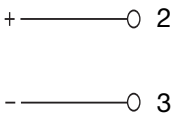
Connection	Connector	Terminals	Symbol and terminal designation
Thermocouple	4	2 and 3	
RTD temperature probe 2-wire circuit	4	1 and 3	
RTD temperature probe 3-wire circuit	4	1 to 3	
Potentiometer 2-wire circuit	4	1 and 3	
Potentiometer 3-wire circuit	4	1 to 3	
Voltage (0 ... 50 mV)	4	2 and 3	

## 6 Electrical connection

---

### 6.3.3 Output

Connection	Connector	Terminals	Symbol and terminal designation
Antenna connector	1		

### 6.3.4 Interface

Connection	Connector	Terminals	Symbol and terminal designation
Setup	5		

## 7.1 General information about the setup program

The setup program serves to configure probes and receivers by means of a PC. The configuration data can be archived on data carriers and printed.

Configurable parameters are:

- Probe ID
- Transmission interval
- Configuration of the probe used

The factory settings are:

- Probe ID consecutively
- Transmission interval (15s)
- Probe setting as per order specifications  
(Example: Pt100 in 3-wire circuit, -200 ... +600 °C)

The connection between probe and PC is established via a PC interface (USB/TTL or TTL/RS232 converter).

The screenshot shows the Wtrans software interface. The left pane displays a tree view of the configuration structure, including 'Receiver EC', 'Channels', and 'Probe'. The right pane shows the configuration for 'Channel 1'.

**Channel 1 configuration:**

- Probe ID: 113
- Limit 1: 0.000
- Limit 2: 0.000
- Hysteresis: 0.000
- Scaling start: 0.000
- Scaling end: 100.0
- Offset: 0.000 °C
- Filter time constant: 0 s
- Decimal place: xxx.x
- RF timeout: 3 Transmission intervals
- Alarm type 1: OFF
- Alarm type 2: OFF
- Time delay: 0 s
- Linearization: Linear
- Unit: Percent

Below the configuration pane is a table showing the data for the channels:

Channel	Date	Time	Probe ID	Decimal place	Value	Min.	Max.	RF channel quality	operat
1	13.9.2010	08:35:17	113	Auto decimal place	22.691 °C	0.0020 °C	35.514 °C	100 %	3.2
2	13.9.2010	08:35:17	no link	Auto decimal place	---	---	---	---	---
3	13.9.2010	08:35:17	no link	Auto decimal place	---	---	---	---	---
4	13.9.2010	08:35:17	no link	Auto decimal place	---	---	---	---	---
5	13.9.2010	08:35:17	no link	Auto decimal place	---	---	---	---	---
6	13.9.2010	08:35:17	no link	Auto decimal place	---	---	---	---	---

At the bottom of the window, it shows the connection status: 'Connected with Wtrans receiver EC - Wtrans E., Addr.:1, USB <-> Serial (LID: 00000514)' and the user name 'User: Specialist'.

# 7 Setup program

---

## 7.2 Hardware and software prerequisites

The following hardware and software prerequisites must be fulfilled for operation and the software installation:

### Minimum configuration

- Intel Pentium III<sup>1</sup> or higher
- Microsoft Windows 2000 or XP<sup>2</sup>
- 256 MB central memory
- CD drive
- Mouse
- a free USB port or
- a free serial port (depending on the interface used)
- 120 MB free hard-disk storage capacity

### Recommended configuration

- Intel Pentium 4<sup>1</sup>
- Microsoft Windows XP<sup>2</sup>
- 512 MB central memory

### Information about Windows 2000 or XP

If several users are managed on the computer, ensure that the user is logged in, who will work with the program later. Ensure that the user has administrator rights while installing the software. Once installation is completed, the rights can be restricted again.

In the event of non-observance of this information, correct and complete installation cannot be guaranteed!

---

<sup>1</sup> Intel and Pentium are registered trademarks of the Intel Corporation.

<sup>2</sup> Microsoft and Windows are registered trademarks of the Microsoft Corporation.

### 7.3 Establishing the connection between PC and probe

The connection between probe and PC is established via a PC interface TTL/RS232 converter and adapter (socket) or USB/TTL converter and adapter (socket).



**CAUTION!**

Permanent interface operation!

The PC interface TTL/RS232 converter or USB/TTL converter is only designed for a time-limited interface connection.

Please ensure that the interface connection is disconnected and the probe correctly closed once the setup data transfer is completed.



**CAUTION!**

Disconnect and remove the voltage supply!

Malfunctions can occur, if the connection between battery and transmitter is disconnected while the setup connector is still connected.

Do not disconnect the battery from the transmitter as long as the setup connector is still connected.



**CAUTION!**

Low battery!

A low battery can lead to interface problems and result in an incorrect configuration or data loss.

Please ensure that the battery used for the connection between PC and probe never reaches the "Low battery" status.

# 7 Setup program

## TTL/RS232

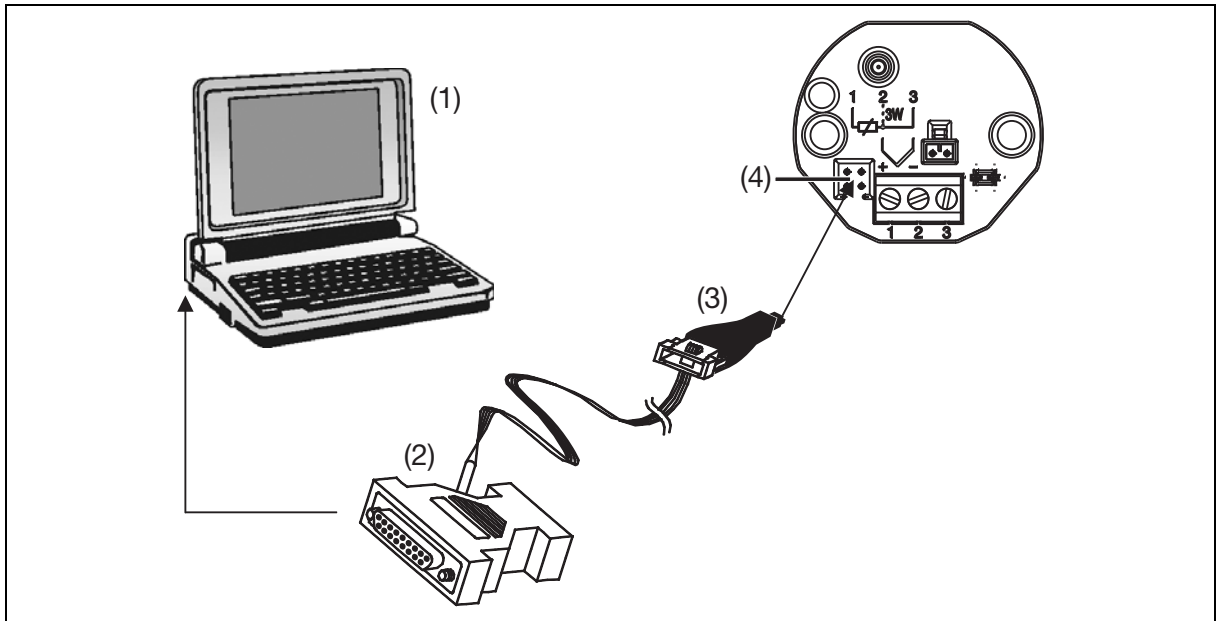

- (1) Laptop/PC  
(2) RS232 connector  
(3) Adapter socket, 4-pin  
(4) Probe interface

For the setup via the TTL/RS232 converter, establish the following connections:

Step	Activity
1	Insert the RS232 connector (2) into the laptop/PC (1).
2	Connect the adapter socket, 4-pin, (3) to the probe interface (4).



### TIP!

For probe configuration, ensure that the probe is connected to the voltage supply of the antenna-battery case.

## USB/TTL

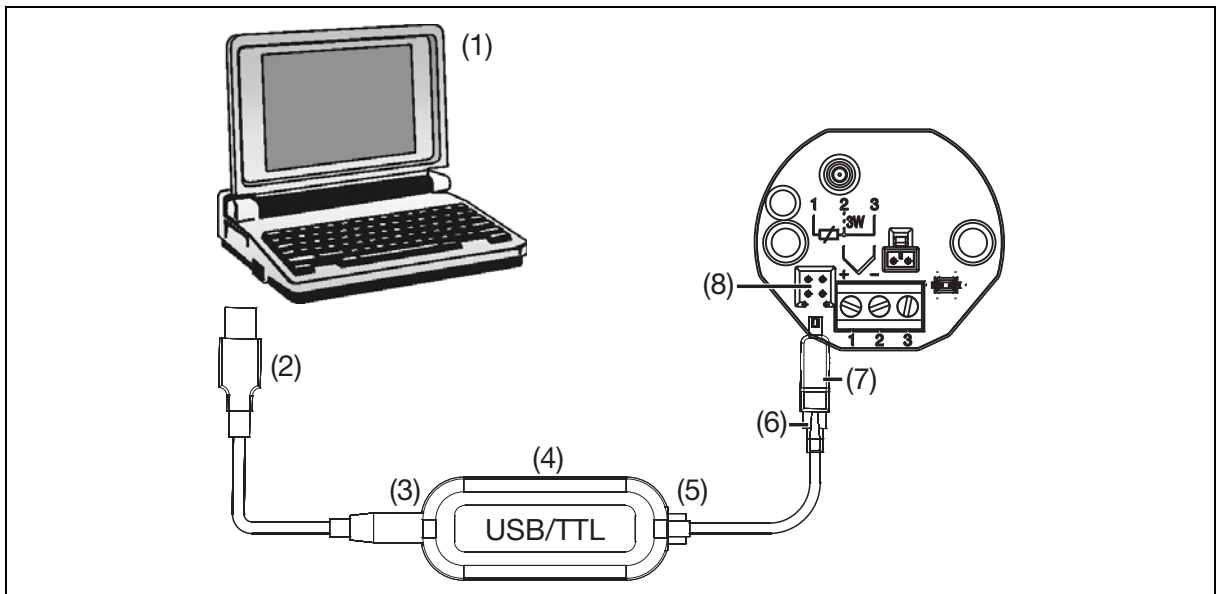

- |                       |                                  |
|-----------------------|----------------------------------|
| (1) Laptop/PC         | (5) Modular jack RJ-45           |
| (2) USB connector     | (6) Adapter of the modular cable |
| (3) USB socket        | (7) Adapter socket, 4-pin        |
| (4) USB/TTL converter | (8) Probe interface              |

For the setup via the USB/TTL converter, establish the following connections:

Step	Activity
1	Insert the USB connector (2) of the USB cable into the laptop/PC (1).
2	Insert the USB bush (3) of the USB cable into the connector of the USB/TTL converter (4).
3	Connect the RJ-45 connector (5) of the modular line to the RJ-45 socket of the USB/TTL converter (4).
4	Connect the 4-pin adapter socket (7) to the adapter of modular line (6).
5	Connect the adapter socket, 4-pin, (7) to the probe interface (8).



### TIP!

For probe configuration, ensure that the probe is connected to the voltage supply of the antenna-battery case.

# 7 Setup program

---

## 7.4 Probe configuration

This chapter explains the configuration of a probe via the setup program. Prerequisite being that the probe and the PC are connected via an interface.

### 7.4.1 Establishing the communication

A differentiation is made between two different way of proceeding when establishing the communication between probe and setup program:

- Establish the communication with "Device settings assistant".  
This is the case when the setup program is used for the first time (list of devices empty).
- Establish the communication without "Device settings assistant".  
This is the case when the receiver/probe and setup program have already communicated (list of devices with entries).

#### Establishing the communication using the assistant

How to proceed:

Step	Activity
1	Start the setup program.
2	Select the "Establish connection" function in the "Data transfer" menu. <i>The "Assistant for the device settings" appears.</i>
3	Select the probe under the "Device version" and confirm by pressing "Continue".
4	Confirm the PC communication interface "Serial interface" by pressing "Continue".
5	Select the serial interface (e.g. COM1) and confirm with "Continue".
6	Confirm the MU protocol (transmitter) by pressing "Continue".
7	Exit the assistant by pressing "Finish". <i>The device list with the selected probe appears.</i>
8	Click on the "Connect" button. <i>The device list is closed, the assistant terminated and the communication between probe and setup program established.</i>

## Establishing the communication without using the assistant

How to proceed:

Step	Activity
1	Start the setup program.
2	Select the "Establish connection" function in the "Data transfer" menu. <i>The device list containing all devices entered is mapped in.</i>
3	Select the desired probe by clicking with the left mouse key.
4	Click on the "Connect" button. <i>The device list is closed, the assistant terminated and the communication between probe and setup program established.</i>

## 7.4.2 Reading the current probe parameters

How to proceed:

Step	Activity
1	In the "File" menu select the "New" function. <i>The "Device assistant" starts.</i>
2	Confirm the "User-defined setting" by pressing the "Continue" button.
3	Select the "Frequency band" and confirm with "Continue".
4	Select the receiver variant and confirm by pressing "Continue".
5	Exit the overview of the selected settings by pressing "Finish". <i>The current settings are displayed in the setup program.</i>
6	Select the desired probe from the navigation tree by clicking with the left mouse key.
7	In the "Data transfer" menu select the "Data transfer from device" function.
8	Exit the inquiry "Save file" by selecting "Skip". The current probe parameters are downloaded to the setup program.

## 7.4.3 Editing probe parameters

How to proceed:

Step	Activity
1	Select the probe to be edited from the navigation tree by double clicking with the left mouse key. <i>The "Probe configuration" is opened.</i>
2	Edit the desired parameters.
3	Confirm editing with "OK".
4	Save the parameters in the "File" menu with the "Save" function.

## 7 Setup program

---

### 7.4.4 Transmitting new parameters to the probe

How to proceed:

Step	Activity
1	In the "Data transfer" menu select the "Data transfer to device" function. <i>The current parameters are transmitted to the probe</i>
2	Finish the communication between setup program and probe in the "Data transfer" menu using the "Disconnect connection" function.

## 7.5 ParametersOverview

Parameters	Factory setting	Value range/Selection	
Probe ID	inactive	1 ... 99999	
Transmission interval	15 s	1 ... 3600 s	
Transmission frequency	868.4 MHz	868.4 MHz Display only, cannot be edited!	
Probe type	RTD temperature probe	Potentiometer, voltage, thermocouple, <b>RTD temperature probe</b>	
Sensor	Pt100	depending on the probe type, <b>Pt100 DIN EN 60751 -200 ... +600 °C</b>	
Connection type	3-wire circuit	<b>3-wire circuit</b> , 2-wire circuit	
Lead resistance	0 Ohm	0 ... 22 Ohm Only with 2-wire circuit!	
Resistance RP	10000 Ohm	5 ... <b>10000</b> Ohm Only for potentiometer probe type!	
Resistance R0	0 Ohm	0 ... 4000 Ohm Only for potentiometer probe type!	
TAG number		10-digit number, freely selectable	
Information text		10-digit number, freely selectable	
Installation date	current date	any date	



### TIP!

At a transmission interval of > 15 s, the probe transmits a so-called link telegram (after a set-up transmission), i. e. the telegrams are transmitted at the factory-set interval of 15 s for a period of 30 minutes, and only then at the set transmission interval.



### TIP!

Once the setup connector is connected, the probe automatically transmits telegrams at a transmission interval of 1s to ensure that changes can be immediately detected by the receiver. After the setup connector is removed, the telegrams are transmitted again at the set transmission interval.

# 7 Setup program

---

## Term definition

### Probe ID

The probe ID is an unmistakable ID with max. 5 characters which is recognized by the receiver. The ID can be individually changed, for example, to achieve a better overview of a system. Ensure that an ID is not used simultaneously by two probes within the reception range to avoid malfunctions.

### Transmission interval

This parameter is used to define the time intervals used to transmit data to a receiver. The setting of the "Transmission interval" parameter affects the battery service life. For this reason, act with caution and do not only consider the transmission quality when selecting the interval.

### Transmission frequency

The transmission frequency defines the frequency band used to transmit data to a receiver. The transmission frequency is defined at 868.4 MHz for Europe because special regulations are defined concerning transmission interval and transmission capacity for the ISM band (Industrial, Scientific and Medical Band).

## 8.1 Technical data

### 8.1.1 Analog inputs

#### Thermocouples

Designation	Standard	Measuring range	Measuring accuracy
Fe-CuNi „L“	DIN 43710	-200 to +900 °C	± 0.1 %
Fe-CuNi „J“	DIN EN 60584	-210 to +1200 °C	± 0.1 % from -100 °C
Cu-CuNi „U“	DIN 43710	-200 to +600 °C	± 0.1 % from -100 °C
Cu-CuNi T	DIN EN 60584	-270 to +400 °C	± 0.1 % from -150 °C
NiCr-Ni K	DIN EN 60584	-270 to +1372 °C	± 0.1 % from -80 °C
NiCr-CuNi „E“	DIN EN 60584	-270 to +1000 °C	± 0.1 % from -80 °C
NiCrSi-NiSi „N“	DIN EN 60584	-270 to +1300 °C	± 0.1 % from -80 °C
Pt10Rh-Pt „S“	DIN EN 60584	-50 to +1768 °C	± 0.15 % from 20 °C
Pt13Rh-Pt „R“	DIN EN 60584	-50 to +1768 °C	± 0.15 % from 50 °C
Pt30Rh-Pt6Rh „B“	DIN EN 60584	0 to 1820 °C	± 0.15 % from 400 °C
W5Re-W26Re „C“		0 to 2320 °C	± 0.15 %
W3Re-W25Re „D“		0 to 2495 °C	± 0.25 %
W3Re-W26Re		0 to 2400 °C	± 0.15 %
Chromel-Copel		-200 to +800 °C	± 0.1 % from -80 °C
Chromel-Alumel		-200 to +1372 °C	± 0.1 % from -80 °C
PLII (Platinel II)		0 to 1395 °C	± 0.15 %
MoRe5-MoRe41		0 to 2000 °C	± 0.2 %
Cold junction		Pt1000 internal	
Cold junction accuracy		± 1 K	

#### RTD temperature probe

Designation	Standard	Measuring range	Measuring accuracy
Pt100 (TK value = $3.85 \times 10^{-3}$ 1/K)	DIN EN 60751	-100 to +200 °C -200 to +600 °C	± 0.1 K ± 0.2 K
Pt500 (TK value = $3.85 \times 10^{-3}$ 1/K)	DIN EN 60751	-100 to +200 °C -200 to +600 °C	± 0.1 K ± 0.2 K
Pt1000 (TK value = $3.85 \times 10^{-3}$ 1/K)	DIN EN 60751	-100 to +200 °C -200 to +600 °C	± 0.1 K ± 0.2 K
Ni 100 (TK value = $6.18 \times 10^{-3}$ 1/K)	DIN 43760	-60 to +250 °C	± 0.2 K

## 8 Supplement

Designation	Standard	Measuring range	Measuring accuracy
Ni 500 (TK value = $6.18 \times 10^{-3}$ 1/K)	DIN 43760	-60 to +150 °C	± 0.2 K
Ni 1000 (TK value = $6.18 \times 10^{-3}$ 1/K)	DIN 43760	-60 to +150 °C	± 0.2 K
Pt100 (TK value = $3.917 \times 10^{-3}$ 1/K)	JIS 1604	-100 to +200 °C -200 to +600 °C	± 0.1 K ± 0.2 K
Pt50 (TK value = $3.91 \times 10^{-3}$ 1/K)	ST RGW 1057 1985	-200 to +600 °C	± 0.2 K
Pt100 (TK value = $3.91 \times 10^{-3}$ 1/K)	GOST 6651- 94 A.1	-100 to +200 °C -200 to +600 °C	± 0.1 K ± 0.2 K
Cu50 (TK value = $4.26 \times 10^{-3}$ 1/K)	GOST 6651- 94 A.4	-50 to +200 °C	± 0.2 K
Cu100 (TK value = $4.26 \times 10^{-3}$ 1/K)	GOST 6651- 94 A.4	-50 to +200 °C	± 0.2 K
Connection type	2-wire or 3-wire circuit		
Sensor lead resistance			
2-wire circuit	Measuring resistance + ≤ 22 Ω total line resistance		
3-wire circuit	11 Ω per line		
Probe current	< 0.5 mA		
Lead compensation	Not required for 3-wire circuit (max. admissible 11 Ω per line). Can be configured on the probe with 2-wire circuit (≤ 22 Ω).		

### Potentiometer

Designation	Measuring range	Measuring accuracy
Potentiometer	< 400 Ω ≥ 400 Ω to ≤ 4000 Ω > 4000 Ω to ≤ 10000 Ω	± 400 mΩ ± 4 Ω ± 10 Ω
Connection type	2-wire or 3-wire circuit	
Sensor lead resistance		
2-wire circuit	≤ 22 Ω	
3-wire circuit	≤ 11 Ω per line	

### Voltage

Designation	Measuring range	Measuring accuracy
Voltage	0 to 50 mV	± 0.1 %

### 8.1.2 Output (radio transmission)

Probe ID	max. 5-digit ID, factory-set, can be configured customer-specific
Transmission interval	adjustable from 1 to 3600 s (ex-factory 15 s)
Transmission frequency	ISM band 868.4 MHz (Europe)
Transmission capacity	+10 dBm
Open air range	Max. 300 m when using the antenna wall holder of the receiver and 3 m long antenna cable. When installing the antenna directly onto the receiver, a reduced range of approx. 40% must be taken into account.
Output signal	
Thermocouple	Voltage (mV)
RTD temperature probe	Resistance ( $\Omega$ )
Potentiometer	Percent (%) and resistance ( $\Omega$ )
Voltage	Voltage (mV)
Configuration	with setup program
Configurable parameters	Probe ID (max. 5-digit ID) and transmission interval

### 8.1.3 Electrical data

Voltage supply	
Lithium battery	Rated voltage: 3.6 V, rated capacity: 2.2 Ah
Size	AA
Operating life	approx. 1 year with the factory-set values (transmission interval = 15s) and at room temperature (fast transmission interval and high or low ambient temperature reduce the battery operating life)
Battery change	only use the lithium battery available as accessories

## 8 Supplement

### 8.1.4 Environmental influences

#### Transmitter in the B head with antenna-battery case

Ambient temperature range	-30 ... +85 °C
Storage temperature range / storage humidity	-40 ... +85 °C / rel. humidity ≤ 95 %
Temperature coefficient <sup>a</sup>	
Thermocouple	≤ ± 0.005 % / K deviation 22 °C plus accuracy of the cold junction
RTD temperature probe	≤ ± 0.005 % / K deviation from 22 °C
Potentiometer	≤ ± 0.01 % / K deviation from 22 °C
Voltage	≤ ± 0.005 % / K deviation from 22 °C
Climate class	10 cycles at 10 °C / 80 °C, as per IEC 68-2-30, rel. humidity 95 %, during operation
Vibration resistant	as per GL characteristic line 2
Admissible mechanical shock resistance	10 g / 6 ms, as per DIN IEC 68-2.29
Electromagnetic compatibility (EMC)	as per DIN EN 61326-1
Interference emission	Class B
Interference immunity	Industrial requirements
Radio frequency spectrum	ETSI EN 300 220-1 (V 2.3.1) and ETSI EN 300 220-2 (V 2.3.1)

<sup>a</sup> All accuracy values in % refer to the maximum measuring range.

### 8.1.5 Case

#### Transmitter

Type	Plastic case to be installed in connection head, form B
Material	Polycarbonate
Flammability class	UL 94 V2
Dimensions	
Diameter	44 mm
Height with/without connectors	31 mm / 27 mm
Protection type	IP65, when installed (with suitable head, form B)
Connections	
Sensor	3-pole connection terminal RM 5 mm, conductor cross-section 1.5 mm <sup>2</sup>
Antenna	SMB connector
Voltage supply	2-pole multi-pin connector RM 2.54 mm
Setup	4-pin connector
Weight	approx. 35 g

### Antenna-battery case

Type	Plastic case with M20x1.5 thread for connection head, form B
Material	Polyetherimide
Flammability class	UL 94 HB or UL 94 V-0
Dimensions	
Diameter	30 mm
Height	115 mm
Protection type	IP65, as per DIN EN 60529
Connection	
Antenna	SMB inlet, 50 $\Omega$
Battery connection	2-pole connector RM 2.54 mm
Operating position	preferably vertical (optimum alignment to the receiver antenna)
Weight (including battery)	approx. 80 g







**JUMO GmbH & Co. KG**

Street address:

Moritz-Juchheim-Straße 1  
36039 Fulda, Germany

Delivery address:

Mackenrodtstraße 14  
36039 Fulda, Germany

Postal address:

36035 Fulda, Germany

Phone: +49 661 6003-0

Fax: +49 661 6003-607

e-mail: [mail@jumo.net](mailto:mail@jumo.net)

Internet: [www.jumo.net](http://www.jumo.net)

**JUMO Instrument Co. Ltd.**

JUMO House

Temple Bank, Riverway  
Harlow, Essex CM20 2DY, UK

Phone: +44 1279 635533

Fax: +44 1279 635262

e-mail: [sales@jumo.co.uk](mailto:sales@jumo.co.uk)

Internet: [www.jumo.co.uk](http://www.jumo.co.uk)

**JUMO Process Control, Inc.**

8 Technology Boulevard  
Canastota, NY 13032, USA

Phone: 315-697-JUMO  
1-800-554-JUMO

Fax: 315-697-5867

e-mail: [info@jumo.us](mailto:info@jumo.us)

Internet: [www.jumo.us](http://www.jumo.us)

