



Digital Temperature Controller

DAE SUNG E.N.G  
FOX-301SERIES

www.foxeng.co.kr

## Operating Manual



Thank you very much for selecting our products.

### 1 Caution for your safety

Please read this instruction carefully before using this controller  
\* The manual's information & specification can changeable to improve its quality without any notification.

#### ⚠ Safety

1. Pls use this item after installing the duplex safety device in which is applied at dangerous factors such as serious human injury or serious damages of property & important machine because this item is not designed as safety device
2. Do not checking or repairing when it is power on
3. Please check the terminal number before connecting power supply
4. Do not disassembling or opening, remodeling, repairing without any permission

#### ⚠ Safety Instruction and Hazard Warnings

- Please read the operating manual through completely before putting the device into operation.
- We will not assume any responsibility for damage to assets or persons caused by improper handling or failure to observe the safety instructions or hazard warnings.
- For safety and licensing reasons, unauthorized conversion and/or modification of the device is not permitted.
- Do not exceed the maximum permissible current - in case of higher loads, use a contactor of adequate power. Make sure that the supplied voltage matches the values specified for the instrument.
- The device must be adequately protected from water and dust as per the application and must be accessible via the use of appropriate tools
- The device must not be exposed to extreme temperature, sunlight, strong vibrations or high levels of humidity.
- Operation or installation is not permitted under unfavorable ambient conditions such as wetness or excessive induction loads or solenoid and dust, combustible gases, vapors or solvents, especially high-frequency noise
- Avoid operation or installation close to high-frequency fields such as welding devices, sewing machines, wireless transmitter, radio systems, SCR controller, etc
- Do not install the sensor cable nearby signal cable, power cable, load cable
- Please use the shield cable when the sensor cable's lengthen, however do not make it too much longer
- Please use the sensor cable without any cutting or flaw, blemish.
- The device is not a toy and should be kept away from children
- Installation work must only be carried out by suitably qualified personnel who are familiar with the hazards involved and with the relevant regulations.
- You shouldn't tinker with anything or the product may not be opened or disassembled unless you know what you're doing. Please ask us about this questioning

#### ⚠ Danger

Attention ! Never work on electrical connections when the machine is switched on

### 2 composition

model	sensor	temp./humi.range	external size	function
FOX-301A	NTC 10K DS4000	-55.0 ~ 99.9°C 0 ~ 100%	W72 X H72mm	temp. control humi. control
FOX-301AR	NTC 10K DS4000	-55.0 ~ 99.9°C 0 ~ 100%	W72 X H72mm	temp. control humi. control RS485 communication
FOX-301JB	NTC 10K DS4000	-55 ~ 99.9°C 0 ~ 100%	W255 X H270mm	temp. control humi. control
FOX-301JR	NTC 10K DS4000	-55 ~ 99.9°C 0 ~ 100%	W255 X H270mm	temp. control humi. control RS485 communication
FOX-8301	NTC 10K DS4000	-55.0 ~ 99.9°C 0 ~ 100%	W94 X H150mm	temp. control humi. control
FOX-8301R	NTC 10K DS4000	-55.0 ~ 99.9°C 0 ~ 100%	W94 X H150mm	temp. control humi. control RS485 communication

### 3 Part name

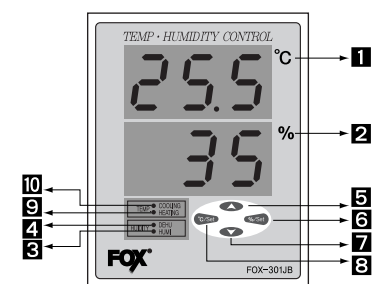
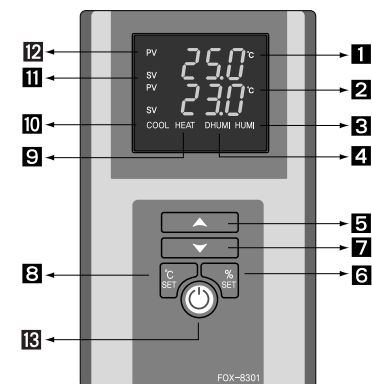
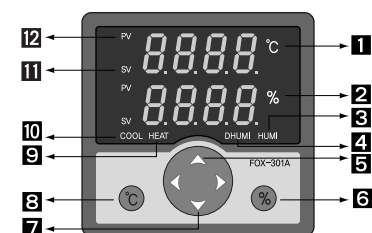

- 1: Display of the present temperature (red color)
- 2: Display of the present humidity (green color)
- 3: Output display of the humidity's working
- 4: Output display of the dehumidity's working
- 5: Up
- 6: Humidity mode
- 7: Down
- 8: Temperature mode
- 9: Display of the heating output
- 10: Display of the cooling output
- 11: Display of the measuring value
- 12: Display of the set value
- 13: Power supply

### 4 Connection

output : 250VAC 2A  
Please make use of the power relay or a suitable magnet surely.

#### ▶ FOX - 301A/AR

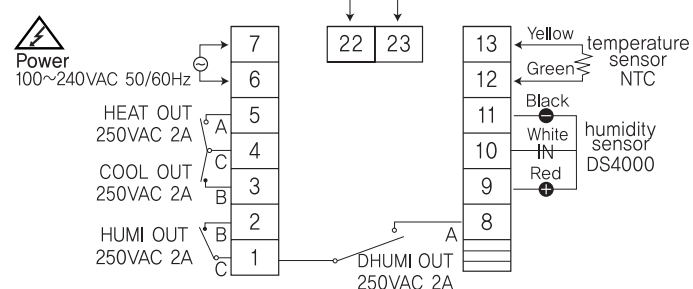

#### ▶ FOX - 301JB/JR

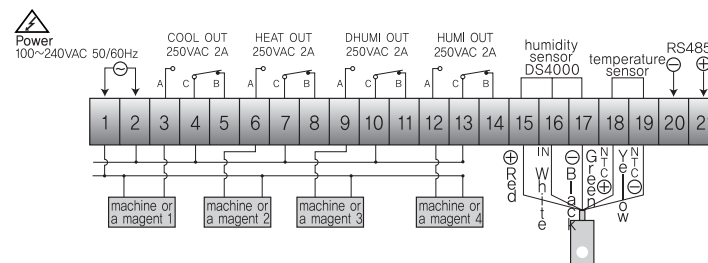

#### ▶ FOX -8301/R

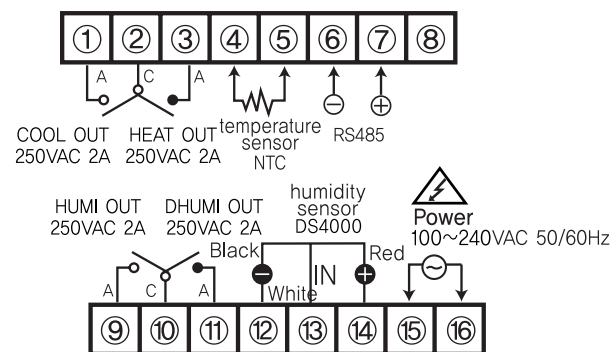

### 5 Size & Dimension

#### ▶ FOX -301A/AR( 72x72x110mm)

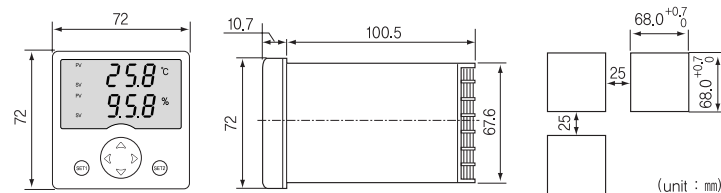

#### ▶ FOX -301JB/JR(225x270x50mm)

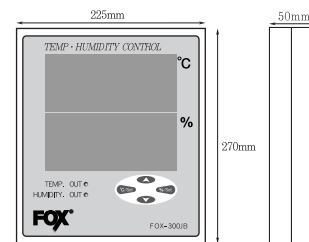

#### ▶ FOX -8301/R( 94x150x39mm)

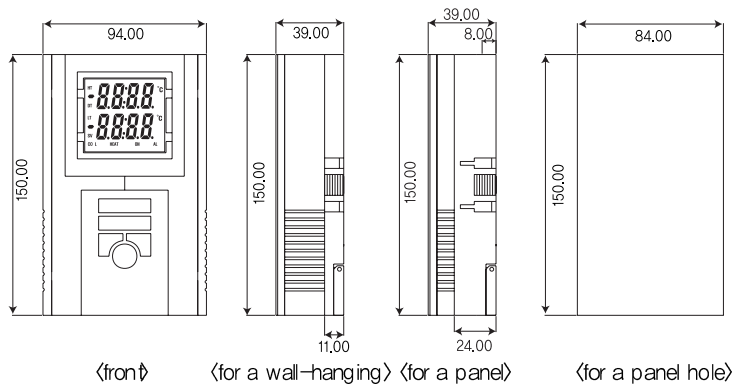

### 6 Temperature

#### Setting for the temperature

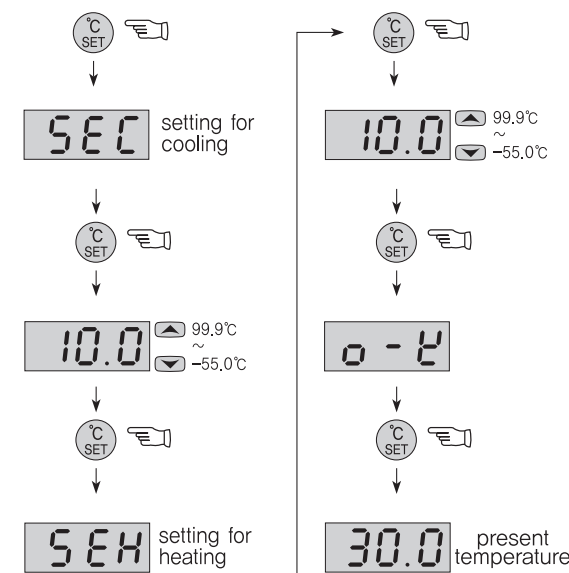

#### Setting for temperature programs

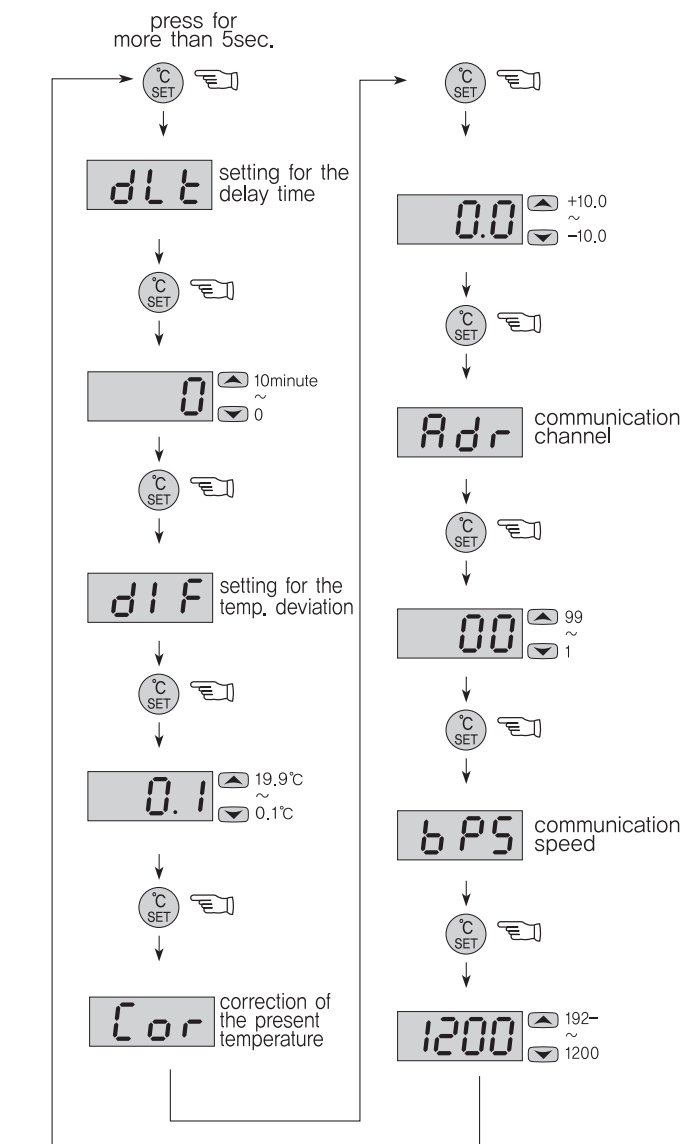

## 7 Humidity

### Setting for the humidity

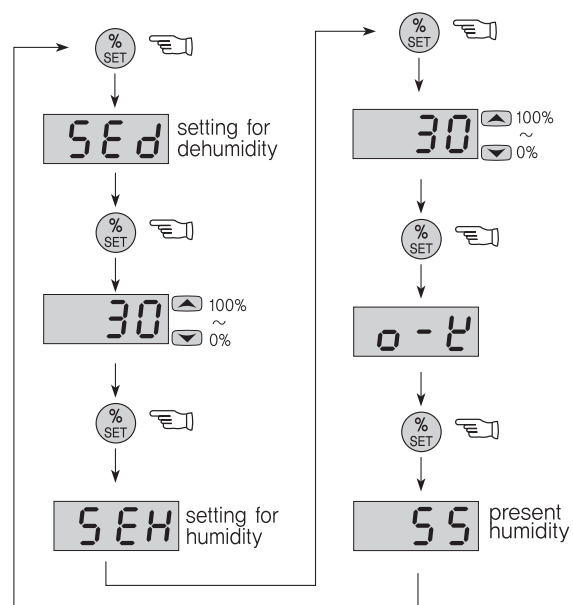

### Setting for humidity programs

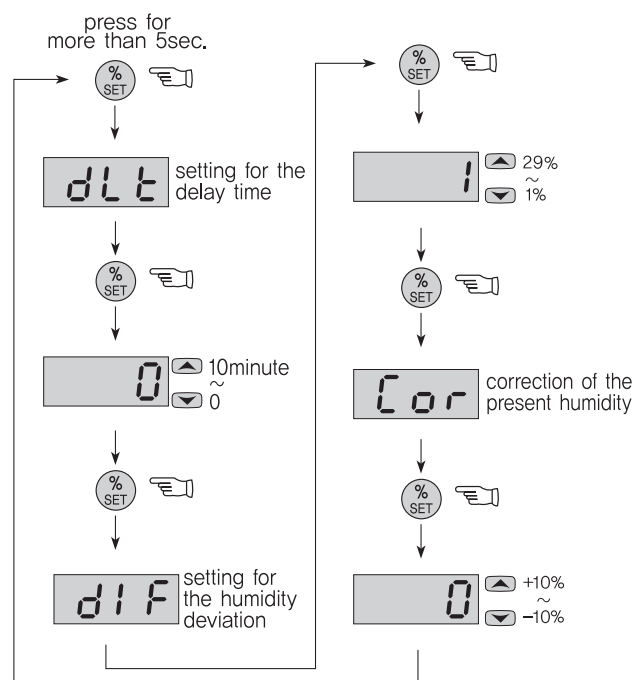

\*To change it with program mode, press the --key for more than 5 second in the present temperature display mode.

\*The set or programming mode is terminated, if you press the 0-2 key, parameters(set values) are saved after the display shows OK letter or return to present temperature automatically after 3 second.

## 8 Detailed manual

### 1. dIF : Setting for temperature deviation

- In the ON/OFF control, it needs at regular interval between ON and OFF.
- By operating the ON/OFF control frequently, the relay or its output contact can be damaged quickly and it also occurs the hunting(oscillating, chattering) by virtue of external noise. You can make use of the temperature deviation in order to protect its relay or contact and so on.

ex=> The method of the temp. deviation when ON/OFF control

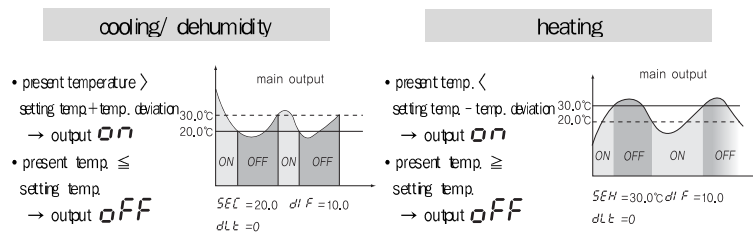

### 2. dLl : Delay time of the output

It is widely used as the followings

- in case of operating the ON/OFF control very often,
- to protect the operation machinery when re-input of the power supply or momentary stoppage of power supply

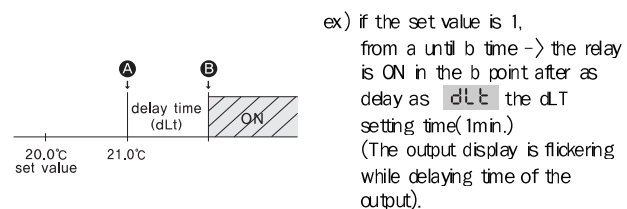

ex) if the set value is 1, from a until b time -> the relay is ON in the b point after as delay as dLl the dLl setting time(1min.) (The output display is flickering while delaying time of the output).

### 3. Cor : Correction of the present temperature.

- It is used for the correction of an discrepancy between the display temperature and real temperature

off) real temp. : 10.0°C  
display : 12.0°C → Cor : 0.0 ⇒ -2.0 correction  
→ 10.0°C display

### 4. Rdr : Communication channel

- To designate the channel while RS485 communication working

### 5. bPS : Communication speed(velocity)

- 120, 1200 : 1200bps
- 240, 2400 : 2400bps
- 480, 4800 : 4800bps
- 960, 9600 : 9600bps
- 192, 1920 : 19200bps

(Start bit 1, Stop bit 1, Non parity)

## 9 Temp.range & set value when deliver

	function	display	range	set values when deliver	remarks
setting Temp.	setting for cooling	5CH	-55.0~99.9	10.0	
	setting for heating	5EH	-55.0~99.9	10.0	
setting programs	temperature deviation	dIF	0.1~19.9	1.0	
	delay time	dLl	0~10	0	minute
	correction of the temperature	Cor	-10.0~10.0	0.0	correct for an discrepancy between the display temp. and an actual temperature.
	Communication channel	Rdr	01~99	0	RS485communication
	Communication speed	bPS	1200/2400/4800/9600/19200	1200	RS485 communication

## 10 Humi. range & set value when deliver

	function	display	range	set values when deliver	remarks
setting humi.	setting for dehumidify	5Ed	0~100%	30%	
	setting for humidity	5EH	0~100%	30%	
setting programs	humidity deviation	dIF	1~29	1	
	delay time	dLl	0~10	0	minute
	correction of the humidity.	Cor	-10~10	0	corrected for an discrepancy between the display humi. and an actual humidity.

## 11 Communication output

### Interface

specification	in conformity EIA RS485
maximum connection	32(However, available to set the Address from 01 until 99)
the method of communication	two-wire half-duplex operation
synchronous system	asynchronous system
communication distance	within 1.2km
communication speed	1200/2400/4800/9600/19200bps(possible to selection)
Start bit	fixed 1bit
Stop bit	fixed 1bit
Parity bit	none
Data bit	fixed 8bit
Protocol	BCC

### System

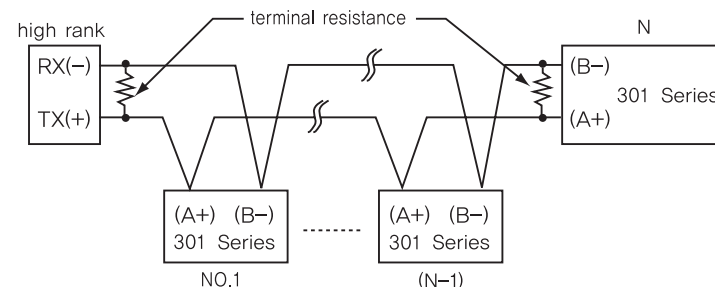

### Definition between communication command and Block

Show the Format of the Command

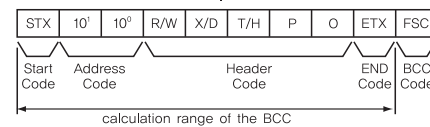

Show the Format of the Response

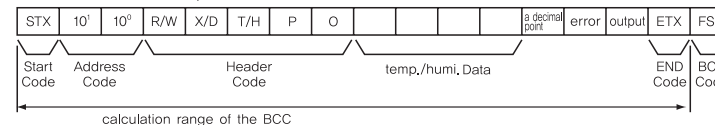

- Start Code  
show the lead(head) of the Block  
ACK will be added in case of STX->[02H], Response
- Address Code  
A high rank system can discriminates the channel code number among FOX-301series  
It is available to set between 01 and 99(BCD ASC II)
- Header Code  
show the command name as a alphabetic letter  
RX(reading demand) → R[52H], X[58H]  
RD(reading response) → R[52H], D[44H]  
WX(writing demand) → W[57H], X[58H]

WD(writing response) → W[57H], D[44H]  
TPO(temperature measuring value) → W[54H], P[50], O[30H]  
HPO(temperature measuring value) → H[48H], P[50], O[30H]

- Composition of Data  
Data is displayed as "Hexadecimal"
- Decimal point → O[30H] there is no "decimal point"  
1[31H] there is "decimal point"
- Error → O[30H] there is no "error"  
2[32] short-circuited error of the sensor  
1[31] interrupted of the sensor's cable
- Output → O[30H] COOL/HEAT OUT ON  
HEAT/DHUMI OUT ON  
1[31H] COOL/HEAT OUT ON  
HEAT/DHUMI OUT OFF  
2[32H] COOL/HEAT OUT OFF  
HEAT/DHUMI OUT ON  
3[33H] COOL/HEAT OUT OFF  
HEAT/DHUMI OUT OFF
- END Code  
show the end(close) of the Block ETX → [03H]
- BCC  
show the XOR arithmetic and logic values from the start(STX) to the ETX
- the others : As of no response of the ACK
  - in case of not equivalent to the channel after receiving STX
  - in case of generating the Receive Buffer Overflow
  - in case of not equivalent to the communication's set values or baud rate
- treatment- in case of no response of the ACK
  - check the cable
  - check the communication's condition (set values)
  - if the main cause of the status is the noise, try to do communication practicing 3times until recovering normally.
  - change the communication speed in case of bring about the communication's error frequently.

## 12 Error message

- E r I** Memory error. Turn the power off and turn it on again  
If the error message persists, please request us A/S by return
- o - E** Sensor error. The sensor is interrupted. Check the cable.
- S - E** Sensor error. The sensor is short-circuited. Check the cable

\*The product's specification can be changed without any notification to improve its quality.

■H. Office : B-112, Techno plaza 681-11 Junpo 1 dong, Busanjin-ku, Busan, Korea  
Factory : B-408,409,410 Techno plaza 681-11 Junpo 1 dong, Busanjin-ku, Busan, Korea  
A/S TEL : +82-51-819-0426 FAX : 82-51-819-4562  
E - mail : foxeng@foxeng.co.kr  
Homepage : http://www.foxeng.co.kr

\*This device works proper operation with;  
Surrounding Temp. : 0°C~60°C  
Surrounding Humi. : below 80%RH  
Regular power : 220VAC±10% 50/60Hz

■ Main products & Development  
- Digital temperature controller  
- Digital humidity controller  
- Digital timer