

Assembly instruction / User manual

1-Q motor speed control unit digital, type DLS 24/xx-460



Technical data under reserve technical changes

Please read these instruction before using and please keep safe for future.
You may download further technical advice under www.eph-elektronik.de.

Table of contents

1.	Safety Instructions and Safeguarding	3
1.1.	Installation note.....	3
1.2.	ESD-Protection / Hazard note.....	3
2.	Getting started DLS24/xx-460 with 6/4-pole spring clamp terminal.....	4
3.	Technical features.....	5
4.	Technical data.....	5
5.	Connecting.....	6
5.1.	Control connection.....	7
5.2.	Connecting diagram.....	7
6.	CE Declaration of Conformity.....	8

1. Safety Instructions and Safeguarding

1.1. Installation note

An external mains adapter is required for the electrical supply of the controller EPH 460. If this mains adapter is itself supplied with a voltage >50V DC or >75V AC the following points have to be considered:

The unit should only be installed by qualified specialist personnel. Installation and operation of the unit should comply with the local regulations for electrical installations as well as health and safety regulations. The protection of people and property must be warranted by applying the currently applicable safety regulations (VDE, electrical safety regulations, IEC, etc.). High start-up currents can occur at the moment of tuning on a controller device / mains adapter due to charging process of the intermediate circuit. An effective safeguard is therefore required on the mains input side (e.g. a C-Rated 16A line circuit breaker). The use of RCD circuit breakers before control unit / mains adapter is not recommended because of the leakage currents generated by EMC interference suppressing devices. The regulator card / mains adapter must not be operated without an effective connection to earth! The connection to earth must comply with local regulations.

1.2. ESD-Protection / Hazard note

Attention during installation of the electronic board!	Danger to burn - Beware!	Danger to fire- Beware!	Danger to life-Beware!
<p>It must be warranted on your part that there is sufficient ESD-protection.</p> 	<p>Parts of this controller card can be reach a temperature up to 80°C. Increased risk at controller cards without protective cover.</p>	<p>Unprofessional handling and installation can cause a fire.</p>	<p>Parts of this controller card are under intermediate circuit voltage and remain energised >50VAC respectively 75VDC after turning main power off. Coming into contact with the terminals, lines and unit parts can cause serious injuries or result in death!</p>

2. Getting started DLS24/xx-460 with 6/4-pole screw terminal block

1. Select modes:

- put jumper 1 on 1-2 for internal speed reference (potentiometer 1) or on 2-3 for external speed reference.
- put jumper 2 on 1-2 for 12V motor or on 2-3 for 24V motor.
- put jumper 3 on 1-2 for speed reference max. 5V or on 2-3 for 10V target value input.
- put jumper 4 on 1-2 for internal controller enable or 2-3 for external controller enable (terminal 4).

2. Turn potentiometer 2 (I_{max}) for current limitation to right position.

3. Turn potentiometer 3 (I_{xR}) compensation to left position.

4. Connection of the control wires see connection diagram, page 7.

5. Connect DC motor to terminals 7 and 8.

6. Connect power supply: to terminal 9 GND, to terminal 10 plus (approx. 12 – 36 V DC).

7. Now turn on power supply.

8. LED green (power on) illuminates on the pcb.

9. With potentiometer 1 (n ref) the speed reference can be adjust from 0 to 100%, if jumper 1 is put on 1-2.

5. Connecting

5.1. Control connections

Speed reference value: Terminal 1: GND
Terminal 2: wiper external potentiometer (10kOhm)
Terminal 3: 5V DC

Controller enable (RF): Terminal 4: Input 10-36V DC H/active

U_{E2}: Terminal 5: Output (12-36V DC, <50mA) e.g. for
external switch for controller enable

Ready for operation (BTB): Terminal 6: digital output (12-36V DC, <50mA)

5.2. Connecting diagram

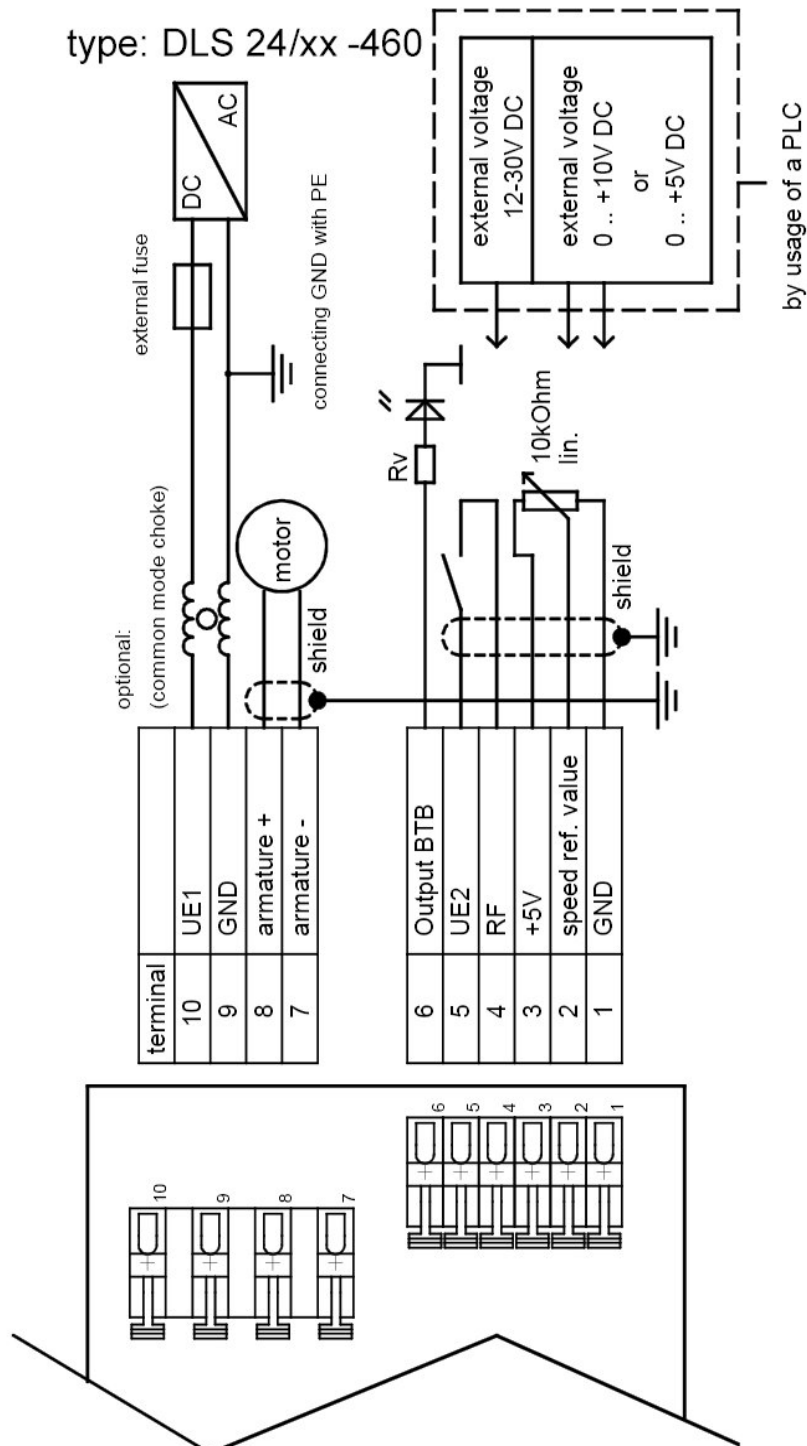

6. CE Declaration of Conformity

The manufacturer

EPH elektronik Produktions- und Handelsgesellschaft mbH
Rudolf-Diesel-Straße 18
DE-74354 Besigheim-Ottmarsheim
Tel.: +49(0)7143/81 52 - 0

herewith declares that the product:

Product:	1-Q Transistor Controller digital
Type	DLS 24/10/x – 460 DLS 24/20/x – 460

is conform to the mentioned EC-regulation in connection with the test peripheral devices:

Regulation 2014/30/EU – EMC-directive

The following harmonised standards are applied:

DIN EN 61000-6-4:2007 +A1:2011	EMI emission
DIN EN 61000-6-2 VDE 0839-6-2:2006-03	EMI immunity

The transistor controller`s conformity to the mentioned standards doesn` t concern for the complete system. An extra EMC-test would be necessary to get the conformity for the complete system.

If the transistor controller is integrated in a machine, the machine has to comply with regulation 2006/42/EG (machines directive). If not, operating is not allowed.
If the supply voltage of the machine is > 50V AC respectively 75V DC, the regulation 2014/35/EC (low voltage directive) is to be observed.

Name authorised person:	Reiner Mannsperger
Address authorised person:	see address of the manufacture
Professional Competence:	manager development
Date:	30 th June 2017