

Manual

Double flashlights



WBA-1

Item no. 53-03015 | 53-03016

WBA-2

Item no. 53-03020



WBA-3

Item no. 53-03035 | 53-03036

Table of contents

1. Getting started.....	3
2. Safety instructions.....	4
3. Safe and correct soldering.....	6
4. Operation overview.....	8
5. Technical specifications.....	9
6. Assembling the kit.....	10
7. Connecting the double flashlight.....	14
8. Check list for troubleshooting.....	18
9. Guarantee bond.....	20
10. EU declaration of conformity.....	21
11. Declarations conforming to the WEEE directive.....	21

© 12/2015 Tams Elektronik GmbH

All rights reserved. No part of this publication may be reproduced or transmitted in any form or by any means, electronic or mechanical, including photocopying, without prior permission in writing from Tams Elektronik GmbH.

Subject to technical modification.

1. Getting started

How to use this manual

This manual gives step-by-step instructions for safe and correct assembly of the kit and fitting and connecting of the ready-built module, and operation. Before you start, we advise you to read the whole manual, particularly the chapter on safety instructions and the checklist for trouble shooting. You will then know where to take care and how to prevent mistakes which take a lot of effort to correct.

Keep this manual safely so that you can solve problems in the future. If you pass the kit or the ready-built module on to another person, please pass on the manual with it.

Intended use

The double flashlights WBA-1, WBA-2 and WBA-3 are designed to be operated according to the instructions in this manual in model building and with model railways. Any other use is inappropriate and invalidates any guarantees.

The double flashlights should not be assembled or mounted by children under the age of 14.

Reading, understanding and following the instructions in this manual are mandatory for the user.

Checking the package contents

Please make sure that your package contains:

- one kit WBA-1 or WBA-3, containing the components listed in the parts list (page 12) and one PCB or
- one ready-built module WBA-1, WBA-2 or WBA-3,
- a CD (containing the manual and further information).

Required materials

For assembling the kit you need:

- an electronic soldering iron (max. 30 Watt) or a regulated soldering iron with a fine tip and a soldering iron stand,
- a tip-cleaning sponge,
- a heat-resistant mat,
- a small side cutter and wire stripper,
- as necessary a pair of tweezers and long nose pliers,
- electronic tin solder (0,5 mm. Diameter),
- thin connecting wire.

2. Safety instructions

Mechanical hazards

Cut wires can have sharp ends and can cause serious injuries. Watch out for sharp edges when you pick up the PCB.

Visibly damaged parts can cause unpredictable danger. Do not use damaged parts: recycle and replace them with new ones.

Electrical hazards

- Touching powered, live components,
 - touching conducting components which are live due to malfunction,
 - short circuits and connecting the circuit to another voltage than specified,
 - impermissibly high humidity and condensation build up
- can cause serious injury due to electrical shock. Take the following precautions to prevent this danger:
- Never perform wiring on a powered module.
 - Assembling and mounting the kit should only be done in closed, clean, dry rooms. Beware of humidity.

- Only use low power for this module as described in this manual and only use certified transformers.
- Connect transformers and soldering irons only in approved mains sockets installed by an authorised electrician.
- Observe cable diameter requirements.
- After condensation build up, allow a minimum of 2 hours for dispersion.
- Use only original spare parts if you have to repair the kit or the ready-built module.

Fire risk

Touching flammable material with a hot soldering iron can cause fire, which can result in injury or death through burns or suffocation. Connect your soldering iron or soldering station only when actually needed. Always keep the soldering iron away from inflammable materials. Use a suitable soldering iron stand. Never leave a hot soldering iron or station unattended.

Thermal danger

A hot soldering iron or liquid solder accidentally touching your skin can cause skin burns. As a precaution:

- use a heat-resistant mat during soldering,
- always put the hot soldering iron in the soldering iron stand,
- point the soldering iron tip carefully when soldering, and
- remove liquid solder with a thick wet rag or wet sponge from the soldering tip.

Dangerous environments

A working area that is too small or cramped is unsuitable and can cause accidents, fires and injury. Prevent this by working in a clean, dry room with enough freedom of movement.

Other dangers

Children can cause any of the accidents mentioned above because they are inattentive and not responsible enough. Children under the age of 14 should not be allowed to work with this kit or the ready-built module.



Caution:

Little children can swallow small components with sharp edges, with fatal results! Do not allow components to reach small children.

In schools, training centres, clubs and workshops, assembly must be supervised by qualified personnel.

In industrial institutions, health and safety regulations applying to electronic work must be adhered to.

3. Safe and correct soldering



Caution:

Incorrect soldering can cause dangers through fires and heat. Avoid these dangers by reading and following the directions given in the chapter **Safety instructions**.

- Use a small soldering iron with max. 30 Watt or a regulated soldering iron.
- Only use electronic tin solder with flux.
- When soldering electronic circuits never use soldering-water or soldering grease. They contain acids that can corrode components and copper tracks.
- Insert the component connecting pins into the PCB's holes as far as possible without force. The components should be close to the PCB's surface.

- Observe correct polarity orientation of the parts before soldering.
- Solder quickly: holding the iron on the joints longer than necessary can destroy components and can damage copper tracks or soldering eyes.
- Apply the soldering tip to the soldering spot in such a way that the part and the soldering eye are heated at the same time. Simultaneously add solder (not too much). As soon as the solder becomes liquid take it away. Hold the soldering tip at the spot for a few seconds so that the solder flows into the joint, then remove the soldering iron.
- Do not move the component for about 5 seconds after soldering.
- To make a good soldering joint you must use a clean and unoxidised soldering tip. Clean the soldering tip with a damp piece of cloth, a damp sponge or a piece of silicon cloth.
- Cut the wires after soldering directly above the soldering joint with a side cutter.
- After placing the parts, please double check for correct polarity. Check the PCB tracks for solder bridges and short circuits created by accident. This would cause faulty operation or, in the worst case, damage. You can remove excess solder by putting a clean soldering tip on the spot. The solder will become liquid again and flow from the soldering spot to the soldering tip.

4. Operation overview

The double flashlights WBA-1, WBA-2 and WBA-3 have been designed to control LEDs. The circuit's two outputs are alternately switched on and off. Fields of application are e.g. St. Andrew's crosses, the flash lights of emergency or roadworks vehicles or signal lamps.

Flashing frequency

The flashing frequency of the double flashlights WBA-1 and WBA-2 cannot be altered. Due to component tolerances it is 1 to 2 Hz. Thus the time period between two flashes is one to a half second.

With the flashlight WBA-3 the flashing frequency can be set at a trimmpot to 0,2 to 0,4 Hz. The time period between two flashes is 5 to 0.25 seconds then.

Connecting LEDs

The LEDs are connected directly to the outputs, the required series resistors are integrated in the circuit. Each output enables the connection of one LED, two LEDs in parallel or several LEDs in series. The maximum number of LEDs that can be connected in series to one output depends on the available voltage and the fluorescent color of the LEDs.

5. Technical specifications

Supply voltage	12 – 18 Volt a.c. or d.c. voltage	
Current consumption (including LEDs)	approx . 5 mA	
Number of outputs	2	
Max. current per output	5 mA	
Flashing frequency	WBA-1	1 – 2 Hz
	WBA-2	1 – 2 Hz
	WBA-3	0,2 – 4 Hz (adjustable)
Periodic time	WBA-1	1 – 0.5 seconds
	WBA-2	1 – 0.5 seconds
	WBA-3	5 – 0.25 seconds (adjustable)
Protected to	IP 00	
Ambient temperature in use	0 ... +60 °C	
Ambient temperature in storage	-10 ... +80 °C	
Comparative humidity allowed	max. 85 %	
Dimensions of the PCB (approx.)	WBA-1	23 x 26 mm
	WBA-2	10 x 10 x 3 mm
	WBA-3	23 x 29 mm
Weight of the circuit (approx.)	WBA-1	5 g
	WBA-2	0.5 g
	WBA-3	6 g

6. Assembling the kit

You can skip this part if you have purchased a ready-built module.

Preparation

Put the sorted components in front of you on your workbench.

The separate electronic components have the following special features you should take into account in assembling:

Resistors

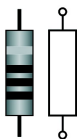

Resistors reduce current.

The value of resistors for smaller power ratings is indicated through colour rings. Every colour stands for another figure. Carbon film resistors have 4 colour rings. The 4th ring (given in brackets here) indicates the tolerance of the resistor (gold = 5 %).

Value:	Colour rings:
2,2 k Ω	red - red - red (gold)
4,7 k Ω	yellow - violet - red (gold)
330 k Ω	orange - orange - yellow (gold)
470 k Ω	yellow - violet - yellow (gold)

Trimm-potentiometers

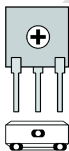

Trimm-potentiometers (abrv. "trimm-pots") are resistors which allow the value of resistance to be varied and that way to be adapted to the particular demands. In the middle they have a small slot into which a small screwdriver can be put in order to vary the value of resistance. The maximum value is printed on the housing.

Depending on the mounting situation trimmpots with a lying or a standing package are used.

Electrolytic capacitors

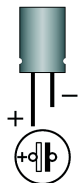

Electrolytic capacitors are often used to store energy. In contrast to ceramic capacitors they are polarized. The value is given on the package.

Electrolytic capacitors are available with different voltage sustaining capabilities. Using an electrolytic capacitor with a voltage sustaining capability higher than required is always possible.

Diodes

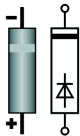

Diodes allow the current to pass through in one direction only (forward direction), simultaneously the voltage is reduced by 0,3 to 0,8 V. Exceeding of the limit voltage always will destroy the diode, and allow current to flow in the reverse direction.

The diode type is printed on the package.

Transistors

Transistors are current amplifiers which convert low signals into stronger ones. There are several types in different package forms available. The type designation is printed on the component.

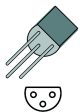

Transistors for a low power rating (e.g. BC types) have a package in form of a half cylinder (SOT-package).

The three pins of bipolar transistors (e.g. BC types) are called basis, emitter and collector (abbreviated with the letters B, E, C in the circuit diagram). T

PCB sockets

The widely spread 2.5 or 2.6 mm model railway connectors fit exactly to the sockets. These are used for the connection to the voltage supply and to connected modules or components.

WBA-1: PCB layout and parts list

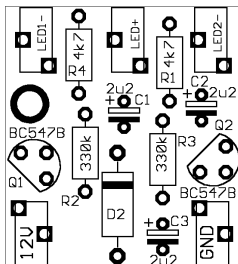

Resistors	R1, R4	4,7 k Ω
	R2, R3	330 k Ω
Diodes	D2	1N4148
Electrolytic capacitors	C1, C2, C3	2,2 μ F
Transistors	T1, T2	BC547B
PCB sockets	LED1- LED2- LED+ 12V GND	

WBA-3: PCB layout and parts list

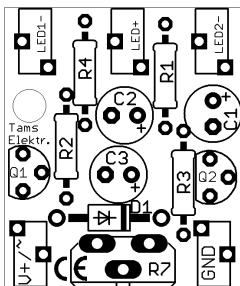

Resistors	R1, R4	2,2 k Ω
	R2, R3	470 k Ω
Trimm-pot	R7	500 k Ω
Diodes	D1	1N400x, x=2...7
Electrolytic capacitors	C1, C2, C3	2,2 μ F
Transistors	Q1, Q2	BC547B
PCB sockets	LED1- LED2- LED+ V+/~ GND	

Assembly

Proceed according to the order given in the list below. First solder the components on the solder side of the PCB and then cut the excess wires with a side cutter. Follow the instructions on soldering in section 3.

 **Caution:** Several components have to be mounted according to their polarity. When soldering these components the wrong way round, they can be damaged when you connect the power. In the worst case the whole circuit can be damaged. At the best, a wrongly connected part will not function.

1.	Resistors	Mounting orientation of no importance.
2.	Diodes	Observe the polarity! The negative end of the diodes is marked with a ring. This is shown in the PCB layout.
3.	PCB sockets	
4.	Transistors	Observe the polarity! The cross section of transistors for a low power rating in SOT-packages is shown in the PCB layout.
5.	Electrolytic capacitors	Observe the polarity! One of the two leads (the shorter one) is marked with a minus sign.
6.	Trimm-potentiometers (WBA-3 only)	The mounting orientation is preset by the layout of the three pins.

Performing a visual check

Perform a visual check after the assembly of the module and remove faults if necessary:

- Remove all loose parts, wire ends or drops of solder from the PCB. Remove all sharp wire ends.
- Check that solder contacts which are close to each other are not unintentionally connected to each other. Risk of short circuit!
- Check that all components are polarised correctly.

When you have remedied all faults, go on to the next part.

7. Connecting the double flashlight

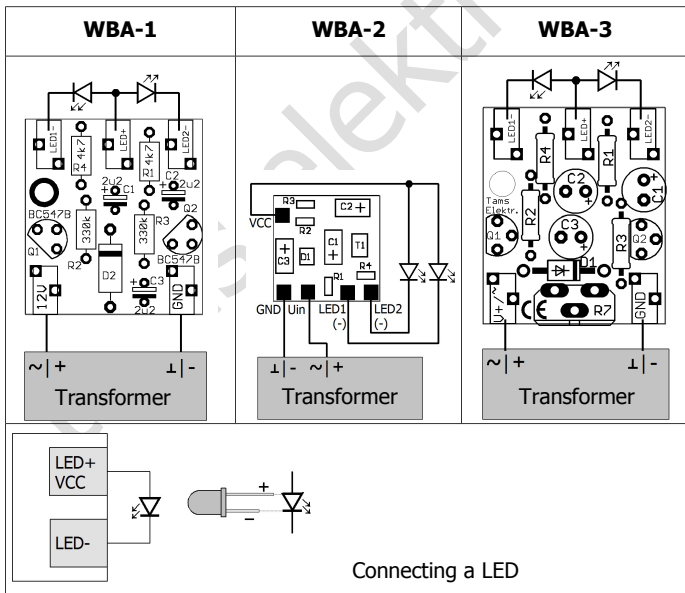

Connection to the power supply

Connect the double flashlight according to the figures and the list, to the power supply. When connecting the PCB to (analogue) a.c. voltage, the connections' polarity is not relevant. When connecting the PCB to (analogue) d.c. voltage, you have to observe the connections' polarity.

	Power supply	
	d.c. voltage	a.c. voltage
GND	-	Polarity not relevant
12V (WBA-1) Uin (WBA-2) U+/~ (WBA-3)	+	

Use in non digital D.C. layouts

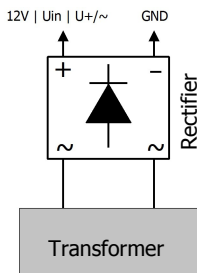

The LEDs shine in one direction of travel only when the double flashlight is used in vehicles run in railway layouts supplied by (analogue) d.c. voltage. If they should work in both directions of travel, mount an additional bridge rectifier (e.g. item no. 83-19100-10, not included in delivery) according to the figure.

Connection to a decoder output

Connect the connection "GND" to the output of the locomotive or function decoder you intend to switch the double flashlight. Connect the connection "12V", "Uin" or "U+/~" to the return conductor of the output or the return conductor for all outputs.

Info: Light emitting diodes (LEDs)

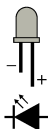

When operated in the forward direction the LEDs light. They are available in several different versions (differing in colour, size, form, luminosity, maximum current, voltage limits). The longer lead of wired LEDs is normally the anode (positive pole). With SMD-LEDs the cathode normally is shown by a mark on the housing.

When using LEDs you always have to limit the current conduction (e.g. by mounting a series resistor), otherwise they will be damaged after a short operating duration. There are series resistors integrated on the double flashlight PCB. Thus it is possible to connect LEDs directly.

Connecting several LEDs to one output

You can connect two LEDs of the same type in parallel or several LEDs in series to each of the two outputs. The maximum number of LEDs you can connect in series to one PCB depends on the voltage supplied and the fluorescent colour of the LEDs.

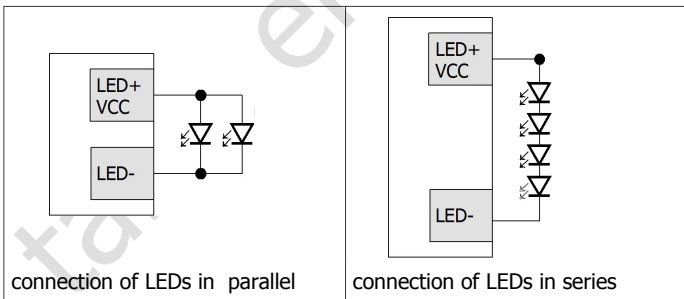

Maximum number of LEDs per output connected in series

Forward voltage of the LEDs* ¹	Nominal operating voltage of the transformer (=)* ²	Max. number of LEDs* ³	Nominal operating voltage of the transformer (~)* ²	Max. number of LEDs* ³
2 V	12 V 12 V	5	12 V approx. 17 V	7
4 V	12 V 12 V	2	12 V approx. 17 V	3
2 V	16 V 16 V	7	16 V approx. 22 V	10
4 V	16 V 16 V	3	16 V approx. 22 V	5
2 V	18 V 18 V	8	18 V approx. 25 V	11
4 V	18 V 18 V	4	18 V approx. 25 V	5

*¹ The forward voltage of white and blue LEDs is approx. 4 V, differing coloured LEDs approx. 2 V.

*² Nominal voltage and operating voltage: The operating voltage with a.c. transformers is approx. 1,4 times the nominal voltage given on the transformer. With d.c. power packs the operating voltage corresponds to the given nominal voltage.

*³ Tolerance and / or voltage fluctuations in practice often cause the calculated operating voltage not being available. For that reason it is recommended to connect one LED less than possible in theory.

Using as a single flashlight

The module can also be used as a single flashlight. For that purpose you must replace one LED with a wire bridge. Compared to when LEDs are connected to both outputs, the flashing frequency is a little faster.

Adjusting the frequency of the WBA-3

In order to adjust the flashing frequency of the WBA-3 insert a small screwdriver into the trimpot's slot. When turning the screwdriver as far as possible to the left the highest frequency (= quickest possible flashing sequence) is set, when turning it as far as possible to the right the lowest frequency (slowest possible flashing sequence) is set.

8. Check list for troubleshooting

- Parts are getting too hot and/or start to smoke.



Disconnect the system from the mains immediately!

Possible cause: one or more components are soldered incorrectly.
→ In case you have mounted the module from a kit, perform a visual check (→ section 6.) and if necessary, remedy the faults. Otherwise send in the module for repair.

- The LEDs connected to the module do not light.

Possible cause: The connection to the power supply is interrupted.
→ Check the connections.

Possible cause: One or several LEDs are connected in the wrong direction. → Change the direction!

Possible cause: One or several LEDs are defective. → Check the LEDs.

Possible cause: If connected to direct voltage the connections "GND" and "Uin" or "12V" are incorrectly connected. → Check the connections.

Possible cause: There are more than 2 LEDs connected to one output in parallel or the number of LEDs connected in series to one output is too high. → Decrease the number of the connected LEDs.

- The LEDs only light in one direction of motion.

Possible cause: There is no rectifier mounted in series although connected to direct voltage. → Mount a rectifier.

- Only WBA-1 and WBA-3: One or several LEDs seem to light permanently.

Possible cause: The capacitors are not correctly soldered in.
→ Check the connections of the capacitors.

Hotline: If problems with your module occur, our hotline is pleased to help you (mail address on the last page).

Repairs: You can send in a defective module for repair (address on the last page). In case of guarantee the repair is free of charge for you. With damages not covered by guarantee, the maximum fee for the repair is the difference between the price for the ready-built module and the kit according to our valid price list. We reserve the right to reject repairing a module when the repair is impossible for technical or economic reasons.

Please do not send in modules for repair charged to us. In case of warranty we will reimburse the forwarding expenses up to the flat rate we charge according to our valid price list for the delivery of the product. With repairs not covered by guarantee you have to bear the expenses for sending back and forth.

9. Guarantee bond

For this product we issue voluntarily a guarantee of 2 years from the date of purchase by the first customer, but in maximum 3 years after the end of series production. The first customer is the consumer first purchasing the product from us, a dealer or another natural or juristic person reselling or mounting the product on the basis of self-employment. The guarantee exists supplementary to the legal warranty of merchantability due to the consumer by the seller.

The warranty includes the free correction of faults which can be proved to be due to material failure or factory flaw. With kits we guarantee the completeness and quality of the components as well as the function of the parts according to the parameters in not mounted state. We guarantee the adherence to the technical specifications when the kit has been assembled and the ready-built circuit connected according to the manual and when start and mode of operation follow the instructions.

We retain the right to repair, make improvements, to deliver spares or to return the purchase price. Other claims are excluded. Claims for secondary damages or product liability consist only according to legal requirements.

Condition for this guarantee to be valid, is the adherence to the manual. In addition, the guarantee claim is excluded in the following cases:

- if arbitrary changes in the circuit are made,
- if repair attempts have failed with a ready-built module or device,
- if damaged by other persons,
- if damaged by faulty operation or by careless use or abuse.

10. EU declaration of conformity

 This product conforms with the EC-directives mentioned below and is therefore CE certified.

2004/108/EG on electromagnetic. Underlying standards: EN 55014-1 and EN 61000-6-3. To guarantee the electromagnetic tolerance in operation you must take the following precautions:

- Connect the transformer only to an approved mains socket installed by an authorised electrician.
- Make no changes to the original parts and accurately follow the instructions, connection diagrams and PCB layout included with this manual.
- Use only original spare parts for repairs.

2011/65/EG on the restriction of the use of certain hazardous substances in electrical and electronic equipment (ROHS). Underlying standard: EN 50581.

11. Declarations conforming to the WEEE directive



This product conforms with the EC-directive 2012/19/EG on waste electrical and electronic equipment (WEEE).

Don't dispose of this product in the house refuse, bring it to the next recycling bay.

Information and tips:

<http://www.tams-online.de>

Warranty and service:

Tams Elektronik GmbH

Fuhrberger Straße 4

DE-30625 Hannover

fon: +49 (0)511 / 55 60 60

fax: +49 (0)511 / 55 61 61

e-mail: modellbahn@tams-online.de

