

Battery Spec.---PH-AAA900mAh

1. Scope

This specification is suitable for the performance of following nickel metal hydride cylindrical cell and its stack-up battery packs:

Manufacturer Model: PH-AAA900

Customer B/N

Size: AAA

The data involving nominal voltage and approximate weight of a battery pack shall be equal to the value of the unit cell multiplied by the number of unit cells in the battery pack. An example, for a battery pack which consisting of 3 cells:

Nominal voltage of unit cell = 1.2V

So, nominal voltage of the battery pack = 1.2V×3 = 3.6V

2 Ratings

Type: <u>Ni-MH</u>		Model: <u>AAA900mAh</u>	
Nominal Specifications	Nominal Capacity:900mAh	Nominal Voltage: 1.2V	
	Standard Charge:90mA×15 h	Fast Charge: 450mA×2.5h	
	Trickle Charge: 27~45mA	Cut-off Voltage: 1.0V	
Temperature Range	Standard Charge: 0 ~ 45□	Fast Charge: 10 ~ 40□	
	Trickle Charge: 0 ~ 45□	Discharge: -20 ~ 65□	
	Storage (Within one year) : -20~ 35□		
Humidity Range	65±20%		
Approx Weight	13g		
Dimension (with tube)	Diameter(mm)	10.5 ⁰ _{-0.7}	
	Height(mm)	44.5 ⁰ _{-1.0}	
Appearance	There shall be no such defects as deformation, flaw, stain, discoloration or electrolyte leakage, which may adversely affect the commercial value of the battery.		

3.Performance and Test Methods

Unless special stated, tests should be done within one month of delivery under

Battery Spec.---PH-AAA900mAh

the following conditions:

Ambient Temperature: 20±5℃.

Ambient Humidity: 65±20%.

Test Item	Test Conditions				Requirements
1.Standard Charge	Charge is conducted continuously for 15 hours at the constant current of 90mA after predischage at the constant current of 180mA up to an cut-off voltage of 1.0V.				
2.Open-circuit Voltage	Voltage between terminals of the charged battery specified in item(1) is measured after rest for 1 hour.				≥1.25V
3.Capacity	Discharge time of the charged battery specified in item(1) is measured at 180mA up to an cut-off voltage of 1.0V after rest for 30 minutes. If the discharge time doesn't reach the specified value, the test may be carried out further twice, up to three times in total.				≥300 minutes
4.Capacity (high-rate -discharge)	Discharge time of the charged battery specified in item(1) is measured at 450mA up to an cut-off voltage of 1.0V after rest for 30 minutes. If the discharge time doesn't reach the specified value, the test may be carried out further twice, up to three times in total.				≥110 minutes
5.Cycle Life	Cycle No.	Charge	Rest	Discharge	≥500 cycles
	1	90mA×16h	none	225mA×140min	
	2-48	225mA×190min	none	225mA×140min	
	49	225mA×190min	none	225mA to 1.0V/Batteries	
	50	90mA×16h	1-4h	225mAto 1.0V/Batteries	
Cycles 1 to 50 shall be repeated until the discharge duration on any 50th cycle becomes less than 3h.					

Battery Spec.---PH-AAA900mAh

6.Potential	Discharge time of the charged battery specified in item(1) is measured at 180mA up to an cut-off voltage of 1.0V .	≥240 minutes
7.Internal Resistance	The battery is measured at 1000Hz with charge state.	≤30mΩ
8.Over-charge	Charge is conducted continuously for 48 hours at 90mA after the capacity test specified in item(4).	No deformation and leakage
9.Over-discharge	Discharge is conducted with a 1Ω/cell load for 24 hours.	No external deformation
10.Self-discharge	The charged battery specified in item(1) is stored for 28 days at 20□, and the discharge time is measured at 180mA.	≥180 minutes
11.Storage	The capacity test conducted as specified in item(3) after the battery discharged with 180mA and stored for 18 months under standard condition.	≥300 minutes
12.Humidity	The charged battery is stored for 10 days at 33±3□ and 80±5% of relative humidity.	No electrolyte leakage
13.Safety Valve Operation	Forced discharge is conducted for 30 minutes at a constant current of 900mA after predischage at a constant current of 1800mA up to 0V.	Not explode or disrupt. *
14.External Short-circuit	The charged battery specified in item(1) is short-circuited for 1 hour.	Not explode. *
15.Drop Test	The battery is subjected to a drop, which has a height of 45cm(17.7 inches) to an oak board of 10mm or more thick in a voluntary axis respectively 3 times.	Mechanically and electrically normal
Note: * Electrolyte leakage and deformation of battery are acceptable.		

4. Configuration, Dimensions and Markings

Please refer to the attached drawings.

5. General Characteristics

Battery Spec.---PH-AAA900mAh

Please refer to the attached drawings.

6. Suggestions & Cautions:

- 6.1 The cut-off voltage is recommended at $1.0\pm 0.1V$ /Batteries**
- 6.2 Charge the batteries prior to use.**
- 6.3 Don't solder directly to the battery.**
- 6.4 Don't short circuit and reverse charge.**
- 6.5 Do not dispose of in fire and keep away from damage.**
- 6.6 Store the batteries uncharged in a cool and dry place.**
- 6.7 The batteries' life may be reduced if they are subjected to adverse conditions such as: extreme temperature, deep cycling, excessive overcharge/discharge.**

Battery Spec.---PH-AAA900mAh

Product Name		Sealed Nickel Metal Hydride Cylindrical Rechargeable Battery
Model		H-AAA900mAh
Nominal Voltage		1.2V
Nominal Capacity		900mAh
Dimension (with tube)	Diameter	10.5 ⁺⁰ _{-0.7}
	Height	44.5 ⁺⁰ _{-1.0}
Approx Weight		13g
Internal Resistance at 1000Hz		≤ 30mΩ (After charge)
Charge	Standard	90mA × 15h
	Rapid	900mA × 72min
	Trickle	27~45mA
Discharge Cut-off Voltage		1.0V
Cycle Life		≥ 500 Cycles
Ambient Temperature	Standard Charge	0°C to 45°C
	Rapid Charge	10°C to 45°C
	Trickle Charge	0°C to 45°C
	Discharge	-20°C to 65°C
	Storage	-20°C to 45°C
Ambient Humidity		65±20%

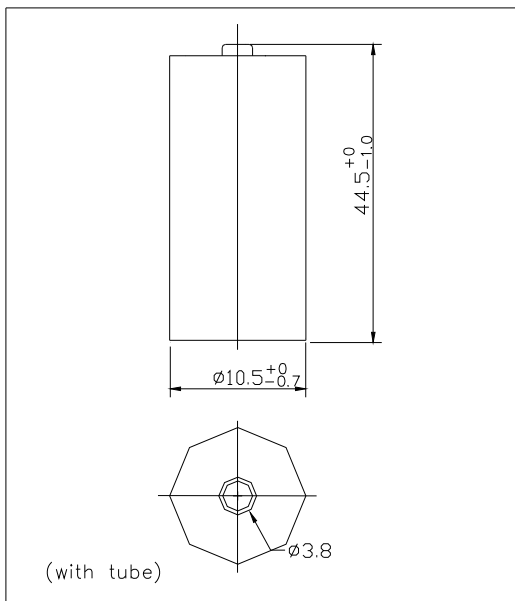

General Characteristics

