



Approve datasheet

Model: ICP622540PMT

Version: V2.0

Description: 3.7V / 550mAh



Renata SA Switzerland

Product Specification

Model No. : ICP622540PMT

Issued Date : 2016/03/10

Version: V 2.0

Model	Description	Rev.	Page
ICP622540PMT	Lithium-ion Polymer Battery Pack	Rev.2.0	2/13

1. Preface

The purpose of this product specification is to provide technical information for the rechargeable Lithium-ion polymer battery pack ICP622540PMT.

2. Description and Model

2.1 Description Rechargeable Lithium-ion Polymer Battery

2.2 Model Pack ICP622540PMT

3. Specifications

3.1 Typical Capacity 600mAh (at 0.2C rate discharge process after standard charge)

3.2 Minimum Capacity 550mAh (at 0.2C rate discharge process after standard charge)

3.3 Charging Voltage 4.2V

3.4 Average working Voltage 3.7V at 0.2C rate

3.5 Standard Charge
Constant current 0.5C
Constant voltage 4.2V
0.05C cut-off

3.6 Fast Charge
Constant current 1.0C
Constant voltage 4.2V
0.05C cut-off

3.7 Discharge Cut-off Voltage 3.0V

3.8 Max. Discharge Current 1.0C

3.9 Max. Charge Current 1.0C

3.10 Cycle Life ≥ 500 cycles, more than 80% at 0.5C rate discharge

3.11 Temperature range of operation

Standard Charge 0°C to 45°C

Discharge -20°C to 60°C

3.12 Weight of Battery Pack Approx. 11.0 g

3.13 Initial Internal Impedance $\leq 220\text{m}\Omega$ (30% SOC)

3.14 Storage At 30% SOC and specified temp, recoverable capacities in % vs time.

-20°C to 25°C (12 months, $\geq 85\%$)

25°C to 45°C (3 months, $\geq 80\%$)

3.15 Recharging Necessity To prevent over-discharge at long storage time, the battery pack shall be charged within 3 months after shipment.

Model	Description	Rev.	Page
ICP622540PMT	Lithium-ion Polymer Battery Pack	Rev.2.0	3/13
<p>4. Outline Dimension</p> <p>See attached drawing for ICP622540PMT (Fig. 1). The thickness is the maximum thickness after 500 cycles.</p> <p>5. Appearance</p> <p>Free from deformation, damage, noticeable scratch, flaw, rust, discoloration or electrolyte leakage.</p> <p>6. Standard Test Condition</p> <p>6.1 Environmental Conditions</p> <p>Unless otherwise specified, all tests shall be conducted within one month of delivery at the temperature $23\pm 5^{\circ}\text{C}$ and the relative humidity $65\pm 20\%$.</p> <p>6.2 Test Equipments</p> <p>(1) Ammeter and voltmeter The ammeter and voltmeter shall have an accuracy of $\pm 0.1\text{mA}$ and $\pm 0.1\text{mV}$, respectively.</p> <p>(2) Slide caliper The slide caliper shall meet with JIS B7507 standard (slide caliper) and have a scale of 0.01 mm.</p> <p>(3) Impedance meter The impedance meter shall be operated at 1 kHz.</p> <p>7. RoHS compliance is for all parts.</p>			

Model	Description	Rev.	Page
ICP622540PMT	Lithium-ion Polymer Battery Pack	Rev.2.0	4/13
8. Test Procedure and its Standard			
Item	Measuring Procedure	Standard	
8.1 Appearance	Visual	No Defects and Leakage	
8.2 Dimension	Caliper for dimension	As item 4	
8.3 Weight	Balance	As item 3.12	
8.4 Initial Open Circuit Voltage	Voltmeter	3.6~3.8V	
8.5 Initial Internal Impedance	Measure the AC impedance at 1kHz	$\leq 220\text{m}\Omega$ (30% SOC)	
8.6 Discharge Capacity	After standard charge, discharge at 0.2C until final discharge voltage of 3.0V and measure the capacity	$\geq 550\text{mAh}$ (min.)	
8.7 Maximum Discharge Current	Until final discharge end voltage of 3.0V	1.0C	

Model	Description		Rev.	Page
ICP622540PMT	Lithium-ion Polymer Battery Pack		Rev.2.0	5/13
8.8 Charge/Discharge Cycle Life	0.5C	Charge: CC- 0.5C, CV-4.2V, Cut-off current: 0.05C	Discharge capacity should be $\geq 80\%$ of 1 st cycle capacity @ 500 th cycle. Rest for 10 minutes between each charge/discharge step.	
		Discharge: 0.5C to 3.0V		
8.9 Leakage Proof	The fully charged battery shall be stored at $65\pm 3^{\circ}\text{C}$ and relative humidity $95\pm 5\%$ for 7 days.		No leakage.	
8.10 Temperature Characteristics	1)Charge:CC/CV,CC-0.5C,CV-4.2V Cut-off 0.05C at $23\pm 3^{\circ}\text{C}$. 2)Discharge: 0.5C to 3.0V at $-10\pm 3^{\circ}\text{C}$ and $\sim 60\pm 3^{\circ}\text{C}$, respectively. Hold for 1 hour after standard charging.		Discharge capacities should be $\geq 60\%$ for $-10\pm 3^{\circ}\text{C}$ and $\geq 95\%$ for $60\pm 3^{\circ}\text{C}$.	
8.11 Self Discharge	Capacity after 30days storage, measured under the same conditions as $23\pm 5^{\circ}\text{C}$ and relative humidity $65\pm 20\%$ environmental test conditions. Data is collected by fully charging the battery, measuring the initial capacity (discharging), recharging the battery, storing the battery, and then measuring the residual capacity after storing.		Residual capacity $\geq 495\text{mAh}$	
9. PCM (Protection Circuit Module) SPECIFICATIONS : (Fig.2)				
9.1 Operating input voltage			1.5 – 12V	
9.2 Current consumption (Operation)			$< 6 \mu\text{A}$	
9.3 Current consumption (Power down)			$< 1 \mu\text{A}$	
9.4 Over-charge threshold voltage			$4.28\text{V} \pm 30\text{mV}$	
9.5 Over-discharge Threshold voltage			$2.8\text{V} \pm 80\text{mV}$	
9.6 Discharge Current Protection			$1.0 \pm 0.3\text{A}$	
9.7 On-State Resistance ($V_B = 3.7\text{V}$)			$\leq 80 \text{m}\Omega$	
9.8 Dimensions			$18.6 \times 4.3 \times 2.6 \text{mm}$	

Model	Description	Rev.	Page
ICP622540PMT	Lithium-ion Polymer Battery Pack	Rev.2.0	6/13
10. Safety Criteria for Acceptance			
Item	State	Test method	Specification
External Short-circuit Test	Fully Charged	Cell terminals are short-circuited for 6 hours or longer with a resistance of $80\pm 20\text{m}\Omega$ or less. Tests are to be conducted at room temperature and 55°C .	NO EXPLOSION or FIRE.
Forced-Discharge Test	Fully Charged	Cell is discharged at a current of 1C rate for 1.5 hours. (If current stops by safety or passive circuit on the battery, test is finished.)	NO EXPLOSION or FIRE.
Heating Test	Fully Charged	The temperature of the oven is to be raised at a rate of $5\pm 2^{\circ}\text{C}/\text{min}$. to a temperature of $130\pm 2^{\circ}\text{C}$, and remains for 10 minutes at this temperature.	NO EXPLOSION or FIRE.
Crush Test	Fully Charged	Crush between two flat plates. Applied force is about 13kN.	NO EXPLOSION or FIRE.
Impact Test	Fully Charged	Impact between bar (15.8mm diameter) and 9.1 Kg falling material (at a height of 61 cm). Bar is laid across the center of the test sample.	NO EXPLOSION or FIRE.
Drop Test	Fully Charged	Drop a fully charged cell onto a concrete floor from the height of 1.0 meters for 3 times.	NO EXPLOSION or FIRE.
Vibration Test	Fully Charged	Vibrate the cell in tri-axial directions each for 90~100 min. in conditions of frequency 10 ~ 55 Hz with amplitude 0.8 mm.	NO EXPLOSION or FIRE.
Abnormal Charge Test	Fully Discharged	Charging the battery by 3C and 4.4 V for 7 hrs.	NO EXPLOSION or FIRE.

Model	Description	Rev.	Page
ICP622540PMT	Lithium-ion Polymer Battery Pack	Rev.2.0	7/13
11. Battery Pack Safety Criteria			
Item	State	Test method	Specification
Overcharge Test	Fully Discharged	<ul style="list-style-type: none"> - Fully charge battery pack Settings: CVC mode: 4.2V, set charging current (0.8C), cut-off by taper current (or end Current) 0.02C. - Continuously charge battery pack Settings: CVC mode: 4.6V, set charging current (0.2C). As the pack enters into protection mode, the charging current become to zero. 	Test passed according to test method.
Over Current Protection	Fully Charged	For the battery pack, set a load of 400mA to check if the pack would not be protected.	Test passed according to test method.
Over-Discharge Test	Fully Charged	<ul style="list-style-type: none"> - Fully charge battery pack Settings: CCD mode set discharging current (0.5C), cut-off voltage (or end voltage) 3.0V. - Continuously discharge battery pack Settings: CCD mode set discharging current (0.2C). End voltage 2.0V. As the pack enters into protection mode, the discharging current become to zero. 	Test passed according to test method.
Short Circuit	Fully Charged	Fully charge battery pack, short +ve & -ve terminal directly. If protected, pack would not be discharged. Then charge by small current, it would be resumed accordingly.	Test passed according to test method.

Model	Description	Rev.	Page
ICP622540PMT	Lithium-ion Polymer Battery Pack	Rev.2.0	8/13

12. Charge State of Battery Before Shipment

The battery is charged to 30 % of minimum capacity. Voltage is 3.6V~3.8V.

This measuring test should be performed within one month after shipment from our factory.

13. Handling Precautions

ICP battery pack shall have enough protection for ICP cell from the specification of electrical, mechanical and environmental characteristics. For use of this battery, must follow specified below. Other than UL1642 or above PACK safety requirement conditions listed may cause major burst, fire, some smokes and it would cause severe performance failure and unsafe for use. Please be sure to follow instructions carefully.

DANGERS:

- (1) Don't disassemble or modify the battery.
The battery has safety function and protection circuit to avoid the danger. ICP cell is packaged by Aluminum laminated plastic film which is easy to be damaged by sharp edge such as pin, needle, edge of devices like nickel tabs, etc. If they have serious damage, electrolyte leakage, short-circuit between positive and negative tabs, etc. It would cause the generation, smoke, rupture, or flaming with mishandling.
- (2) Don't incinerate or heat the battery
Don't use or leave battery nearby fire, stove or heated place (more than 130°C). These occur the melting of insulator, damage of safety function, or ignition on electrolyte. In case that separator made of polymer is melted by high temperature, the internal short-circuit occurs in individual cells and then it would cause the generating, smoke, rupture or flaming.
- (3) Don't use any damage battery
Do not use the battery that are dented or bent on their edge part. ICP batteries are possible to be damaged by strong mechanical shock and it would cause wire break, short-circuit inside the cell, leakage of electrolyte, etc.
- (4) Don't use battery nearby the high temperature place or under the blazing sun.
ICP batteries have possibility to be degraded its performance such as capacity, thickness increase, impendence, etc. The battery will be charged at the abnormal chemical reaction occurs in the high temperature place. The thickness change may lead to stressing on battery case/ device, wiring or cell which may have possibility to lead to damage performance.
- (5) Don't use the unspecified charger.
If the battery is charged with unspecified condition (under high temperature over the regulated value, excessive high voltage or current over regulated value, or remodeled charger with PCM failed or disassemble), there are causes that it will be overcharged or the abnormal chemical reaction will occur in cells. It causes the gas generating, smoke, rupture or flaming.

Model	Description	Rev.	Page
ICP622540PMT	Lithium-ion Polymer Battery Pack	Rev.2.0	9/13
<p>(6) Don't drive a nail into a battery, strike it by hammer, or tread it. As the battery might be broken or deformed and then it will be short-circuited, it would cause the generating, smoke, rupture or flaming.</p> <p>(7) Don't give battery impact or fling it If the protection circuit assembled in the battery is broken, the battery will be charged at abnormal voltage or current and abnormal chemical reaction will occur. It may cause the generating, smoke, rupture or flaming.</p> <p>(8) Don't make the direct ultrasonic wave power to the battery or soldering near the battery It may cause serious damage to the batteries. Soldering near the battery may cause damage of the components, such as separator and insulator, are melted by heat, it would cause the gas generating, smoke, rupture or flaming.</p> <p>(9) Don't reverse polarity (and terminals) If the protection circuit assembled in the battery is broken. On charging, the battery is reversed-charged and abnormal chemical reaction occurs. And also, there may be case that unexpected large current flows on discharging. There causes the generating, smoke, rupture or flaming.</p> <p>(10) Don't reverse-charge or reverse-connect The battery has polarity. In case the battery is not connected with charger or equipment smoothly do not force them to connect and do check polarity of battery. If the battery is connected to opposite polarity with charger. It will be reverse-charged and abnormal chemical reaction will occur. If the protection circuit assembled in the battery is broken, it would cause the generating, swelling, smoke, rupture or flaming.</p> <p>(11) Don't connect battery to the plug socket or car-cigarette-plug Added high voltage to the battery, if the protection circuit assembled in the battery is broken, the excessive current will flow in it and then it may cause the generating, swelling, smoke, rupture or flaming.</p> <p>(12) Don't use battery for another equipment If the battery is used for unspecified equipment, it will deteriorate its performance and cycle-life.</p> <p>(13) Don't touch a leaked battery directly In case the leaked electrolyte gets into eyes, wash them with fresh water as soon as possible without rubbing eyes. And then, see a doctor immediately. If leave damaged eyes undone, it will cause eye-trouble.</p>			
<p>WARNINGS:</p>			
<p>(1) Keep the battery away from babies Keep the little battery out of the reach of babies in order to avoid troubles by swallowing. In case of swallowing the battery, see a doctor immediately.</p>			

Model	Description	Rev.	Page
ICP622540PMT	Lithium-ion Polymer Battery Pack	Rev.2.0	10/13
<p>(2) Don't get into a microwave or a high pressure container Because of sudden heat or damage of sealing condition of battery, it may cause the generating, smoke, rupture or flaming.</p> <p>(3) Don't use a leaked battery nearby fire If the liquid leaks from the battery (or the battery gives out bad smell), let the battery leave from flammable objects immediately. Unless do that, the electrolyte leaked from battery may catch fire and it would cause the smoke, flaming or rupture of it.</p> <p>(4) Don't use an abnormal battery, such as leakage, swelling, deformation, etc. In case the battery has bad smell, it generates, its color change or it is warped in using (includes charging and storage), let it take out from equipment or charger and do not use it. If an abnormal battery is used, it may generate bad performance or damage the device or pack.</p> <p>CAUTIONS:</p> <p>(1) Don't use or leave the battery under the blazing sun (or in heated car by sunshine) The battery may smoke, heat or flame. And also, it might cause the deterioration of battery's characteristics or cycle life.</p> <p>(2) Static Electricity The battery has the protection circuit to avoid the danger. Do not use nearby the place where generates static electricity (more than 100V) which gives damage to the protection circuit. If the protection circuit were broken under abnormal handling, the battery would generate, smoke, rupture or flame.</p> <p>(3) Manual Please read the manual before using the battery and let it keep after reading. And also, please read it necessary.</p> <p>(4) Charging Method Please read the manual of specific charger about charging method.</p> <p>(5) First time use When the battery has rust, bad smell or something abnormal at first-time-using, do not use the equipment and go to the shop which it was bought.</p> <p>DISPOSAL METHOD</p> <p>The used battery is immersed in NaCl 2~3 % water solution for 1 week. Then, it is disassembled and this battery should be handled according to all national laws and regulations.</p>			

Model	Description	Rev.	Page
ICP622540PMT	Lithium-ion Polymer Battery Pack	Rev.2.0	12/13

NO.	PART NAME	DESCRIPTION	QTY.	UM	NOTE
1	Battery	ICP622540	1	EA	Polymer
2	Red Wire	POS. POLE UL3302, AWG26	1	EA	(+)
3	White Wire	NTC. POLE UL3302, AWG26	1	EA	NTC
4	Black Wire	NEG. POLE UL3302, AWG26	1	EA	(-)
5	BKJ73LPR or Same Spec	CIRCUIT PROTECTION	1	EA	PCM
6	Double Coated Adhesive Tape	FOR INSULATING PCM	1	EA	PET
7	Insulating Tape	FOR INSULATING	2	EA	PI
8	Insulating Tape	FOR INSULATING CELL	1	EA	Nomex
9	Insulating Tape	FOR INSULATING +/-	1	EA	(+)

Note:
 Ink marking:
 renata
 ICP622540PMT
 3.7V 550mAh

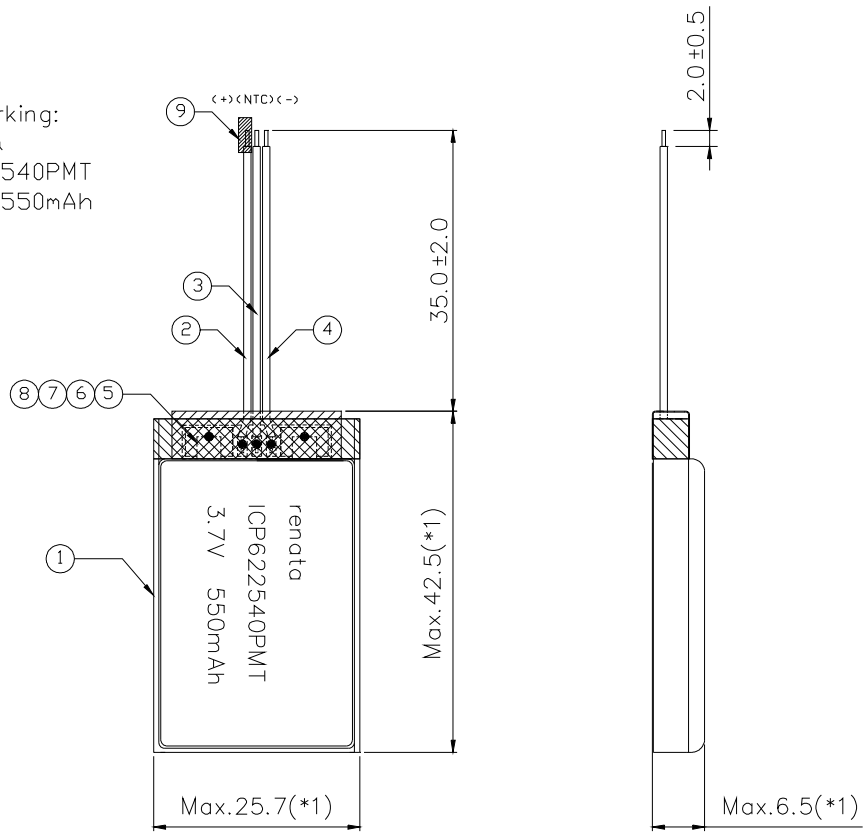

(*1) Measure between two parallel plates with caliper after 500 cycles at fully charged state.

Fig.1

Model	Description	Rev.	Page
ICP622540PMT	Lithium-ion Polymer Battery Pack	Rev.2.0	13/13

Part list:

Item	Qty	Ref	Part name	Number	Maker
1	1	R1	RES	220 Ω \pm 5% 1/16 R1005	SYNTON WAISIN YAGEO
2	1	R2	RES	1K Ω \pm 5% 1/16 R1005	SYNTON WAISIN YAGEO
3	1	R4/ Short	RES	0 Ω \pm 5% 1/4 R3216	SYNTON WAISIN YAGEO
4	2	C1.C2	CAP	100nF +80,-20% 25V C1005	MURATA TDK
5	1	R3	THERMISTER	TSM0A103F34D1RZ	THINKING
6	1	U1	CONTROL IC	S8211	SEIKO
7	1	Q1	FET-CMOS	STS8205	SAMHOP
8	1	PCB	PCB	HP-282	ZEON

Circuit diagram:

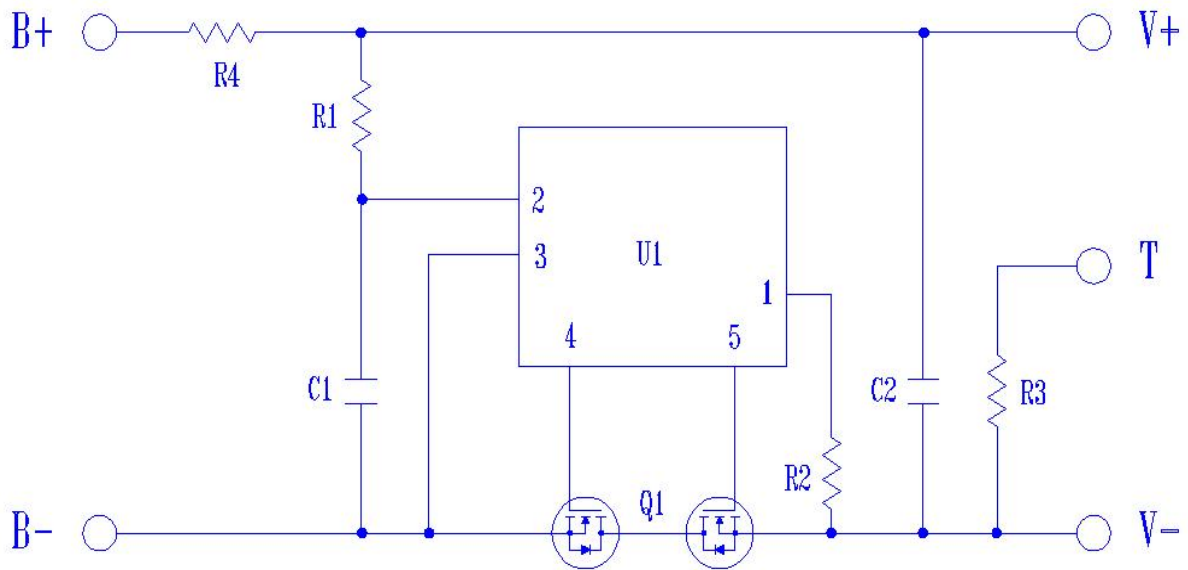

Fig.2