

RIDERSERIES RCM RCM571524

Weidmüller Interface GmbH & Co. KG
 Klingenbergstraße 16
 D-32758 Detmold
 Germany
 Fon: +49 5231 14-0
 Fax: +49 5231 14-292083
 www.weidmueller.com

Product image



Similar to illustration

Standard relays in the RIDERSERIES RCM

- 4 CO contacts
- Optionally AC or DC coils
- with test button
- Comes optionally with integrated status display and/or free-wheel diode

General ordering data

Type	RCM571524
Order No.	8694260000
Version	RIDERSERIES RCM, Relay, No. of contacts: 4 CO contact with test button AgNi 90/10, Rated control voltage: 24 V AC, Continuous current: 6 A, Plug-in connection
GTIN (EAN)	4032248365937
Qty.	10 pc(s).

**RIDERSERIES RCM
RCM571524**

Weidmüller Interface GmbH & Co. KG
 Klingenbergstraße 16
 D-32758 Detmold
 Germany
 Fon: +49 5231 14-0
 Fax: +49 5231 14-292083
 www.weidmueller.com

Technical data**Dimensions and weights**

Width	22.5 mm	Width (inches)	0.886 inch
Height	28 mm	Height (inches)	1.102 inch
Depth	29 mm	Depth (inches)	1.142 inch
Net weight	30.8 g		

Temperatures

Humidity	40 °C / 93 % rel. humidity, no condensation	Operating temperature, max.	70 °C
Operating temperature, min.	-40 °C	Storage temperature, max.	85 °C
Storage temperature, min.	-40 °C	Operating temperature	-40 °C...70 °C
Storage temperature	-40 °C...85 °C		

Environmental Product Compliance

REACH SVHC	Lead 7439-92-1
------------	----------------

Rated data UL

Certificate No. (cURus)	E224238
-------------------------	---------

Input

Rated control voltage	24 V AC	Rated current AC	41.6 mA
Power rating	1.0 VA	Pull-in/drop-out voltage, typ.	19.2 V / 7.2 V AC
Coil resistance	192 Ω ± 10 %		

Output

Rated switching voltage	240 V AC	Max. switching voltage, AC	240 V
Continuous current	6 A	Inrush current	12 A / 20 ms
Switch-on delay	≤ 15 ms	Switch-off delay	≤ 10 ms
Min. switching power	1 mA @ 24 V, 10 mA @ 12 V, 100 mA @ 5 V	Max. switching frequency at rated load	0.1 Hz

Contact data

Contact type	Mechanical service life	
4 CO contact with test button (AgNi 90/10)	AC coil 20 x 10 ⁶ switching cycles, DC coil 30 x 10 ⁶ switching cycles	

General data

Version	Solder connection	Test button	yes (lockable)
Mechanical switch position indicator	Yes	Colour	Transparent
UL 94 flammability rating	V-2		

**RIDERSERIES RCM
RCM571524**

Weidmüller Interface GmbH & Co. KG
 Klingenbergstraße 16
 D-32758 Detmold
 Germany
 Fon: +49 5231 14-0
 Fax: +49 5231 14-292083
 www.weidmueller.com

Technical data
Insulation coordination

Rated voltage	250 V	Surge voltage category	III
Pollution severity	2	Insulating material group	IIIa
Protection degree	IP20	Dielectric strength, Input/Output	2.5 kV _{eff} / 1 Min.
Creepage and clearance distance input – output	≥ 4 mm	Dielectric strength of neighbouring contacts	2 kV _{eff} / 1 min
Dielectric strength of open contact	1.2 kV _{eff} / 1 min.	Impulse withstand voltage	5 kV (1.2/50 µs)

Further details of approvals / standards

Standards	IEC 61810-1, UL508	Certificate No. (CSA)	249409-2426937
Certificate No. (cURus)	E224238		

Connection data

Wire connection method	Plug-in connection
------------------------	--------------------

Classifications

ETIM 3.0	EC001437	ETIM 4.0	EC001437
ETIM 5.0	EC001437	ETIM 6.0	EC001437
UNSPSC	30-21-19-17	eClass 5.1	27-37-16-01
eClass 6.2	27-37-16-01	eClass 7.1	27-37-16-01
eClass 8.1	27-37-16-01	eClass 9.0	27-37-16-01
eClass 9.1	27-37-16-01		

Approvals

Approvals



ROHS	Conform
------	---------

Downloads

Approval/Certificate/Document of Conformity	DE_PA5600_160401_001.pdf
Engineering Data	EPLAN, WSCAD

**RIDERSERIES RCM
RCM571524**

Weidmüller Interface GmbH & Co. KG
 Klingenbergstraße 16
 D-32758 Detmold
 Germany
 Fon: +49 5231 14-0
 Fax: +49 5231 14-292083
 www.weidmueller.com

Drawings

Wiring diagram

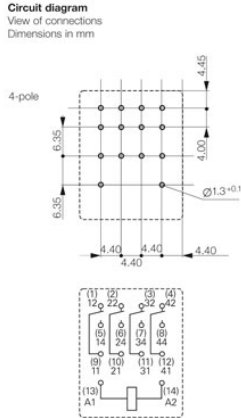

Graph

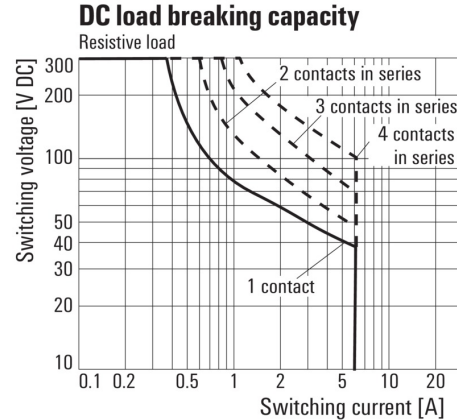

DC load limit curve
Resistive load

Graph

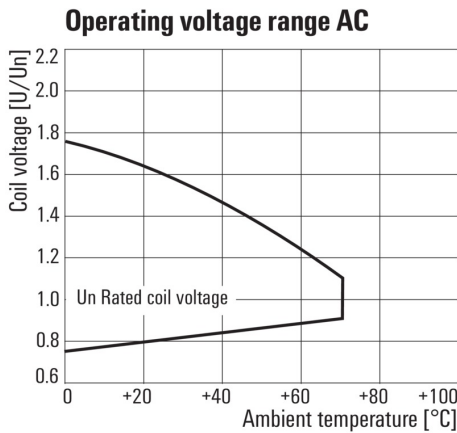

AC operational voltage range

Graph

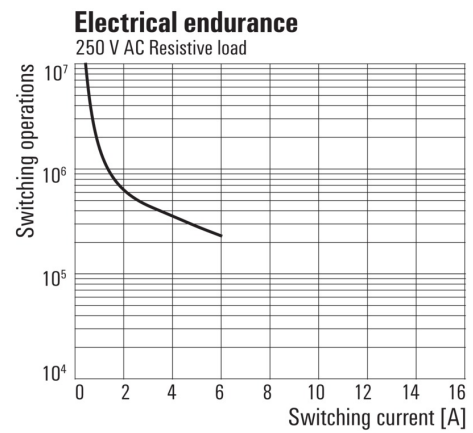

Electrical service life
250 V AC resistive load

Graph

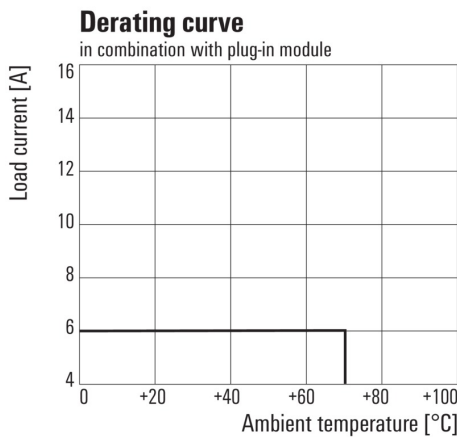

Derating curve
Relay in combination with base

**RIDERSERIES RCM
RCM571524**

Weidmüller Interface GmbH & Co. KG
 Klingenbergstraße 16
 D-32758 Detmold
 Germany
 Fon: +49 5231 14-0
 Fax: +49 5231 14-292083
 www.weidmueller.com

Drawings

Miscellaneous



Type codes