

# GBM-8

Gleisbesetzmelder

Track Busy Indicator

Indicateur d'occupation

Railbesetzmelder

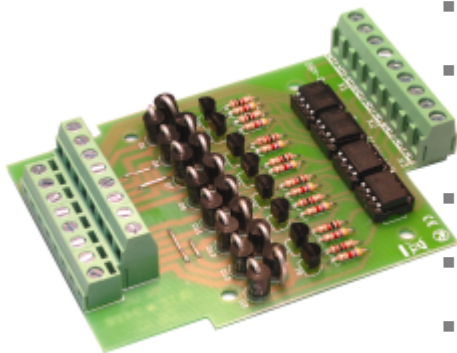

Anleitung

Manual

Mode d'emploi

Handleiding

Art.-Nr. 52-01087 | 52-01086 | 52-01087

Alle Rechte, insbesondere das Recht der Vervielfältigung und Verbreitung sowie der Übersetzung vorbehalten. Vervielfältigungen und Reproduktionen in jeglicher Form bedürfen der schriftlichen Genehmigung durch die Tams Elektronik GmbH.  
Technische Änderungen vorbehalten.

All rights reserved. No part of this publication may be reproduced or transmitted in any form or by any means, electronic or mechanical, including photocopying, without prior permission in writing from Tams Elektronik GmbH.  
Subject to technical modification.

Tout droits réservés, en particulier les droits de reproduction et de diffusion ainsi que le traduction. Toute duplication ou reproduction sous quelque forme que ce soit nécessite l'accord écrit de la société Tams Elektronik GmbH.  
Sous réserve de modifications techniques.

Alle rechten voorbehouden. Niets uit deze publicatie mag worden vermenig-vuldigd opgeslagen of openbaar gemaakt, zonder voorafgaande schriftelijke toestemming van Tams Elektronik GmbH.  
Technische wijzigingen voorbehouden.

© 08/2010 Tams Elektronik GmbH

■		
■		
■		
■		
■		
■		
■		
■		
■	Deutsch	3
■	English	21
■	Français	39
■	Nederlands	57
■		

## Table of contents

1. Getting started	22
2. Safety instructions	24
3. Safe and correct soldering	26
4. Operation overview	27
5. Technical specifications	28
6. Assembling the GBM-8	29
7. Connecting the GBM-8	33
8. Check list for troubleshooting	36
9. CE and Warranty	37

Parts list	I.1
Printed Circuit Board (PCB) layout (Fig. 1)	1.2
Circuit Diagram (Fig. 2)	II
Connections diagram 1: Testing layout (Fig. 3)	III
Connections diagram 2: Connecting the power supply and the track sections (Fig. 4)	IV
Connections diagram 3: Connecting LEDs (Fig. 5)	V
Connections diagram 4: Connecting digital feed back modules (Fig. 6)	VI

(Pages I to VI in the centre of this handbook are removable.)

# 1. Getting started

## How to use this manual

This manual gives step-by-step instructions for safe and correct assembly of the kit and fitting of the module, and operation. Before you start, we advise you to read the whole manual, particularly the chapter on safety instructions and the FAQ chapter. You will then know where to take care and how to prevent mistakes which take a lot of effort to correct.

Keep this manual safely so that you can solve problems in the future. If you pass the kit or the module on to another person, please pass on the manual with it.

## Intended use

The track busy indicator GBM-8 has been designed to be used in analogue or digital model railway layouts in concordance with this manual.

Any other use is inappropriate and invalidates any guarantees.

The kit or the module should not be assembled or fitted by children under the age of 14.

Reading, understanding and following the instructions in this manual are mandatory for the user.



### **Caution:**

The circuit contains integrated circuits. These are very sensitive to static electricity. Do not touch components without first discharging yourself. Touching a radiator or other grounded metal part will discharge you.

## Checking the package contents

Please make sure that your package contains:

- one kit, containing the components listed in the parts list and one PCB,
- or one ready-built module,
- or one complete unit (ready-built module in a housing,
- one manual.

## Required materials

For assembling the kit you need:

- an electronic soldering iron (max. 30 Watt) with a fine tip,
- a soldering iron stand,
- a tip-cleaning sponge,
- a heat-resistant mat,
- a small side cutter and wire stripper,
- a pair of tweezers and long nose pliers,
- tin solder (0,5 mm. diameter),

In order to connect the module you need wire. Recommended diameters:  $\geq 0,25 \text{ mm}^2$  for all connections.

To display the busy status you need:

- LEDs and suitable series resistors and / or
- digital feed back modules (e.g. s88-feed back modules)

## 2. Safety instructions

### Mechanical hazards

Cut wires can have sharp ends and can cause serious injuries. Watch out for sharp edges when you pick up the PCB.

Visibly damaged parts can cause unpredictable danger. Do not use damaged parts: recycle and replace them with new ones.

### Electrical hazards

- Touching powered, live components,
- touching conducting components which are live due to malfunction,
- short circuits,
- connecting the circuit to another voltage than specified,
- impermissibly high humidity,
- condensation build up

can cause serious injury due to electrical shock. Take the following precautions to prevent this danger:

- Never perform wiring on a powered module.
- Assembling and mounting the kit should only be done in closed, clean, dry rooms. Beware of humidity.
- Only use low power for this module as described in this manual and only use certified transformers.
- Connect transformers and soldering irons only in approved mains sockets installed by an authorised electrician.
- Observe cable diameter requirements.
- After condensation build up, allow a minimum of 2 hours for dispersion.
- Use only original spare parts if you have to repair the kit or the ready-built module.

## **Fire risk**

Touching flammable material with a hot soldering iron can cause fire, which can result in injury or death through burns or suffocation. Connect your soldering iron or soldering station only when actually needed. Always keep the soldering iron away from inflammable materials. Use a suitable soldering iron stand. Never leave a hot soldering iron or station unattended.

## **Thermal danger**

A hot soldering iron or liquid solder accidentally touching your skin can cause skin burns. As a precaution:

- use a heat-resistant mat during soldering,
- always put the hot soldering iron in the soldering iron stand,
- point the soldering iron tip carefully when soldering, and
- remove liquid solder with a thick wet rag or wet sponge from the soldering tip.

## **Dangerous environments**

A working area that is too small or cramped is unsuitable and can cause accidents, fires and injury. Prevent this by working in a clean, dry room with enough freedom of movement.

## **Other dangers**

Children can cause any of the accidents mentioned above because they are inattentive and not responsible enough. Children under the age of 14 should not be allowed to work with this kit or the ready-built module.

Little children can swallow small components with sharp edges, with fatal results! Do not allow components to reach small children.

In schools, training centres, clubs and workshops, assembly must be supervised by qualified personnel.

In industrial institutions, health and safety regulations applying to electronic work must be adhered to.

### 3. Safe and correct soldering

**Caution:**

Incorrect soldering can cause dangers through fires and heat. Avoid these dangers by reading and following the directions given in the chapter **Safety instructions**.

- Use a small soldering iron with max. 30 Watt. Keep the soldering tip clean so the heat of the soldering iron is applied to the solder point effectively.
- Only use electronic tin solder with flux.
- When soldering electronic circuits never use soldering-water or soldering grease. They contain acids that can corrode components and copper tracks.
- Solder quickly: holding the iron on the joints longer than necessary can destroy components and can damage copper tracks or soldering eyes.
- Observe correct polarity orientation of semi-conductors, LEDs, electrolytic capacitors and integrated circuits before soldering and ensure that the solder time does not exceed 5 seconds, otherwise components can be damaged.
- Apply the soldering tip to the soldering spot in such a way that the part and the soldering eye are heated at the same time. Simultaneously add solder (not too much). As soon as the solder becomes liquid take it away. Hold the soldering tip at the spot for a few seconds so that the solder flows into the joint, then remove the soldering iron.
- Do not move the component for about 5 seconds after soldering.
- To make a good soldering joint you must use a clean and unoxidised soldering tip. Clean the soldering tip with a damp piece of cloth, a damp sponge or a piece of silicon cloth.
- Cut the wires after soldering directly above the PCB solder side with a side cutter.



- After placing the parts, please double check for correct polarity. Check the PCB tracks for solder bridges and short circuits created by accident. This would cause faulty operation or, in the worst case, damage. You can remove excess solder by putting a clean soldering tip on the spot. The solder will become liquid again and flow from the soldering spot to the soldering tip.

## 4. Operation overview

The track busy indicator GBM-8 can be used in analogue (d.c. or a.c.) layouts as well as in digital layouts. The module can supervise a maximum of eight track sections.

The GBM-8 is internally divided into four sections with two track busy indicators each, which can be connected to a maximum of four different booster or transformer sections.

### Detecting vehicles

With a sensitivity of 5 mA the GBM-8 detects reliably locomotives and carriages with lighting, but not vehicles not consuming current of their own.

Hint: As a rule, the small current flowing after painting a carriage's axle with resistive lacquer is not high enough to be detected by the GBM-8. For this application the fourfold track busy indicator GBM-1\*\* can be used.

Electric consumers located in a switched off track section can be detected by the GBM-8 when an additional resistor is mounted in parallel to the switch.

Due to technical principles, with (analogue) d.c. layouts the GBM-8 can only detect vehicles driving into the supervised track sections in a particular direction. In case the detection of vehicles from both directions is required, the track busy indicator GBM-1\*\* can be used.

## Evaluating and displaying the busy messages

As soon as the GBM-8 detects an electric current consumer in a connected track section, the linked output is internally connected to the output M. This way, the output of the GBM-8 works like a switch switching to earth.

Especially in analogue displays, you can display the busy messages with LEDs (together with suitable series resistors) connected to the outputs. The outputs of the GBM-8 are suitable for a load of maximum 50 mA each. For that reason they are not suitable for the connection of electric light bulbs, relays or subordinate circuits with a current consumption of more than 50 mA. For these applications the fourfold track busy indicator GBM-1\*\* can be used.

In digital layouts, digital feedback modules (e.g. s88-feedback modules) can be connected to the outputs. The eight outputs of the GBM-8 are arranged so as to be connected directly to the inputs of the s88-feedback modules S88-3\*\* oder S88-4\*\*.

The in- and outputs of the GBM-8 are isolated from each other by optocouplers. Consequently interferences are filtered out and hum loops and fault currents are prevented effectively.

## 5. Technical specifications

Supply voltage	from the rails
Current consumption	approx. 15 mA
Sensitivity	approx. 5 mA
Max. current per output	50 mA
Protected to	IP 00
Ambient temperature in use	0 - + 60 °C
Ambient temperature in storage	-10 - + 80 °C
Comparative humidity allowed	max. 85 %
Dimensions	approx. 73 x 96 mm
Weight	approx. 68 g

## 6. Assembling the GBM-8

You can skip this part if you have purchased a ready-built module or a complete unit.

### Preparation

Put the sorted components in front of you on your workbench. The separate electronic components have the following special features you should take into account to prevent mistakes in assembling:

### Resistors



Resistors reduce current. Their mounting orientation is of no importance. The value of resistors for smaller power ratings is indicated through colour rings. Every colour stands for another figure. The colour ring in brackets indicates the tolerance of the resistor which here is of no importance.

Value	Colour rings
1 k $\Omega$	brown - black - red (gold)
4,7 k $\Omega$	yellow - violet - red (gold)

### Diodes

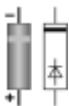

Diodes allow the current to pass through in one direction only (forward direction), simultaneously the voltage is reduced by 0,3 to 0,8 V. Exceeding of the limit voltage always will destroy the diode, and allow current to flow in the reverse direction.

The diode type is printed on the body.

Diodes must be mounted in a given direction. The negative end is marked with a ring. This is shown in the PCB layout.

## Transistors

Transistors are current amplifiers which convert low signals into stronger ones. They have three contacts. As they are polarized, they have to be mounted in a certain direction.



BC-Types have a housing in form of a half cylinder (SOT-housing). The cross section is shown in the PCB layout which determines the mounting orientation.

## Integrated circuits (ICs)

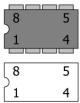

Depending on the type, ICs fulfil various tasks. They are polarized and therefore have to be mounted in a certain direction. The most common housing form is the so-called "DIL"-housing, from which 4, 6, 8, 14, 16, 18 or more "legs" (pins) are arranged along the long sides.

The mounting orientation is shown by a semicircular or circular marking at the end of the housing, which is also shown on the PCB layout.

ICs are sensitive to damage during soldering (heat, electrostatic charging). For that reason in the place of the ICs IC sockets are soldered in, in which the ICs are inserted later. The mounting orientation of the sockets is preset as well. The markings on the PCB, the socket and the IC must lie on top of each other after mounting.

## Opto couplers

Opto couplers are ICs, which work similar to laser beam switches. They combine in one housing a light emitting diode and a photo transistor. Their task is the transmission of information without galvanic connection. Normally they are in a DIL-housing with 4, 6 or 8 pins.

## Terminal strips

Terminal strips are solder-in screw-type terminals. They provide a solder-free and safe connection of the cables to the circuit, which can still be separated any time. When several terminal strips have to be mounted side by side, they have to be put together before mounting.

## Assembling the kit

### **Caution:**

Diodes, transistors, ICs and opto couplers should be inserted in the right direction! If you solder them the wrong way around the affected parts can be damaged when you connect the power. In the worst case the whole circuit can be damaged. At the best, a wrongly connected part will not function.

Start the assembly with the resistors. First solder the components on the solder side of the PCB and then cut the excess wires with the side cutter.

Then insert the four wire bridges Br1 to Br4. Use the off-cut wires of the resistors.

Next solder in the IC-sockets. They have to be mounted according to the marking on the PCB.

Continue the assembly with the transistor, the diodes and the terminal strips. Put together the terminal strips before mounting them.

Finally, insert the opto couplers into the soldered IC-sockets.

### **Caution:**

Do not touch the ICs without first discharging yourself by touching a radiator or other grounded metal parts. Do not bend the "legs" of the ICs when inserting them into the sockets. Check that the markings on the PCB, the socket and the IC show to the same direction.

## Performing a visual check

Perform a visual check after the assembly of the module and remove faults if necessary:

- Remove all loose parts, wire ends or drops of solder from the PCB. Remove all sharp wire ends.
- Check that solder contacts which are close to each other are not unintentionally connected to each other. Risk of short circuit!
- Check that all components are polarised correctly.

When you have remedied all faults, go on to the next part.

## Performing a functional check

It is recommended to perform a functional test after mounting the GBM-8 and before installing it into the layout. In order to simulate a load in a supervised section, use a resistor. A small auxiliary circuit made of a LED, a series resistor 1K and a damping diode, is used to display the busy status. The required components are included in the package.

Follow the connections diagram fig. 3 and the list in section 7. First, make the following connections in order to check if the GBM-8 properly detects and displays the busy status:

1. model railway transformer → connections V1a, V1b and M
2. auxiliary circuit → connections A1 and V1a
3. resistor 1K → connections G1 and V1a



### Caution:

Never connect electric light bulbs to the outputs as these consume more than 50 mA current, as a rule. The outputs which are designed for a maximum current of 50 mA would be destroyed when putting them into operation.

After connecting the transformer with the power supply, the LED should light. Disconnect the connection between G1 and the resistor, the LED should go out.

Repeat the test for all other track sections. Be sure to connect the connections for the power supply, the rails and the output, which are assigned to each other (e.g. V3a, V3b, G5 and A5).

If the functional test is not successful for one or several outputs, check if the opto-couplers and the diodes have been mounted polarized correctly. Follow the hints in section 8, as well.

### **Caution:**

When a component gets too hot, disconnect the module **immediately** from the power supply. Risk of short circuit! Check the assembly.

## 7. Connecting the GBM-8

There are terminal strips soldered to the module's connections, used to plug in and screw on the connection cables.

Each connection for the rails is internally connected to one output. Each pair of connections for the rails is assigned to one connection for the power supply.

Booster section	Rail section	Connections GBM-8		
		Power supply	Rails	Output
1	1	V1a and V1b	G1	A1
	2		G2	A2
2	3	V2a and V2b	G3	A3
	4		G4	A4
3	5	V3a and V3b	G5	A5
	6		G6	A6
4	7	V4a and V4b	G7	A7
	8		G8	A8

Follow the connections diagrams fig. 4, 5 and 6.

### **Connecting the power supply**

Connect the connections for the power supply of the GBM-8 (V1a and V1b or V2a and V2b etc.) to the rail outputs of the driving transformer (in analogue layouts) or the rail outputs of the boosters (in digital layouts). The polarity is not of importance.

As the need arises, you can connect the connections for the power supply (V1, V2, V3, V4) either in parallel to the rail outputs of one booster or transformer or to maximum four different transformers or boosters.

### **Connecting the rail sections**

The busy status can only be reported trouble free, when with each supervised section one conductor is isolated at both ends. In 3-rail systems isolate the middle conductor, in digital 2-rail systems (d.c. layouts) one of the two rails and in analogue 2-rail systems the "-" rail. Pay attention to the fact that, due to technical principles, in analogue 2-rail systems only vehicles driving into the track section in one particular direction are detected.

Connect the isolated conductor (the middle conductor or the isolated rail) of the supervised rail section to one of the rail connections of the GBM-8 (e.g. G1).

Connect the connection "a" for the power supply (e.g. V1a) to the rail conductor which has not been isolated.

Be sure to use the connections for the power supply and the rails which are assigned to each other (e.g. V3a and V3b and G5 and G6).

### **Connecting LEDs**

In order to display the busy status (e.g. in analogue displays), connect the cathodes (-) of the LEDs (with series resistors, e.g. 1 K $\Omega$ ) to the outputs of the GBM-8. Do not use the driving transformer for the power



supply of the LEDs but a separate transformer, for instance one used to supply other lighting circuits.

When connecting the LEDs to an a.c. transformer, you should mount an additional damping diode (e.g. 1N400x, x=2...7) and a capacitor with a value between 10 and 100  $\mu\text{F}$  and an electrical strength of minimum 25 V according to fig. 5.

 **Caution:**

Never connect electric light bulbs to the outputs as these consume more than 50 mA current, as a rule. The outputs which are designed for a maximum current of 50 mA would be destroyed when putting them into operation.

 **Caution:**

Never use LEDs without series resistors, as in this case the LEDs will be destroyed quickly. Apart from that the overcurrent resulting may damage the opto-couplers on the module.

### Connection to digital feed back modules

You can connect the inputs of digital feed back modules (e.g. s88-modules) directly to the outputs of the GBM-8. Connect the earth output of the feed back module to the connection M of the GBM-8 according to fig. 6.

### Supervising switched off rail sections

Rail sections to be switched off during operation (e.g. in a shadow station) can be supervised with the track busy indicator, as well. For that purpose you have to mount a resistor of 1 k $\Omega$  into the lead-in wire of the rail section concerned so that it bridges the switch when the rail section is switched off (see fig. 4 connection to G2)

## 8. Check list for troubleshooting

- Parts are getting too hot and/or start to smoke.



Disconnect the system from the mains immediately!

Possible cause: one or more components are soldered incorrectly.

→ In case you have mounted the module from a kit, perform a visual check (→ section 6.) and if necessary, remedy the faults.

Otherwise send in the module for repair.

- The LEDs connected to the module do not light.

Possible cause: The voltage supply has been interrupted. → Check the connection from the module to the transformer.

Possible cause: One or more LEDs are defective. → Check the LEDs by connecting them directly to the power supply.

**Hotline:** If problems with your module occur, our hotline is pleased to help you (address on the cover page).

**Repairs:** You can send in a defective module for repair (address on the cover page). In case of warranty the repair is free of charge for you. With damages not covered by warranty, the maximum fee for the repair is the difference between the price for the ready-built module and the kit according to our valid price list. We reserve the right to reject the repairing of a module when the repair is impossible for technical or economic reasons.

Please do not send in modules for repair charged to us. In case of warranty we will reimburse the forwarding expenses up to the flat rate we charge according to our valid price list for the delivery of the product. With repairs not covered by warranty you have to bear the expenses for sending back and forth.

## 9. CE and Warranty

### Certification (CE)

This product is developed and tested in accordance with the European standards EN 55014-1 and EN 61000-6-3. This product conforms with the EC-directive 2004/108/EG on electromagnetic radiation and is therefore CE certified.

To guarantee the electromagnetic tolerance in operation you must take the following precautions:

- Connect the transformer only to an approved mains socket installed by an authorised electrician.
- Make no changes to the original parts and accurately follow the instructions, circuit diagram and PCB layout included with this manual.
- Use only original spare parts if you have to repair the kit or the ready-built module.

### Conditions of warranty

This product is guaranteed for two years. The warranty includes the correction of faults which can be proved to be due to material failure or factory flaw.

As we have no control over the correct and proper assembly we can only guarantee the quality of the components and the completeness of kits. We guarantee the function of the components according to the parameters in not mounted state as well as the adherence to the technical specifications of the circuit when assembled and connected according to the manual.

Other claims are excluded. By law, we are not responsible for damages or secondary damages in connection with this product. We retain the right to repair, make improvements, supply spare parts or return the purchase price.

The following invalidate the warranty:

- using an unsuitable soldering iron, solder containing liquid acids or similar,
- if the kit is assembled and soldered poorly, or if damage is caused by not following the instructions in this manual,
- if the ready-built module has been altered and repair attempts have failed,
- if arbitrary changes in the circuit are made,
- if components are removed or swapped, or wiring is added or removed in any other way as laid down in the original design,
- if parts other than the originals delivered with this kit are used,
- if the copper tracks or soldering eyes are damaged,
- when components are mounted incorrectly, or if the components or the circuit are poled incorrectly, also subsequent damage resulting from these faults,
- if damage occurs due to an overload of the module,
- if connected to a incorrect voltage or current,
- if damaged by other persons,
- if damaged by faulty operation or if damaged by careless use or abuse,
- if damaged by touching components before electrostatic discharging of the hands.

### **The asterisks \*\***

\*\* products out of the programme of the Tams Elektronik GmbH

## Stückliste - Parts list - Nomenclature - Stuklijst

Widerstände Resistors Résistances Weerstanden	R9, R10, R11, R12, R13, R14, R15, R16	1 k $\Omega$
	R1, R2, R3, R4, R5, R6, R7, R8	4,7 k $\Omega$
Dioden - Diodes	D1, D2, D3, D4, D5, D6, D7, D8, D9, D10, D11, D12, D13, D14, D15, D16	1N540x
Transistoren - Transistors	T1, T2, T3, T4, T5, T6, T7, T8	BC547B
ICs   ICs   CI 's   ICs	OK1, OK2, OK3, OK4	PC827
IC-Sockel   IC-socket Soquet IC   IC-voetje	OK1, OK2, OK3, OK4	8-pol.
Anreihklemmen   Terminal strips Borniers   Printkroonstenen	X1, X2, X3	3x3-pol.
Doppel-Anreihklemmen Double terminal strips Borniers double Dubbele printkroonstenen	X4	8-pol.
Hilfsschaltung für Funktionstest Auxiliary circuit for functional test Montage pour test de fonctionnement Hulpschakeling voor functietest	Widerstände Resistors Résistances Weerstanden	2 x 1 k $\Omega$
	LED - DEL	
	Diode - Diode	1N4148

Fig. 1: Bestückungsplan | PCB layout  
Plan d'implantation | Printplan

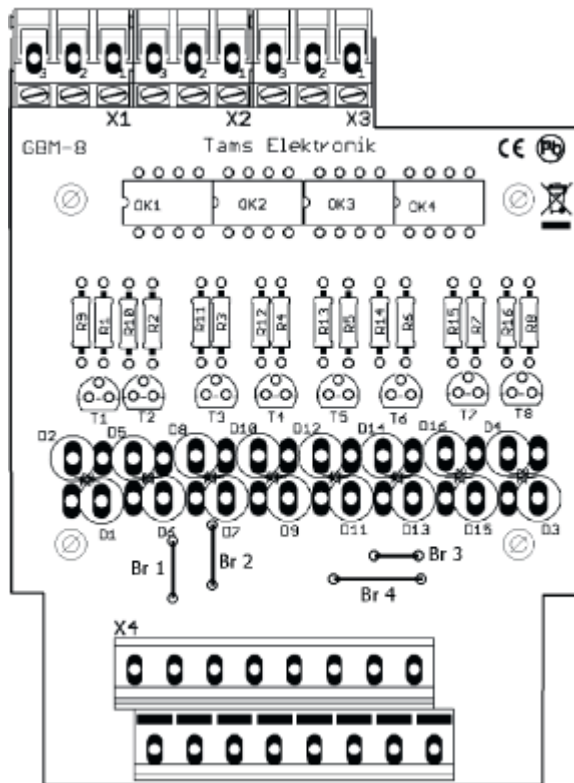

Fig. 2: Schaltplan | Circuit Diagram | Schéma de principe | Schakelschema

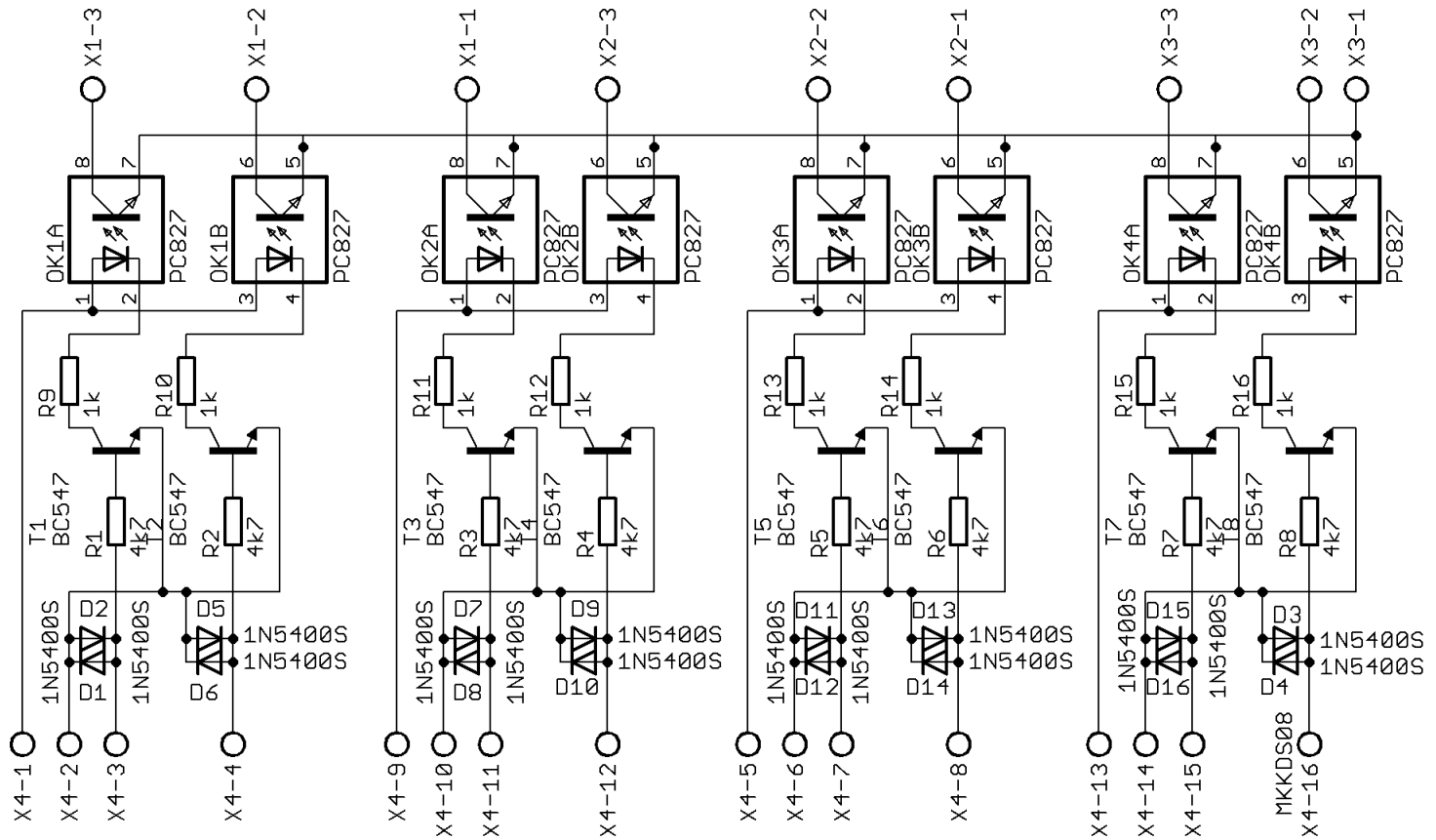

Fig. 3: Anschlussplan 1 | Connection Diagram 1  
Plan de connexion 1 | Aansluitplan 1

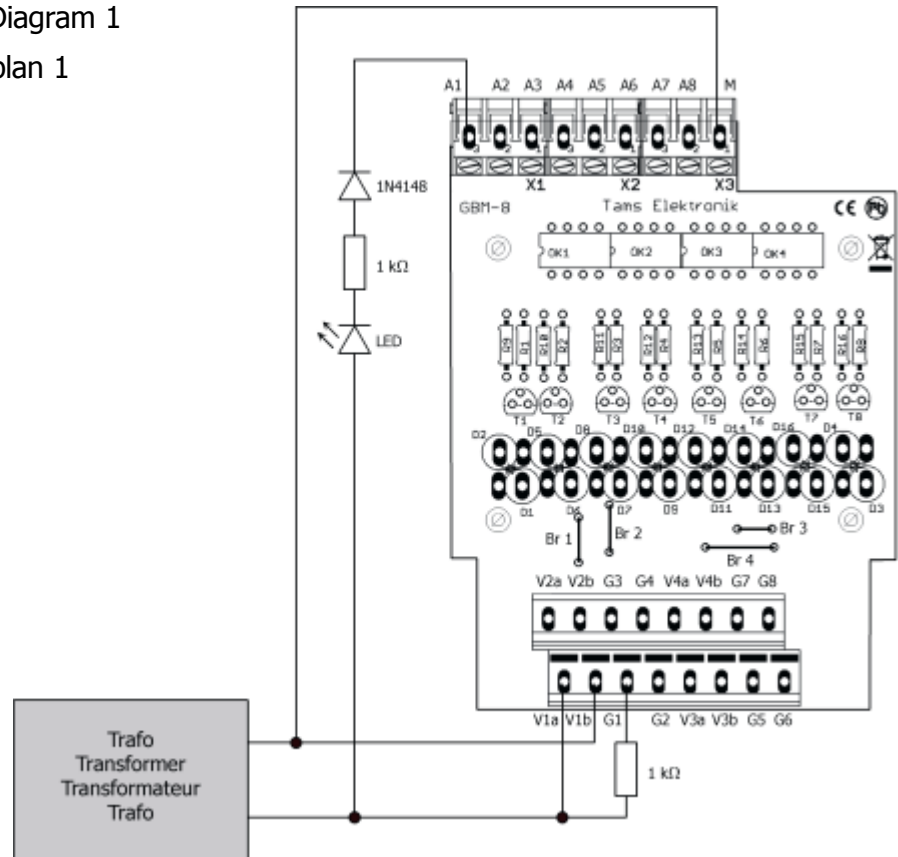



Fig. 4: Anschlussplan 2 | Connection Diagram 2  
Plan de connexion 2 | Aansluitplan 2

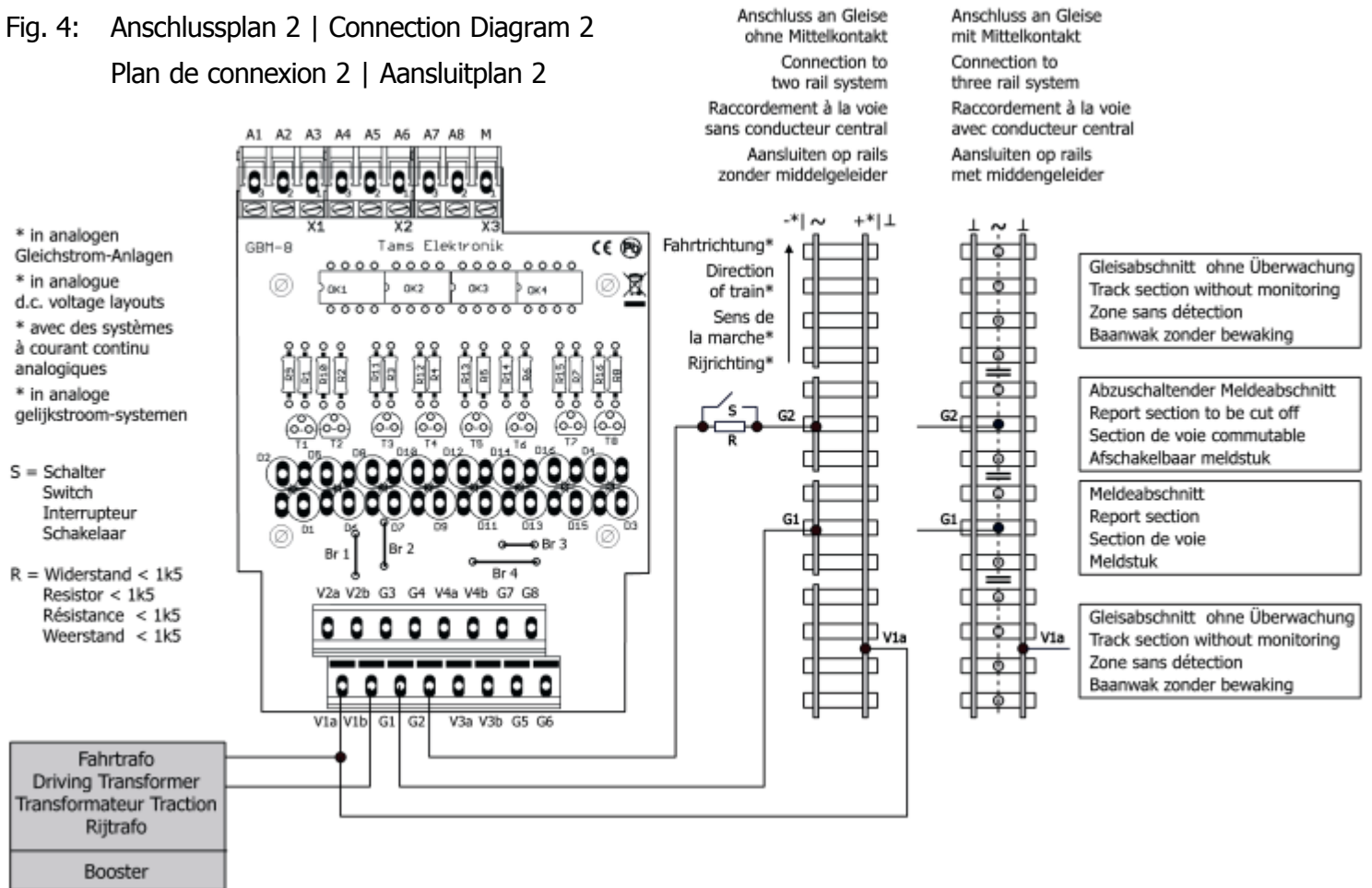

Fig. 5: Anschlussplan 3 | Connection Diagram 3  
Plan de connexion 3 | Aansluitplan 3

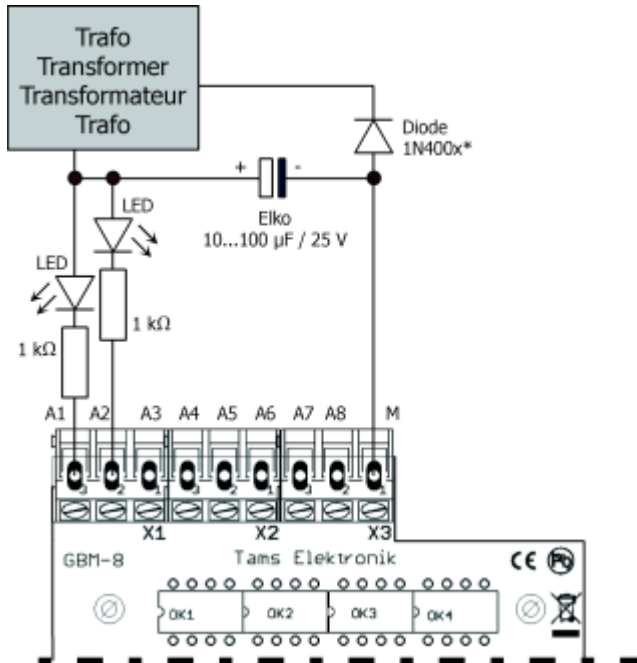
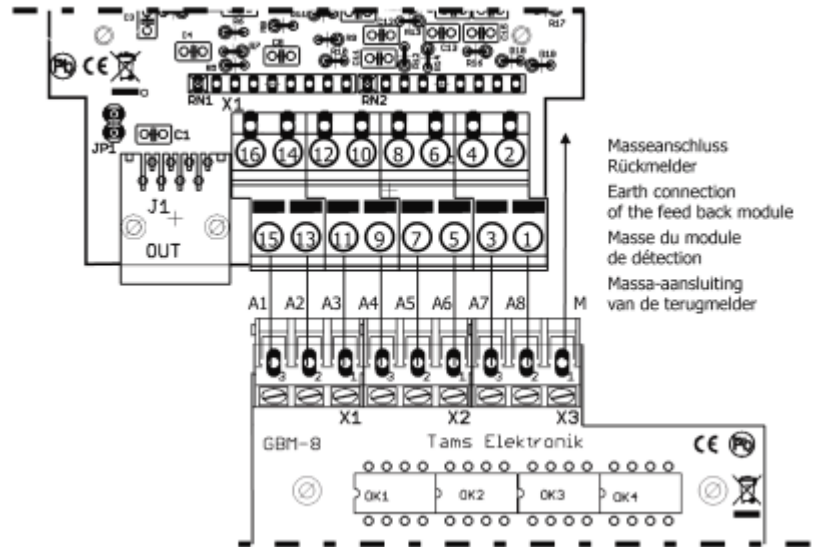

Fig. 6: Anschlussplan 4 | Connection Diagram 4  
Plan de connexion 4 | Aansluitplan 4



Aktuelle Informationen und Tipps:

Information and tips:

Informations et conseils:

Actuele informatie en tips:

<http://www.tams-online.de>

Garantie und Service:

Warranty and service:

Garantie et service:

Garantie en service:

**Tams Elektronik GmbH**

Rupsteinstraße 10

D-30625 Hannover

fon: +49 (0)511 / 55 60 60

fax: +49 (0)511 / 55 61 61

e-mail: [modellbahn@tams-online.de](mailto:modellbahn@tams-online.de)



DE 37847206

