

DCS / DCT / DCU / DCA Thick Film

- State of the Art Thick Film Technology
- Improved Termination Design
- Standard TC: 100 and 200 ppm/K
- Tight Tolerance available: 1 %
- Sizes CECC: 0402 0603 0805 1206
 EIA: 1005 1608 2012 3216

DCS, DCT, DCU and DCA Thick Film Flat Chip Resistors are made for all general purpose applications. They are typically used in the production of office automation equipment and consumer electronics.

The production of the DCS, DCT, DCU and DCA Thick Film Flat Chip Resistors is performed in a mass volume production site. A thick film is screen printed on a high grade alumina ceramic substrate to form the resistive layer. Pre contacts are printed on both sides of the substrate. The resistors are laser trimmed to the target value. The resistor elements are covered by glass and a protective coating combined for superior electrical, mechanical and climatic protection. The prepared terminations receive an electroplating of PbSn solder on nickel plating. A three or four digit code designates the nominal resistance value.

The result of the determined production is verified by a final test performed on 100 % of the individual chip resistors. Only accepted products are laid directly into the paper tape according to IEC 60 286-3.

The resistors are suitable for processing on automatic SMD assembly systems. They are suitable for automatic soldering using wave, reflow or vapour phase. The encapsulation is resistant to all cleaning solvents commonly used in the electronics industry, including alcohols, esters and aqueous solutions.

The resistors are tested according to IEC 60 115 and IEC 60 068. They meet most of the requirements of CECC 40 401-802 and EN 140 400.

This product family of thick film flat chip resistors is complemented by Zero Ohm Jumpers.

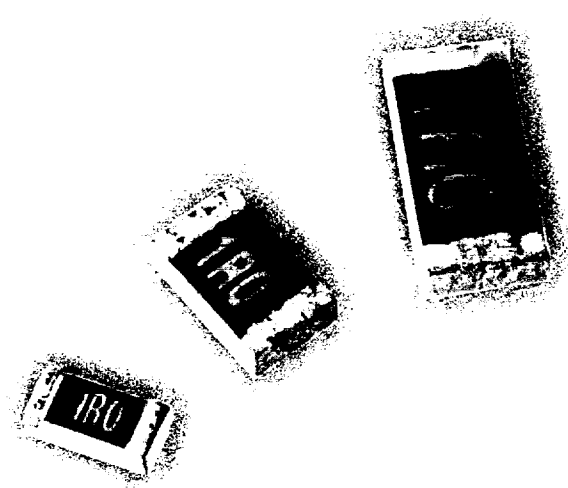

Temperature Coefficient and Resistance Range

	Tolerance	IEC Series	DCS 0402	DCT 0603	DCU 0805	DCA 1206
TC 200	5 %	E24	10 Ω - 1 MΩ	1 Ω - 6,8 MΩ	1 Ω - 10 MΩ	1 Ω - 10 MΩ
	1 %	E24 and E96	-	-	1 Ω - 9,76 Ω 1,02 MΩ - 10 MΩ	1 Ω - 9,76 Ω 1,02 MΩ - 10 MΩ
TC 100	1 %	E24 and E96	-	-	10 Ω - 1 MΩ	10 Ω - 1 MΩ
Jumper			≤ 50 mΩ $I_{\max} = 0,8 \text{ A}$	≤ 50 mΩ $I_{\max} = 0,8 \text{ A}$	≤ 50 mΩ $I_{\max} = 1,1 \text{ A}$	≤ 50 mΩ $I_{\max} = 1,6 \text{ A}$

Introduction
to BEYSCHLAG

Product
Overview

Flat Chip
Resistor Products

MELF
Resistor Products

Leaded
Resistor Products

Resistor Arrays
and Networks

Engineering
Sample Kits

Appendices
and Glossary

Distribution
Network

Electrical Data

Style		DCS 0402	DCT 0603	DCU 0805	DCA 1206
Climatic Category		55 / 125 / 56	55 / 125 / 56	55 / 125 / 56	55 / 125 / 56
Operation Mode (see A4)		Standard	Standard	Standard	Standard
Film Temperature	°C	125	125	125	125
Specified Lifetime	h	8 000	8 000	8 000	8 000

The specification for standard operation mode ensures a maximum temperature of 110 °C at the solder joint on test boards according to CECC 00 802

Thermal Resistance R_{th}	K/W	880	880	440	220
Rated Dissipation P_{70}	W	0,063	0,063	0,125	0,25

Voltage Pulse Load Capability					
Pulse Voltage, U_{max}	V	up to 100	up to 150	up to 300	up to 400
Single Pulse IEC 1,2 / 50	V	–	–	–	–
Energy Pulse Load Capability					
Single Pulse, P_{max}	W	up to 3	up to 4	up to 6	up to 10
Continuous Pulses, P_{max}	W	up to 0,7	up to 1	up to 1,3	up to 2
Current Noise, A_1	$\mu V/V$	down to 0,5	down to 0,5	down to 0,5	down to 0,5
Attenuation 3rd Harmonic, A_3	dB	–	up to 70	up to 80	up to 100

Max. Resistance Change at P_{70} for Resistance Range		10 Ω - 1 M Ω	10 Ω - 1 M Ω	10 Ω - 1 M Ω	10 Ω - 1 M Ω
$\Delta R/R$ after ...					
... 1 000 h	%	≤ 3	$\leq 1,5$	$\leq 1,5$	$\leq 1,5$
... 8 000 h	%	≤ 6	≤ 3	≤ 3	≤ 3

Operating Voltage, U_{max} AC / DC	V	50	50	150	200
Permissible Voltage against Ambient ...					
... 1 minute	V	75	150	150	200
... continuous	V	75	75	75	75
Isolation Resistance	Ω	10^9	10^9	10^9	10^9



Derating • Standard Operation

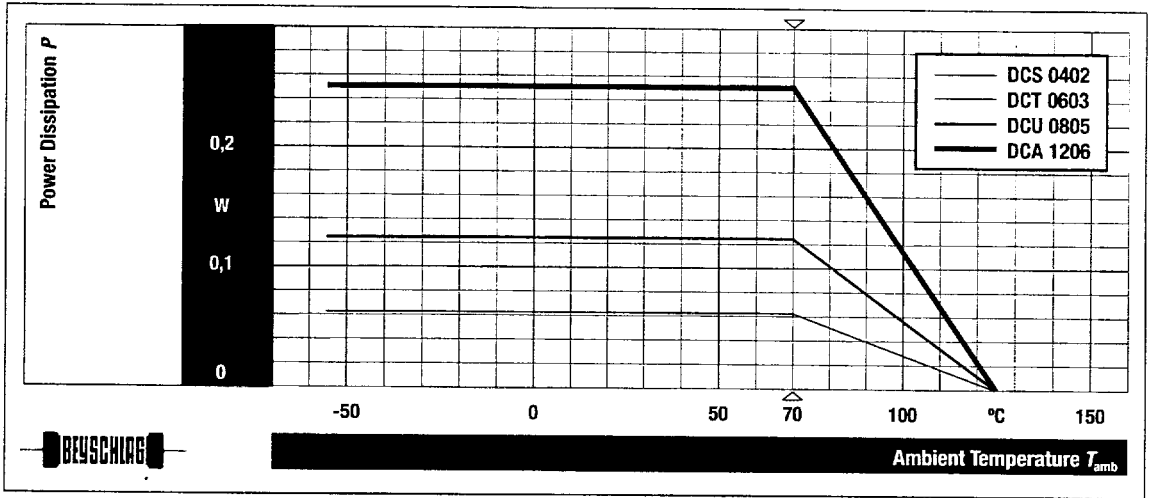

Introduction
to BEYSCHLAG

Product
Overview

Flat Chip
Resistor Products

MELE
Resistor Products

Leaded
Resistor Products

Resistor Arrays
and Networks

Engineering
Sample Kits

Appendices
and Glossary

Distribution
Network



Single Pulse

Maximum Pulse Load (single pulse; see A2)

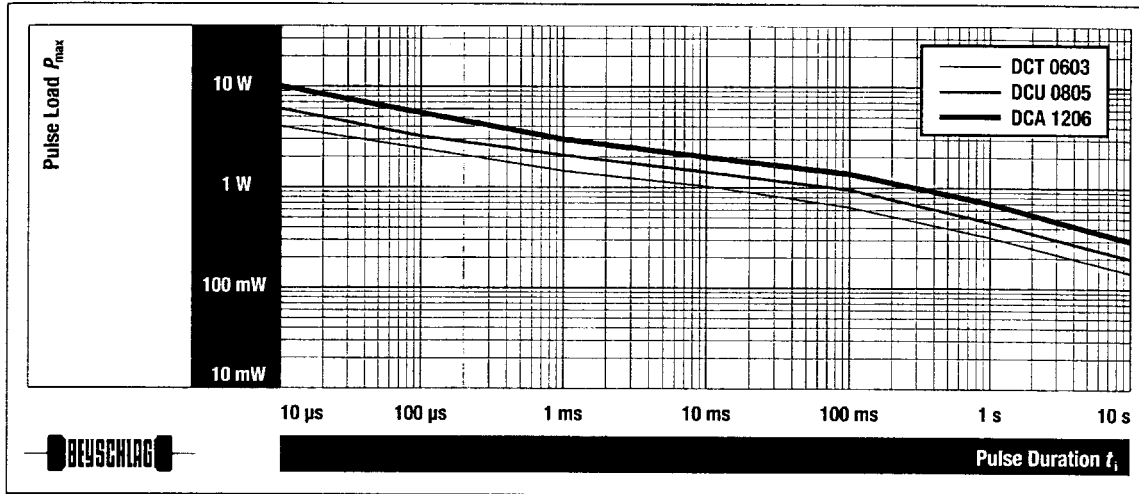

Continuous Pulses

Maximum Pulse Load (continuous pulses; see A2)

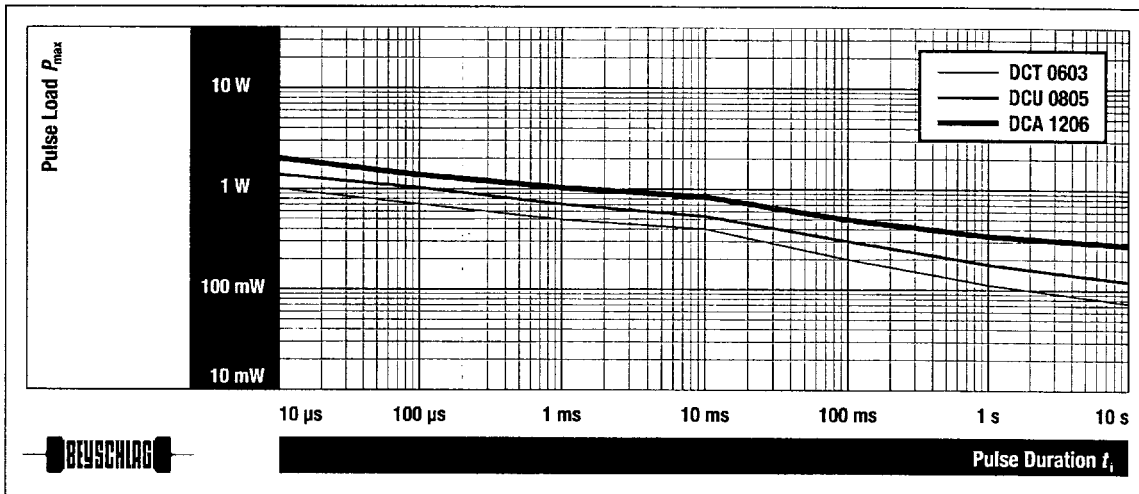

Pulse Load Voltage

Maximum Pulse Voltage (single and continuous pulses; see A2)

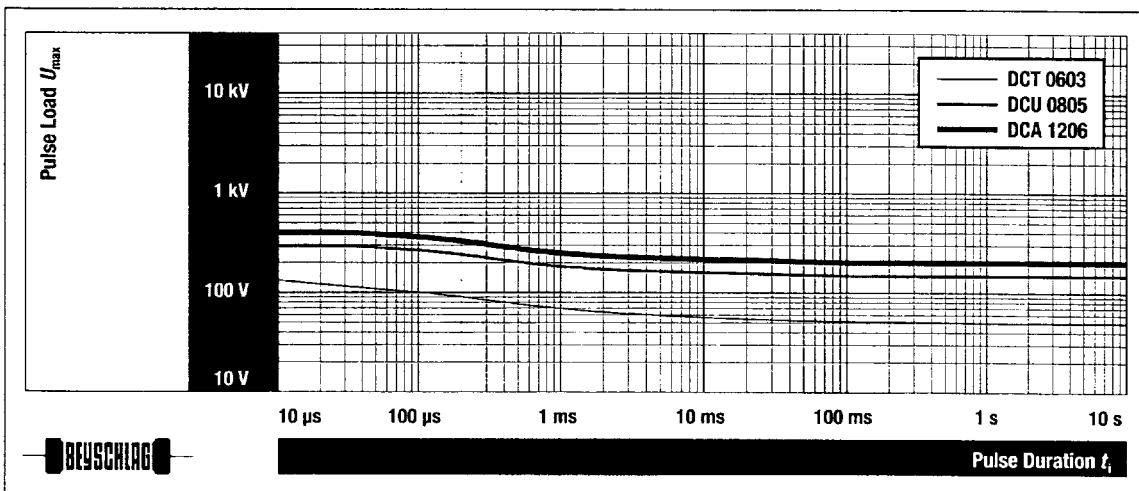

Current Noise

Current Noise A_1 , IEC 60 195

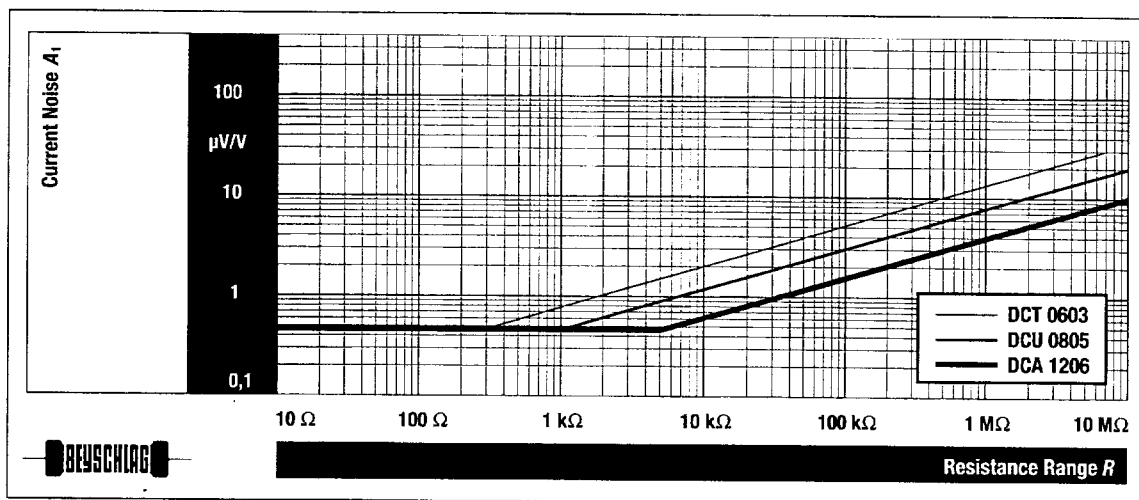

Nonlinearity

Nonlinearity A_3 , IEC 60 440

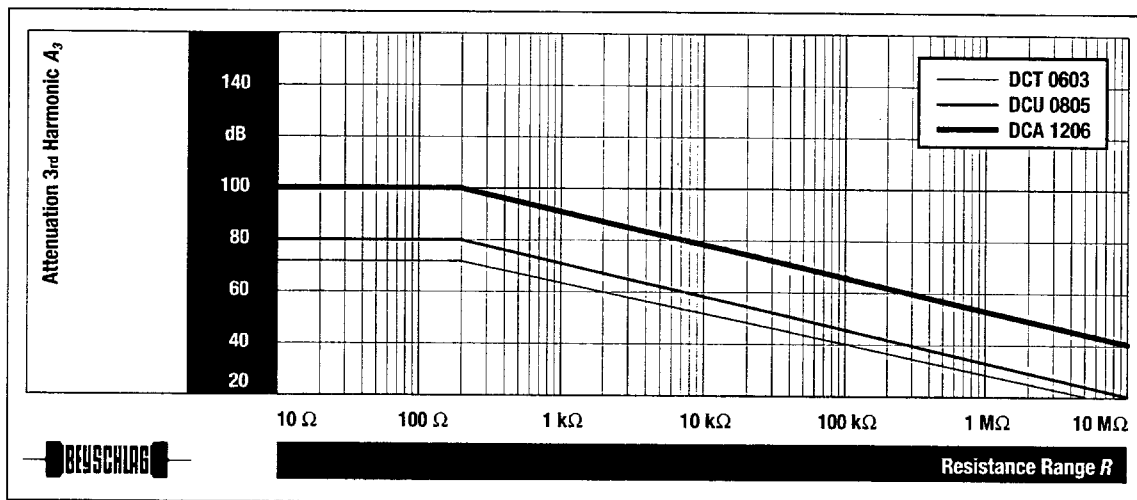

Introduction
to BEYSCHLAG

Product
Overview

Flat Chip
Resistor Products

MELF
Resistor Products

Leaded
Resistor Products

Resistor Arrays
and Networks

Engineering
Sample Kits

Appendices
and Glossary

Distribution
Network

Performance Characteristics

BEYSCHLAG Flat Chip Resistor Products fulfill the requirements of the following specifications:

- EN 140 000 Generic specifications: Fixed Resistors
EN 140 400 Sectional specifications: Fixed low power non-wirewound Resistors

Tests

	IEC 60 115-1 Clause	IEC 60 068-2 (Method)	Test Condition	Permissible Change ΔR		
				DCS 0402	DCT 0603	DCU 0805
				-	-	$\leq 1 M\Omega$
				$\leq 1 M\Omega$	$> 1 M\Omega$	-
				$\leq 1 M\Omega$	$> 1 M\Omega$	-
				$\leq 1 M\Omega$	$> 1 M\Omega$	-
Short-Time Overload *)	4.13		2,5 x rated voltage / 2 x U_{max} for 2 s	$\pm (1\%R+0,05\Omega)$	$\pm (1\%R+0,05\Omega)$	$\pm (2\%R+0,1\Omega)$
Resistance to Soldering Heat	4.18.2	20 (Tb)	+ 260 °C / 10 s	$\pm (0,5\%R+0,05\Omega)$	$\pm (0,5\%R+0,05\Omega)$	$\pm (1\%R+0,1\Omega)$
Rapid Change of Temperature *)	4.19	14 (Na)	5 cycles between - 55 °C / + 125 °C	$\pm (0,5\%R+0,05\Omega)$	$\pm (0,5\%R+0,05\Omega)$	$\pm (2\%R+0,1\Omega)$
Endurance at ...	4.25.1		Rated voltage / U_{max} 1,5 h on / 0,5 h off			
... +70 °C / 1 000 h				$\pm (1,5\%R+0,1\Omega)$	$\pm (3\%R+0,1\Omega)$	$\pm (3\%R+0,1\Omega)$
Climatic Sequence *)	4.23	30 (D)	Dry heat – damp heat (1 cycle) – cold – low air pressure – damp heat (5 cycles)	$\pm (1,5\%R+0,1\Omega)$	$\pm (3\%R+0,1\Omega)$	$\pm (1\%R+0,1\Omega)$
Damp Heat, Steady State 56 Days *)	4.24	3 (Ca)	+ 40 °C / 93 % R.H.	$\pm (1,5\%R+0,1\Omega)$	$\pm (3\%R+0,1\Omega)$	$\pm (3\%R+0,1\Omega)$
Endurance at UCT / 1 000 h	4.25.3	27 (Ba)				
UCT = + 125 °C				$\pm (1,5\%R+0,1\Omega)$	$\pm (3\%R+0,1\Omega)$	$\pm (3\%R+0,1\Omega)$

Requirements

Terminal Adhesion (shear test)			CECC 00 802 / B.2 5 N / 10 s	No visible damage
Voltage Proof (dielectric withstanding voltage)	4.7		$V_{rms} = 100 V / 60 s$	No flashover or breakdown
Solderability	4.17.2	20 (Ta)	+ 215 °C / 3 s	Dipped area shall be covered with a smooth and bright solder coating of at least 95 %
Resistance against Solvents *)		45 (xA)	Alcohols, ester, hydrous solution, + 23 °C, tooth brush method	No mechanical damage Marking must be legible

*) Resistors mounted on a test board according to CECC 00 802

Product Dimensions • Thin Film Chip Resistors

Style	MCS 0402	MCT 0603	MCU 0805	—
		OCT 0603	OCU 0805	
		NCT 0603	NCU 0805	
		TCT 0603	TCU 0805	
CECC - Size	RR 0402	RR 0603	RR 0805	—
EIA - Size	1005	1608	2012	—
H	mm	min 0,27 / max 0,37	min 0,4 / max 0,55	min 0,4 / max 0,55
L	mm	min 0,95 / max 1,05	min 1,5 / max 1,6	min 1,9 / max 2,1
W	mm	min 0,45 / max 0,55	min 0,75 / max 0,95	min 1,1 / max 1,4
W _T	mm	min 75 % of W	min 75 % of W	min 75 % of W
T ₁	mm	min 0,1 / max 0,3	min 0,2 / max 0,45	min 0,2 / max 0,5
T ₂	mm	min 0,15 / max 0,3	min 0,2 / max 0,45	min 0,2 / max 0,5
Weight	mg	0,8	1,5	3,2

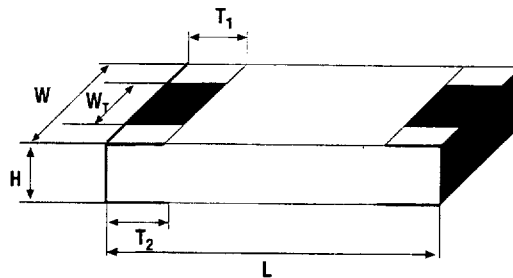

Product Dimensions • Thick Film Chip Resistors

Style	DCS 0402	DCT 0603	DCU 0805	DCA 1206
CECC - Size	RR 0402	RR 0603	RR 0805	RR 1206
EIA - Size	1005	1608	2012	3216
H	mm	min 0,3 / max 0,4	min 0,35 / max 0,55	min 0,45 / max 0,55
L	mm	min 0,95 / max 1,05	min 1,5 / max 1,7	min 1,85 / max 2,15
W	mm	min 0,45 / max 0,55	min 0,75 / max 0,95	min 1,1 / max 1,4
W _T	mm	—	min 0,75 / max 0,95	min 1,1 / max 1,4
T ₁	mm	min 0,1 / max 0,35	min 0,1 / max 0,5	min 0,2 / max 0,6
T ₂	mm	min 0,15 / max 0,35	min 0,1 / max 0,5	min 0,2 / max 0,6
Weight	mg	0,52	2,5	5,5

PCB Layout Recommendations • Reflow Soldering

CECC - Size		0402	0603	0805	1206
EIA - Size		1005	1608	2012	3216
B	mm	0,65	1,0	1,5	1,9
P	mm	0,4	0,5	0,7	1,0
G	mm	0,4	1,0	1,2	1,8
A	mm	1,2	2,0	2,6	3,8

The used soldering process determines the optimum pad size.
The pad size has an influence on the achievable power dissipation.
Alternative recommendations and comprehensive information are given in the American standard IPC-SM-782: Surface Mount Design and Land Pattern Standard.

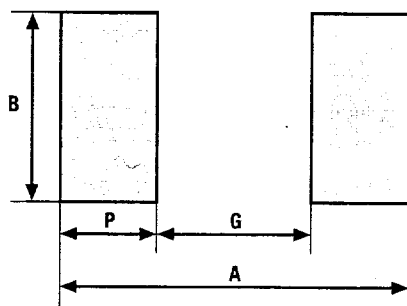

PCB Layout Recommendations • Wave Soldering

CECC - Size		0402	0603	0805	1206
EIA - Size		1005	1608	2012	3216
B	mm	-	1,2	1,6	2,0
P	mm	-	0,6	0,9	1,2
G	mm	-	1,0	1,2	1,8
A	mm	-	2,2	3,0	4,2

The used soldering process determines the optimum pad size.
The pad size has an influence on the achievable power dissipation.
Alternative recommendations and comprehensive information are given in the American standard IPC-SM-782: Surface Mount Design and Land Pattern Standard.

Resistance Coding

Style

MCS 0402	MCT 0603	MCU 0805	
	OCT 0603	OCU 0805	
	NCT 0603	NCU 0805	
DCS 0402	DCT 0603	DCU 0805	DCA 1206
-	E24: 3 digits E96: 4 digits	E24: 3 digits E96: 4 digits	E24: 3 digits E96: 4 digits

Marking of Resistance Values
Coding

According to IEC 60 062

Packaging Information for MFC Series

Style

MCS 0402	MCT 0603	MCU 0805	-
	OCT 0603	OCU 0805	
	NCT 0603	NCU 0805	
	TCT 0603	TCU 0805	
-	1 000	1 000	-
-	5 000	5 000	-
10 000	-	-	-
-	to be announced	to be announced	-

Paper Tape	P1*	pcs.
	* precision only	
Paper Tape	P5	pcs.
Paper Tape	E0	pcs.
Bulk Case	M	pcs.

Packaging Information for DFC Series

Style

Paper Tape	PW	pcs.
Paper Tape	PA	pcs.
Paper Tape	E0	pcs.

DCS 0402	DCT 0603	DCU 0805	DCA 1206
-	20 000	20 000	20 000
-	5 000	5 000	5 000
10 000	-	-	-

Order Code Example

M C T 0603 - 50 1% P5 10 k

Film Type
M = Metal and Cermet
O = High Ohmic
N = Low Ohmic
T = Trimmable
D = Thick Film

Product Type
C = Flat Chip

BEYSCHLAG Style
S = 0402
T = 0603
U = 0805
A = 1206

CECC - Size
RR 0603

Resistance Value
10 kΩ

Packaging
P5 = 5 000 pieces papertape / reel
see packaging information

Tolerance
Nominal Value ± 1%

Temperature Coefficient
0 ± 50 · 10 ⁻⁶ /K

Jumpers are ordered by the resistance value 0 Ω, e.g. **MCT 0603 P5 0R0**.
A temperature coefficient 100 is marked -00, higher T.C. values are not specified.

Introduction
to BEYSCHLAG

Product
Overview

Flat Chip
Resistor Products

MELF
Resistor Products

Leaded
Resistor Products

Resistor Arrays
and Networks

Engineering
Sample Kits

Appendices
and Glossary

Distribution
Network

Reel for MFC Series

Style		MCS 0402	MCT 0603	MCU 0805			
			OCT 0603	OCU 0805			
			NCT 0603	NCU 0805			
			TCT 0603	TCU 0805			
		E0	P1	P5	P1	P5	
A	mm	180	180		180		
E	mm	2,5 ± 0,5				-	
D	mm	22,5 ± 2,0				-	
W ₁	mm	8,4 ^{+1,5} ₀				-	
C	mm	13,0 ^{+0,5} _{-0,25}				-	
N	mm	62				-	
W ₂	mm	max 14,4				-	

According to IEC 60 286-3

Reel for DFC Series

Style		DCS 0402	DCT 0603		DCU 0805		DCA 1206	
		E0	PA	PW	PA	PW	PA	PW
A	mm	180	180	330	180	330	180	330
E	mm	2,5 ± 0,5	2,5 ± 0,5	-	2,5 ± 0,5	-	2,5 ± 0,5	-
D	mm	22,5 ± 2,0	22,5 ± 2,0	20,5	22,5 ± 2,0	20,5	22,5 ± 2,0	20,5
W ₁	mm	8,4 ^{+1,5} ₀						
C	mm	13,0 ^{+0,5} _{-0,25}	13,0 ^{+0,5} _{-0,25}	12,75 ^{+1,5} ₀	13,0 ^{+0,5} _{-0,25}	12,75 ^{+0,15} ₀	13,0 ^{+0,5} _{-0,25}	12,75 ^{+0,15} ₀
N	mm	62						
W ₂	mm	max 14,4						

According to IEC 60 286-3

Introduction to BEYSCHLAG
 Product Overview
 Flat Chip Resistor Products
 MELF Resistor Products
 Leaded Resistor Products
 Resistor Arrays and Networks
 Engineering Sample Kits
 Appendices and Glossary
 Distribution Network



Reel

Introduction to BEYSCHLAG

Product Overview

Flat Chip Resistor Products

MELF Resistor Products

Leaded Resistor Products

Resistor Arrays and Networks

Engineering Sample Kits

Appendices and Glossary

Distribution Network

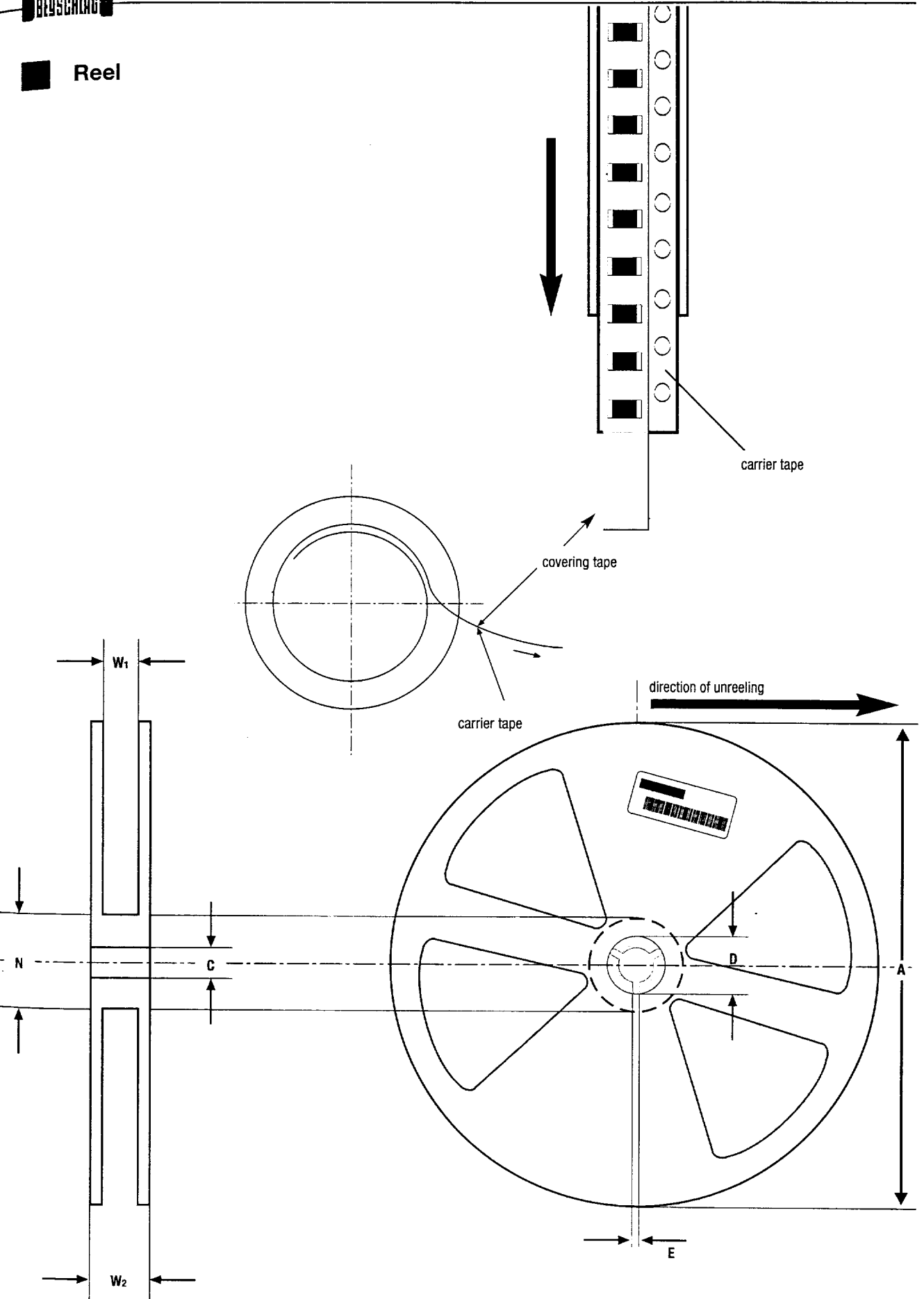

Cardboard Tape

Style	MCS 0402	MCT 0603	MCU 0805	DCS 0402	DCT 0603	DCU 0805	DCA 1206
		OCT 0603	OCU 0805				
		NCT 0603	NCU 0805				
		TCT 0603	TCU 0805				

A₀	mm	0,7	1,1	1,6	0,7	1,0 ^{+0,2} ₀	1,5 ^{+0,2} ₀	1,85 ^{+0,2} ₀
B₀	mm	1,2	1,9	2,38	1,2	1,8 ^{+0,2} ₀	2,25 ^{+0,2} ₀	3,45 ^{+0,2} ₀
E	mm	1,75 ± 0,1						
F	mm	3,5 ± 0,05						
D₀	mm	1,5 ^{+0,1} ₀						
P₀	mm	4,0 ± 0,1						
P₁	mm	2,0	4,0 ± 0,1		2,0	4,0 ± 0,1		
P₂	mm	2,0 ± 0,05						
W	mm	8,0 ± 0,3						

According to IEC 60 286-3 type I

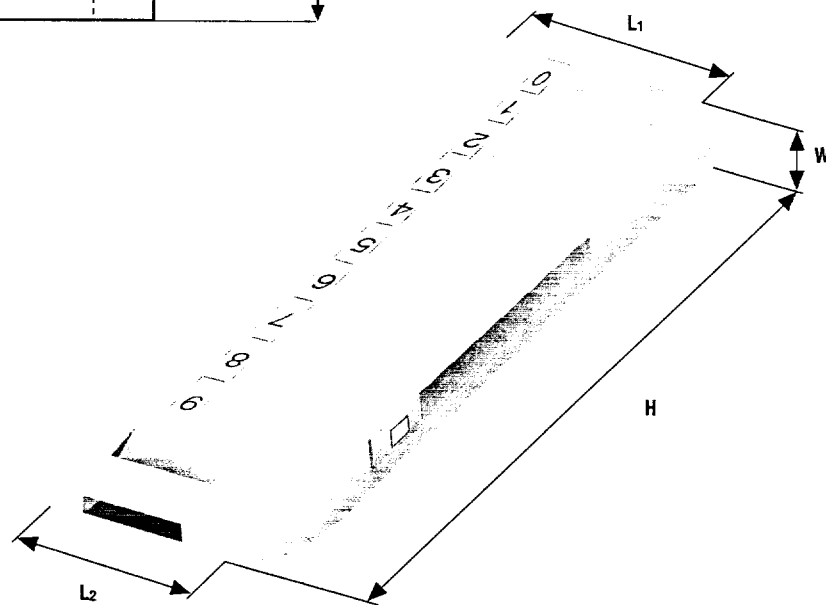
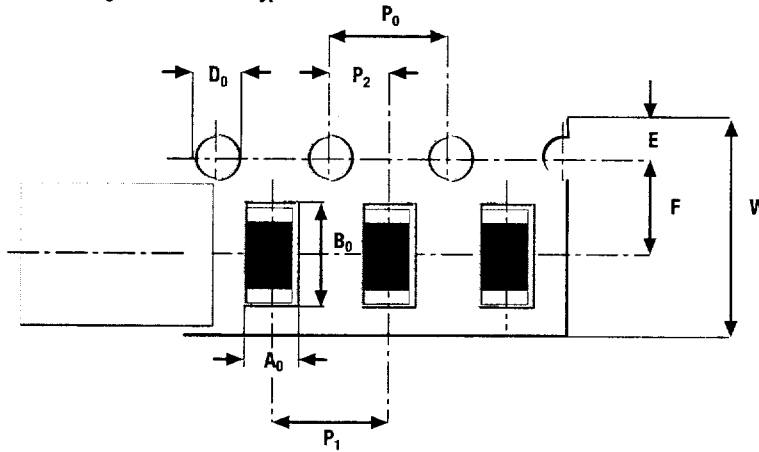

Bulk Case

		MFC Series
L₁	mm	36
H	mm	110
W	mm	12
L₂	mm	31,5

According to IEC 60 286-6

Introduction to BEYSCHLAG
 Product Overview
 Flat Chip Resistor Products
 MELF Resistor Products
 Leaded Resistor Products
 Resistor Arrays and Networks
 Engineering Sample Kits
 Appendices and Glossary
 Distribution Network