

Rating	16A 125V AC 1/3HP 10A 250V AC 1/2HP 16A 125V AC/10A 250V AC CQC T85 10(4)A 250V~			
	Contact Resistance			50m ohm Max.
	Insulation Resistance			DC 500V 100M ohm Min.
	Dielectric Strength			AC 1500V 1 minute
	Operation Temperature			-25°C~85°C
	Switch Function			3P SPDT ON-OFF-ON

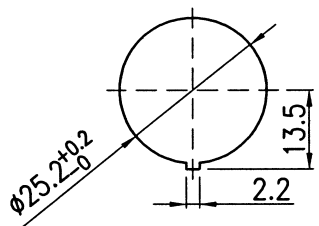
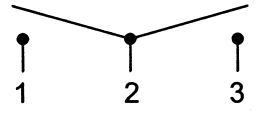
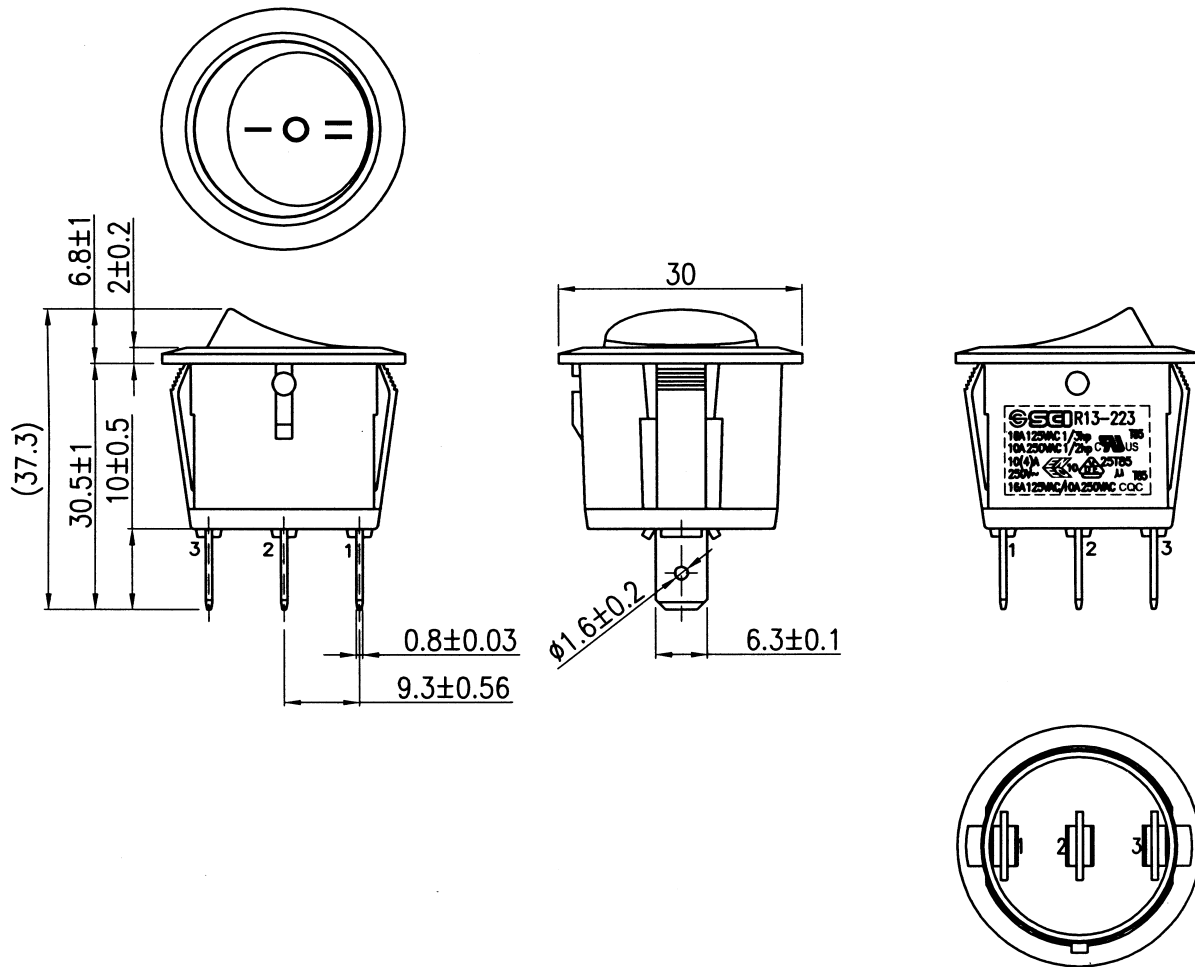

Tolerances ±0.3 Unless Otherwise Specified

						△
						△
Date		Name		Description		No.
Drawn	Checked	Approved	SCI BOM No.	1821404	Model Name	ROCKER SWITCH
雷云飛			Customer No.		Model No.	R13-223D-01
01/03/'13		1/11-13	Unit	mm	Shin Chin Industrial Co., Ltd.	
						Rev. X0