

INTRODUCTION:

SIP Resistor Networks have qualified metal glaze elements on purity ceramic substrates with strong clip construction terminals, and pricing from automated mass production. Special methods coupled with stringent process controls are used in every step of production to insure 'built-in' reliability and consistent quality.

FEATURES:

- Small in size with high precision package It is suitably used in printed circuit.
- Automated machinery mass production and competitive prices accordingly.
- Extremely high stability, accuracy and reliability.

簡介:

精選安定性良好的厚膜電阻材料，將它印刷於瓷
器基板上然後燒成。再經過高速雷射機切出精確
阻值，加插導針後塗裝而成

特性:

- 小形且高密度包裝，適宜印刷電路板使用。
- 自動化大量生產，價格合理實在。
- 高精密製造技術的精品，每一生產階段均有嚴格品管，產品品質穩定、信賴度很高。

DIMENSION:mm

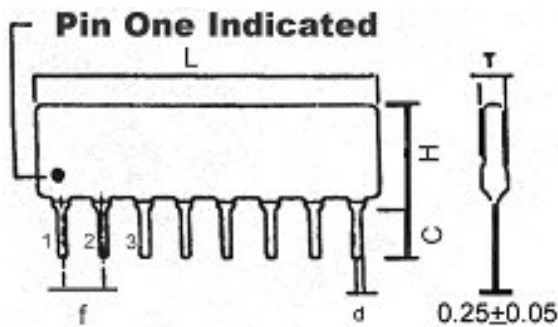

TYPE	L (Max)	H(Max)		T (Max)	C±0.5	d±0.05	f±0.2
		RA	RB				
4pin	10.2	5.08	8	2.5	3.5	0.5	2.54
5pin	12.7						
6pin	15.3						
7pin	17.8						
8pin	20.4						
9pin	22.9						
10pin	25.4						
11pin	28.0						
12pin	30.5						
13pin	33.1						
14pin	35.6						

STANDARD CIRCUITS:

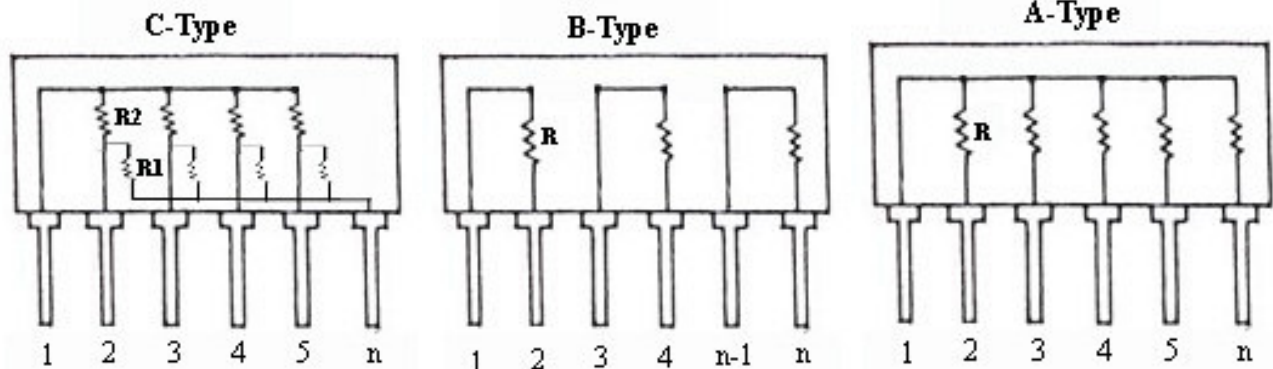

CHARACTERISTIC

ITEM	TEST METHODS	SPECIFICATION
Resistance Temperature Characteristic	-55°C ~ + 125°C	±100ppm/°C for 50 ohm ~ 2.2M ±250ppm/°C for < 50 ohm ≥ 2.2M
Temperature Cycling	-55°C ~ + 125°C, for 5 Cycle	△ R ≤ ± (0.5% + 0.05Ω)
Short-Time Overload	Rated Voltage × 2.5 for 5 sec.	△ R ≤ ± (0.5% + 0.05Ω)
Resistance Soldering Heat	350°C for 3 sec.	△ R ≤ ± (0.5% + 0.05Ω)
Insulation Resistance	100V for 1 minute	△ 10,000 Meg ohm Min.
Terminal Strength	Tensile : 1Kg, 30sec. Bending : 500g 2 Times	△ R ≤ ± (0.25% + 0.05Ω)
Thermal shock	Load V, Room Temp. 30 minute Unload, -55°C, 15 minute Over 2 hrs in Room Temp. before measuring	△ R ≤ ± (0.5% + 0.05Ω)
Solderbility	230°C±5°C, 3 sec.	Covering 95%
Moisture Load Life	40°C, 90-95% RH rated Voltage for 1000 hours	△ R ≤ ± (2% + 0.05Ω)
Load Life	70°C at Rated Voltage for 1000 hours	△ R ≤ ± (2% + 0.05Ω)

STANDARD RESISTANCE (OHM) E-12 SERIES

10	12	15	18	22	27	33	39	47	56	68	82
100	120	150	180	220	270	330	390	470	560	680	820
1K	1.2K	1.5K	1.8K	2.2K	2.7K	3.3K	3.9K	4.7K	5.6K	6.8K	8.2K
10K	12K	15K	18K	22K	27K	33K	39K	47K	56K	68K	82K
100K	120K	150K	180K	220K	270K	330K	390K	470K	560K	680K	820K
1M	1.2M	1.5M	1.8M	2.2M							

DERATING CURVE

DUAL TERMINATORS (R1/R2) (OHM)

160/240	330/390
180/390	330/470
220/270	1.5K/3.3K
220/330	3.0K/6.2K

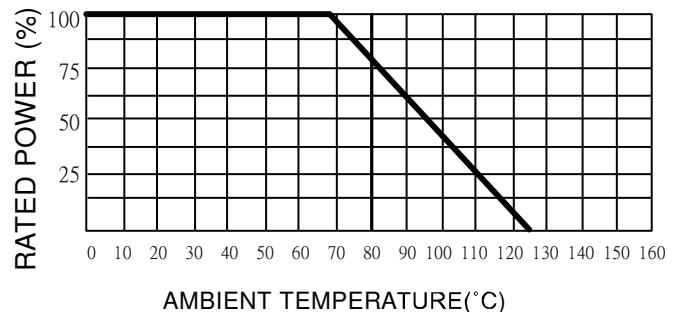

HOW TO ORDER

RA	A	08	472	J
SERIEC	CIRCUITE	NUMBER OF PIN	RESISTANCE	TOLERANCE
RA=LOW Profile RB=HIGH Power	A STYLE B C D E P R T	04 = 4 PIN 05 = 5 PIN 06 = 6 PIN 07 = 7 PIN 08 = 8 PIN 09 = 9 PIN 10 = 10 PIN 11 = 11 PIN 12 = 12 PIN 13 = 13 PIN 14 = 14 PIN	22Ω = 220 100Ω = 101 1000Ω = 102 10KΩ = 103 1MΩ = 105	F = ± 1 % G = ± 2 % J = ± 5 %