

# SURFACE MOUNT ALUMINUM ELECTROLYTIC CAPACITORS



UPGRADE

**SC** Chip type, Standard Series

**S**  
Solvent Proof  
WV ≤ 100V

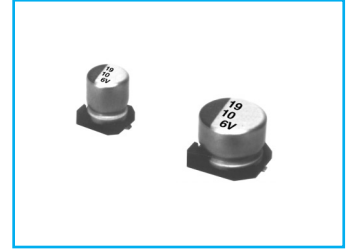

- Chip type higher capacitance in larger case size
- Designed for surface mounting on high density PC board
- Applicable to automatic insertion machine using carrier tape
- Complied to the RoHS directive



Item	Characteristics																											
Operating temperature range	-40 ~ +85°C																											
Leakage current max.	WV ≤ 100 I = 0.01CV or 3μA whichever is greater (after 2 minutes) WV ≥ 160 I = 0.04CV + 100μA(after 1 minutes)																											
Capacitance tolerance	±20% at 120Hz, 20°C																											
Dissipation factor max. (at 120Hz, 20°C)	<table border="1"> <tr> <td>WV</td> <td>4</td> <td>6.3</td> <td>10</td> <td>16</td> <td>25</td> <td>35</td> <td>50</td> </tr> <tr> <td>tanδ</td> <td>0.35 (0.40)</td> <td>0.28 (0.35)</td> <td>0.20 (0.24)</td> <td>0.16 (0.20)</td> <td>0.13 (0.16)</td> <td>0.12 (0.15)</td> <td>0.09 (0.12)</td> </tr> </table>	WV	4	6.3	10	16	25	35	50	tanδ	0.35 (0.40)	0.28 (0.35)	0.20 (0.24)	0.16 (0.20)	0.13 (0.16)	0.12 (0.15)	0.09 (0.12)											
	WV	4	6.3	10	16	25	35	50																				
	tanδ	0.35 (0.40)	0.28 (0.35)	0.20 (0.24)	0.16 (0.20)	0.13 (0.16)	0.12 (0.15)	0.09 (0.12)																				
<table border="1"> <tr> <td>WV</td> <td>63</td> <td>100</td> <td>160</td> <td>200</td> <td>250</td> <td>400</td> <td>450</td> </tr> <tr> <td>tanδ</td> <td>0.12</td> <td>0.12</td> <td>0.20</td> <td>0.20</td> <td>0.20</td> <td>0.25</td> <td>0.25</td> </tr> </table>	WV	63	100	160	200	250	400	450	tanδ	0.12	0.12	0.20	0.20	0.20	0.25	0.25												
WV	63	100	160	200	250	400	450																					
tanδ	0.12	0.12	0.20	0.20	0.20	0.25	0.25																					
Figures in( ) are for small size, over the 6.3 × 5.8(φ D × L)																												
Low temperature characteristics (Impedance ratio at 120Hz)	<table border="1"> <tr> <td>WV</td> <td>4</td> <td>6.3</td> <td>10</td> <td>16</td> <td>25</td> <td>35 ~ 100</td> <td>160 ~ 250</td> <td>400 ~ 450</td> </tr> <tr> <td>Z-25°C/Z+20°C</td> <td>6</td> <td>5</td> <td>4</td> <td>3</td> <td>2</td> <td>2</td> <td>3</td> <td>6</td> </tr> <tr> <td>Z-40°C/Z+20°C</td> <td>12</td> <td>10</td> <td>8</td> <td>6</td> <td>4</td> <td>3</td> <td>6</td> <td>10</td> </tr> </table>	WV	4	6.3	10	16	25	35 ~ 100	160 ~ 250	400 ~ 450	Z-25°C/Z+20°C	6	5	4	3	2	2	3	6	Z-40°C/Z+20°C	12	10	8	6	4	3	6	10
	WV	4	6.3	10	16	25	35 ~ 100	160 ~ 250	400 ~ 450																			
	Z-25°C/Z+20°C	6	5	4	3	2	2	3	6																			
Z-40°C/Z+20°C	12	10	8	6	4	3	6	10																				
Load life (after application of the rated voltage for 2000 hours at 85°C)	Leakage current	Less than specified value																										
	Capacitance change	Within ±20% of initial value (Small size : ±25%)																										
	tanδ	Less than 200% of specified value																										
Shelf life (at 85°C)	After 1000 hours no load test, leakage current, capacitance and tanδ are same as load life value.																											
Resistance to soldering heat	The following specifications shall be satisfied when the capacitors are restored to 20°C after exposing them at 250°C for 30 seconds.																											
	Leakage current	Less than specified value																										
	Capacitance change	Within ±10% of initial value																										
	tanδ	Less than specified value																										

CHIP TYPES

## DRAWING

Unit : mm

(φ 4, φ 5, φ 6.3 × 5.3mmL)

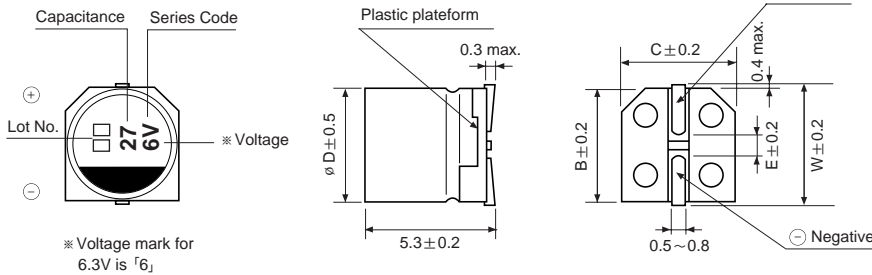

φ D × L	W	A	B	C	E	R
4 × 5.3	4.8		4.3	4.3	1.0	0.5~0.8
5 × 5.3	6.0		5.3	5.3	1.4	0.5~0.8
6.3 × 5.3	7.1		6.6	6.6	2.2	0.5~0.8
6.3 × 5.8		2.4	6.6	6.6	2.2	0.5~0.8
6.3 × 7.7		2.4	6.6	6.6	2.2	0.5~0.8
8 × 6.2		3.3	8.3	8.3	2.3	0.5~0.8
8 × 10		2.9	8.3	8.3	3.1	0.8~1.1
10 × 10		3.2	10.3	10.3	4.5	0.8~1.1
12.5 × 13.5		4.6	12.8	12.8	4.5	1.1~1.4

(φ 6.3, φ 8 × 6.2)

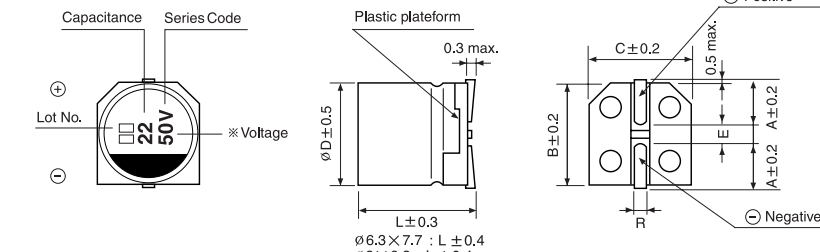

(φ 12.5 × 13.5mmL)

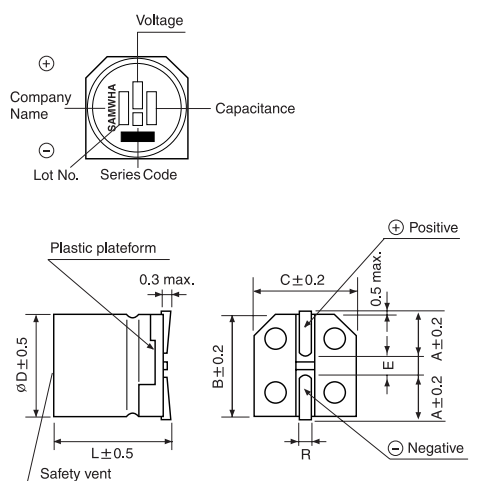

(φ 8 × 10, φ 10 × 10)

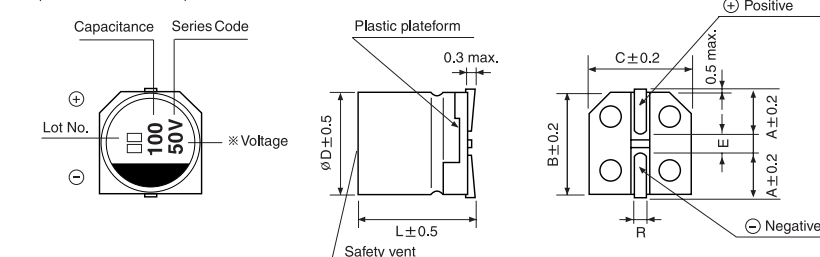

# SURFACE MOUNT ALUMINUM ELECTROLYTIC CAPACITORS



## ● DIMENSIONS & MAXIMUM PERMISSIBLE RIPPLE CURRENT

μF \ WV	4		6.3		10		16		25		35		50		
0.1													3×5.3	2.4	
													4×5.3	3.2	
0.22													3×5.3	3.5	
													4×5.3	4.7	
0.33													3×5.3	4.3	
													4×5.3	5.7	
0.47													3×5.3	5.2	
													4×5.3	6.8	
1.0													3×5.3	7.5	
													4×5.3	10	
2.2												3×5.3	10		
												4×5.3	11	4×5.3	15
3.3										3×5.3	12				
										4×5.3	15	4×5.3	16	4×5.3	18
4.7								3×5.3	13					4×5.3	24
								4×5.3	16	4×5.3	18	4×5.3	19	5×5.3	25
10	3×5.3	13	3×5.3	16	4×5.3	21	4×5.3	21	4×5.3	24	4×5.3	27	5×5.3	41	
	4×5.3	16	4×5.3	19					5×5.3	30	5×5.3	32	6.3×5.3	43	
22	3×5.3	19	4×5.3	29	4×5.3	28	4×5.3	30	5×5.3	41	6.3×5.3	55	6.3×5.3	71	
	4×5.3	24			5×5.3	36	5×5.3	41	6.3×5.3	53			6.3×5.8	73	
33	4×5.3	29	4×5.3	30	4×5.3	34	5×5.3	43	5×5.3	50	6.3×5.3	65	6.3×5.8	94	
			5×5.3	41	5×5.3	44	6.3×5.3	58	6.3×5.3	64	6.3×5.3	67	8×6.2	95	
47	4×5.3	35	4×5.3	36	5×5.3	47	5×5.3	52	6.3×5.3	70	6.3×7.7	94	6.3×7.7	105	
			5×5.3	48	6.3×5.3	62	6.3×5.3	69	6.3×5.8	72	8×6.2	105	8×10	140	
100	5×5.3	54	5×5.3	60	6.3×5.3	80	6.3×5.3	88	8×6.2	145	6.3×7.7	132	8×10	181	
	6.3×5.3	68	6.3×5.8	82	6.3×5.8	82	6.3×5.8	91			8×10	175	10×10	195	
220	6.3×5.3	93	6.3×5.8	91	6.3×7.7	173	6.3×7.7	162	8×10	232	10×10	265	10×10	320	
					8×6.2	175	8×10	215	10×10	250					
330			6.3×7.7	188	8×10	240	8×10	270	10×10	305	10×10	360	12.5×13.5	600	
			8×6.2	190											
470			8×10	265	8×10	290	8×10	307	10×10	400	12.5×13.5	600			
							10×10	330							
1000			8×10	370	10×10	454	12.5×13.5	710	12.5×13.5	820					
			10×10	400											
1500			10×10	480	12.5×13.5	850									
2200			12.5×13.5	890	12.5×13.5	960									

μF \ WV	63		100		160		200		250		400		450		
2.2													10×10	85	
3.3			6.3×5.8	29							10×10	90	10×10	100	
4.7	6.3×5.8	31	6.3×5.8	35			10×10	100	10×10	100	12.5×13.5	115	12.5×13.5	115	
			8×6.2	40											
10	8×5.8	46	8×10	77	10×10	100	12.5×13.5	150	12.5×13.5	150					
22	8×6.2	96	8×10	100	12.5×13.5	240	12.5×13.5	260							
33	8×10	117	10×10	130	12.5×13.5	260	← Ripple current (mA rms) at 85°C, 120Hz								
47	10×10	140	10×10	155	—— Case size ∅ D×L (mm)										
68	10×10	160	12.5×13.5	350											
100	12.5×13.5	370													