

RC Chip type, Wide Temperature Range Series

- Wide operating temperature range of -55 ~ +105°C
- Designed for surface mounting on high density PC board
- Applicable to automatic insertion machine using carrier tape
- Complied to the RoHS directive



Item	Characteristics						
Operating temperature range	-55 ~ +105°C						
Leakage current max.	I = 0.01CV or 3μA whichever is greater (after 2 minutes)						
Capacitance tolerance	±20% at 120Hz, 20°C						
Dissipation factor max. (at 120Hz, 20°C)	WV	6.3	10	16	25	35	50
	tanδ	0.27	0.23	0.19	0.15	0.13	0.11
Low temperature characteristics (Impedance ratio at 120Hz)	WV	6.3	10	16	25	35	50
	Z-25°C/Z+20°C	3	3	2	2	2	2
	Z-40°C/Z+20°C	8	5	4	3	3	3
Load life (after application of the rated voltage for 1000 hours at 105°C)	Leakage current	Less than specified value					
	Capacitance change	Within ±25% of initial value					
	tanδ	Less than 200% of specified value					
Shelf life (at 105°C)	After 1000 hours no load test, leakage current, capacitance and tanδ are same as load life value.						
Resistance to soldering heat	The following specifications shall be satisfied when the capacitors are restored to 20°C after exposing them at 250°C for 30 seconds.						
	Leakage current	Less than specified value					
	Capacitance change	Within ±10% of initial value					
	tanδ	Less than specified value					

DRAWING

Unit : mm

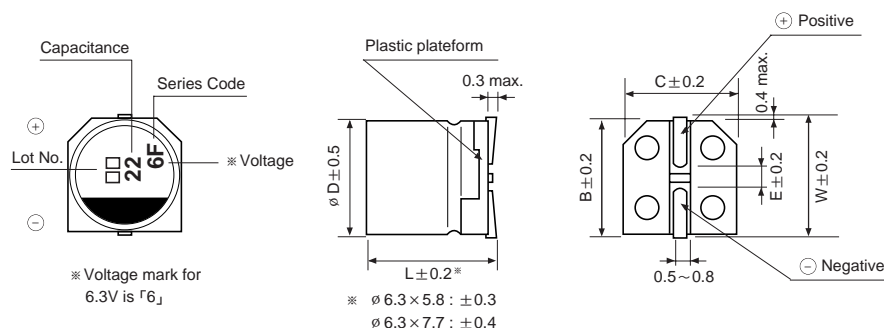

∅ D	W	B	C	E
4	4.8	4.3	4.3	1.0
5	6.0	5.3	5.3	1.4
6.3	7.1	6.6	6.6	2.2

* ∅ 8, 10 Drawing See Page 35

DIMENSIONS & MAXIMUM PERMISSIBLE RIPPLE CURRENT

μF	WV	6.3	10	16	25	35	50
0.1							4 × 5.3 2.3
0.22							4 × 5.3 3.4
0.33							4 × 5.3 4.1
0.47							4 × 5.3 4.9
1.0							4 × 5.3 7.2
2.2							4 × 5.3 10.7
3.3							4 × 5.3 13.1
4.7					4 × 5.3 13	4 × 5.3 14	5 × 5.3 18.1
10				4 × 5.3 17	5 × 5.3 23	5 × 5.3 24	6.3 × 5.3 30.8
22	4 × 5.3 22	5 × 5.3 27	5 × 5.3 30	6.3 × 5.3 39	6.3 × 5.3 42	6.3 × 5.8 45	6.3 × 7.7 60
33	5 × 5.3 31	5 × 5.3 33	6.3 × 5.3 43	6.3 × 5.3 48	6.3 × 5.8 52	6.3 × 7.7 60	
47	5 × 5.3 36	6.3 × 5.3 46	6.3 × 5.3 51	6.3 × 5.8 59	6.3 × 5.8 63	6.3 × 7.7 63	
100	6.3 × 5.3 50	6.3 × 5.8 64	6.3 × 5.8 64	6.3 × 7.7 91	8 × 10 296	10 × 10 295	
220	6.3 × 7.7 86	6.3 × 7.7 105	6.3 × 7.7 105	8 × 10 340	10 × 10 435		
330	6.3 × 7.7 105	8 × 10 305	8 × 10 425	10 × 10 360			
470	8 × 10 330	10 × 10 340	10 × 10 470				
1000	10 × 10 475						

↑ ↑ Ripple current (mA rms) at 105°C, 120Hz
Case size ∅ D × L (mm)