

Top View of Assembly

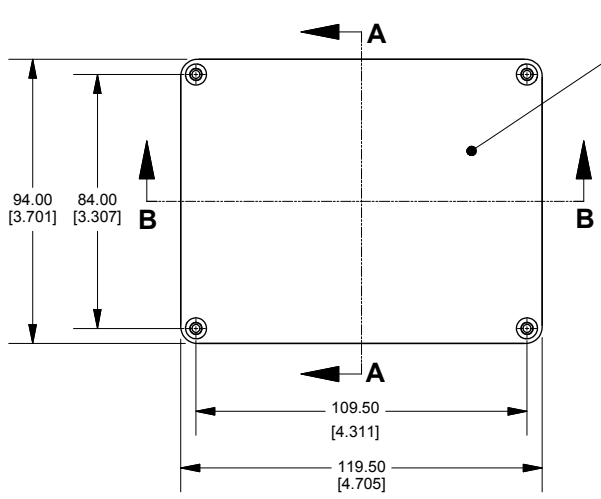

SECTION A-A
End View of Assembly

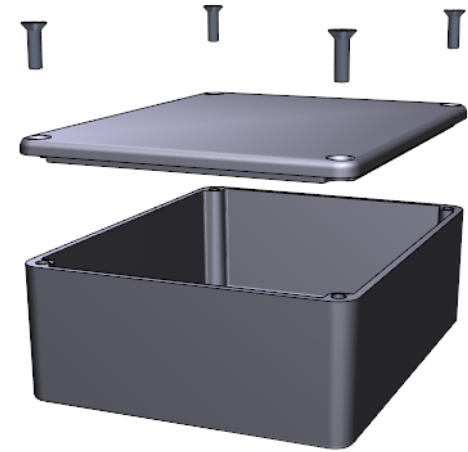
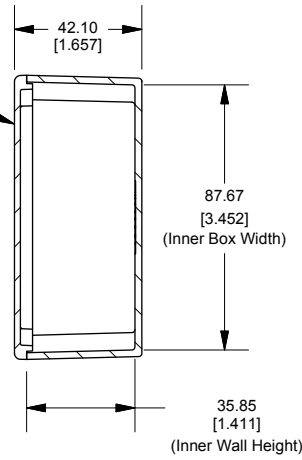

Top View Looking Inside Box

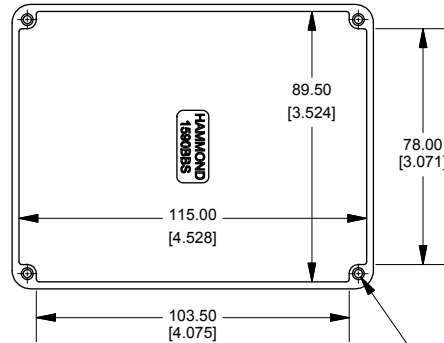

SECTION B-B
Side View of Assembly

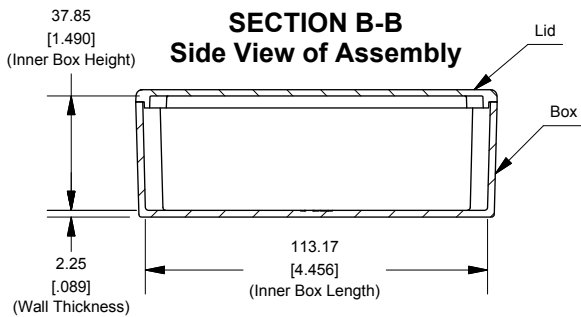

Lid

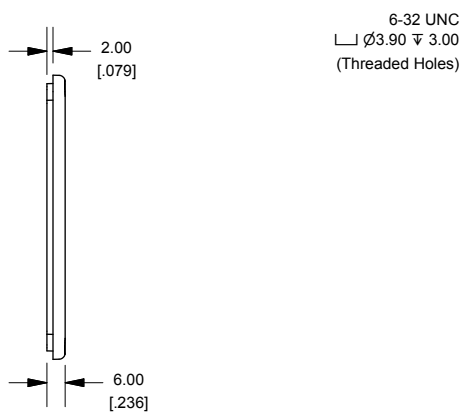
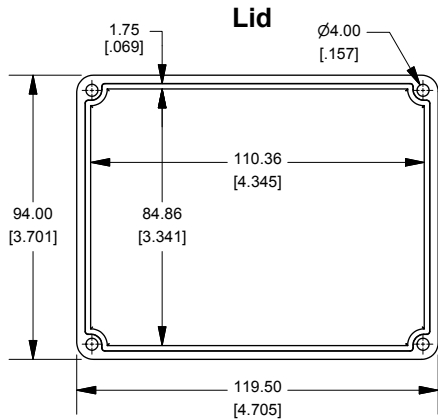

Enclosures can be Factory Modified (Milling, Drilling, Printing etc.)
 Contact Factory mjm@hammondmfg.com for quotes
 Solid models of this enclosure available in STEP or IGES.

NOTE	
Purchased assembly includes box, lid and 4 cover screws. Box and lid are made from Diecast Aluminum Alloy (alloy type 380). Silicone gasket supplied with liquid resistant enclosures.	
PART NUMBERS	
1590BBS Enclosure	
Unfinished	1590BBS
G Black Textured Polyester Powder Paint - RAL 9011	1590BBSBK
1590BBS Liquid Resistant Enclosure (Silicone Gasket)	
Unfinished	1590WBBS
Black Textured Powder Paint	1590WBBSBK
ACCESSORIES	
Recommended Torque: 75 ozf.in / 55 cN.m	
Black Textured Cover Screws (Pkg 100) [6-32 x 1/2" SS Type 304]	1590WMS100BK
Unfinished Cover Screws (Pkg 100) [6-32 x 1/2" SS Type 304]	1590WMS100
Standard Cover Screws	
Unfinished Cover Screws (Pkg 100) [6-32 x 1/2" Nickel Plated Screws]	1590MS100
Black Textured Cover Screws (Pkg 100) [6-32 x 1/2" Nickel Plated Screws]	1590MS100BK

**HAMMOND
MANUFACTURING™**

1590BBS

www.hammondmfg.com