

Power Resistor Thick Film Technology

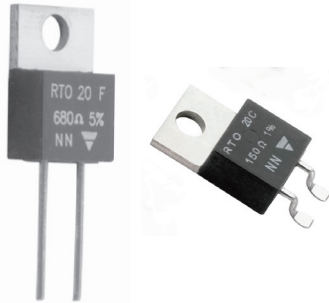

The well known TO 220 package is compact and easy to mount.

DIMENSIONS in millimeters

RTO 20F - LEADED

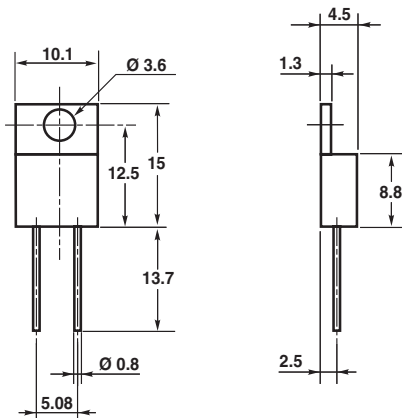

RTO 20C - FOR SURFACE MOUNTING

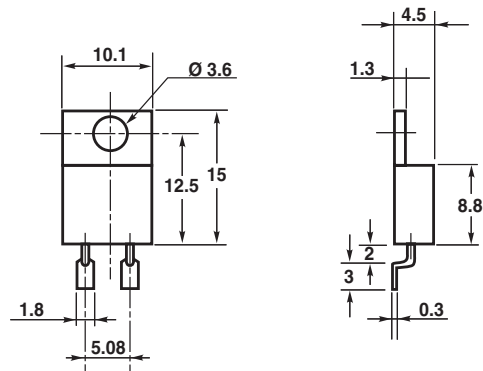

• Tolerance unless otherwise specified: ± 0.4mm

MECHANICAL SPECIFICATIONS

Mechanical Protection	Insulated Case
Resistive Element	Thick Film
Connections	Tinned copper
Weight	2g max.

DIMENSIONS

Standard Package	TO 220 Insulated case
------------------	--------------------------

ENVIRONMENTAL SPECIFICATIONS

Temperature Range	- 55°C to + 155°C
Climatic Category	55/155/56
Sealing	Sealed container Solder immersion

ELECTRICAL SPECIFICATIONS

Resistance Range	0.010Ω to 1MΩ
Tolerances (Standard)	± 1% to ± 10%
Dissipation and Associated:	Onto a heatsink
Thermal Resistance and Nominal Power	20W at + 25°C R _{TH} (j-c): 6.5°C/W free air: 2W at + 25°C
Temperature Coefficient	See Performance table
Standard	± 150ppm/°C
Limiting Element Voltage	250V
Dielectric Strength MIL STD 202	2000V _{RMS} - 1 minute - 10mA Max (Between Terminals and Heatsink)
Insulation Resistance	≥ 10 ⁶ MΩ
Inductance	≤ 0.1 μH
Critical Resistance	3.12 kΩ



PERFORMANCE		
TESTS	CONDITIONS	TYPICAL DRIFTS
Momentary Overload	NF EN 140000 CEI 115_1 2Pr/5s Us < 1.5UL	± (0.25% + 0.005Ω)
Rapid Temperature Change	NF EN 140000 CEI 68214 Test Na 5 cycles - 55°C to + 135°C	± (0.5% + 0.005Ω)
Load Life	NF EN 140000 CEI 115_1 1000h Pr at + 25°C	± (1% + 0.005Ω)
Humidity (Steady State)	NF EN 140000 56 days R.H. 95%	± (0.5% + 0.005Ω)
High Temperature Exposure	NF EN 140000 1000h - 40% Pr at + 100°C	± (0.5% + 0.005Ω)
Vibration	MIL STD 202, Method 204 C Test D	± (0.2% + 0.005Ω)
Terminal Strength	MIL STD 202, Method 211 Test A1	± (0.2% + 0.005Ω)

SPECIAL FEATURES				
Resistance Values	≥ 0.01	≥ 0.015	≥ 0.1	≥ 0.5
Tolerances	± 1% at ± 10%			
Typical Temperature Coefficient (- 55°C/+ 155°C) range	± 900ppm/°C	± 700ppm/°C	± 250ppm/°C	± 150ppm/°C

Note: For very low ohmic values, TC for information

CHOICE OF THE HEATSINK

The user must choose according to the working conditions of the component (power, room temperature).

Maximum working temperature must not exceed 155°C. The dissipated power is simply calculated by the following ratio:

$$P = \frac{\Delta T}{[R_{TH} (j-c) + R_{TH} (c-a)]} \quad (1)$$

P: expressed in W

ΔT: difference between maximum working temperature and room temperature.

R_{TH} (j-c): thermal resistance value measured between resistive layer and outer side of the resistor. It is the thermal resistance of the component: (Special Features Table)

R_{TH} (c-a): thermal resistance value measured between outer side of the resistor and room temperature. It is the thermal resistance of the heatsink itself (type, shape) and the quality of the fastening device.

Example:

R_{TH} (c-a) for RTO 20 power rating 10W at ambient temperature + 25°C.

Thermal resistance R_{TH} (j-c): 6.5°C/W

Considering equation (1) we have:

$$\Delta T = 155^\circ\text{C} - 25^\circ\text{C} = 130^\circ\text{C}$$

$$R_{TH} (j-c) + R_{TH} (c-a) = \frac{\Delta T}{P} = \frac{130}{10} = 13^\circ\text{C/W}$$

$$R_{TH} (c-a) = 13^\circ\text{C/W} - 6.5^\circ\text{C/W} = 6.5^\circ\text{C/W}$$



OVERLOADS

In any case the applied voltage must be lower than the maximum overload voltage of 375V.

The values indicated on the graph below are applicable to resistors in air or mounted onto a heatsink.

ENERGY CURVE

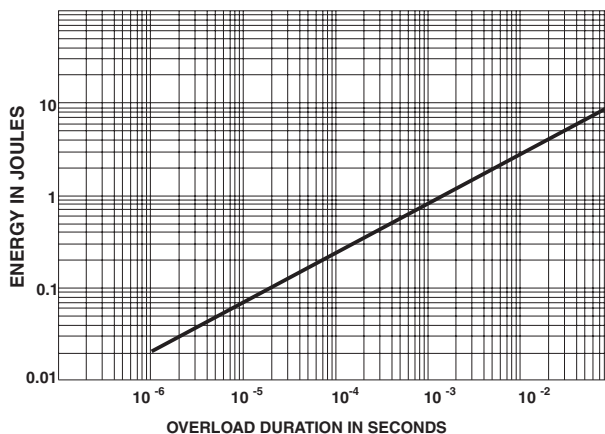

POWER RATING CHART

The temperature of the heatsink should be maintained within the limits specified.

To improve the thermal conductivity, surfaces in contact should be coated with a silicone grease and the torque applied on the screw for tightening should be around 1Nm.

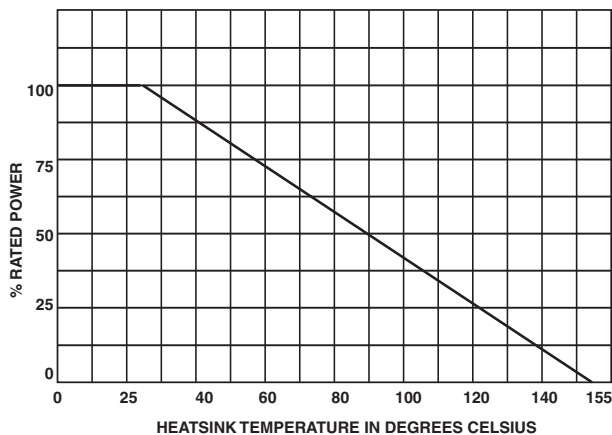

MARKING

Model, Style, Resistance Value (in Ω), Tolerance (in %), Manufacturing Date, VISHAY trademark.

PACKAGING	
Tube of 50 units	

ORDERING INFORMATION					
RTO MODEL	20 STYLE	F CONNECTIONS	100k RESISTANCE VALUE	± 10% TOLERANCE	xxx CUSTOM DESIGN
		F: Radial Leads C: Surface Mount		± 1% ± 2% ± 5% ± 10%	Optional on request: special TCR, shape etc.