

Thin Film Precision Chip Resistor (AR Series)

■ Features

- Advanced thin film technology
- Very tight tolerance down to $\pm 0.01\%$
- Extremely low TCR down to $\pm 5\text{PPM}/^\circ\text{C}$
- Wide resistance range 1ohm ~ 3Mega ohm
- Miniature size 0201 available

■ Applications

- Medical Equipment
- Testing / Measurement Equipment
- Printer Equipment
- Automatic Equipment Controller
- Converters
- Communication Device, Cell Phone, GPS, PDA



■ Construction

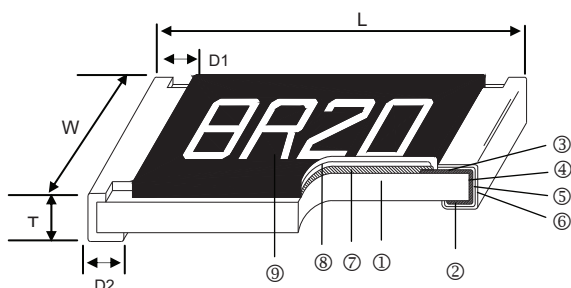

① Alumina Substrate	③ Edge Electrode (NiCr)	⑤ Resistor Layer (NiCr)
② Bottom Electrode (Ag)	④ Barrier Layer (Ni)	⑥ Overcoat (Epoxy)
③ Top Electrode (Ag-Pd)	⑥ External Electrode (Sn)	⑨ Marking

■ Dimensions

Unit: mm

Type	Size (Inch)	L	W	T	D1	D2	Weight (g) (1000pcs)
AR01	0201	0.58 \pm 0.05	0.29 \pm 0.05	0.23 \pm 0.05	0.12 \pm 0.05	0.15 \pm 0.05	0.14
AR02	0402	1.00 \pm 0.05	0.50 \pm 0.05	0.30 \pm 0.05	0.20 \pm 0.10	0.20 \pm 0.10	0.54
AR03	0603	1.55 \pm 0.10	0.80 \pm 0.10	0.45 \pm 0.10	0.30 \pm 0.20	0.30 \pm 0.20	1.83
AR05	0805	2.00 \pm 0.15	1.25 \pm 0.15	0.55 \pm 0.10	0.30 \pm 0.20	0.40 \pm 0.25	4.71
AR06	1206	3.05 \pm 0.15	1.55 \pm 0.15	0.55 \pm 0.10	0.42 \pm 0.20	0.35 \pm 0.25	9.02
AR13	1210	3.10 \pm 0.15	2.40 \pm 0.15	0.55 \pm 0.10	0.40 \pm 0.20	0.55 \pm 0.25	10
AR10	2010	4.90 \pm 0.15	2.40 \pm 0.15	0.55 \pm 0.10	0.60 \pm 0.30	0.50 \pm 0.25	23.61
AR12	2512	6.30 \pm 0.15	3.10 \pm 0.15	0.55 \pm 0.10	0.60 \pm 0.30	0.50 \pm 0.25	38.06

Part Numbering

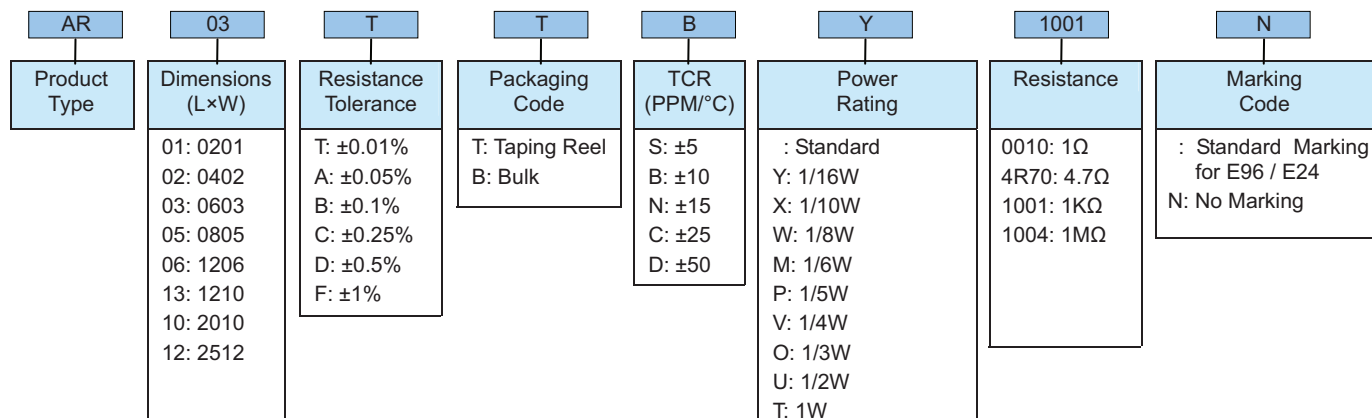

Derating Curve

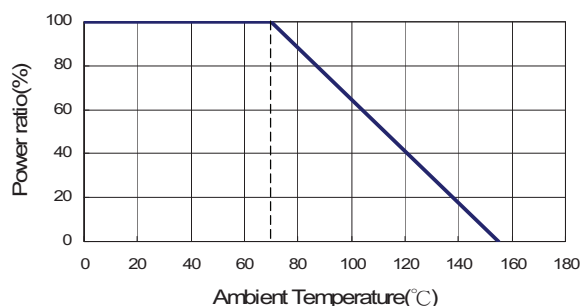

Standard Electrical Specifications

Item Type	Power Rating at 70°C	Operating Temp. Range	Max. Operating Voltage	Max. Overload Voltage	Resistance Range					TCR (PPM/°C)
					±0.05%	±0.1%	±0.25%	±0.5%	±1%	
AR01 (0201)	1/32W	-55 ~ +155°C	15V	30V	—					±25 ±50
AR02 (0402)	1/16W	-55 ~ +155°C	25V	50V	10Ω - 205KΩ					±25 ±50
AR03 (0603)	1/16W	-55 ~ +155°C	50V	100V	4.7Ω - 332KΩ	4.7Ω - 1MΩ	2Ω - 1MΩ		±25 ±50	
AR05 (0805)	1/10W	-55 ~ +155°C	100V	200V	4.7Ω - 511KΩ	4.7Ω - 2MΩ	1Ω - 2MΩ		±25 ±50	
AR06 (1206)	1/8W	-55 ~ +155°C	150V	300V	4.7Ω - 1MΩ	4.7Ω - 2.5MΩ	1Ω - 2.5MΩ		±25 ±50	
AR13 (1210)	1/5W	-55 ~ +155°C	150V	300V	4.7Ω - 1MΩ	4.7Ω - 2.5MΩ	1Ω - 2.5MΩ		±25 ±50	
AR10 (2010)	1/4W	-55 ~ +155°C	150V	300V	4.7Ω - 1MΩ	4.7Ω - 3MΩ	1Ω - 3MΩ		±25 ±50	
AR12 (2512)	1/2W									

Operating Voltage = $\sqrt{P \cdot R}$ or Max. operating voltage listed above, whichever is lower.

Overload Voltage = $2.5 \cdot \sqrt{P \cdot R}$ or Max. overload voltage listed above, whichever is lower.

■ Viking is capable of manufacturing the optional spec based on customer's requirement.

■ Lower Resistance: 1~10Ω

Special Electrical Specifications

Item Type	Power Rating at 70°C	Operating Temp. Range	Max. Operating Voltage	Max. Overload Voltage	Resistance Range			TCR (PPM/°C)
					±0.01%	±0.05%	±0.1%	
AR02 (0402)	1/16W	-55 ~ +155°C	25V	50V	49.9Ω - 5KΩ			±5
					49.9Ω - 12KΩ			±10 ±15
					—	49.9Ω - 70KΩ		±15
AR03 (0603)	1/16W	-55 ~ +155°C	50V	100V	24.9Ω - 15KΩ			±5
					24.9Ω - 100KΩ			±10
					—	4.7Ω - 332KΩ		±15
AR05 (0805)	1/10W	-55 ~ +155°C	100V	200V	24.9Ω - 30KΩ			±5
					24.9Ω - 200KΩ			±10
					—	4.7Ω - 511KΩ		±15
AR06 (1206)	1/8W	-55 ~ +155°C	150V	300V	24.9Ω - 50KΩ			±5
					24.9Ω - 500KΩ			±10
					—	4.7Ω - 1MΩ		±15
AR13 (1210)	1/ 5W	-55 ~ +155°C	150V	300V	24.9Ω - 50KΩ			±5
					24.9Ω - 500KΩ			±10
					—	4.7Ω - 1MΩ		±15
AR10 (2010)	1/4W	-55 ~ +155°C	150V	300V	24.9Ω - 100KΩ			±5
					24.9Ω - 500KΩ			±10
					—	4.7Ω - 1MΩ		±15
AR12 (2512)	1/2W	-55 ~ +155°C	150V	300V	24.9Ω - 100KΩ			±5
					24.9Ω - 500KΩ			±10
					—	4.7Ω - 1MΩ		±15

Operating Voltage= $\sqrt{P \cdot R}$ or Max. operating voltage listed above, whichever is lower.

Overload Voltage= $2.5 \cdot \sqrt{P \cdot R}$ or Max. overload voltage listed above, whichever is lower.

High Power Rating Electrical Specifications

Item Type	Power Rating at 70°C	Operating Temp. Range	Max. Operating Voltage	Max. Overload Voltage	Resistance Range					TCR (PPM/°C)	
					±0.01%	±0.05%	±0.1%	±0.25%	±0.5%		
AR03 (0603)	1/10W	-55 ~ +155°C	75V	150V	24.9Ω - 15KΩ					±5	
					24.9Ω - 100KΩ	4.7Ω - 332KΩ					±10 ±15 ±25 ±50
	1/6W	-55 ~ +155°C	100V	150V	—	100Ω - 332KΩ				±25 ±50	
AR05 (0805)	1/8W	-55 ~ +155°C	150V	300V	24.9Ω - 30KΩ					±5	
					24.9Ω - 200KΩ	4.7Ω - 511KΩ					±10 ±15 ±25 ±50
					—	4.7Ω - 1MΩ					±15 ±25 ±50
					1/4W	-55 ~ +155°C	150V	300V	—	100Ω - 500KΩ	
AR06 (1206)	1/4W	-55 ~ +155°C	200V	400V	24.9Ω - 50KΩ					±5	
					24.9Ω - 500KΩ	4.7Ω - 1MΩ					±10 ±15 ±25 ±50
					1/3W	-55 ~ +155°C	200V	400V	—	100Ω ~ 1MΩ	
AR13 (1210)	1/ 3W	-55 ~ +155°C	200V	400V	24.9Ω - 50KΩ					±5	
					24.9Ω - 500KΩ	4.7Ω - 1MΩ					±10 ±15 ±25 ±50

Operating Voltage= $\sqrt{P \cdot R}$ or Max. operating voltage listed above, whichever is lower.

Overload Voltage= $2.5 \cdot \sqrt{P \cdot R}$ or Max. overload voltage listed above, whichever is lower.

■Viking is capable of manufacturing the optional spec based on customer's requirement.

■Lower Resistance:1~10Ω ; High Power Rating

Environmental Characteristics

Item	Requirement		Test Method
	Tol. \leq 0.05%	Tol. $>$ 0.05%	
Temperature Coefficient of Resistance (T.C.R.)	As Spec.		MIL-STD-202F Method 304 +25/-55/+25/+125/+25°C
Short Time Overload	$\Delta R \pm 0.05\%$	$\Delta R \pm 0.2\%$	JIS-C-5201-1 5.5 RCWV*2.5 or Max. overload voltage for 5 seconds
	$\Delta R \pm 0.2\%$ for high power rating		
Insulation Resistance	$>1000 \text{ M}\Omega$		MIL-STD-202F Method 302 Apply $100V_{DC}$ for 1 minute
Endurance	$\Delta R \pm 0.05\%$	$\Delta R \pm 0.2\%$	MIL-STD-202F Method 108A $70 \pm 2^\circ\text{C}$, Max. working voltage for 1000 hrs with 1.5 hrs "ON" and 0.5 hrs "OFF"
	$>7k\Omega \Delta R \pm 0.5\%$		
	$\Delta R \pm 0.5\%$ for high power rating		
Damp Heat with Load	$\Delta R \pm 0.05\%$	$\Delta R \pm 0.3\%$	MIL-STD-202F Method 103B $40 \pm 2^\circ\text{C}$, 90~95% R.H. Max. working voltage for 1000 hrs with 1.5 hrs "ON" and 0.5 hrs "OFF"
	$\Delta R \pm 0.5\%$ for high power rating		
Bending Strength	$\Delta R \pm 0.05\%$	$\Delta R \pm 0.2\%$	JIS-C-5201-1 6.1.4 Bending amplitude 3 mm for 10 seconds
Solderability	95% min. coverage		MIL-STD-202F Method 208H $245 \pm 5^\circ\text{C}$ for 3 seconds
Resistance to Soldering Heat	$\Delta R \pm 0.05\%$	$\Delta R \pm 0.2\%$	MIL-STD-202F Method 210E $260 \pm 5^\circ\text{C}$ for 10 seconds
Dielectric Withstand Voltage	By Type		MIL-STD-202F Method 301 Max. overload voltage for 1 minute
Thermal Shock	$\Delta R \pm 0.05\%$	$\Delta R \pm 0.25\%$	MIL-STD-202F Method 107G $-55^\circ\text{C} \sim 150^\circ\text{C}$, 100 cycles
Low Temperature Operation	$\Delta R \pm 0.05\%$	$\Delta R \pm 0.2\%$	JIS-C-5201-1 7.1 1 hour, -65°C , followed by 45 minutes of RCWV
	$\Delta R \pm 0.5\%$ for high power rating		

■ Storage Temperature: $25 \pm 3^\circ\text{C}$; Humidity $< 80\%RH$

Reflow

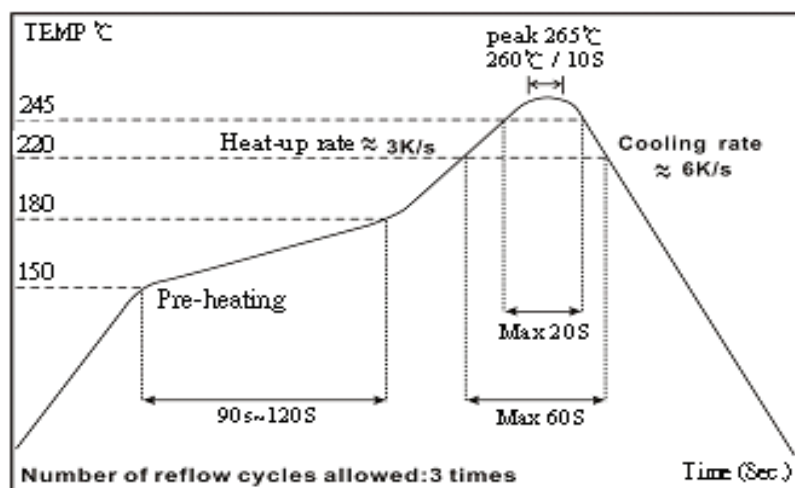

■ Marking

0603 3digit marking



3digit marking for Example: 14C=13K7Ω 13C=13K3Ω
68B=4K99Ω 68X=49.9Ω

Marking Table

Code	E96		Code	E96		Code	E96		Code	E96	
01	100		25	178		49	316		73	562	
02	102		26	182		50	324		74	576	
03	105		27	187		51	332		75	590	
04	107		28	191		52	340		76	604	
05	110		29	196		53	348		77	619	
06	113		30	200		54	357		78	634	
07	115		31	205		55	365		79	649	
08	118		32	210		56	374		80	665	
09	121		33	215		57	383		81	681	
10	124		34	221		58	392		82	698	
11	127		35	226		59	402		83	715	
12	130		36	232		60	412		84	732	
13	133		37	237		61	422		85	750	
14	137		38	243		62	432		86	768	
15	140		39	249		63	442		87	787	
16	143		40	255		64	453		88	806	
17	147		41	261		65	464		89	825	
18	150		42	267		66	475		90	845	
19	154		43	274		67	487		91	866	
20	158		44	280		68	499		92	887	
21	162		45	287		69	511		93	909	
22	165		46	294		70	523		94	931	
23	169		47	301		71	536		95	953	
24	174		48	309		72	549		96	976	
Code	A	B	C	D	E	F	G	H	X	Y	Z
Multiplier	10 ⁰	10 ¹	10 ²	10 ³	10 ⁴	10 ⁵	10 ⁶	10 ⁷	10 ⁻¹	10 ⁻²	10 ⁻³

0603 3digit marking for E24

Example: 101=100Ω 102=1KΩ

E24	10	11	12	13	15	16	18	20	22	24	27	30	33	36	39	43	47	51	56	62	68	75	82	91
-----	----	----	----	----	----	----	----	----	----	----	----	----	----	----	----	----	----	----	----	----	----	----	----	----

0805~2512 4digit marking

Example

Resistance	100Ω	2.2KΩ	10KΩ	49.9KΩ	100KΩ
marking	1000	2201	1002	4992	1003

■ Packaging

Packing Quantity & Reel Specifications

Unit :mm

Type	ØA	ØB	ØC	W	T	Paper Tape (EA)	Emboss Plastic Tape (EA)
AR01	178.0±1.0	60.0±1.0	13.5±0.7	9.5±1.0	11.5±1.0	10,000	-
AR02	178.0±1.0	60.0±1.0	13.5±0.7	9.5±1.0	11.5±1.0	10,000	-
AR03	178.0±1.0	60.0±1.0	13.5±0.7	9.5±1.0	11.5±1.0	5,000	-
AR05	178.0±1.0	60.0±1.0	13.5±0.7	9.5±1.0	11.5±1.0	5,000	-
AR06	178.0±1.0	60.0±1.0	13.5±0.7	9.5±1.0	11.5±1.0	5,000	-
AR13	178.0±1.0	60.0±1.0	13.5±0.7	9.5±1.0	11.5±1.0	5,000	-
AR10	178.0±1.0	60.0±1.0	13.5±0.7	13.5±1.0	15.5±1.0	-	4,000
AR12	178.0±1.0	60.0±1.0	13.5±0.7	13.5±1.0	15.5±1.0	-	4,000

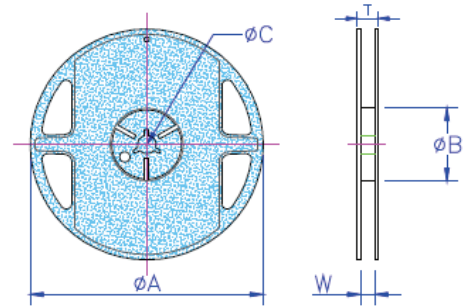

Paper Tape Specifications

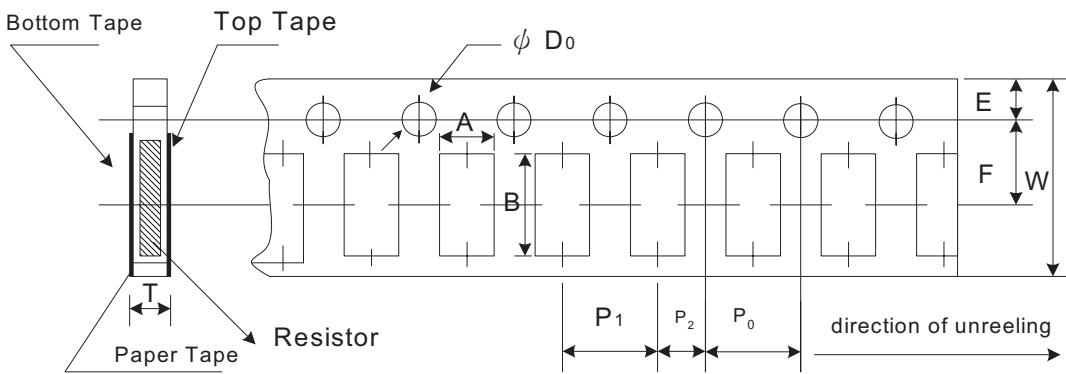

Unit: mm

Type	A	B	W	E	F	P ₀	P ₁	P ₂	ΦD ₀	T
AR01	0.40±0.05	0.70±0.05	8.00±0.10	1.75±0.05	3.5±0.05	4.00±0.10	2.00±0.05	2.00±0.05	1.55±0.03	0.42±0.02
AR02	0.70±0.05	1.16±0.05	8.00±0.10	1.75±0.05	3.5±0.05	4.00±0.10	2.00±0.05	2.00±0.05	1.55±0.05	0.40±0.03
AR03	1.10±0.05	1.90±0.05	8.00±0.10	1.75±0.05	3.5±0.05	4.00±0.10	4.00±0.10	2.00±0.05	1.55±0.05	0.60±0.03
AR05	1.60±0.05	2.37±0.05	8.00±0.10	1.75±0.05	3.5±0.05	4.00±0.10	4.00±0.10	2.00±0.05	1.55±0.05	0.75±0.05
AR06	2.00±0.05	3.55±0.05	8.00±0.10	1.75±0.05	3.5±0.05	4.00±0.10	4.00±0.10	2.00±0.05	1.55±0.05	0.75±0.05
AR13	2.75±0.05	3.40±0.05	8.00±0.10	1.75±0.05	3.5±0.05	4.00±0.05	4.00±0.10	2.00±0.05	1.60±0.10	0.75±0.05

- Peel force of top cover tape
- The peel speed shall be about 300mm/min±5%
- The peel force of top cover tape shall be between 8g to 40g

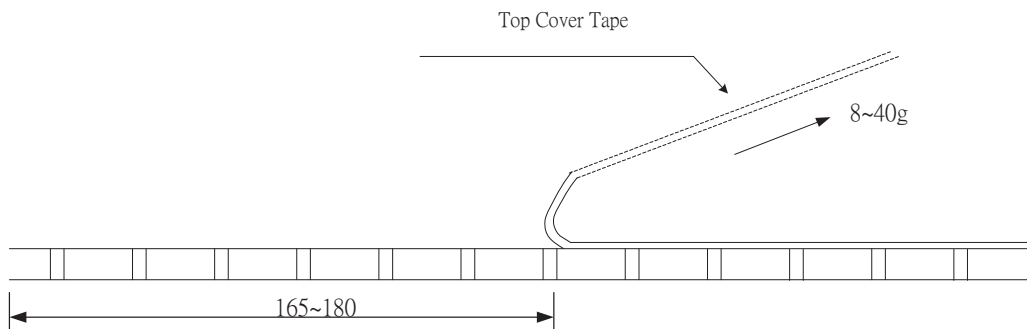

Emboss Plastic Tape Specifications

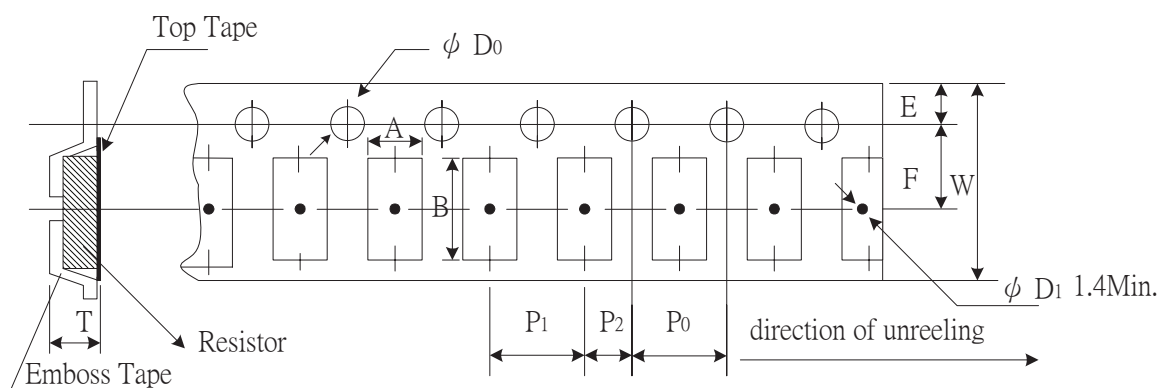

Unit: mm

Type	A	B	W	E	F	P ₀	P ₁	P ₂	ØD ₀	T
AR10	2.85±0.10	5.45±0.10	12.0±0.10	1.75±0.10	5.5±0.05	4.00±0.05	4.00±0.10	2.00±0.05	1.50±0.10	1.00±0.20
AR12	3.40±0.10	6.65±0.10	12.0±0.10	1.75±0.10	5.5±0.05	4.00±0.05	4.00±0.10	2.00±0.05	1.50±0.10	1.00±0.20

- Peel force of top cover tape
- The peel speed shall be about 300mm/min±5%
- The peel force of top cover tape shall be between 20g to 80g

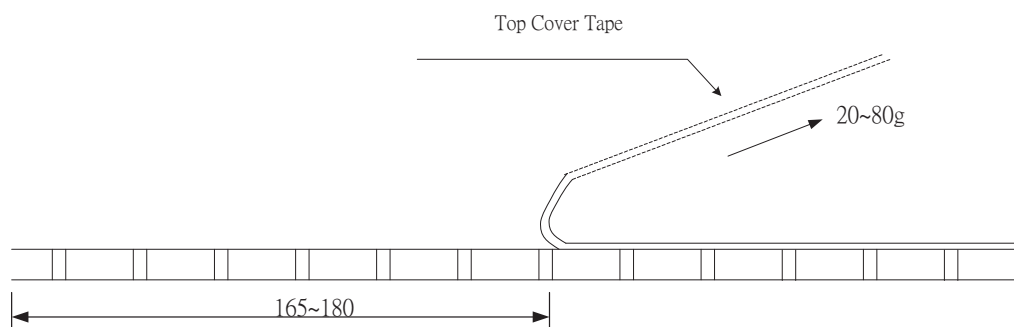

Recommend Land Pattern

Unit: mm

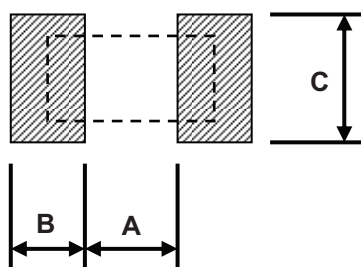

Type	A	B	C
AR01	0.25	0.30	0.40±0.2
AR02	0.50	0.50	0.60±0.2
AR03	0.80	1.00	0.90±0.2
AR05	1.00	1.00	1.35±0.2
AR06	2.00	1.15	1.70±0.2
AR13	2.00	1.15	2.50±0.2
AR10	3.60	1.40	2.50±0.2
AR12	4.90	1.60	3.10±0.2