

ISA-PLAN®- Precision Resistor Type PBV

Spec Sheet R361-1/2 July 97

Technical Data	
Resistance range	0.5 mOhm - 1 Ohm
Tolerances	0.5 %, 1 %, 5 %
Temperature coefficient (R > 10 mOhm)	< 30 ppm/K (20 °C to 60 °C)
Applicable temperature range	-55 °C to +125 °C
Load capacity	3 W / 10 W with heatsink provided
Thermal resistance to aluminum base plate	Rth < 3 K/W
Thermal resistance to ambient	Rth < 15 K/W
Dielectric withstanding voltage	500 V AC
Inductance (R = 50 mOhm)	< 5 nH
Stability (nominal load at 70 °C)	deviation < 0.5 % after 2,000 h

- Remarks:
- Standard resistance values according to E12 with the additional values of 2 and 5
 - Minimum quantity of other values on request
 - Tolerance 0.5% for values from 4,7 mOhm

The four-terminal resistor type **PBV** derived from type PBH is especially designed for the low impedance range, in order to obtain lowest temperature coefficient values, and in order to guarantee the independence of the resistance value from the soldering quality. The use of the precision resistance material **MANGANIN** combined with a highly temperature resistant and humidity insusceptible Duroplast cover as well as optimization of layout and lines result in a high longterm stability, low temperature coefficient and low inductance.

The shape is compatible with the latest power transistors. The resistor is mounted through a center bore or

spring clamp to a heatsink, whereby the large area of the base plate will provide excellent heat transfer. The low thermal resistance between resistor foil and aluminum base plate warrants for a low temperature rise at nominal load in this configuration and permits transient overloading up to one magnitude.

The resistor is ideally suited for applications in power electronic and control technique, as most applications at inductive loading will require operation with switched power regulating units.

Short connection distances and small dimensions at high load capacity and low inductance are a prerequisite to obtain high switching frequencies.

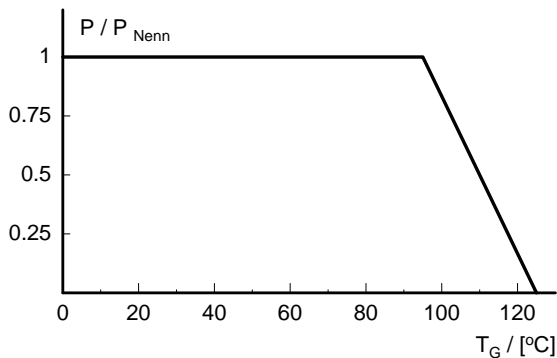

power derating curve

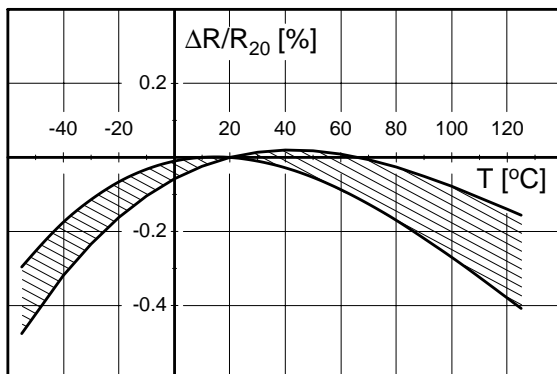

Temperature dependence of the electrical resistance of ISA-PLAN Resistors

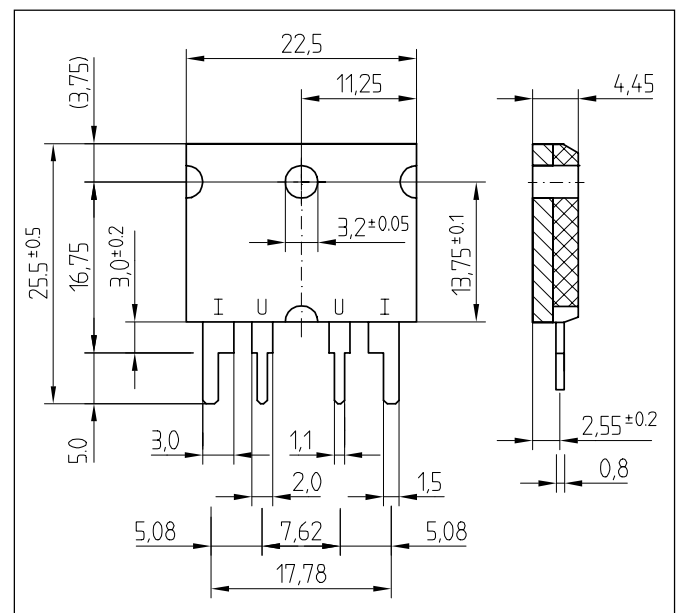

dimensions (mm)

ordering example: PBV - R001 - F1 - 1

type	resistance value	terminal	tolerance
PBV	1 mOhm	F1	1 %

(Technical modifications reserved)

ISABELLENHÜTTE Heusler GmbH KG

35664 Dillenburg P.O.Box 1453 Phone ++49 27 71/9 34-0 Telefax ++49 27 71/2 30 30



ISA-PLAN® - Präzisionswiderstände / Precision resistors

TECHNISCHE DATEN / TECHNICAL DATA		
Widerstandswerte	Resistance values	0,5 mOhm - 1 Ohm
Toleranz	Tolerance	0.5 % , 1 % , 5 %
Temperaturkoeffizient(MANGANIN®)	Temperature coefficient (tcr)	< 30 ppm/K (20 °C to 60 °C); > R010
Temperaturbereich	Applicable temperature range	-55 °C to +125 °C
Belastbarkeit	Load capacity	3 W 10 W Kühlkörpermontage / with heatsink provided
Wärmewiderstand zur Umgebung(R_{th})	Thermal resistance to ambient(R_{th})	< 15 K/W
Innerer Wärmewiderstand zum Aluminium Substrat (R_{thi})	Thermal resistance to aluminium substrat (R_{thi})	< 3 K/W < 6 K/W for R < 2 mOhm
Isolationsspannung	Dielectric withstanding voltage	500 V AC
Induktivität (100 mOhm)	Inductance (100 mOhm)	< 10 nH
Stabilität (Nennlast) Abweichung T_K = Kontaktstellentemperatur Stability (nominal load) deviation T_K = Terminal temperature		< 0.5 % nach/after 2000 h (T_K = 70 °C)

MERKMALE / FEATURES

- 3 W Dauerleistung / 10 W bei Kühlkörpermontage
- 3 W permanent power / 10 W with heatsink provided
- Vierleiteranschluss des Widerstands
- Four terminal connection of the resistor
- Sehr hohe Pulsbelastbarkeit 2 Joule für 10 ms
- High pulse power rating 2 Joule for 10 ms
- Sehr gute Langzeitstabilität
- Excellent long term stability



APPLIKATIONEN / APPLICATION

- Leistungsmodul
- Power modules
- Frequenzumrichter
- frequency converters
- Schaltnetzteile
- Switch mode power supplies

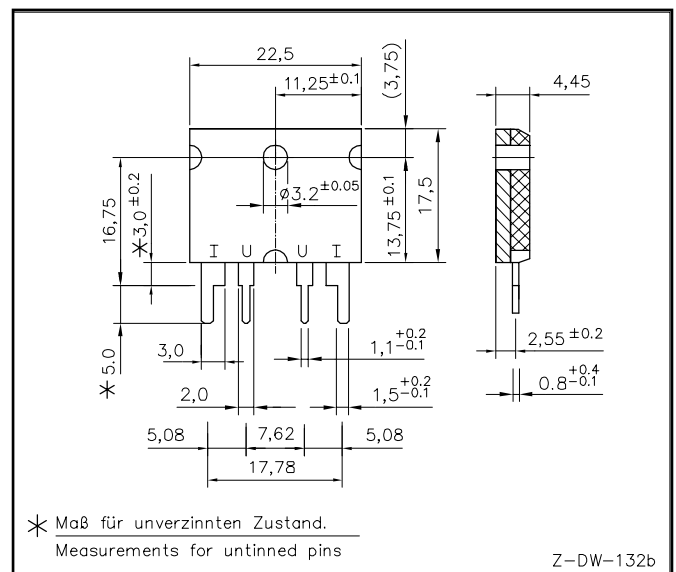

Abmessungen (mm) / dimensions (mm)



TK, Lastminderung und Langzeitstabilität / TCR, power derating and long term stability

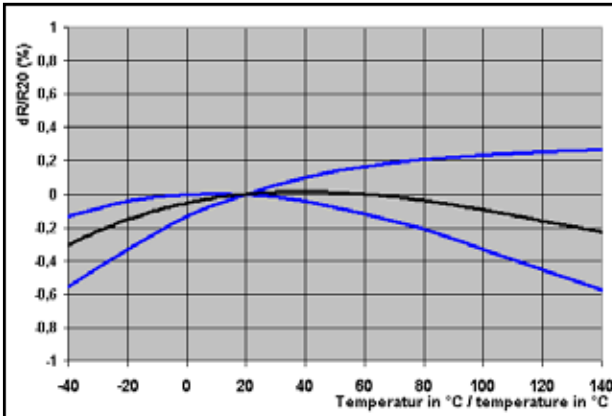

Temperaturabhängigkeit des elektrischen Widerstandes von MANGANIN®-Widerständen
Temperature dependence of the electrical resistance of MANGANIN®-resistors

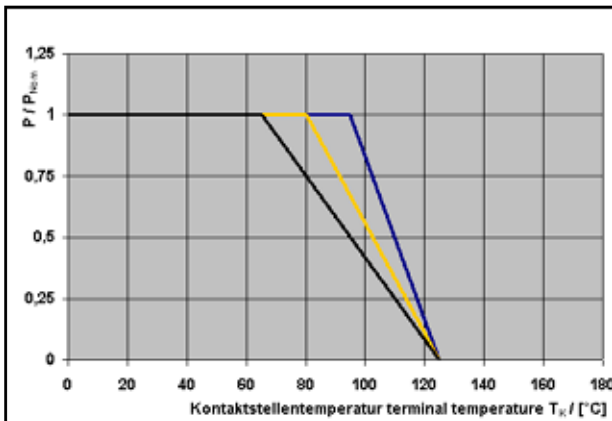

Lastminderungskurve für PBV montiert auf Kühlkörper
Power derating curve for heatsink mounted PBV

- montiert auf Kühlkörper / heatsink mounted $R > 2\text{m}\Omega$; $P = 10\text{W}$
- ohne Kühlkörper / without heatsink ($P = 3\text{ Watt}$)
- montiert auf Kühlkörper/heatsink mounted $R < 2\text{m}\Omega$; $P = 10\text{W}$

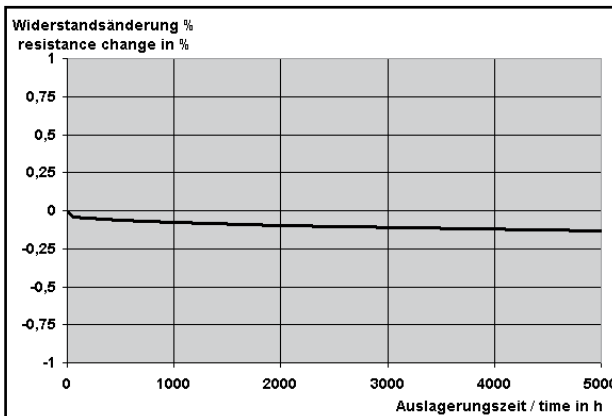

Langzeitstabilität von Manganin® Widerständen bei 140 °C
Long term stability of Manganin® - resistors at 140 °C

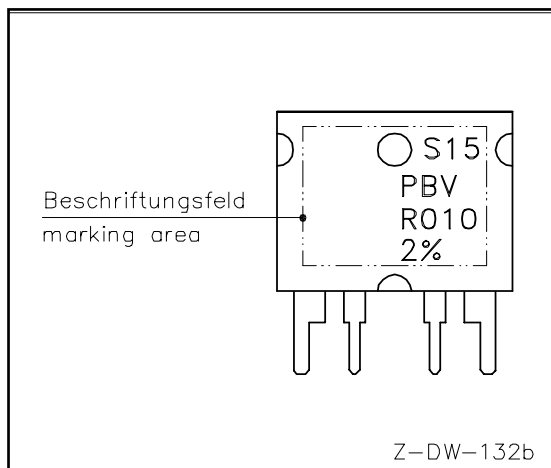

Beschriftung / Marking

Montagehinweis

Maximal zulässiges Anzugsmoment für Schrauben M3: 1 Nm

Assembly instruction

Maximum torque for M3 screws: 1 Nm

Lötprofil Vorschlag / Recommended solder profile			
Wellenlöten			
Wave soldering			
Temperatur	260 °C	255 °C	217 °C
Zeit (s)	peak	40	90
<p>RoHS 2002/95/EG konform seit 01.01.2005 Ausführliche Informationen erhalten Sie auf unserer Homepage: www.isabellenuette.de</p> <p>RoHS 2002/95/EC compliance since 01.01.2005 For more information please visit our website: www.isabellenuette.de</p>			

VERPACKUNGSINFORMATIONEN PACKAGING INFORMATION	
Stangenmagazin/Tube	
Anzahl Bauteile/Parts per tube	25 Stück/pieces

BESTELLBEZEICHNUNG / ORDERING CODE			
PBV-R0005-F1-0.5			
Typ	Widerstandswert	Anschlüsse	Toleranz
Type	Resistance value	terminal	Tolerance
PBV	500 µOhm	F1	0.5 %

Gewährleistung

Alle Angaben über Eignung, Verarbeitung und Anwendung unserer Produkte, technische Beratung und sonstige Angaben erfolgen nach bestem Wissen, befreien den Käufer jedoch nicht von eigenen Prüfungen und Versuchen.

Warranty

All information regarding the suitability, workability and applicability of our products, all technical advice and other information are provided to the best of our knowledge and belief, but shall not discharge the buyer from his own examinations and tests.

Grenzkurve für maximale Pulsenergie bzw. Pulsleistung für Dauerbetrieb
Diagram of pulse energie. Maximum puls energy resp. pulse power for continous operation

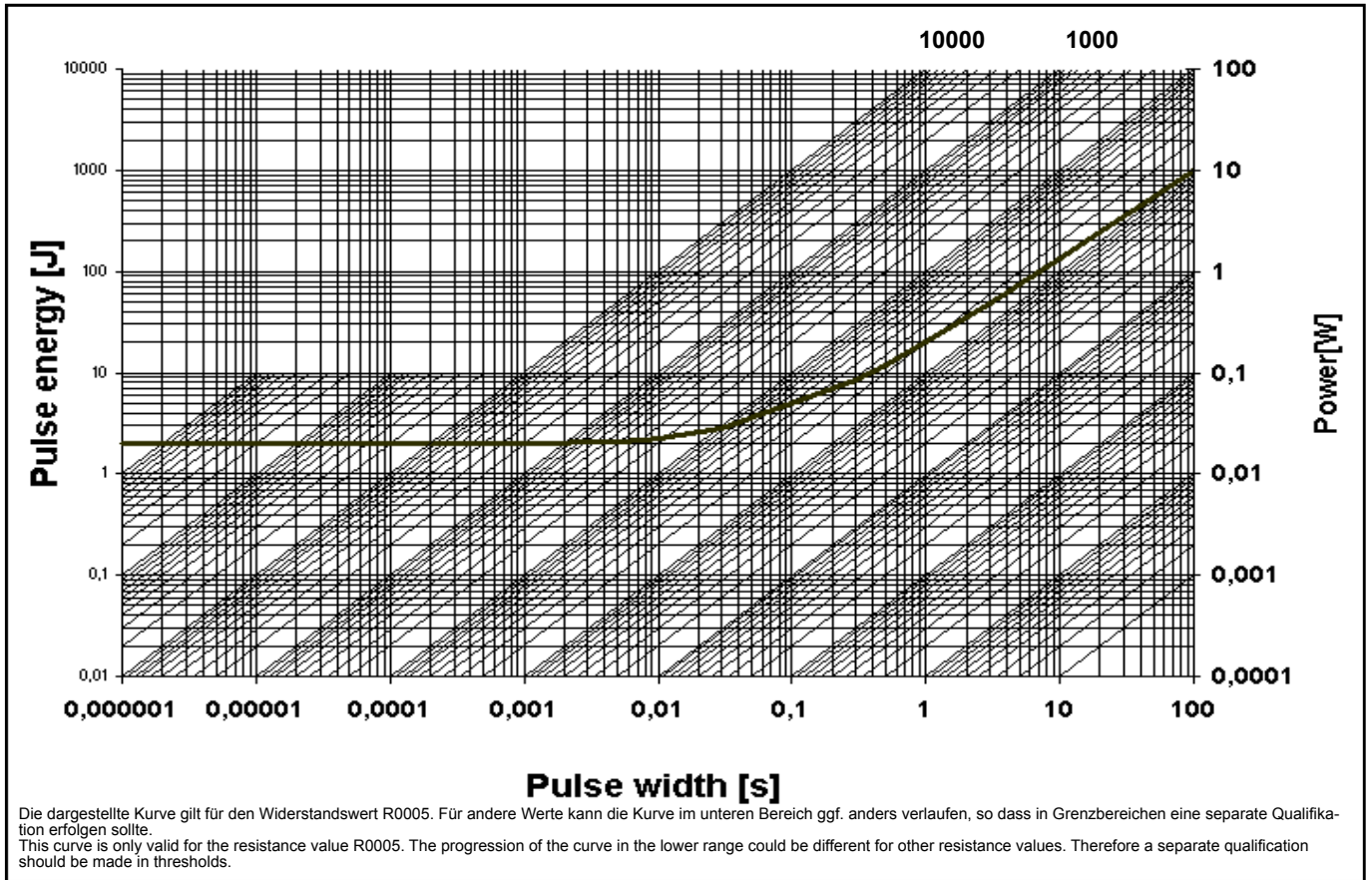

Spezifikation/Spesifikation			
Parameters	Test Conditions	Specification	Typical data
Maximum Temperature for full power operation (R > 2 mOhm)	70/90 °C	65/95 °C	95 °C
Working Temperature	-55 to 125 °C	-55 to 125 °C	-55 to 125 °C
Thermal Shock	MIL-STD-202 method 107-B1	0.1 %	0.1 %
Overload	MIL-R-26E (5 times rated power, 5 sec)	0.2 %	0.1 %
Solderability	MIL-STD-202 method 208	> 95 % coverage	> 95 % coverage
Resistance to Solvents	MIL-STD-202 method 215, 2.1a, 2.1d	no damage	no damage
Low Temperature Storage and Operation	MIL-STD-26E	0.1 %	0.03 %
Terminal Strength	MIL-STD-202 method 211	50N, 0.02 %	0.02 %
Resistance to Soldering Heat	MIL-STD-202 method 210	0.1 %	0.02 %
Moisture Resistance	MIL-STD-202 method 106	0.1 %	0.01 %
Shock	MIL-STD-202 method 213-A	0.2 %	0.1 %
Vibration, High Frequency	MIL-STD-202 method 204-B	0.2 %	0.05 %
Life	MIL-STD-26E	0.2 %	0.1 %
Storage Life at Elevated Temperature	MIL-STD-202 method 108-F	0.3 %	0.2 %
High Temperature Exposure	140 °C, 2000 h	0.2%	0.2 %
Current Noise	MIL-STD-202 method 308	0.01 %	0.001 %
Voltage Coefficient (%/V)	MIL-STD-202 method 309	linearity error less than 120dB	
Resistance Temperature Characteristic	MIL-STD-202 method 304 (20-60°C)	< 30 ppm/K	< 30 ppm/K
Thermal EMF	0 - 100 °C	2 µV/K max.	2 µV/K
Frequency Characteristic	inductivity	< 10 nH	< 10 nH