

Electronic housing - UM108-PROFIL 100CM - 2907525

Please be informed that the data shown in this PDF Document is generated from our Online Catalog. Please find the complete data in the user's documentation. Our General Terms of Use for Downloads are valid (<http://download.phoenixcontact.com>)



Drawn section panel mounting base, with a constructional width of 108 mm and a fixed length of 100 cm

The illustration shows the variant UM 45-Profil CM

Product Features

- Lateral elements with potential ground contact available from the PCB to the DIN rail (EMC)
- Wide range of options for external conductor connection
- Fast assembly on standard NS 35 or NS 32 DIN rails
- Inexpensive as a result of reducing the number of separate housing parts
- Flexible size and shape
- High degree of mechanical stability by screwing the lateral elements to the profile
- The modules can be marked with Phoenix Contact marking material using the marking grooves in the press-drawn section

Key commercial data

package_quantity	1
GTIN	4017918336653

Technical data

General

Housing type	Panel mounting base
Housing material	PVC
Color	green

Ambient conditions

Ambient temperature (operation)	-15 °C ... 50 °C
--	------------------

Dimensions

Width	1000 mm
--------------	---------

Technical data

Inflammability class according to UL 94	V0
--	----

classifications

eCl@ss

eCl@ss 4.0	27180401
-------------------	----------

Electronic housing - UM108-PROFIL 100CM - 2907525

classifications

eCl@ss

eCl@ss 4.1	27180401
eCl@ss 5.0	27180506
eCl@ss 5.1	27180506
eCl@ss 6.0	27180802
eCl@ss 7.0	27182701
eCl@ss 8.0	27182701

ETIM

ETIM 2.0	EC001031
ETIM 3.0	EC001031
ETIM 4.0	EC001031
ETIM 5.0	EC000721

UNSPSC

UNSPSC 6.01	31261501
UNSPSC 7.0901	31261501
UNSPSC 11	31261501
UNSPSC 12.01	31261501
UNSPSC 13.2	31261501

accessories

Mounting material

UM108-FE - 2959463



UMK-BF - 2976077



Electronic housing - UM108-PROFIL 100CM - 2907525

accessories

UM108-FE - 2959463



UMK-BF - 2976077



Panel mounting base side part

UM108-SEPEF/L - 2906490



UM108-SE - 2959476



UM108-SEFE/R-A60 - 2959706



Electronic housing - UM108-PROFIL 100CM - 2907525

accessories

UM108-SEFE/R-A73 - 2959719



UM108 N-SEFE/R-A73 - 2709354



UM108-SEFE/L-A60 - 2959722



UM108-SEPEF/L-A60 - 2906500



UM108-SEFE/L-A73 - 2959735



UM108-SEPEF/L-A73 - 2906513



Electronic housing - UM108-PROFIL 100CM - 2907525

accessories

UM108 N-SEFE/L-A73 - 2709367



UM108 N-SEPEF/L-A73 - 2709370



UM108-SE-A60 - 2959748



UM108-SE-A73 - 2959751



UM108 N-SE-A73 - 2709383



Component housing cover

Electronic housing - UM108-PROFIL 100CM - 2907525

accessories

UM-A/U N 73 CM - 2706852

Component housing lower part

UM108-LG 10 - 2959780



accessories

UM108-A/U CM - 2854898

Drawings

Electronic housing - UM108-PROFIL 100CM - 2907525

Dimensioned drawing

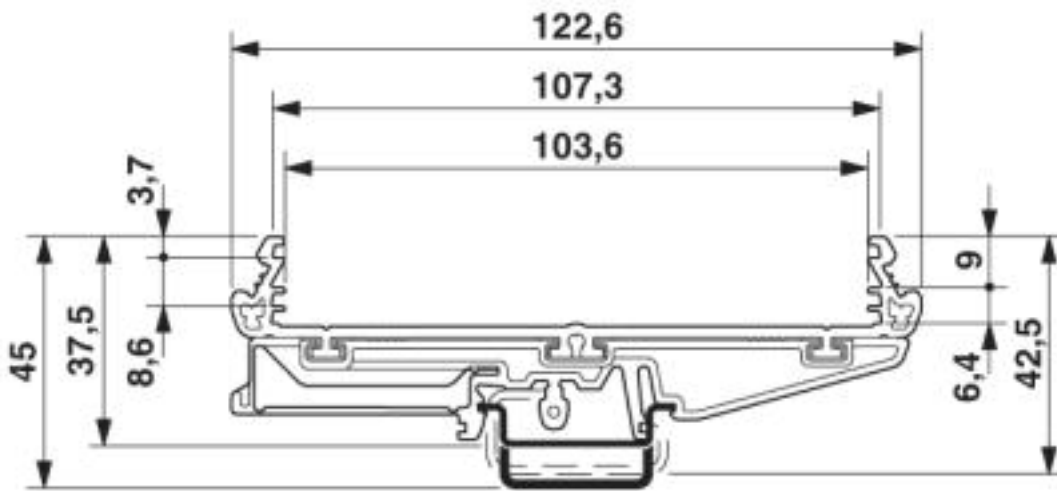

© Phoenix Contact 2013 - all rights reserved
<http://www.phoenixcontact.com>